

# YUKON SERIES SPLIT HEAT PUMPS

MSH-60IB/3  
MSH-100IB-3/9  
MSH-160IB-3/9

MSH-60EB  
MSH-80EB  
MSH-100EB

MSH-120EB-3  
MSH-140EB-3  
MSH-160EB-3

**S-THERM**

 **SINCLAIR**  
HEAT PUMPS

**IMPORTANT NOTE:**

Read this manual carefully before installing or operating your new heat pump.  
Make sure to save this manual for future reference.

<b>Unit Capacities .....</b>	<b>6</b>
<b>External Appearance .....</b>	<b>7</b>
<b>Layout of Functional Components.....</b>	<b>9</b>
<b>Piping Diagrams .....</b>	<b>14</b>
<b>Refrigerant Flow Diagrams .....</b>	<b>16</b>
<b>Stop Operation.....</b>	<b>19</b>
<b>Standby Control .....</b>	<b>19</b>
<b>Startup Control .....</b>	<b>20</b>
<b>Normal Operation Control.....</b>	<b>23</b>
<b>Protection Control.....</b>	<b>24</b>
<b>Special Control .....</b>	<b>27</b>
<b>Role of Temperature Sensors in Control Functions .....</b>	<b>30</b>
<b>Electric Control Box Layout.....</b>	<b>33</b>
<b>PCBs.....</b>	<b>36</b>
<b>Error Code Table.....</b>	<b>50</b>
<b>Troubleshooting.....</b>	<b>52</b>
<b>Appendix to Part 4 .....</b>	<b>110</b>
<b>S-Therm Yukon System .....</b>	<b>114</b>
<b>Unit Capacities .....</b>	<b>116</b>
<b>System Design and Unit Selection .....</b>	<b>117</b>
<b>Typical Applications .....</b>	<b>120</b>
<b>Specifications .....</b>	<b>129</b>
<b>Dimensions and Center of Gravity.....</b>	<b>135</b>
<b>Piping Diagrams .....</b>	<b>138</b>

Wiring Diagrams .....	140
Capacity Tables .....	144
Operating Limits.....	160
Hydronic Performance .....	161
Sound Levels .....	162
Accessories .....	167
Preface to Part 7.....	169
Installation.....	170
Refrigerant Pipework .....	178
Water Pipework .....	191
Electrical Wiring .....	194
DIP Switch Settings .....	197
Internal Circulation Pump .....	197
User Interface Field Settings.....	198
Operation parameter .....	218
Network Configuration Guidelines .....	219
USB Function Guidelines .....	223
Climate Related Curves .....	225
Error Code Table.....	228

# Part 1

## General Information

<b>1 Unit Capacities .....</b>	<b>6</b>
<b>2 External Appearance .....</b>	<b>8</b>

# S-Therm Yukon split series

## 1 Unit Capacities

### 1.1 Outdoor Unit Capacities

*Table 1-1.1: Capacity range*

Capacity	4kW	6kW	8kW	10kW	12kW	14kW	16kW
S-Therm Yukon 1phase	/	MSH-60EB	MSH-80EB	MSH-100EB	MSH-120EB	MSH-140EB	MSH-160EB
S-Therm Yukon 3phase	/	/	/	/	MSH-120EB-3	MSH-140EB-3	MSH-160EB-3

### 1.2 Hydronic Box Model



*Table 1-1.2: Model*

Model <sup>1</sup>	MSH-60IB MSH-60IB/3	MSH-100IB MSH-100IB/3 MSH-100IB-3/9	MSH-160IB MSH-160IB/3 MSH-160-3/9
Compatible OU model	MSH-60EB	MSH-80EB MSH-100EB	MSH-120EB MSH-140EB MSH-160EB MSH-120EB-3 MSH-140EB-3 MSH-160EB-3

## 2 External Appearance

### 2.1 Outdoor Unit Appearance

Table 1-2.1: Outdoor unit appearance

<p><b>MSH-60EB</b> <b>MSH-80EB</b> <b>MSH-100EB</b></p>	<p><b>MSH-120EB; MSH-140EB; MSH-160EB</b> <b>MSH-120EB-3; MSH-140EB-3; MSH-160EB-3</b></p>
	

### 2.2 Hydronic Box Appearance

Table 1-2.2: Hydronic box appearance

<p><b>MSH-60IB</b> <b>MSH-60IB/3</b></p>	<p><b>MSH-100IB-3/9</b> <b>MSH-100IB/3</b> <b>MSH-100IB</b></p>	<p><b>MSH-160IB</b> <b>MSH-160IB-3/9</b> <b>MSH-160IB/3</b></p>
		

# Part 2

# Component Layout and Refrigerant Circuits

1	Layout of Functional Components .....	9
2	Piping Diagrams.....	15
3	Refrigerant Flow Diagrams.....	16

### 3 Layout of Functional Components

#### 3.1 Outdoor Unit Layout

##### MSH-60EB

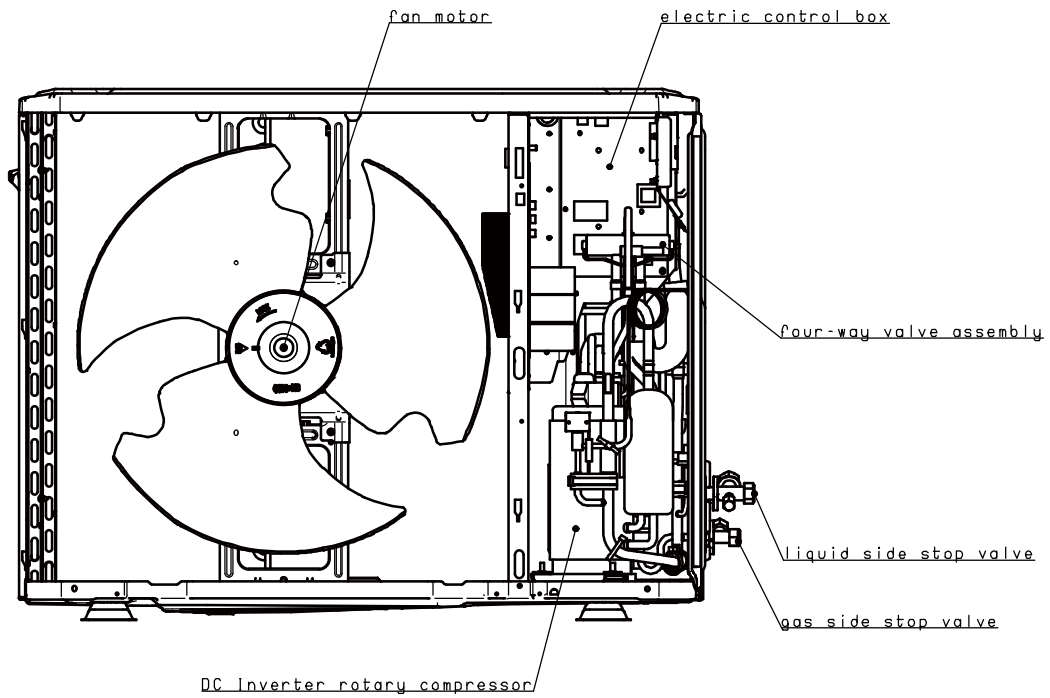
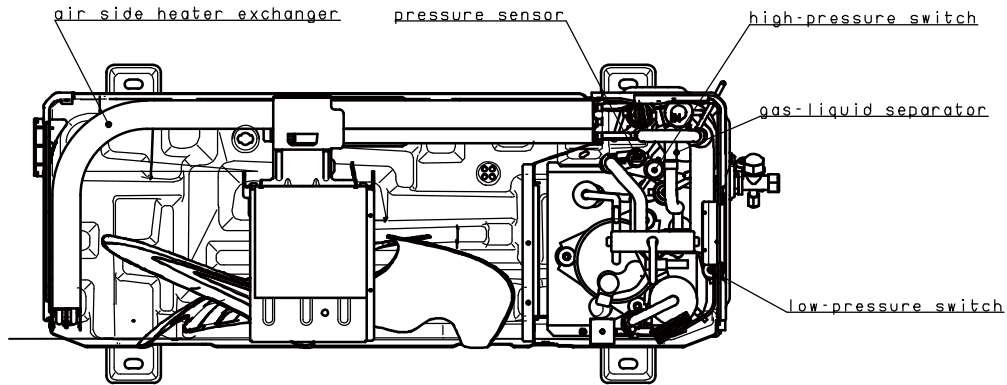

S-Therm Yukon split series  
MSH-80EB; MSH-100EB

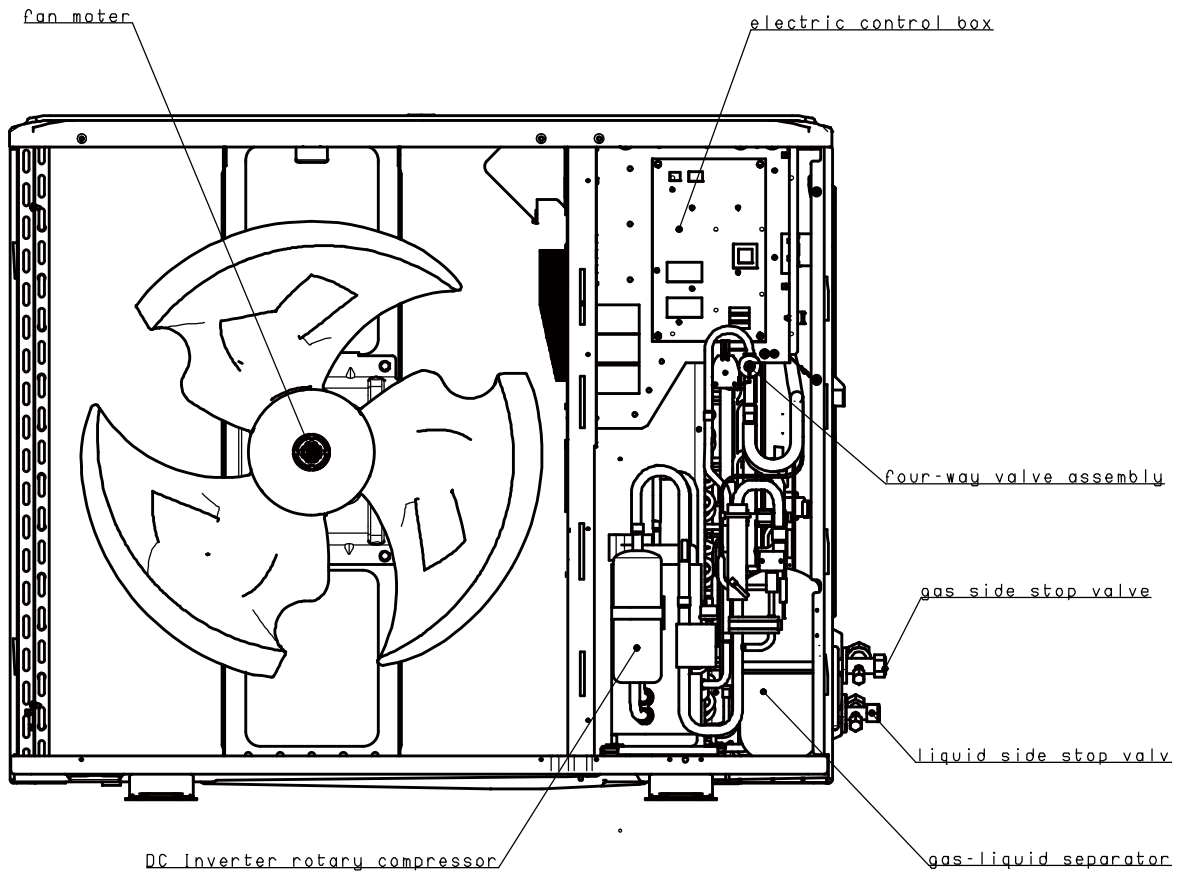
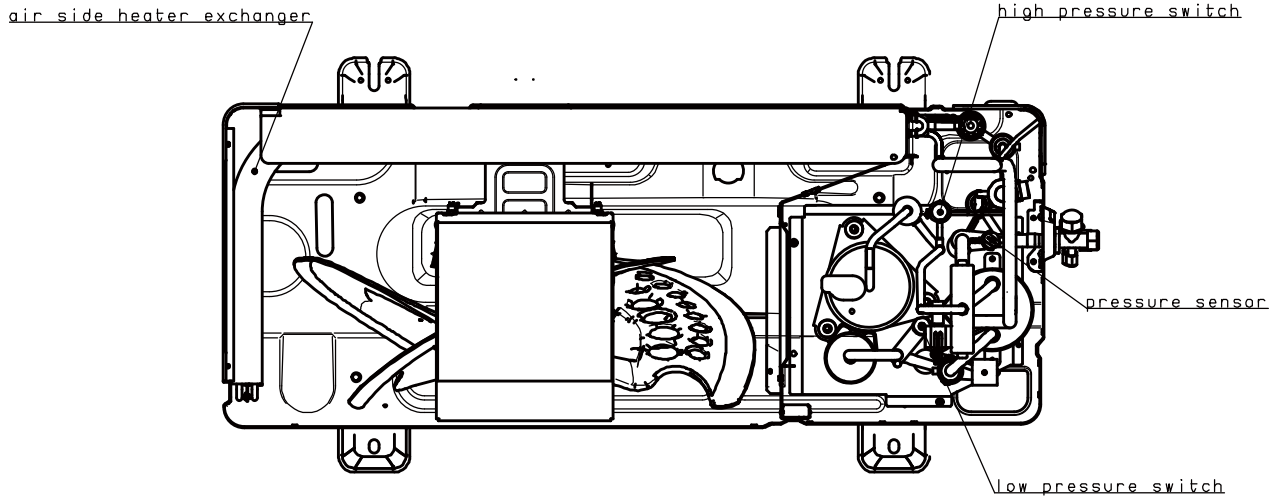

MSH-120EB; MSH-140EB; MSH-160EB

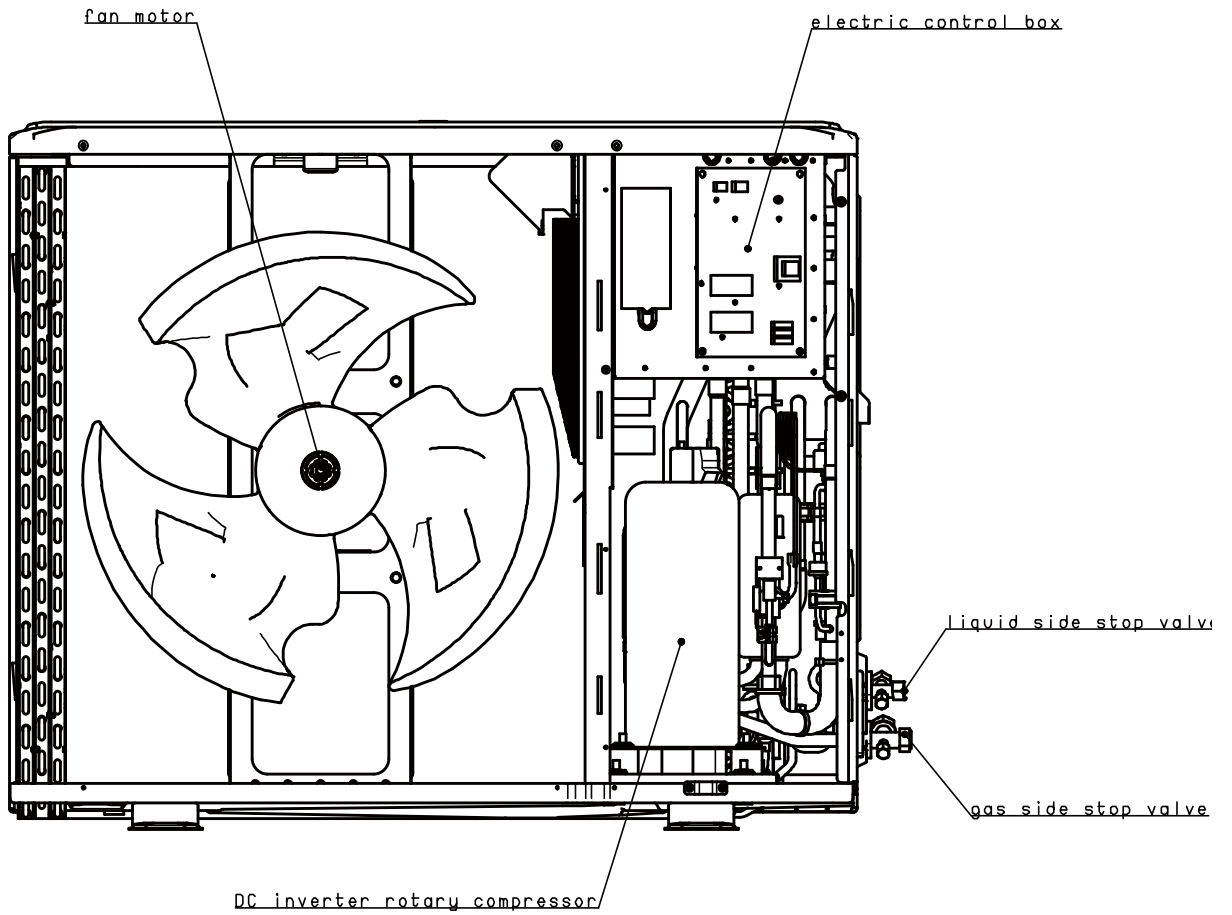
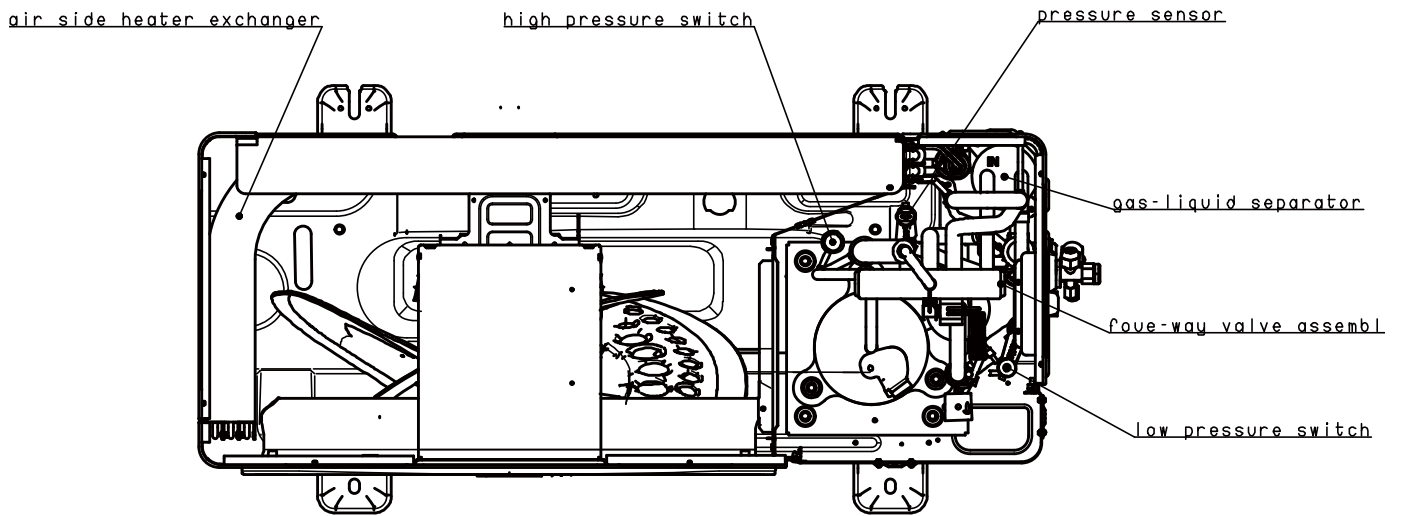

**S-Therm Yukon split series**  
MSH-120EB-3; MSH-140EB-3; MSH-160EB-3

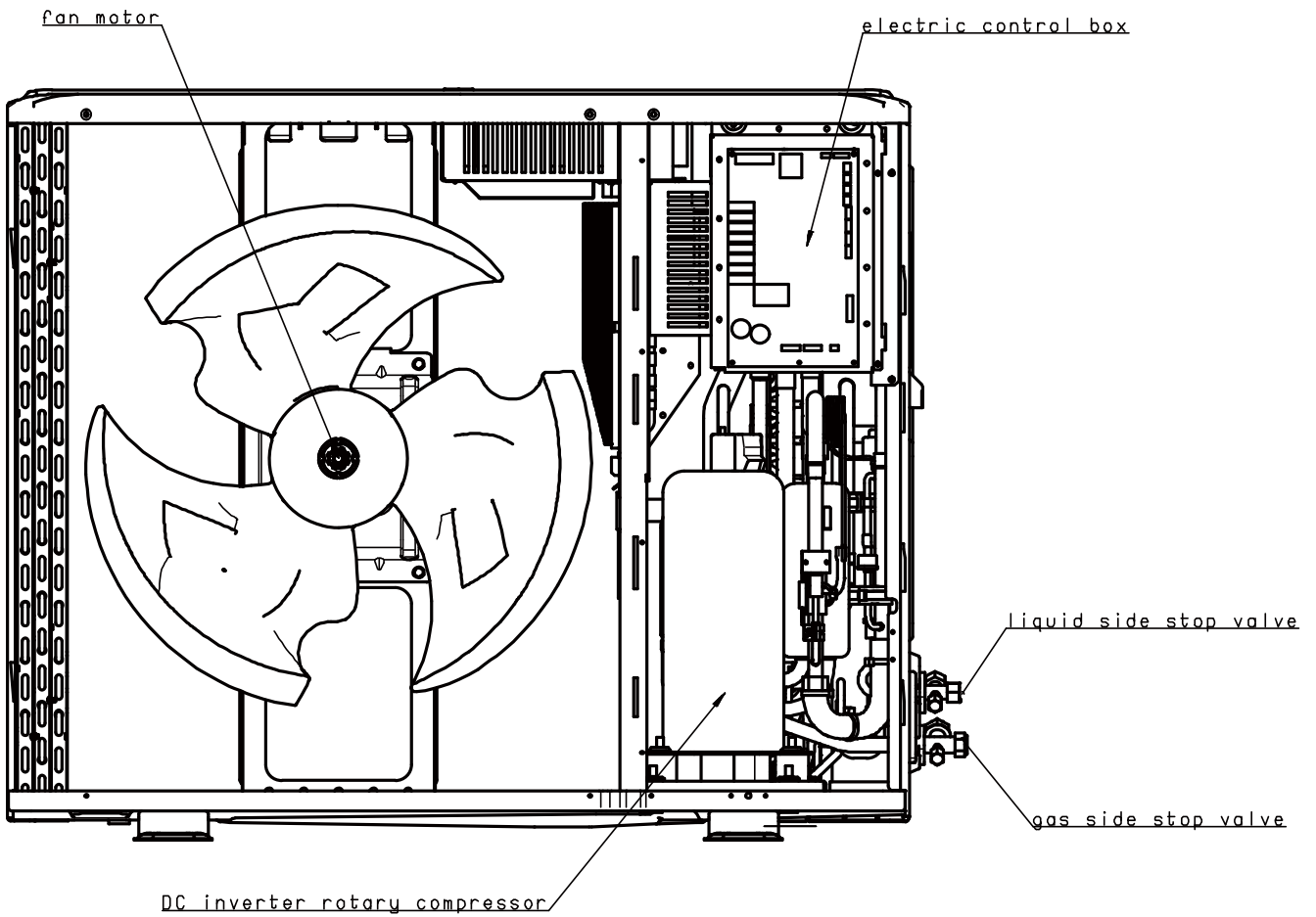
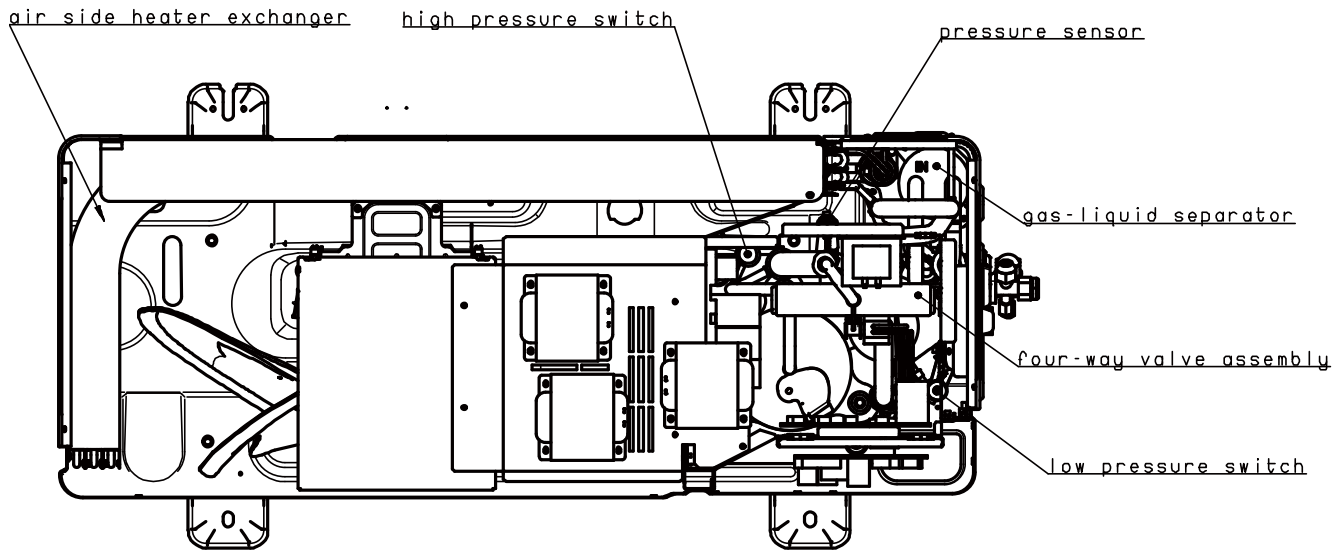

**3.2 Hydronic Box Layout**

*MSH-60IB; MSH-100IB; MSH-160IB; MSH-60IB/3; MSH-100IB/3; MSH-100-3/9*

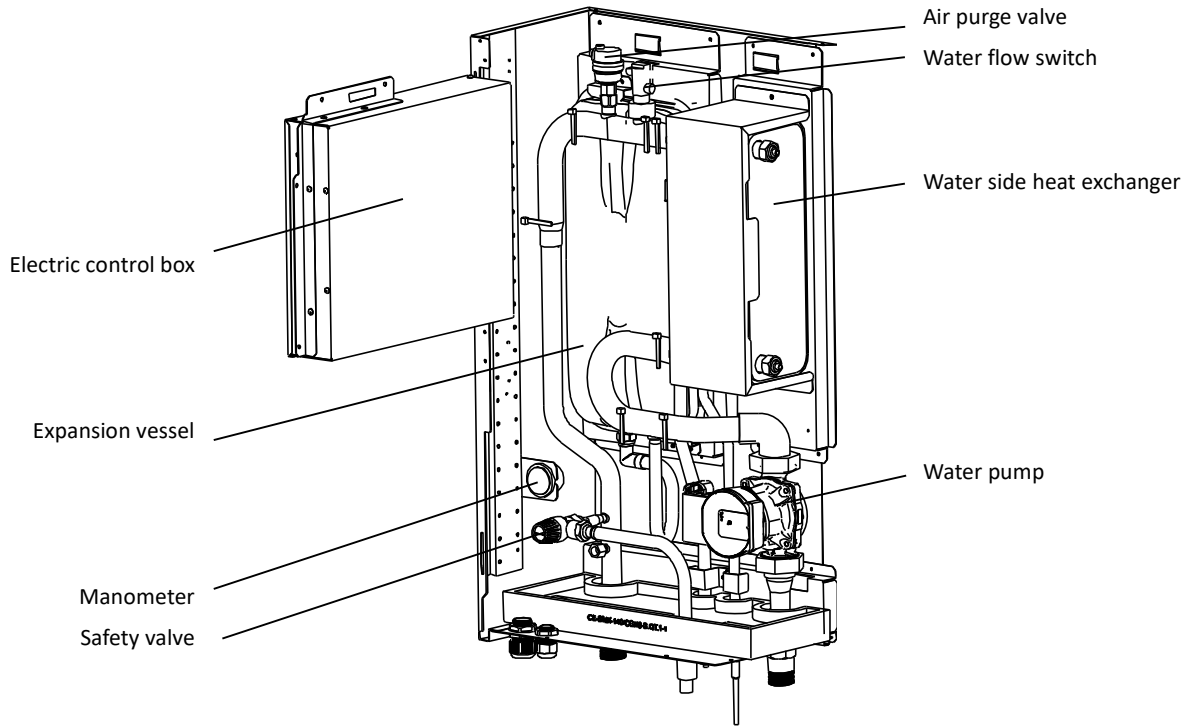

## 4 Piping Diagrams

### 4.1 Outdoor Unit Piping

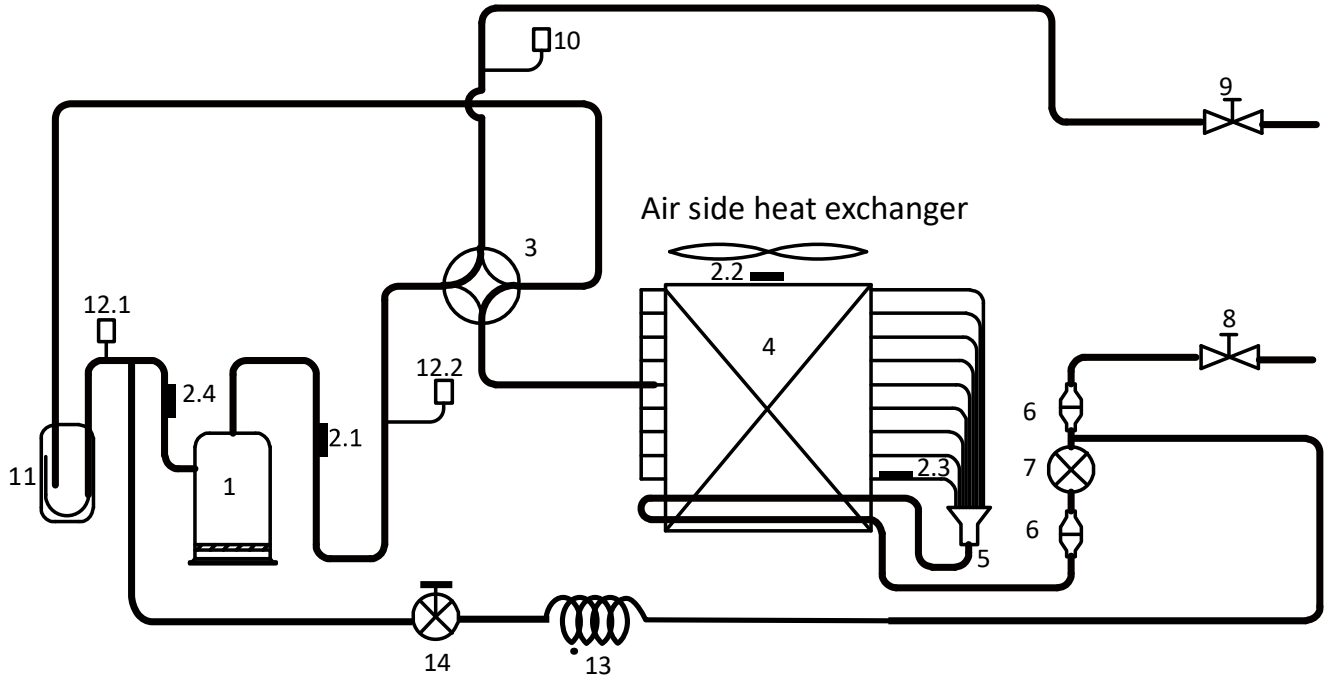

Legend			
1	Compressor	7	Electronic expansion valve
2.1	Discharge pipe temperature sensor	8	Stop valve (liquid side)
2.2	Outdoor ambient temperature sensor	9	Stop valve (gas side)
2.3	Air side heat exchanger refrigerant outlet temperature sensor	10	Pressure sensor
2.4	Suction pipe temperature sensor	11	Separator
3	4-way valve	12.1	Low pressure switch
4	Air side heat exchanger	12.2	High pressure switch
5	Distributor	13	Capillary
6	Filter	14	Solenoid valve

#### Key components:

**1. Electronic expansion valve (EXV):**

Controls refrigerant flow and reduces refrigerant pressure.

**2. Four-way valve:**

Controls refrigerant flow direction. Closed in cooling mode and open in heating mode. When closed, the air side heat exchanger functions as a condenser and water side heat exchanger functions as an evaporator; when open, the air side heat exchanger functions as an evaporator and water side heat exchanger function as a condenser.

**3. High and low pressure switches:**

Regulate refrigerant system pressure. When refrigerant system pressure rises above the upper limit or falls below the lower limit, the high or low pressure switches turn off, stopping the compressor.

**4. Separator:**

Separates liquid refrigerant from gas refrigerant to protect compressor from liquid hammering.

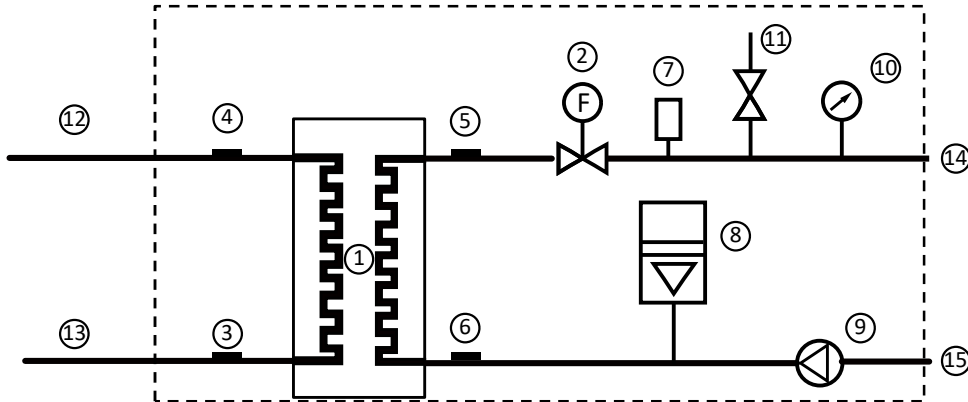
**4.2 Hydronic box Piping**
*Figure 2-2.2: Hydronic box piping diagram*

Legend			
1	Water side heat exchanger	9	Water pump
2	Water flow switch	10	Manometer
3	Refrigerant liquid line temperature sensor	11	Safety valve
4	Refrigerant gas line temperature sensor	12	Refrigerant gas side
5	Water outlet temperature sensor	13	Refrigerant liquid side
6	Water inlet temperature sensor	14	Water outlet
7	Air purge valve	15	Water inlet
8	Expansion vessel		

**Key components:**
**1. Air purge valve:**

Automatically removes air from the water circuit.

**2. Safety valve:**

Prevents excessive water pressure by opening at 43.5 psi (3 bar) and discharging water from the water circuit.

**3. Expansion vessel:**

Balances water system pressure. (Expansion vessel volume: 8L.)

**4. Water flow switch:**

Detects water flow rate to protect compressor and water pump in the event of insufficient water flow.

**5. Backup electric heater:**

Provides additional heating capacity when the heating capacity of the heat pump is insufficient due to very low outdoor temperature. Also protects the external water piping from freezing.

**6. Manometer:**

Provides water circuit pressure readout.

**7. Water pump:**

Circulates water in the water circuit.

# S-Therm Yukon split series

## 5 Refrigerant Flow Diagrams

### Heating and domestic hot water operation

Figure 2-3.1: Refrigerant flow during heating or domestic hot water operation

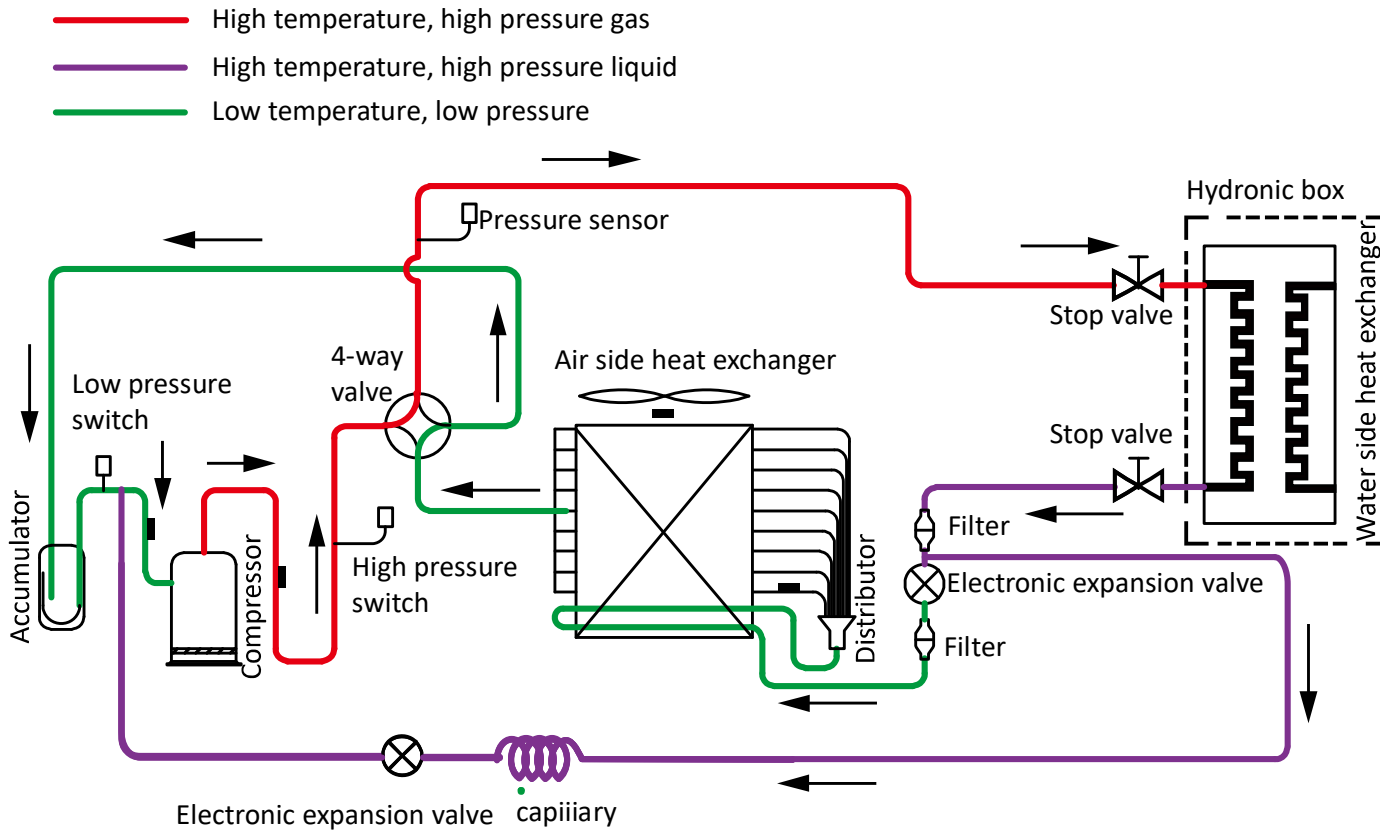

**Cooling and defrosting operation**
*Figure 2-3.2: Refrigerant flow during cooling and defrosting operations*

- High temperature, high pressure gas
- High temperature, high pressure liquid
- Low temperature, low pressure

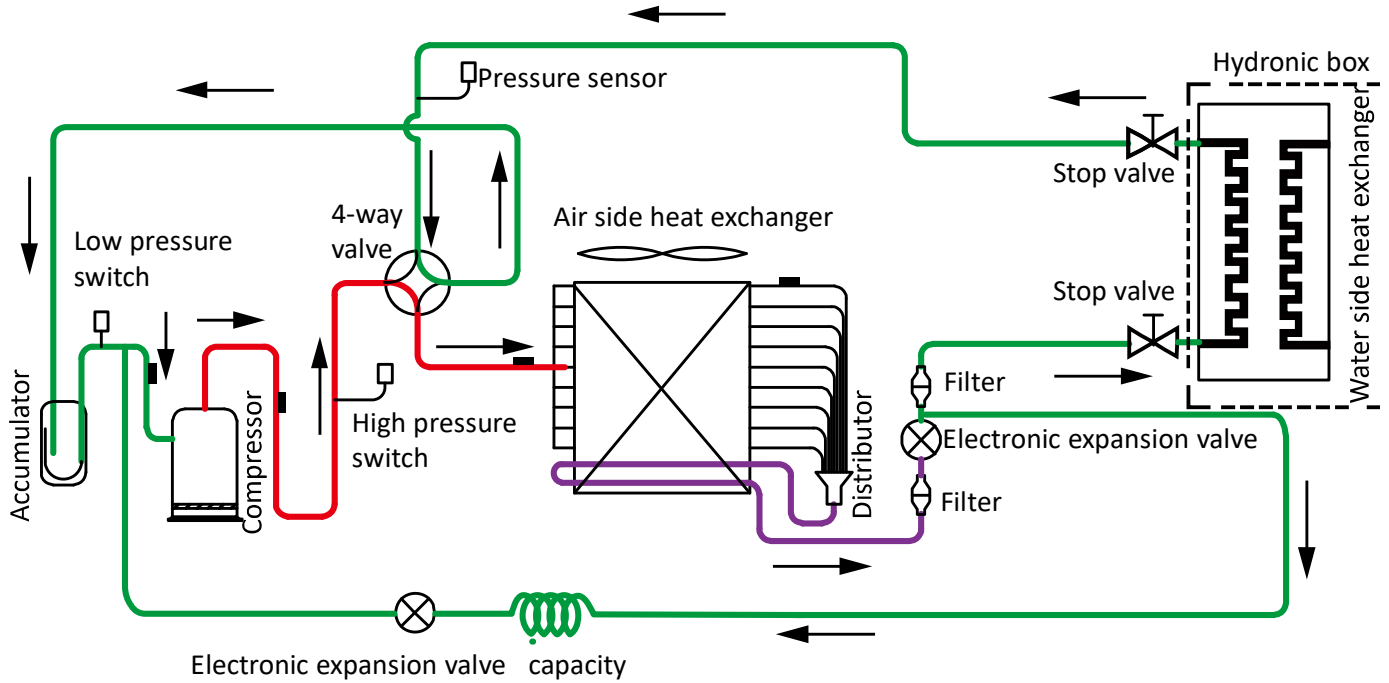

# Part 3

# Control

<b>1 Stop Operation.....</b>	<b>199</b>
<b>2 Standby Control .....</b>	<b>199</b>
<b>3 Startup Control .....</b>	<b>20</b>
<b>4 Normal Operation Control.....</b>	<b>233</b>
<b>5 Protection Control.....</b>	<b>244</b>
<b>6 Special Control .....</b>	<b>277</b>
<b>7 Role of Temperature Sensors in Control Functions.....</b>	<b>30</b>

## **1 Stop Operation**

The stop operation occurs for one of the following reasons:

1. Abnormal shutdown: in order to protect the compressors, if an abnormal state occurs the system makes a stop with thermo off operation and an error code is displayed on the outdoor unit PCB digital displays and on the user interface.
2. The system stops when the set temperature has been reached.

## **2 Standby Control**

### **2.1 Crankcase Heater Control**

The crankcase heater is used to prevent refrigerant from mixing with compressor oil when the compressors are stopped. The crankcase heater is controlled according to outdoor ambient temperature and the compressor on/off state. When the outdoor ambient temperature is above 8°C or the compressor is running, the crankcase heater is off; when the outdoor ambient temperature is at or below 8°C and either the compressor has been stopped for more than 3 hours or the unit has just been powered-on (either manually or when the power has returned following a power outage), the crankcase heater turns on.

### **2.2 Water Pump Control**

When the outdoor unit is in standby, the internal and external circulator pumps run continuously.

# S-Therm Yukon split series

## 3 Startup Control

### 3.1 Compressor Startup Delay Control

In initial startup control and in restart control (except in oil return operation and defrosting operation), compressor startup is delayed such that a minimum of the set re-start delay time has elapsed since the compressor stopped, in order to prevent frequent compressor on/off and to equalize the pressure within the refrigerant system. The compressor re-start delays for cooling and heating modes are set on the user interface. Refer to the S-Therm Yukon Engineering Data Book Part 3, 8.5 “COOL MODE SETTING Menu” and Part 3, 8.6 “HEAT MODE SETTING Menu”.

### 3.2 Compressor Startup Program

In initial startup control and in re-start control, compressor startup is controlled according to outdoor ambient temperature. Compressor startup follows one of two startup programs until the target rotation speed is reached. Refer to Figure 3-3.1, Figure 3-3.2.

Figure 3-3.1: MSH-60EB compressor startup program<sup>1</sup> when ambient temperature is above 3°C

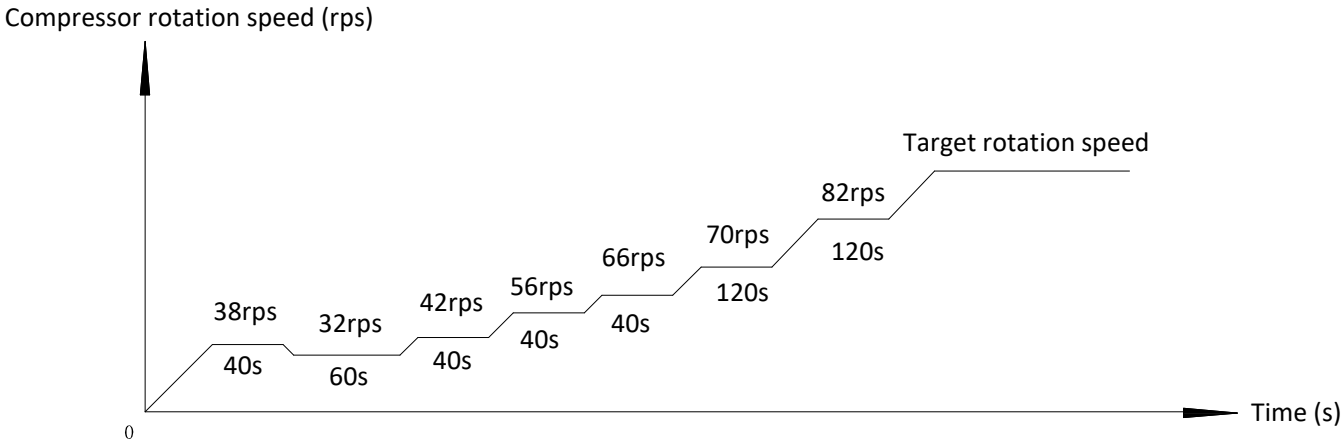

Notes:

- Once the first, 40-second stage of the program is complete, the program proceeds to the subsequent stages in a step-by-step fashion and exits when the target rotation speed has been reached.

Figure 3-3.2: MSH-60EB compressor startup program<sup>1</sup> when ambient temperature is at or below 3°C

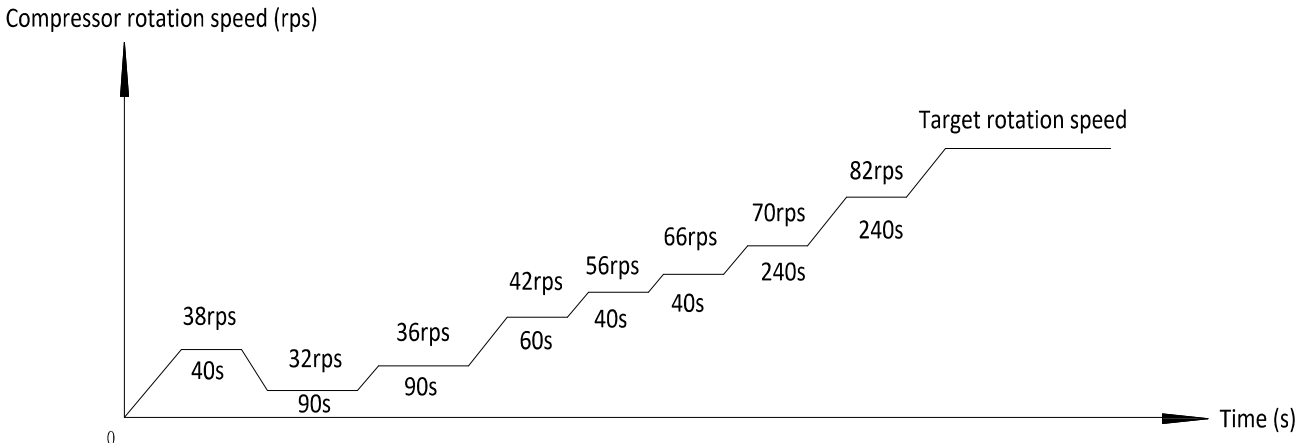

Notes:

- Once the first, 40-second stage of the program is complete, the program proceeds to the subsequent stages in a step-by-step fashion and exits when the target rotation speed has been reached.

Figure 3-3.3: MSH-80EB; MSH-100EB compressor startup program<sup>1</sup> when ambient temperature is above 11°C

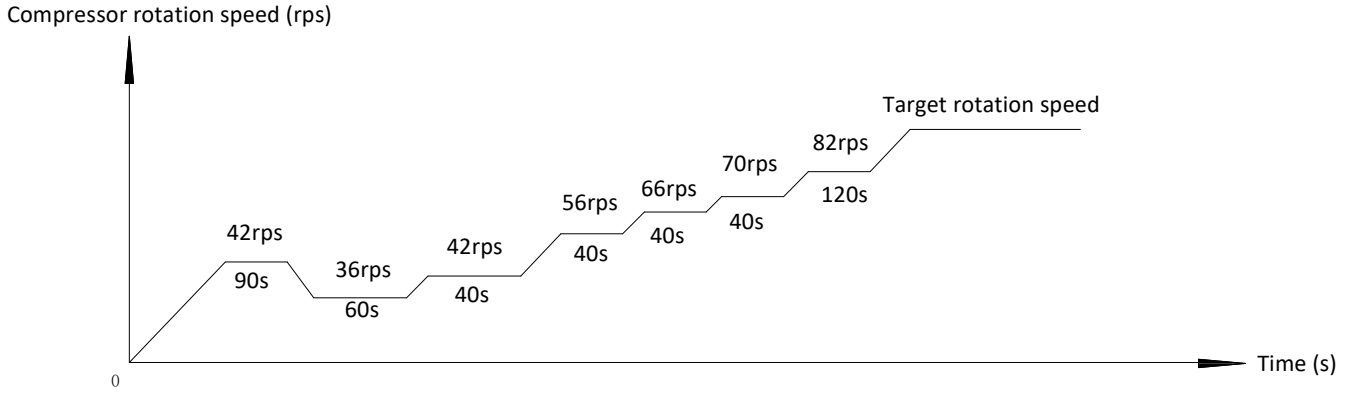

Notes:

- Once the first, 90-second stage of the program is complete, the program proceeds to the subsequent stages in a step-by-step fashion and exits when the target rotation speed has been reached.

Figure 3-3.4: MSH-80EB; MSH-100EB compressor startup program<sup>1</sup> when ambient temperature is at or below 11°C

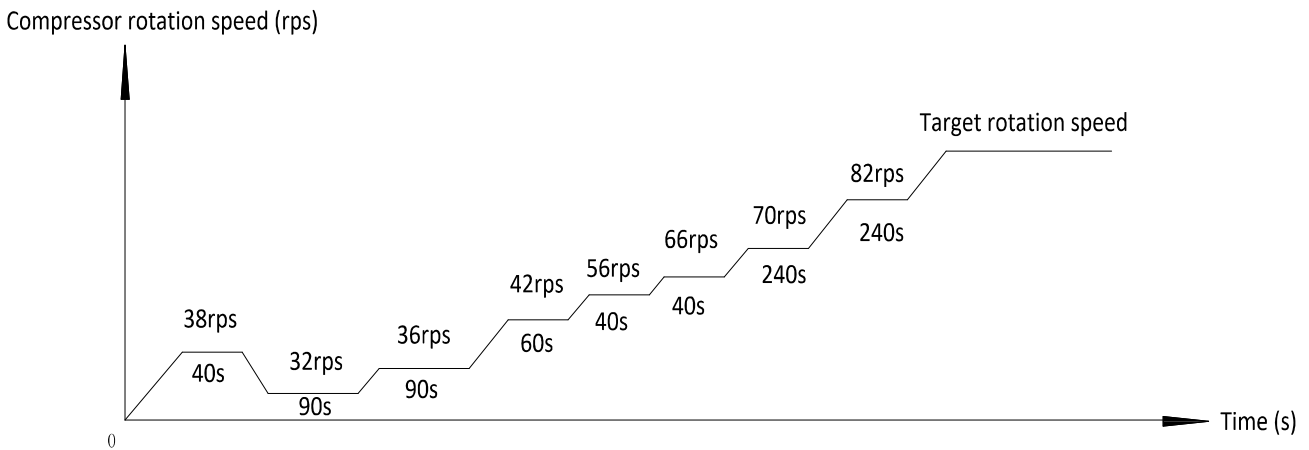

Notes:

- Once the first, 40-second stage of the program is complete, the program proceeds to the subsequent stages in a step-by-step fashion and exits when the target rotation speed has been reached.

Figure 3-3.5: MSH-120EB; MSH-140EB; MSH-160EB; MSH-120EB-3; MSH-140EB-3; MSH-160EB-3 compressor startup program<sup>1</sup> when ambient temperature is above 3°C

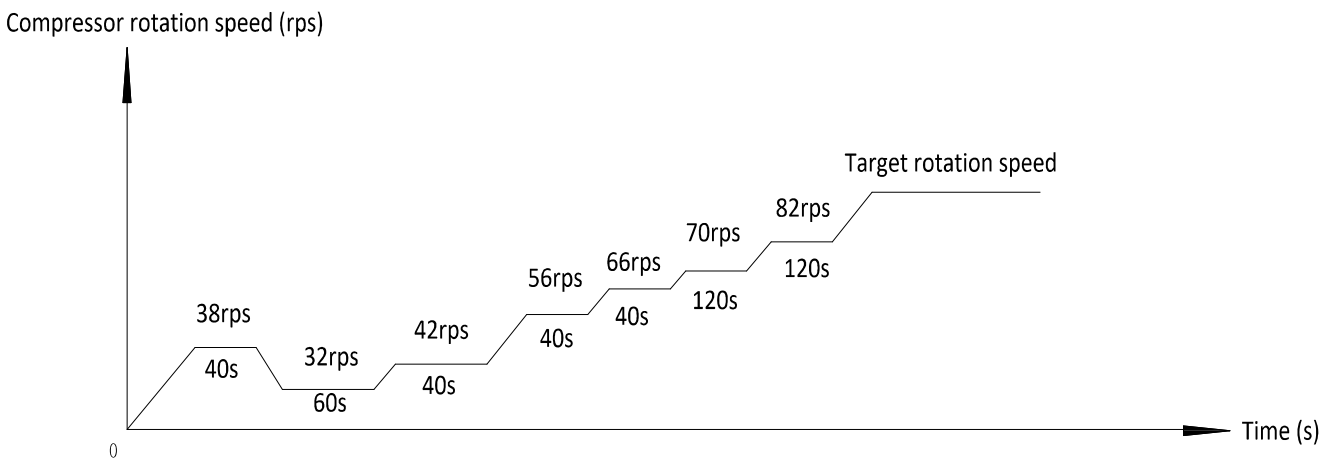

Notes:

- Once the first, 40-second stage of the program is complete, the program proceeds to the subsequent stages in a step-by-step fashion and exits when the target rotation speed has been reached.

Figure 3-3.6: MSH-120EB; MSH-140EB; MSH-160EB; MSH-120EB-3; MSH-140EB-3; MSH-160EB-3 compressor startup program<sup>1</sup> when ambient temperature is at or below 3°C

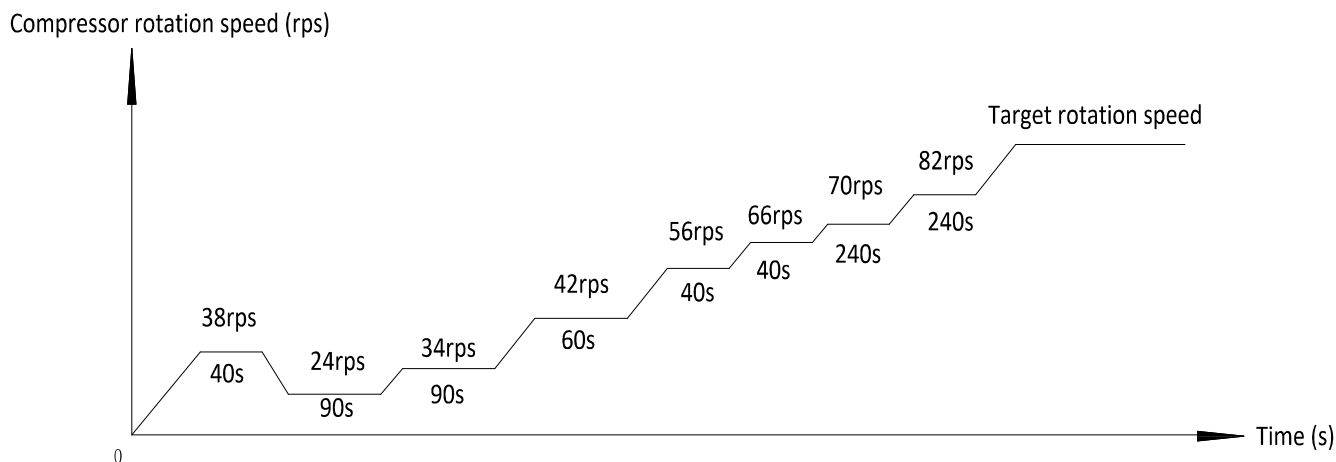

Notes:

- Once the first, 40-second stage of the program is complete, the program proceeds to the subsequent stages in a step-by-step fashion and exits when the target rotation speed has been reached.

### 3.3 Startup Control for Heating and Domestic Hot Water Operation

Table 3-3.1: Component control during startup in heating and domestic hot water modes

Component	Wiring diagram label	4-16kW	Control functions and states
Inverter compressor	COMP	●	Compressor startup program selected according to ambient temperature <sup>1</sup>
DC fan motor	FAN	●	Fan run at maximum speed <sup>2</sup>
Electronic expansion valve	EXV	●	Position (steps) from 0 (fully closed) to 480 (fully open), controlled according to outdoor ambient temperature, discharge temperature, suction superheat,
Four-way valve	4-WAY	●	On

Notes:

- Refer to Part 3, 3.2 "Compressor Startup Program".
- Refer to Table 3-4.3 in Part 3, 4.6 "Outdoor Fan Control".

### 3.4 Startup Control for Cooling Operation

Table 3-3.2: Component control during startup in cooling mode

Component	Wiring diagram label	4-16kW	Control functions and states
Inverter compressor	COMP	●	Compressor startup program selected according to ambient temperature <sup>1</sup>
DC fan motor	FAN	●	Fan run at maximum speed <sup>2</sup>
Electronic expansion valve	EXV	●	Position (steps) from 0 (fully closed) to 480 (fully open), controlled according to outdoor ambient temperature, discharge temperature, suction superheat
Four-way valve	4-WAY	●	Off

Notes:

- Refer to Part 3, 3.2 "Compressor Startup Program".
- Refer to Table 3-4.3 in Part 3, 4.6 "Outdoor Fan Control".

## 4 Normal Operation Control

### 4.1 Component Control during Normal Operation

Table 3-4.1: Component control during heating and domestic hot water operations

Component	Wiring diagram label	4-16kW	Control functions and states
Inverter compressor	COMP	•	Controlled according to load requirement from hydronic system
DC fan motor	FAN	•	Controlled according to outdoor heat exchanger pipe temperature
Electronic expansion valve	EXV	•	Position (steps) from 0 (fully closed) to 480 (fully open), controlled according to discharge temperature, suction superheat and compressor speed
Four-way valve	4-WAY	•	On

Table 3-4.2: Component control during cooling operation

Component	Wiring diagram label	4-16kW	Control functions and states
Inverter compressor	COMP	•	Controlled according to load requirement from hydronic system
DC fan motor	FAN	•	Controlled according to outdoor heat exchanger pipe temperature
Electronic expansion valve	EXV	•	Position (steps) from 0 (fully closed) to 480 (fully open), controlled according to discharge temperature, suction superheat and compressor speed
Four-way valve	4-WAY	•	Off

### 4.2 Compressor Output Control

The compressor rotation speed is controlled according to the load requirement. Before compressor startup, the S-Therm Yukon outdoor unit determines the compressor target speed according to outdoor ambient temperature, leaving water set temperature and actual leaving water temperature and then runs the appropriate compressor startup program. Refer to Part 3, 3.2 “Compressor Startup Program”. Once the startup program is complete, the compressor runs at the target rotation speed.

### 4.3 Compressor Step Control

The running speed of six-pole compressors in rotations per second (rps) is one third of the frequency (in Hz) of the electrical input to the compressor motor. The frequency of the electrical input to the compressor motors can be altered at a rate of 1Hz per second.

### 4.4 Four-way Valve Control

The four-way valve is used to change the direction of refrigerant flow through the water side heat exchanger in order to switch between cooling and heating/DHW operations. Refer to Part 2, 3 “Refrigerant Flow Diagrams”. During heating and DHW operations, the four-way valve is on; during cooling and defrosting operations, the four-way valve is off.

### 4.5 Electronic Expansion Valve Control

The position of the electronic expansion valve (EXV) is controlled in steps from 0 (fully closed) to 480 (fully open).

- At power-on:
  - The EXV first closes fully, then moves to the standby position. After a few seconds the EXV moves to an initial running position, which is determined according to operating mode and outdoor ambient temperature. After a further a few minutes, the EXV is controlled according to suction superheat and discharge temperature. Once a further a few minutes have elapsed, the EXV is then controlled according to suction superheat, discharge temperature and compressor speed.
- When the outdoor unit is in standby:
  - The EXV is at standby position.

## S-Therm Yukon split series

- When the outdoor unit stops:
  - The EXV first closes fully, then moves to the standby position.

### 4.6 Outdoor Fan Control

The speed of the outdoor unit fan is adjusted in steps, as shown in Table 3-4.1.

Table 3-4.3: Component control during cooling operation

Fan speed index	Fan speed (rpm)		
	4/6/8/10kW	12/14kW	16kW
W1	200	200	200
W2	250	250	250
W3	300	300	300
W4	350	350	350
W5	400	400	400
W6	450	450	450
W7	500	500	500
W8	530	550	550
W9	550	580	600
W10	580	610	650
W11	600	630	700
W12	600	650	730

## 5 Protection Control

### 5.1 High Pressure Protection Control

This control protects the refrigerant system from abnormally high pressure and protects the compressor from transient spikes in pressure.

Figure 3-5.1: High pressure protection control

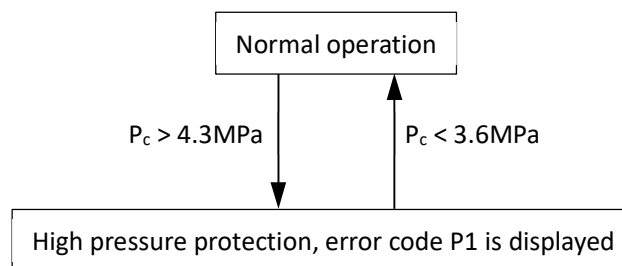

Notes:

1.  $P_c$ : Discharge pressure

When the discharge pressure rises above 4.3MPa the system displays P1 protection and the unit stops running. When the discharge pressure drops below 3.6MPa, the compressor enters re-start control.

### 5.2 Low Pressure Protection Control

This control protects the refrigerant system from abnormally low pressure and protects the compressor from transient drops in pressure.

Figure 3-5.2: Low pressure protection control

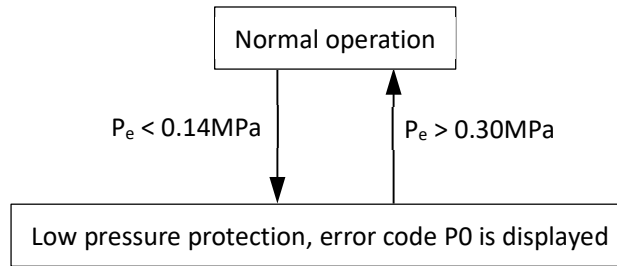

Notes:

1.  $P_e$ : Suction pressure

When the suction pressure drops below 0.14MPa the system displays P0 protection and the unit stops running. When the suction pressure rises above 0.3MPa, the compressor enters re-start control.

### 5.3 Discharge Temperature Protection Control

This control protects the compressor from abnormally high temperatures and transient spikes in temperature.

Figure 3-5.3: High discharge temperature protection control

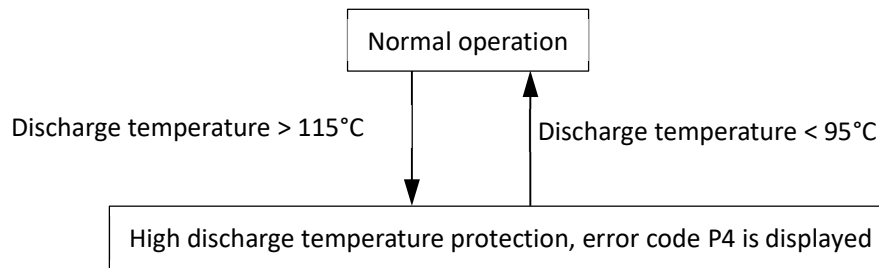

When the discharge temperature rises above 115°C the system displays P4 protection and the unit stops running. When the discharge temperature drops below 95°C, the compressor enters re-start control.

Figure 3-5.4: Low discharge temperature protection control

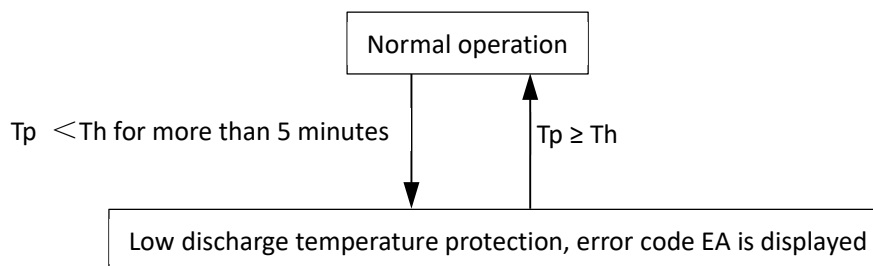

When the discharge temperature is lower than suction temperature for more than 5 minutes, the system displays EA protection and the unit stops running. When the discharge temperature is higher than suction temperature, the compressor enters re-start control.

### 5.4 Compressor Current Protection Control

This control protects the compressor from abnormally high currents.

Figure 3-5.5: Compressor current protection control

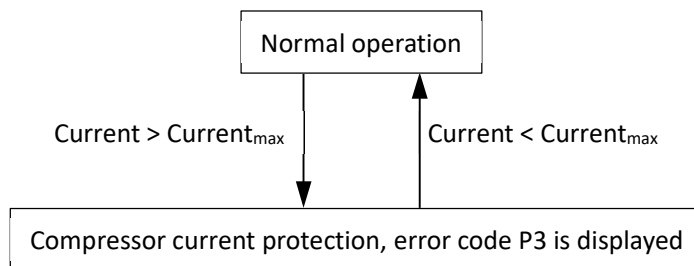

Model name	MSH-60EB	MSH-80EB MSH-100EB	MSH-120EB MSH-140EB MSH-160EB	MSH-120EB-3 MSH-140EB-3 MSH-140EB-3
Current <sub>max</sub>	18A	19A	30A	14A

When the compressor current rises above Current<sub>max</sub> the system displays P3 protection and the unit stops running. When the compressor current drops below Current<sub>max</sub>, the compressor enters re-start control.

### 5.5 Voltage Protection Control

This control protects the S-Therm Yukon from abnormally high or abnormally low voltages.

Figure 3-5.6: Compressor voltage protection control

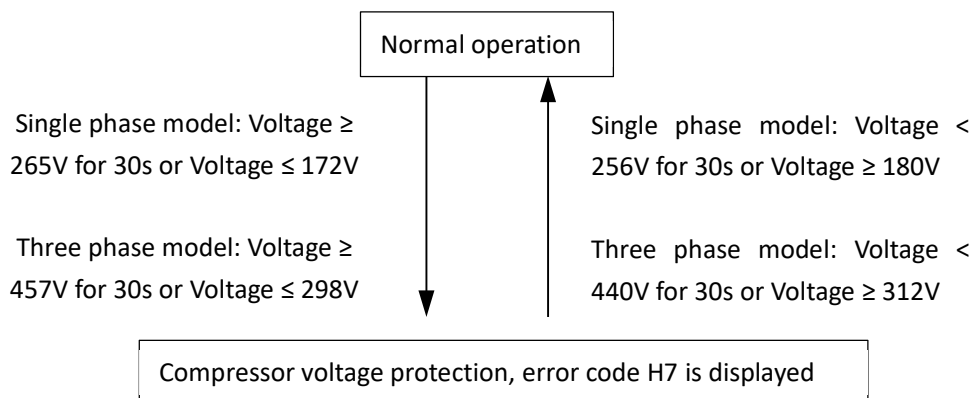

For single phase models, when the phase voltage of AC power supply is at or above 265V for more than 30 seconds, the system displays H7 protection and the unit stops running. When the phase voltage drops below 265V for more than 30 seconds, the refrigerant system restarts once the compressor re-start delay has elapsed. When the phase voltage is below 172V, the system displays H7 protection and the unit stops running. When the AC voltage rises to more than 180V, the refrigerant system restarts once the compressor re-start delay has elapsed.

For three phase models, when the phase voltage of AC power supply is at or above 457V for more than 30 seconds, the system displays H7 protection and the unit stops running. When the phase voltage drops below 440V for more than 30 seconds, the refrigerant system restarts once the compressor re-start delay has elapsed. When the phase voltage is below 298V, the system displays H7 protection and the unit stops running. When the AC voltage rises to more than 312V, the refrigerant system restarts once the compressor re-start delay has elapsed.

### 5.6 DC Fan Motor Protection Control

This control protects the DC fan motors from strong winds and abnormal power supply. DC fan motor protection occurs when any one of the following the following three sets of conditions are met:

- Outdoor ambient temperature is at or above 4°C and actual fan speed differs from target fan speed by 200rpm or more for more than 3 minutes.
- Outdoor ambient temperature is below 4°C and actual fan speed differs from target fan speed by 300rpm or more for more than 3 minutes.

- Actual fan speed is less than 150rpm for more than 90 seconds.

When DC fan motor protection control occurs the system displays the H6 error code and the unit stops running. After 3 minutes, the unit restarts automatically. When H6 protection occurs 10 times in 120 minutes, the HH error is displayed. When an HH error occurs, a manual system restart is required before the system can resume operation.

### 5.7 Water Side Heat Exchanger Anti-freeze Protection Control

This control protects the water side heat exchanger from ice formation.

In cooling mode, if inlet water temperature or leaving water temperature or auxiliary heat source leaving water temperature is below 4°C, heat pump stops and water pump keeps running for 30min. If water temperature is still below 4°C, heat pump turns to heating mode.

In heating/DHW standby mode, if ambient temperature is below 3°C and inlet water temperature or leaving water temperature or auxiliary heat source leaving water temperature is below 5°C, heat pump stops and water pump keeps running for 30min. If ambient temperature is still below 3°C and water temperature is still below 5°C, heat pump turns to heating mode.

In heating/DHW standby mode, if leaving water temperature is below 2°C, heat pump stops and water pump keeps running for 30min. If water temperature is still below 2°C heat pump turns to heating mode to protect from anti-freezing.

When water side heat exchanger anti-freeze protection occurs the system displays error code Pb and the unit stops running.

## 6 Special Control

### 6.1 Oil Return Operation

In order to prevent the compressor from running out of oil, the oil return operation is conducted to recover oil that has flowed out of the compressor and into the refrigerant piping.

The oil return operation starts when the following condition occurs:

- When the compressor cumulative operating time reaches 6 hours.

The oil return operation ceases when any one of the following three conditions occurs:

- Oil return operation duration reaches 5 minutes.
- Compressor stops.

Tables 3-6.1 show component control during oil return operation in cooling mode.

Component	Wiring diagram label	4-16kW	Control functions and states
Inverter compressor	COMP	●	Runs at oil return operation rotation speed
DC fan motor	FAN	●	Controlled according to cooling mode
Electronic expansion valve	EXV	●	304 (steps)
Four-way valve	4-WAY	●	Off

Tables 3-6.2 show component control during oil return operation in heating and DHW modes.

Component	Wiring diagram label	4-16kW	Control functions and states
Inverter compressor	COMP	●	Runs at oil return operation rotation speed
DC fan motor	FAN	●	Controlled according to heating mode
Electronic expansion valve	EXV	●	304 (steps)
Four-way valve	4-WAY	●	On

### 6.2 Defrosting Operation

In order to recover heating capacity, the defrosting operation is conducted when the outdoor unit air side heat exchanger is performing as a condenser. The defrosting operation is controlled according to outdoor ambient temperature, air side heat

## S-Therm Yukon split series

exchanger refrigerant outlet temperature and the compressor running time.

Table 3-6.3: Component control during defrosting operation

Component	Wiring diagram label	4-16kW	Control functions and states
Inverter compressor	COMP	•	Runs at defrosting operation rotation speed
DC fan motor	FAN	•	Off
Electronic expansion valve	EXV	•	480 (steps)
Four-way valve	4-WAY	•	Off

### 6.3 Force Cooling Operation

The force cooling operation helps the refrigerant recovering before removal the water side heat exchanger.

The force cool mode can be ended by pushing the button on the outdoor refrigerant system main PCB named "FORCE" for 5s or this mode will be ended automatic if the system has operated force cool mode for more than 30 minutes.

Table 3-6.4: Component control during force cool operation

Component	Wiring diagram label	4-16kW	Control functions and states
Inverter compressor	COMP	•	Runs at force cooling operation rotation speed
DC fan motor	FAN	•	Runs at force cooling operation speed
Electronic expansion valve	EXV	•	304 (steps)
Four-way valve	4-WAY	•	Off

### 6.4 Fast DHW Operation

Fast DHW operation is used to quickly meet a requirement for domestic hot water when DHW priority has been set on the user interface.

Domestic hot water demand priority can be ended by changing the switch on controller from "on" to "off".

Table 3-6.5: Component control during fast DHW operation

Component	Wiring diagram label	4/6kW	8/10/12/14/16kW	Control functions and states
Inverter compressor	COMP	•	•	Controlled according to load requirement
DC fan motor	FAN	•	•	Controlled according to outdoor heat exchanger pipe temperature
Electronic expansion valve	EXV	•	•	Position (steps) from 0 (fully closed) to 480 (fully open), controlled according to discharge superheat
Four-way valve	ST	•	•	On
Tank electric heater	TBH	•	•	On

### 6.5 Two zones control<sup>1</sup>

Two zones control function is used to control temperature of each zone separately, thus different type radiator will operate at its optimal temperature and water pump cycle time will be reduced to save energy.

- Cooling mode

In two zones control for cooling mode, when the setting temperature of a certain zones is reached, the zone and water pump of this zone will turn off.

- Heating mode

In two zones control for heating mode, the on/off control of zone and water pump is same with cooling mode, but in addition, the mixing valve (3-way valve SV3) control function will be activated to adjust the water temperature of the low temperature zone by control the opening time and closing time of the valve. The mixing valve will only turn on when two zones control for heating is activated. On other conditions, the mixing valve will keep off. When the valve initially turns on, the opening time and closing time is same and then the time is controlled according to the difference between water pipe temperature and setting water temperature of the controlling zone.

- Hydraulic adapter PCB (Optional)

With the help of hydraulic adapter PCB, totally 8 thermostats can be used at the same time for maximum 8 rooms to control heat pump.

*Note:*

1. *M thermal units just have the controlling function, while the mixing valve, water pump of each zone need to be field supplied and connect to M thermal unit.*

## 6.6 Smart grid control

Unit adjusts the operation according to different electrical signals to realize energy saving.

Free electric energy signal: DHW mode turn on, the setting temperature will be changed to 70°C automatically, and the TBH operate as below:  $T5 < 69$ , the TBH is on,  $T5 \geq 70$ , the TBH is off. The unit operates in cooling/heating mode as the normal logic.

Common electric energy signal: unit operates according to users' need.

Expensive electric energy signal: only available for cooling or heating mode and user can set the maximum operating time.

## 6.7 Balance tank temperature control

Balance tank temperature sensor is used to control on/off of heat pump.

Once the heat pump stops, internal pump stops to save energy and then balance tank provides hot water for space heating. In addition, balance tank temperature control can meet both space heating and domestic hot water needs at the same time. Balance tank can store energy to provide hot water whilst heat pump runs heat mode/cooling, which can reduce the host selection and the initial investment.

## 6.8 USB data transfer

- Convenient program upgrade

No need to carry any other heavy equipment but only USB can realize program upgrade of indoor unit and outdoor unit.

- Parameter setting transmission between wired controllers

Installer can quickly copy the setting from one controller to another via USB, which save the time of on-site installation.

## 6.9 Dry contract M1M2 control

## S-Therm Yukon split series

M1M2 can be set in the wired controller for heat pump on/off control, TBH control, AHS control.

- For heat pump on/off control

When dry contract closes for 1s, heat pump stops. When dry contract opens for 5s, heat pump on/off according to wired controller or room thermostat setting.

- For TBH control

TBH is only controlled by M1M2. If dry contract closes,  $T5 < 65^{\circ}\text{C}$  then TBH opens until water tank temperature reaches  $70^{\circ}\text{C}$ .

- For AHS control

In heating mode, AHS on/off is only controlled by M1M2. In DHW mode, M1M2 control does not affect AHS on/off.

## 7 Role of Temperature Sensors in Control Functions

Table 3-7.1: Names of the temperature sensors

Number	Sensor name	Sensor code
1	Suction pipe temperature sensor	Th
2	Discharge pipe temperature sensor	Tp
3	Outdoor ambient temperature sensor	T4
4	Air side heat exchanger refrigerant outlet temperature sensor	T3
5	Water side heat exchanger refrigerant outlet (gas pipe) temperature sensor	T2B
6	Water side heat exchanger refrigerant outlet (liquid pipe) temperature sensor	T2
7	Water side heat exchanger water outlet temperature sensor	Tw_out
8	Water side heat exchanger water inlet temperature sensor	Tw_in
9	Final water outlet temperature sensor	T1
10	Domestic hot water tank temperature sensor	T5
11	Room temperature sensor (built in wired controller)	Ta

Figure 3-7.1: Location of the temperature sensors on Sinclair Yukon

Notes:

1. The names and functions of the temperature sensors labelled 1 to 11 in this figure are detailed in Table 3-7.1.

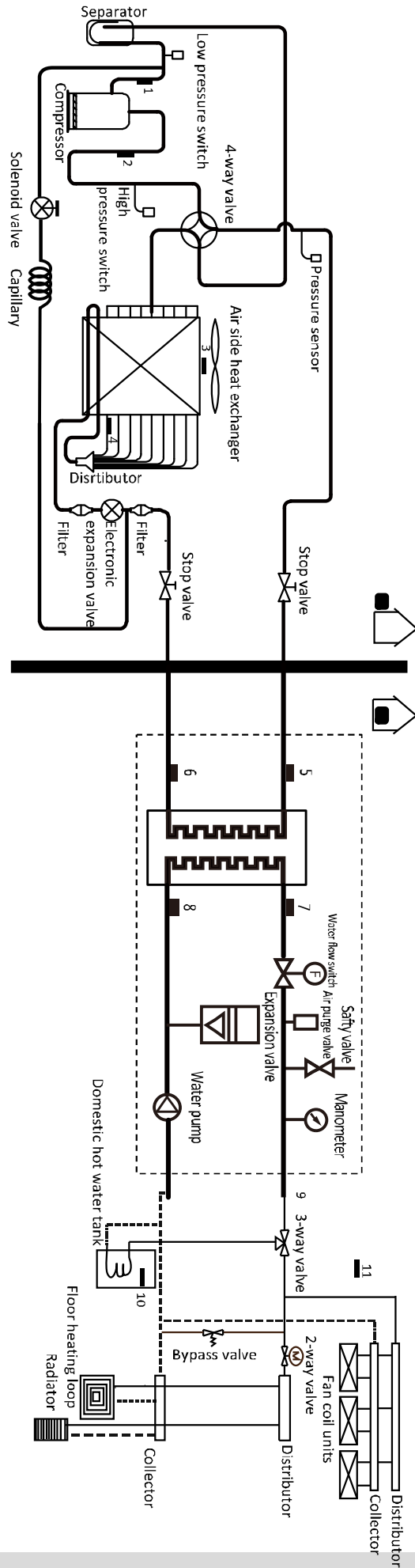

# Part 4

# Diagnosis and Troubleshooting

<b>1 Electric Control Box Layout.....</b>	<b>333</b>
<b>2 PCBs.....</b>	<b>367</b>
<b>3 Error Code Table.....</b>	<b>50</b>
<b>4 Troubleshooting.....</b>	<b>52</b>
<b>5 Appendix to Part 4 .....</b>	<b>110</b>

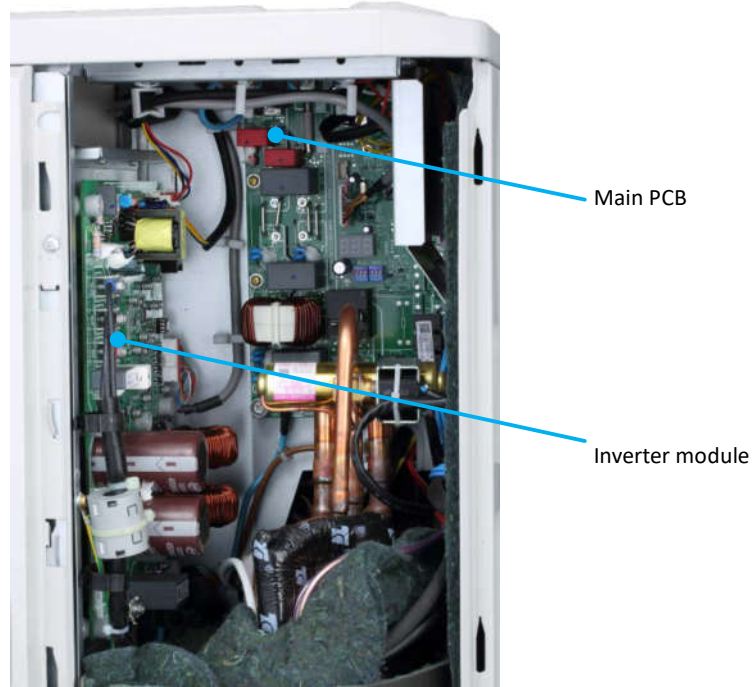
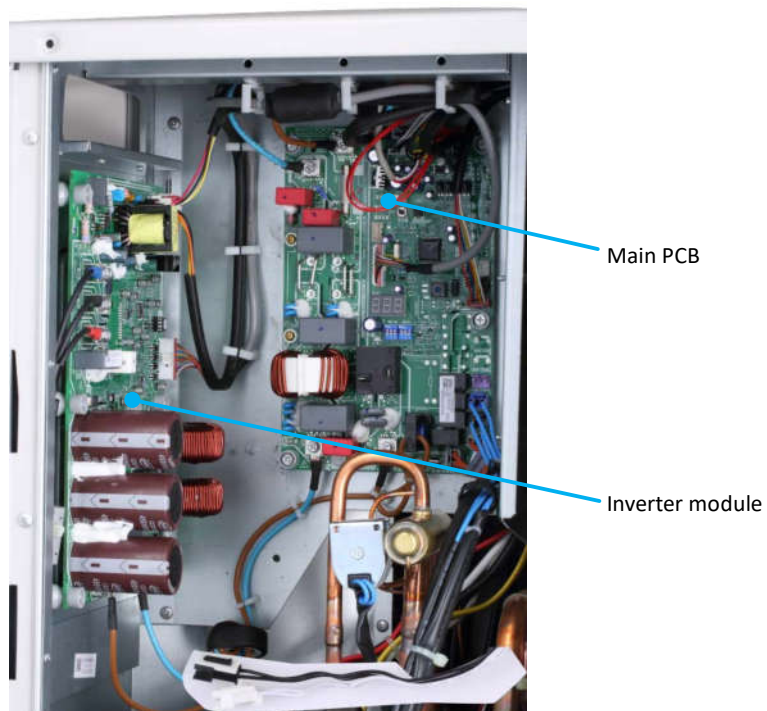
**1 Electric Control Box Layout****1.1 Outdoor Unit Electric Control Box Layout***Figure 4-1.1: MSH-60EB electric control box**Figure 4-1.2: MSH-80EB, MSH-100EB electric control box*

# S-Therm Yukon split series

Figure 4-1.3: MSH-120EB; MSH-140EB; MSH-160EB electric control box

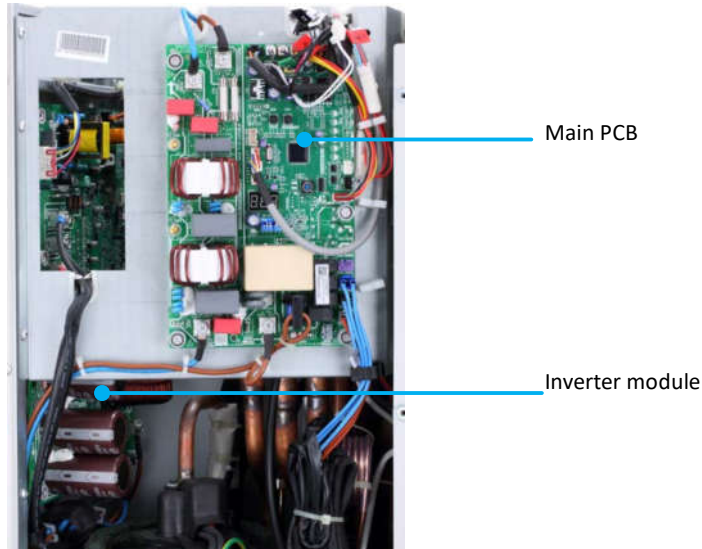
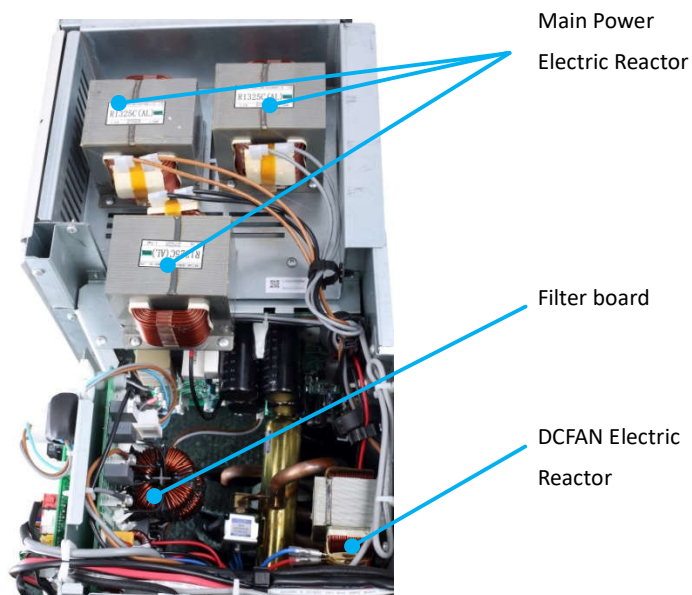
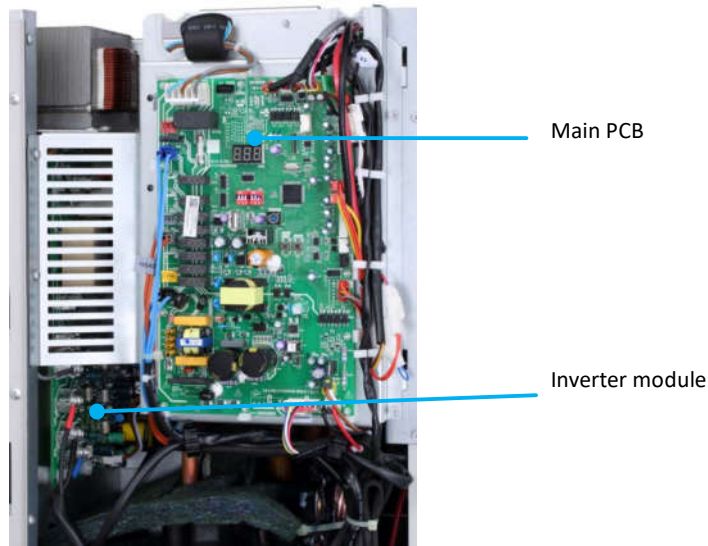

Figure 4-1.4: MSH-120EB-3; MSH-140EB-3; MSH-160EB-3 electric control box



**1.2 Hydronic Box Electric Control Box Layout**

*Figure 4-1.5: MSH-60IB; MSH-60IB/3; MSH-100IB; MSH-100IB/3; MSH-100IB-3/9;  
MSH-160IB; MSH-160IB/3; MSH-160IB-3/9*



# S-Therm Yukon split series

## 2 PCBs

### 2.1 Outdoor Unit PCBs

There are one type of main PCB for the 4kW to 16kW models. In addition to the main PCB, all models have an inverter module.

The locations of each PCB in the outdoor unit electric control box are shown in Figures 4-1.1 to Figure 4-1.4 in Part 4, 1.1 “Outdoor Unit Electric Control Box Layout”. The locations of each PCB in the hydronic box electric control box are shown in Figures 4-1.5 in Part 4, 1.2 “Hydronic Box Electric Control Box Layout”.

### 2.2 Main PCB for Hydronic System

Figure 4-2.1: MSH-60IB; MSH-60IB/3; MSH-100IB; MSH-100IB/3; MSH-100IB-3/9; MSH-160IB; MSH-160IB/3; MSH-160IB-3/9

hydronic box main PCB

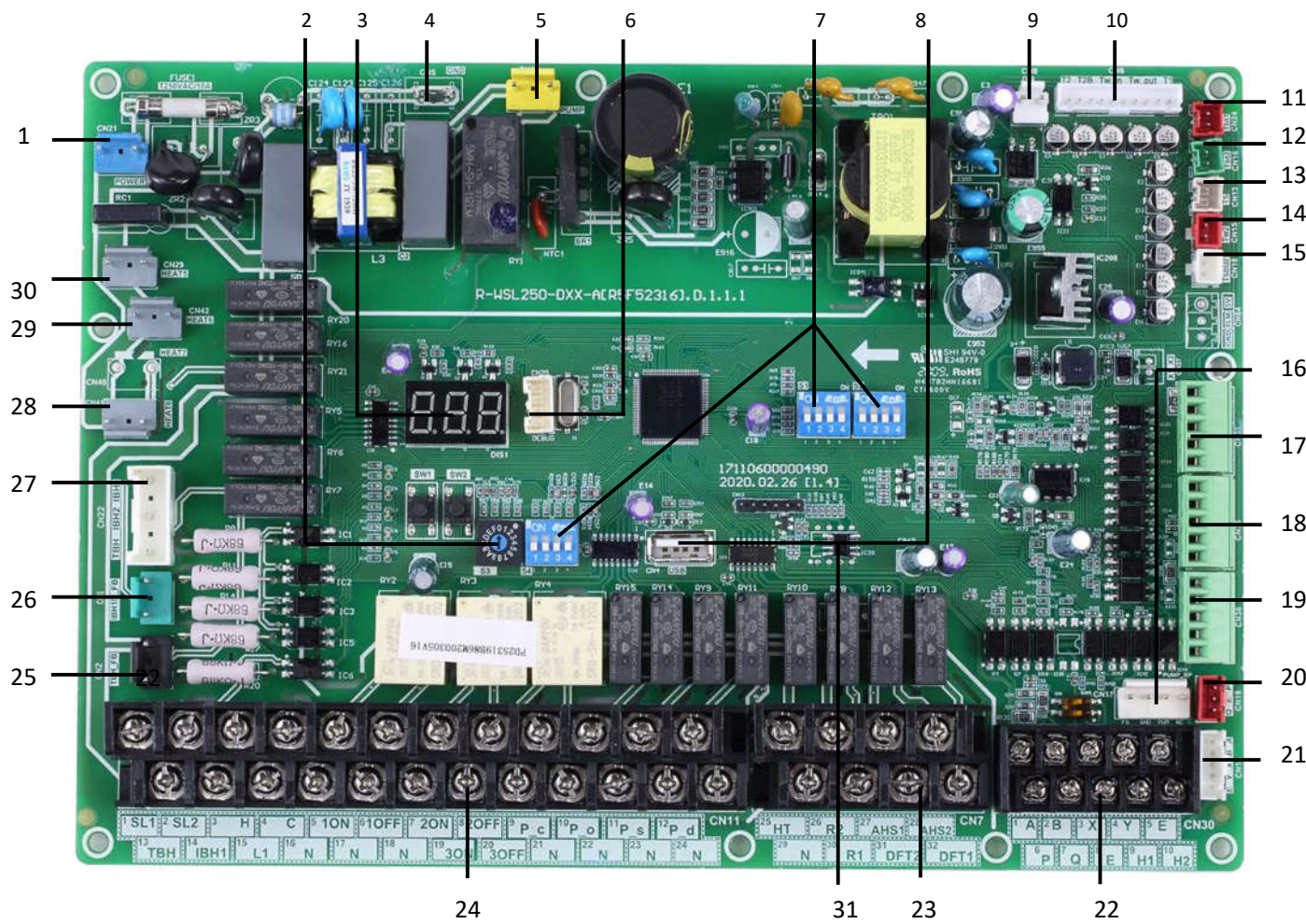

*Table 4-2.1: MSH-60IB; MSH-60IB/3; MSH-100IB; MSH-100IB/3; MSH-100IB-3/9; MSH-160IB; MSH-160IB/3; MSH-160IB-3/9*
*hydronic box main PCB*

<b>Label in Figure 4-2.1</b>	<b>Code</b>	<b>Content</b>
1	CN21	Port for power supply
2	S3	Rotary dip switch
3	DIS1	Digital display
4	CN5	Port for ground
5	CN28	Port for variable speed pump power input
6	CN25	Port for IC programming
7	S1,S2,S4	Dip switch
8	CN4	Port for USB programming
9	CN8	Port for Flow switch
10	CN6	Port for temp. sensors (T2,T2B,TW_out,TW_in, T1,)
11	CN24	Port for temp. sensor(Tbt1, The balanced water tank of up temp. sensor)
12	CN16	Port for temp. sensor(Tbt2, The balanced water tank of up temp. sensor)
13	CN13	Port for temp. sensor(T5, domestic hot water tank temp. sensor)
14	CN15	Port for temp. sensor(Tw2, The outlet water for zone 2 temp. sensor)
15	CN18	Port for temp. sensor(Tsolar, Solar panel temp. sensor)
16	CN17	Port for variable speed pump communication
17	CN31	Control port for room thermostat (heating mode)(HT)/Control port for room thermostat (cooling mode)(CL)/Power port for room thermostat(COM)
18	CN35	Port for smart grid (grid signal, photovoltaic signal)
19	CN36	Port for remote switch, temperature board
20	CN19	Communicate port between indoor unit and outdoor unit
21	CN14	Port for communication with the wired controller
22	CN30	Communicate port between indoor unit and outdoor unit, port for communication with the wired controller, internal machine parallel
23	CN7	Port for antifreeze E-heating tape(external), additional heat source, compressor run/defrost run
24	CN11	Control port for tank booster heater, internal backup heater 1, input port for solar energy, Port for room thermostat, SV1(3-way valve), SV2(3-way valve), SV3(3-way valve), zone 2 pump, outside circulation pump, solar energy pump, DHW pipe pump,
25	CN2	Feedback port for external temp. switch(shorted in default)
26	CN1	Feedback port for temperature switch(shorted in default)
27	CN22	Control port for backup heater1/booster heater/Reserved
28	CN41	Port for anti-freeze electric heating tape
29	CN42	Port for anti-freeze electric heating tape
30	CN29	Port for anti-freeze electric heating tape
31	IC39	EEPROM

# S-Therm Yukon split series

## 2.3 Main PCBs for Refrigerant System, Inverter Module

Figure 4-2.2: MSH-60EB; MSH-80EB; MSH100EB outdoor unit main PCB for refrigerant system

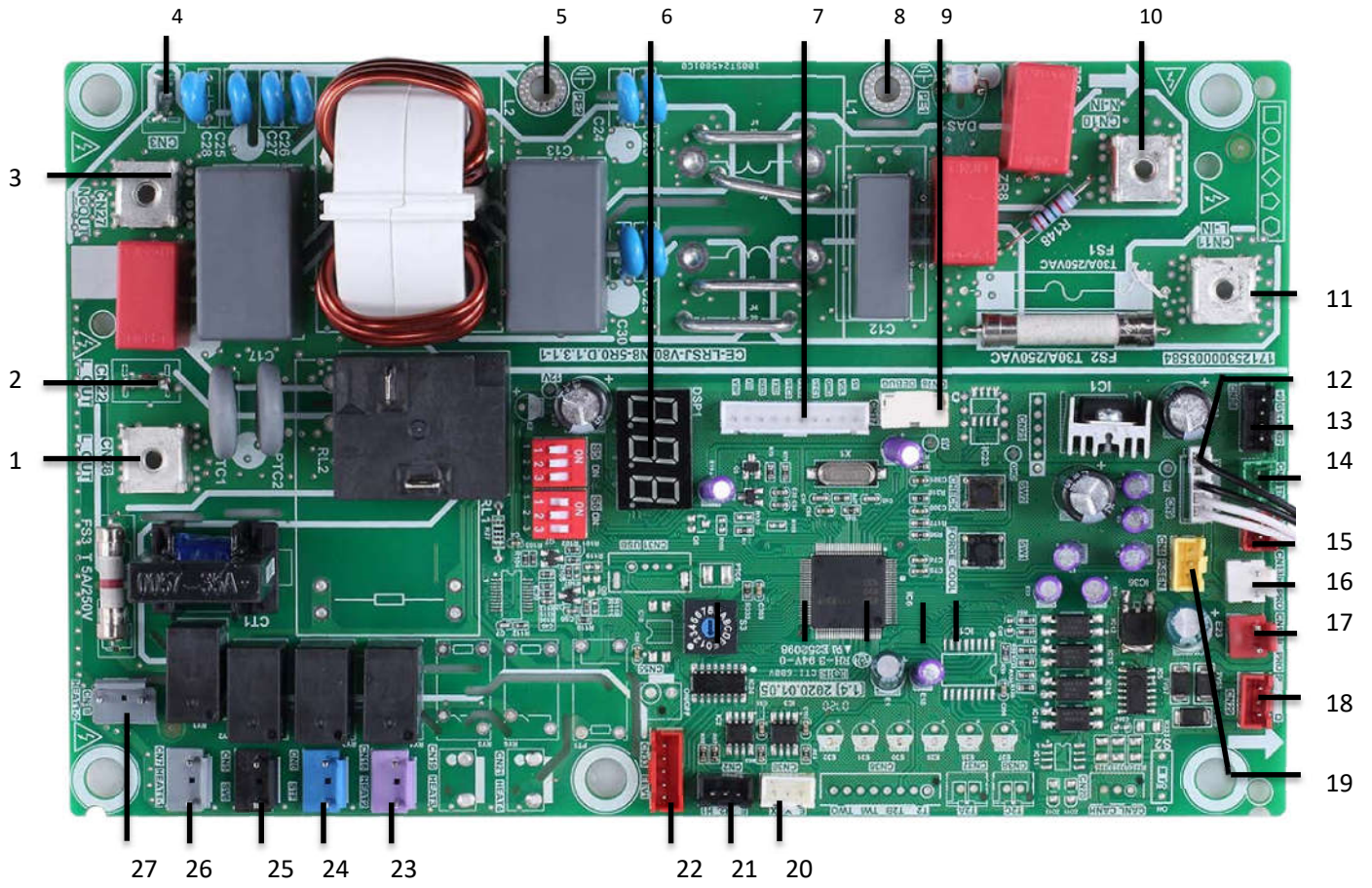
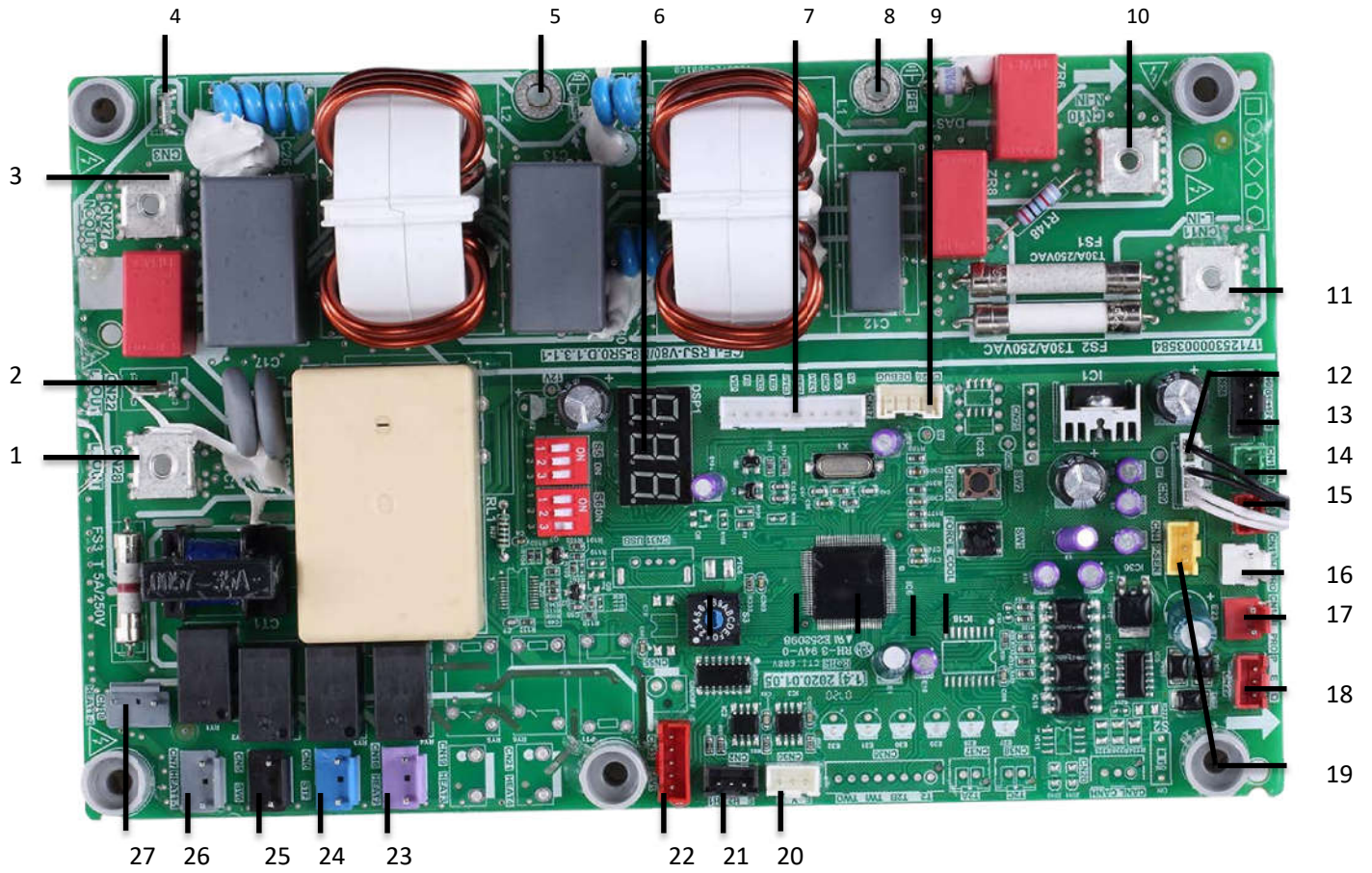

*Table 4-2.2: MSH-60EB; MSH-80EB; MSH100EB outdoor unit main PCB for refrigerant system*

Label in Figure 4-2.2	Code	Content
1	CN28	Output port L to main PCB for refrigerant system
2	CN22	Reserved
3	CN27	Output port N to main PCB for refrigerant system
4	CN3	Reserved
5	PE2	Port for ground wire
6	DSP1	Digital display
7	CN17	Port for communication with main PCB for refrigerant system
8	PE1	Port for ground wire
9	CN26	Reserved
10	CN10	Input port for neutral wire
11	CN11	Input port for live wire
12	CN9	Port for outdoor ambient temp. sensor and condenser temp. sensor
13	CN24	Input port for +12V/9V
14	CN1	Port for suction temp. sensor
15	CN8	Port for discharge temp. sensor
16	CN13	Port for high pressure switch
17	CN14	Port for low pressure switch
18	CN29	Port for communication with hydro-box control board
19	CN4	Port for pressure sensor
20	CN30	Port for communication(reserved)
21	CN2	Port for communication(reserved)
22	CN33	Port for electrical expansion valve
23	CN16	Port for chassis electrical heating tape(Optional)
24	CN6	Port for 4-way valve
25	CN5	Port for SV6 valve
26	CN7	Port for compressor electric heating tape 1
27	CN18	Port for compressor electric heating tape 2

# S-Therm Yukon split series

Figure 4-2.3 MSH-120EB; MSH-140EB; MSH-160EB outdoor unit main PCB for refrigerant system

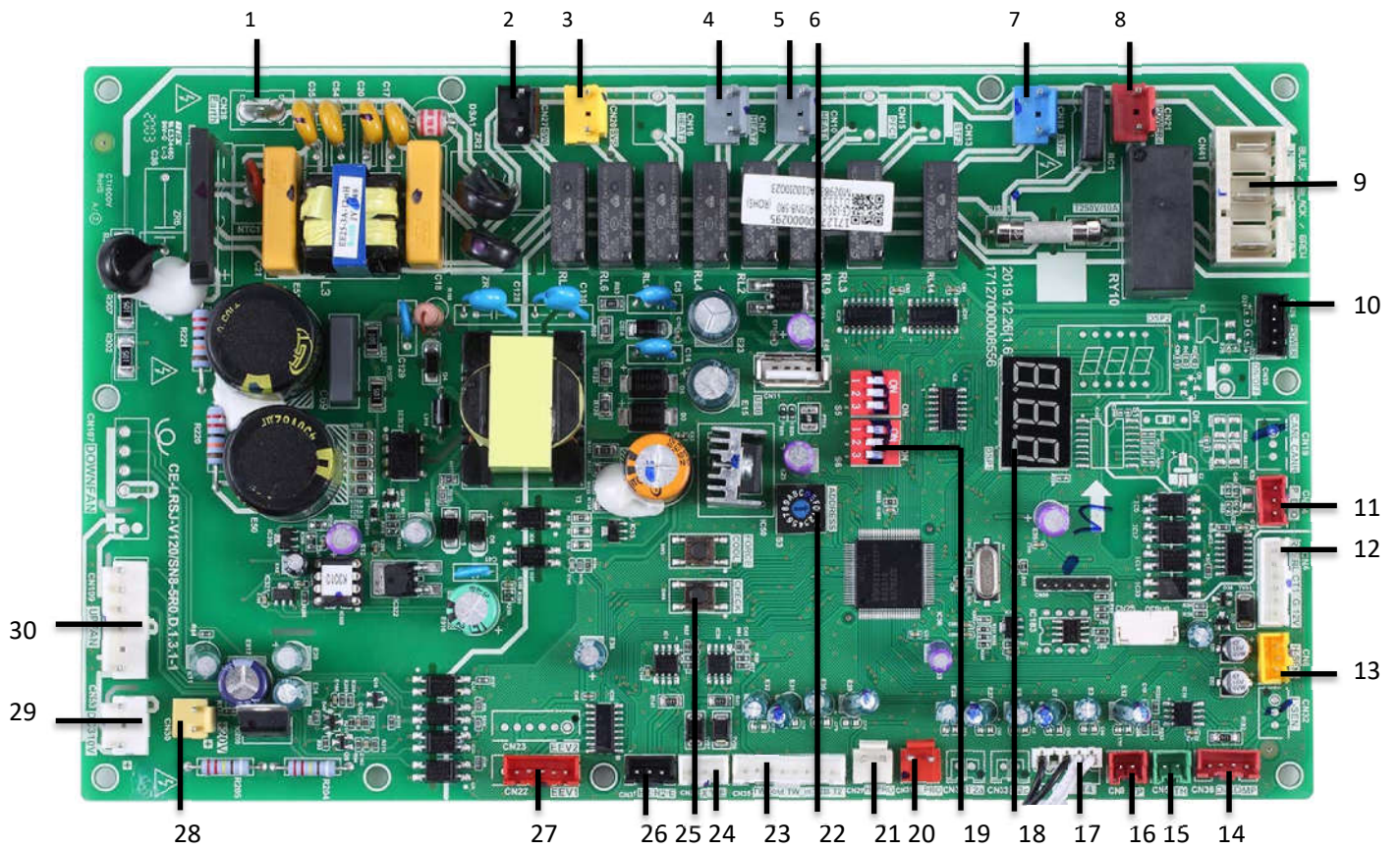

*Table 4-2.3: MSH-120EB; MSH-140EB; MSH-160EB outdoor unit main PCB for refrigerant system*

Label in Figure 4-2.3	Code	Content
1	CN28	Output port L to main PCB for refrigerant system
2	CN22	Reserved
3	CN27	Output port N to main PCB for refrigerant system
4	CN3	Reserved
5	PE2	Port for ground wire
6	DSP1	Digital display
7	CN17	Port for communication with main PCB for refrigerant system
8	PE1	Port for ground wire
9	CN26	Reserved
10	CN10	Input port for neutral wire
11	CN11	Input port for live wire
12	CN9	Port for outdoor ambient temp. sensor and condenser temp. sensor
13	CN24	Input port for +12V/9V
14	CN1	Port for suction temp. sensor
15	CN8	Port for discharge temp. sensor
16	CN13	Port for high pressure switch
17	CN14	Port for low pressure switch
18	CN29	Port for communication with hydro-box control board
19	CN4	Port for pressure sensor
20	CN30	Port for communication(reserved)
21	CN2	Port for communication(reserved)
22	CN33	Port for electrical expansion valve
23	CN16	Port for chassis electrical heating tape(Optional)
24	CN6	Port for 4-way valve
25	CN5	Port for SV6 valve
26	CN7	Port for compressor electric heating tape 1
27	CN18	Port for compressor electric heating tape 2

# S-Therm Yukon split series

Figure 4-2.4 MSH-120EB-3; MSH-140EB-3; MSH-160EB-3 outdoor unit main PCB for refrigerant system

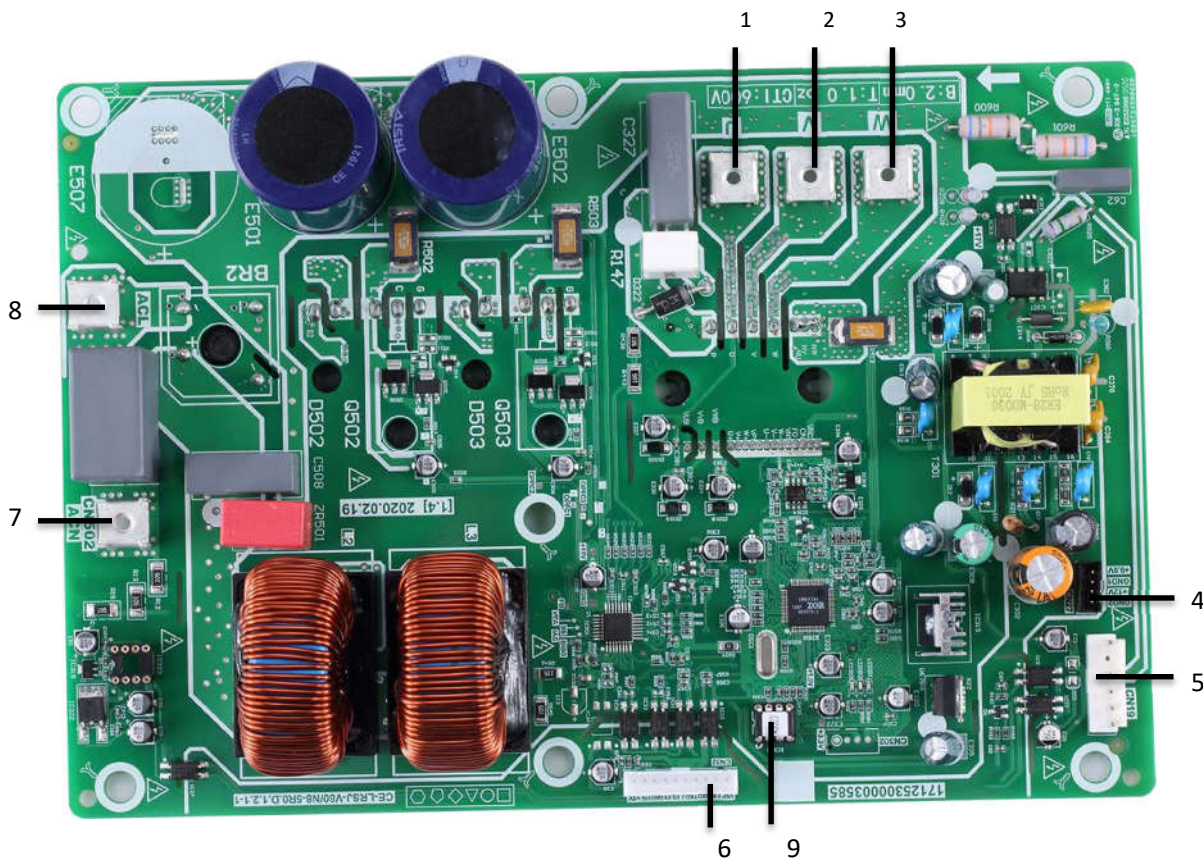

*Table 4-2.4: MSH-120EB-3; MSH-140EB-3; MSH-160EB-3 outdoor unit main PCB for refrigerant system*

Label in Figure 4-2.4	Code	Content
1	CN38	Port for GND
2	CN27	Port for 2-way valve 6
3	CN20	Port for 2-way valve 5
4	CN7	Port for electric heating tape2
5	CN10	Port for electric heating tape1
6	CN11	Reserved
7	CN18	Port for 4-way value
8	CN21	Reserved
9	CN41	Power supply port from main PCB for invert module board
10	CN26	Port for communication with Power Meter
11	CN24	Port for communication with hydro-box control board
12	CN4	Port for communication with main PCB for invert module board
13	CN6	Port for pressure sensor
14	CN36	Port for communication with main PCB for refrigerant system
15	CN5	Port for temp. sensor Th
16	CN8	Port for temp. sensor Tp
17	CN9	Port for outdoor ambient temp. sensor and condenser temp. sensor
18	DSP1	Digital display(DSP1)
19	S5,S6	DIP switch(S5,S6)
20	CN31	Port for low pressure switch(CN31)
21	CN29	Port for high pressure switch and quick check(CN29)
22	S3	Rotary dip switch(S3)
23	CN35	Port for temp. sensors(TW_out, TW_in, T1, T2,T2B )
24	CN28	Port for communication XYE
25	S3, S4	Key for fore cool & check
26	CN37	Port for communication H1H2E
27	CN22	Port for electrical expansion valve
28	CN30	Port for fan 15VDC power supply
29	CN53	Port for fan 310VDC power supply
30	CN109	Port for fan

Figure 4-2.5 MSH-60EB; MSH-80EB; MSH-100EB outdoor unit inverter module

For 4/6kW model



For 8/10kW model

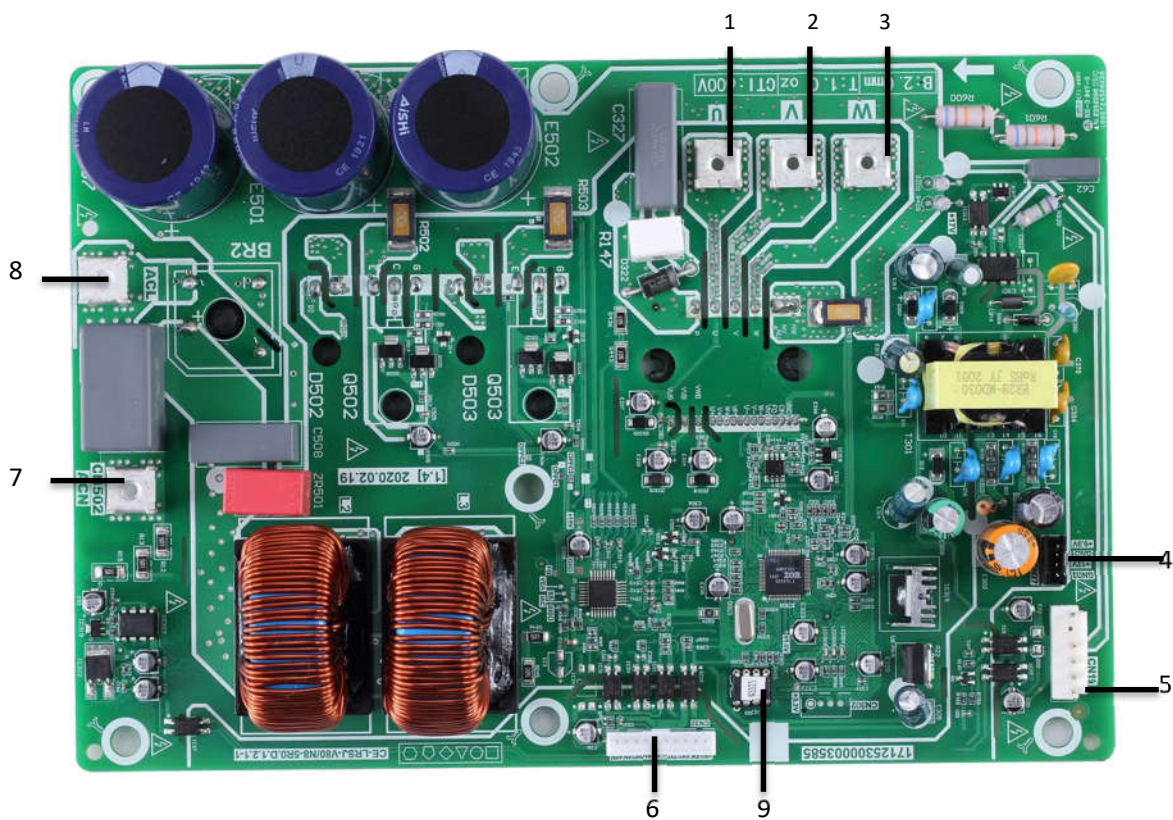

<i>Table 4-2.5: MSH-60EB; MSH-80EB; MSH-100EB outdoor unit inverter module</i>		
<b>Label in Figure 4-2.5</b>	<b>Code</b>	<b>Content</b>
1	U	Compressor connection port U
2	V	Compressor connection port V
3	W	Compressor connection port W
4	CN20	Output port for +12V/9V
5	CN19	Port for fan
6	CN32	Port for communication with main PCB for filter board
7	CN502	Input port N for rectifier bridge
8	CN501	Input port L for rectifier bridge
9	IC320	EEPROM

# S-Therm Yukon split series



Figure 4-2.6: MSH-120EB; MSH-140EB; MSH-160EB outdoor unit inverter module

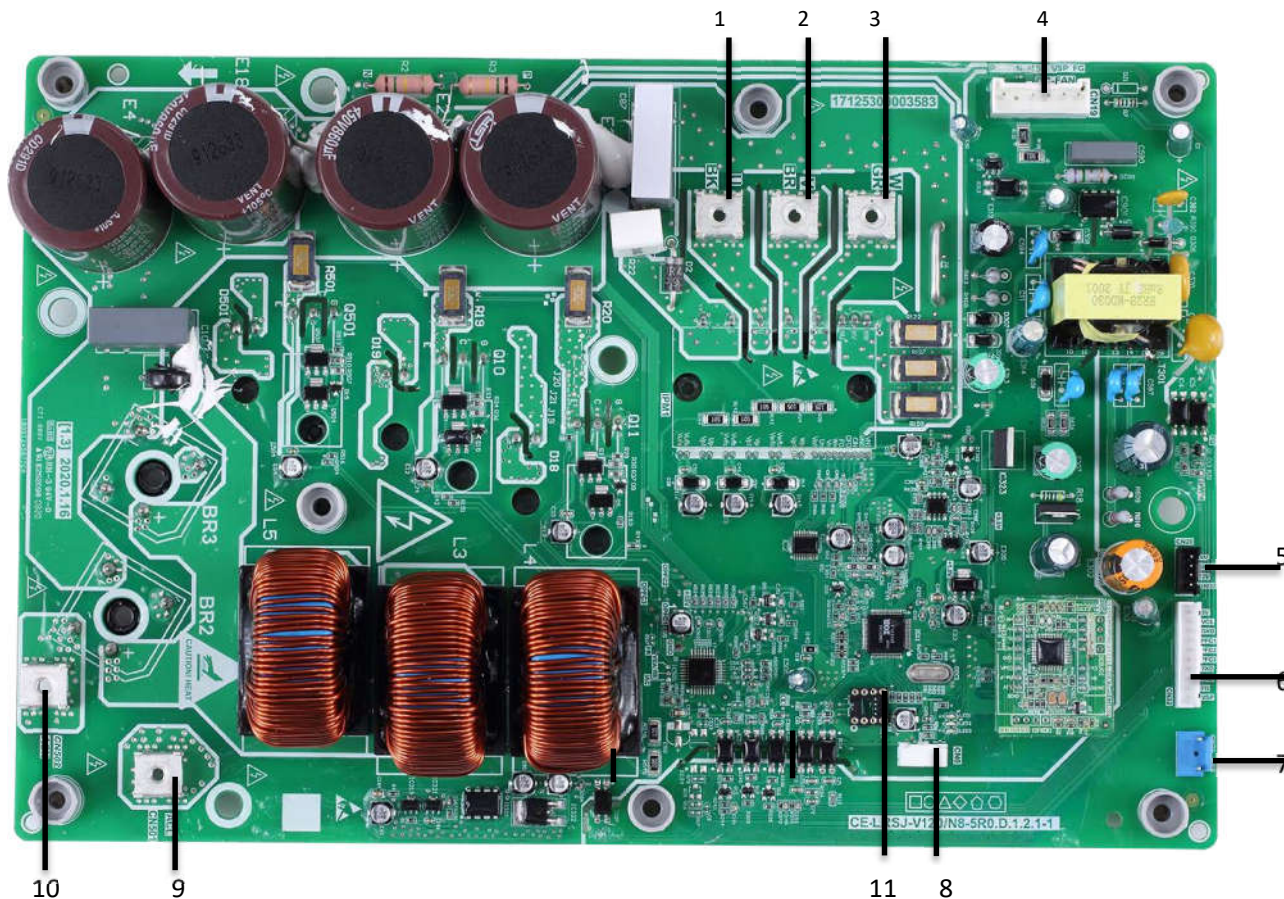

Table 4-2.6: MSH-120EB; MSH-140EB; MSH-160EB outdoor unit inverter module

Label in Figure 4-2.6	Code	Content
1	U	Compressor connection port U
2	V	Compressor connection port V
3	W	Compressor connection port W
4	CN19	Port for fan
5	CN20	Output port for +12V/9V
6	CN32	Port for communication with main PCB for filter board
7	CN23	Port for high pressure switch
8	CN6	Reserved
9	CN501	Input port L for rectifier bridge
10	CN502	Input port N for rectifier bridge
11	IC14	EEPROM

Figure 4-2.7: MSH-120EB-3; MSH-140EB-3; MSH-160EB-3 outdoor unit inverter module

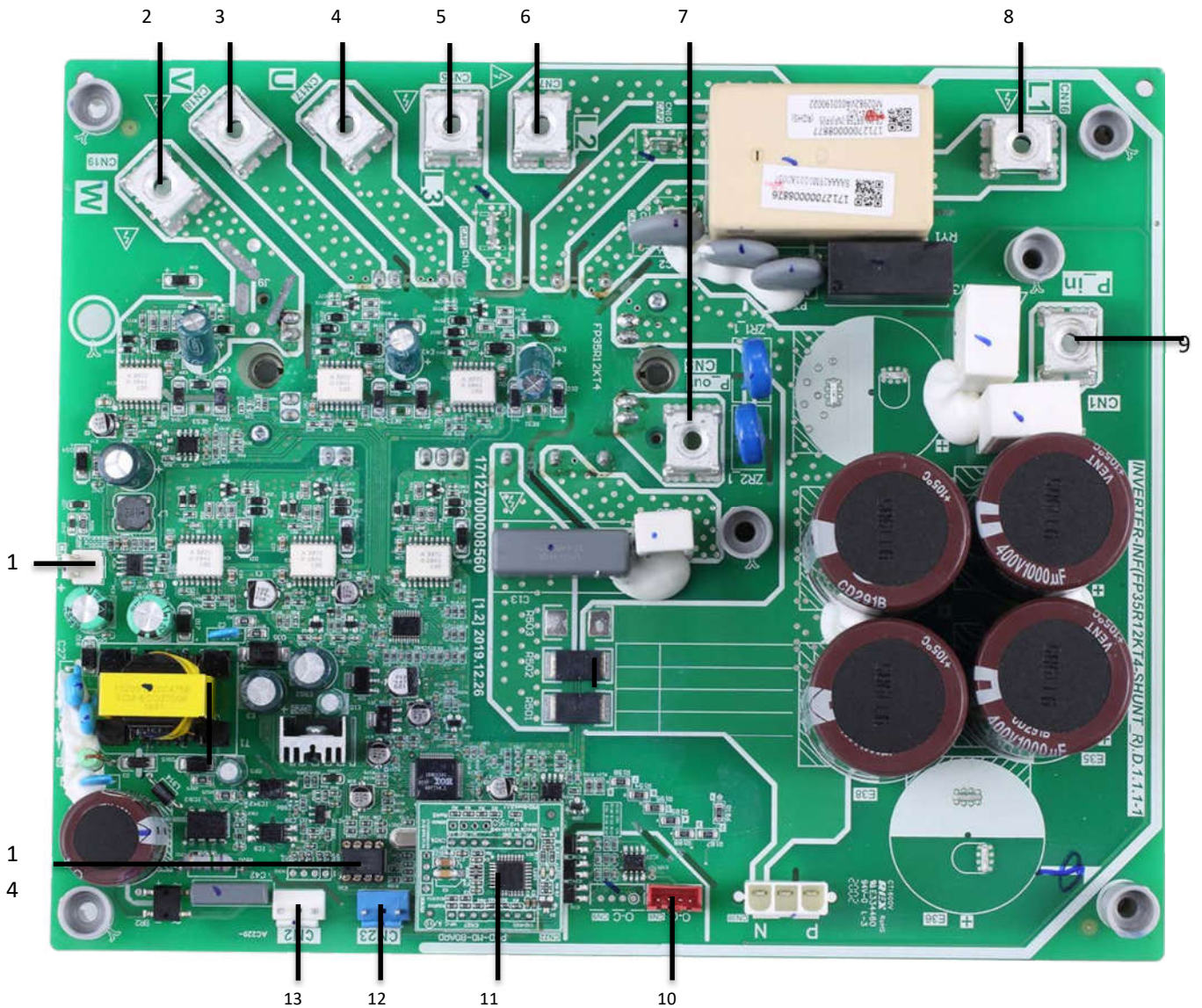

Table 4-2.7: MSH-120EB-3; MSH-140EB-3; MSH-160EB-3 outdoor unit inverter module

Label in Figure 4-2.7	Code	Content
1	CN20	Output port for +15V
2	CN19	Compressor connection port W
3	CN18	Compressor connection port V
4	CN17	Compressor connection port U
5	CN15	Power Input port L3
6	CN7	Power Input port L2
7	CN5	Input port P_out for IPM module
8	CN16	Power Input port L1
9	CN1	Input port P_in for IPM module
10	CN8	Port for communication with main PCB for filter board
11	CN22	PED board
12	CN23	Power for high pressure switch
13	CN2	Port for communication with PCB
14	IC25	EEPROM

Figure 4-2.8: MSH-120EB-3; MSH-140EB-3; MSH-160EB-3 outdoor unit filter board

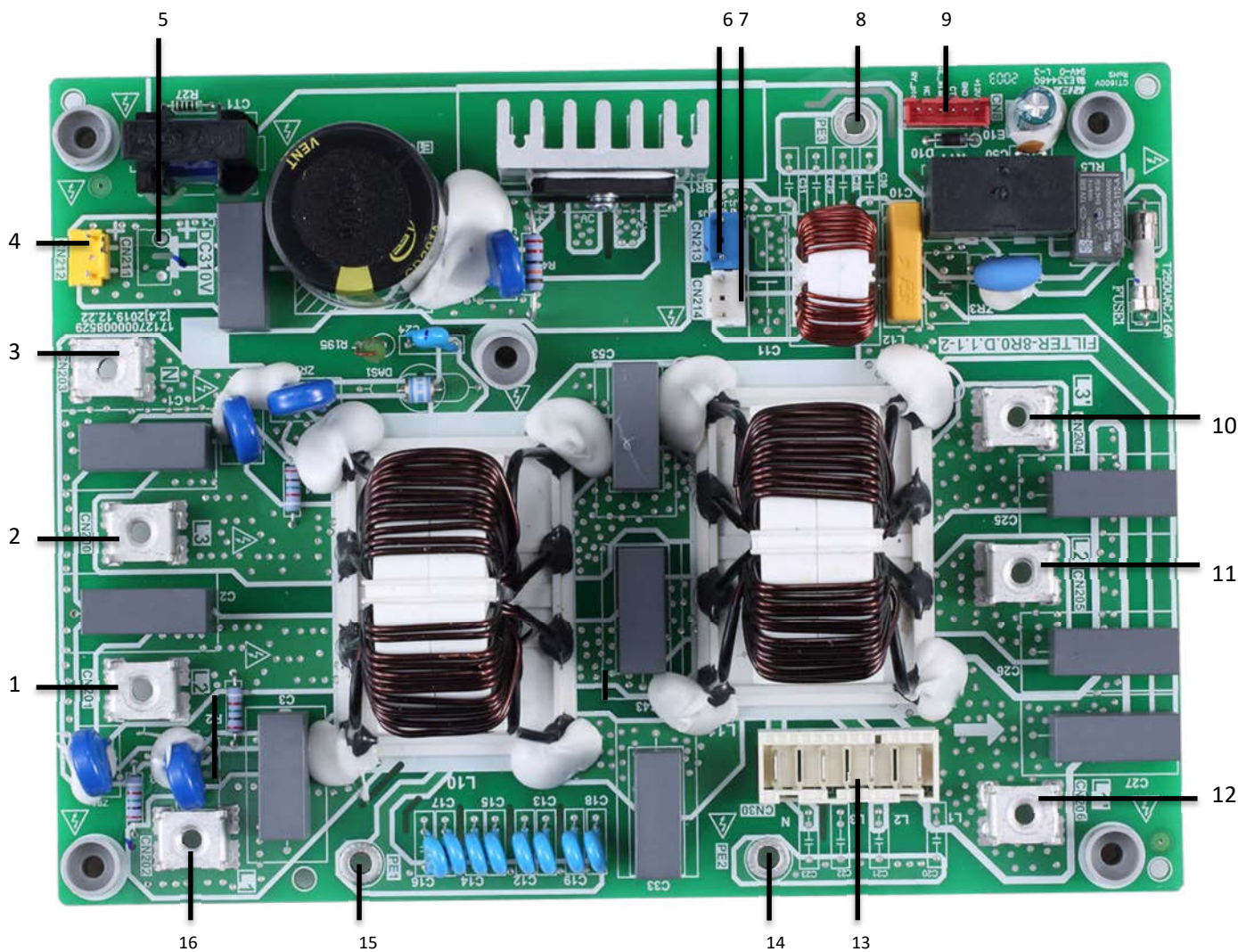

Table 4-2.8: MSH-120EB-3; MSH-140EB-3; MSH-160EB-3 outdoor unit filter board

Label in Figure 4-2.8	Code	Content
1	CN201	Power supply L2
2	CN200	Power supply L3
3	CN203	Power supply N
4	CN212	Power supply port of 310VDC
5	CN211	Reserved
6	CN213	Port for FAN Reactor
7	CN214	Power supply port for Inverter module
8	PE3	Ground wire
9	CN8	Port for communication with main PCB for filter board
10	L3'	Power filtering L3
11	L2'	Power filtering L2
12	L1'	Power filtering L1
13	CN30	Power supply port for main control board

14	PE2	Port for ground wire
15	PE1	Port for ground wire
16	L1	Power supply L1

## 2.4 Digital Display Output

Table 4-2.9: Digital display output in different operating states

S-Therm Yukon system state	Parameters displayed on outdoor	Parameters displayed on hydronic
	unit main PCB DSP1	box main PCB DSP1
On standby	0	0
Normal operation	Running speed of the compressor in rotations per second	Leaving water temperature (°C)
Error or protection	Error or protection code	Error or protection code

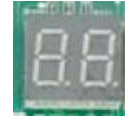

## 2.5 DIP switch setting and Modbus function (Modbus function will be available in 2020-5-30)

The rotating coded switch S3(0-F) on the main control board of hydraulic module is used for setting the modbus address. By default the units have this coded switch positioned=0, but this corresponds to the modbus address 16, while the others positions corresponds the number, e.g. pos=2 is address 2, pos=5 is address 5.

Figure 4-2.10: Rotating switch



Figure 4-2.11: Connection

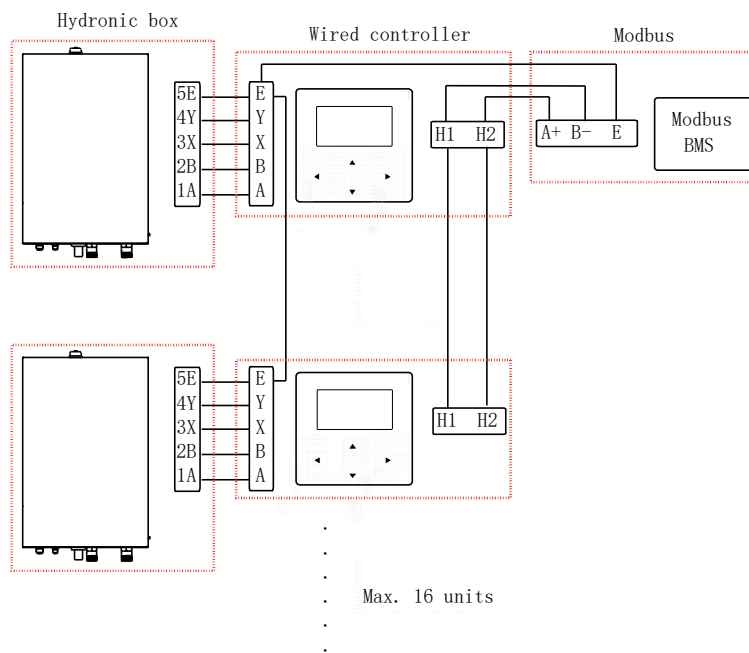

Note: Wired controller is integrated in the hydronic box.

## S-Therm Yukon split series

Figure 4-2.12: Wiring

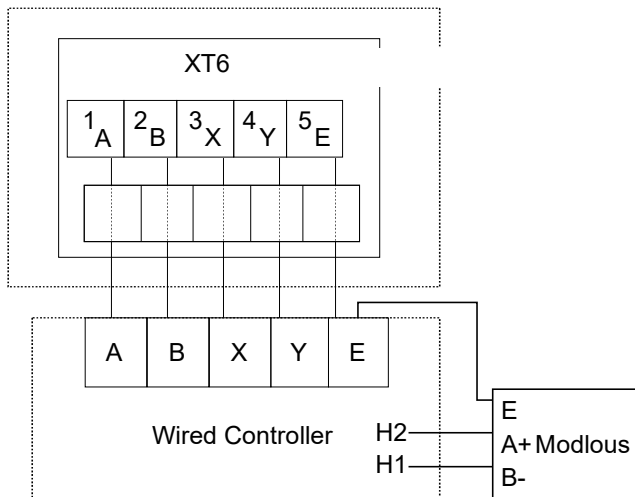

Input Voltage(A/B)	13.5VAC
Wiring size	0.75mm <sup>2</sup>

### 3 Error Code Table

Table 4-3.1: Error code table

Error code	Serial Number <sup>1</sup>	Content <sup>2</sup>	Remarks
C7	65	High temperature protection of transducer module	
E0	1	Water flow failure(E8 appears for 3 times)	
E1	2	Phase sequence error	Only applies to 3-phase models
E2	3	Communication error between the main control board of hydraulic module and user interface	
E3	4	Final outlet water temperature sensor error	Sensor T1
E4	5	Domestic hot water tank temperature sensor error	Sensor T5
E5	6	Air side heat exchanger refrigerant outlet temperature sensor error	Sensor T3
E6	7	Outdoor ambient temperature sensor error	Sensor T4
E7	8	Balance tank upper temperature sensor error	Sensor Tbt1
E8	9	Water flow failure	
E9	10	Suction pipe temperature sensor error	Sensor Th
EA	11	Discharge pipe temperature sensor error	Sensor Tp
Eb	12	Solar panel temperature sensor error	Sensor Tsolar
Ec	13	Balance tank nether temperature sensor error	Sensor Tbt2
Ed	14	Water side heat exchanger water inlet temperature sensor error	Sensor Tw_in
EE	15	Hydronic box EEPROM error	
F1	116	DC generatrix voltage is too low	
H0	39	Communication error between outdoor unit main control chip and hydronic box main control chip	
H1	40	Communication error between outdoor unit main control chip and inverter driver chip	
H2	41	Water side heat exchanger refrigerant outlet (liquid pipe) temperature sensor error	Sensor T2
H3	42	Water side heat exchanger refrigerant inlet (gas pipe) temperature sensor error	Sensor T2B
H4	43	P6 appear 3 times in one hour	
H5	44	Room temperature sensor error	Sensor Ta

H6,	45	DC fan error	
H7	46	Abnormal main circuit voltage	
H8	47	Pressure sensor error	
H9	48	Circuit 2 water outlet temperature sensor error	Sensor Tw2
HA	49	Water side heat exchanger water outlet temperature sensor error	Sensor Tw_out
Hb	50	PP protection appears three times in a row and Twout<7°C	
HF	54	Invert module EEPROM error	
HH	55	DC fan error(H6 appears 10 times in 120min)	
HP	57	Low pressure protection for cooling mode	
P0	20	Low pressure switch protection	
P1	21	High pressure switch protection	
P3	23	Compressor current protection	
P4	24	Discharge temperature protection	
P5	25	High temperature difference between water side heat exchanger water inlet and water outlet temperatures protection	
P6	26	Inverter module protection	
L0	-	Inverter module protection	
L1	-	DC bus low voltage protection	
L2	-	DC bus high voltage protection	
L4	-	MCE error	
L5	-	Zero speed protection	
L7	-	Phase sequence error	
L8	-	Compressor frequency variation greater than 15Hz within one second protection	
L9	-	Actual compressor frequency differs from target frequency by more than 15Hz protection	
Pb	31	Water side heat exchanger anti-freeze protection	
Pd	33	High temperature protection of refrigerant outlet temperature of condenser in cooling mode	
PP	38	Water side heat exchanger inlet temperature is higher than outlet temperature in heating mode or DHW mode	
bH	112	PED board error	

**Notes:**

1. When the error code appears, the error code corresponding to the serial number can be obtained through the H1H2 port by using the host computer to query the wired controller register.
2. Sensor names in this service manual referring to refrigerant flow is named according refrigerant flow during cooling operation refer to Part 2, 3 "Refrigerant Flow Diagrams".

### 4 Troubleshooting

#### 4.1 Warning

##### Warning



- All electrical work must be carried out by competent and suitably qualified, certified and accredited professionals and in accordance with all applicable legislation (all national, local and other laws, standards, codes, rules, regulations and other legislation that apply in a given situation).
- Power-off the outdoor units before connecting or disconnecting any connections or wiring, otherwise electric shock (which can cause physical injury or death) may occur or damage to components may occur.

## 4.2 E0, E8 Troubleshooting

### 4.2.1 Digital display output

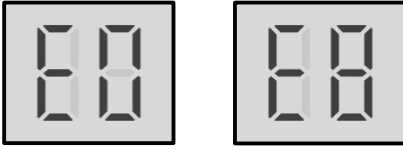

### 4.2.2 Description

- Water flow failure.
- E0 indicates E8 has displayed 3 times. When an E0 error occurs, a manual system restart is required before the system can resume operation.
- S-Therm Yukon stops running.
- Error code is displayed on hydronic box main PCB and user interface.

### 4.2.3 Possible causes

- The wire circuit is short connected or open.
- Water flow rate is too low.
- Water flow switch damaged.

# S-Therm Yukon split series



## 4.2.4 Procedure

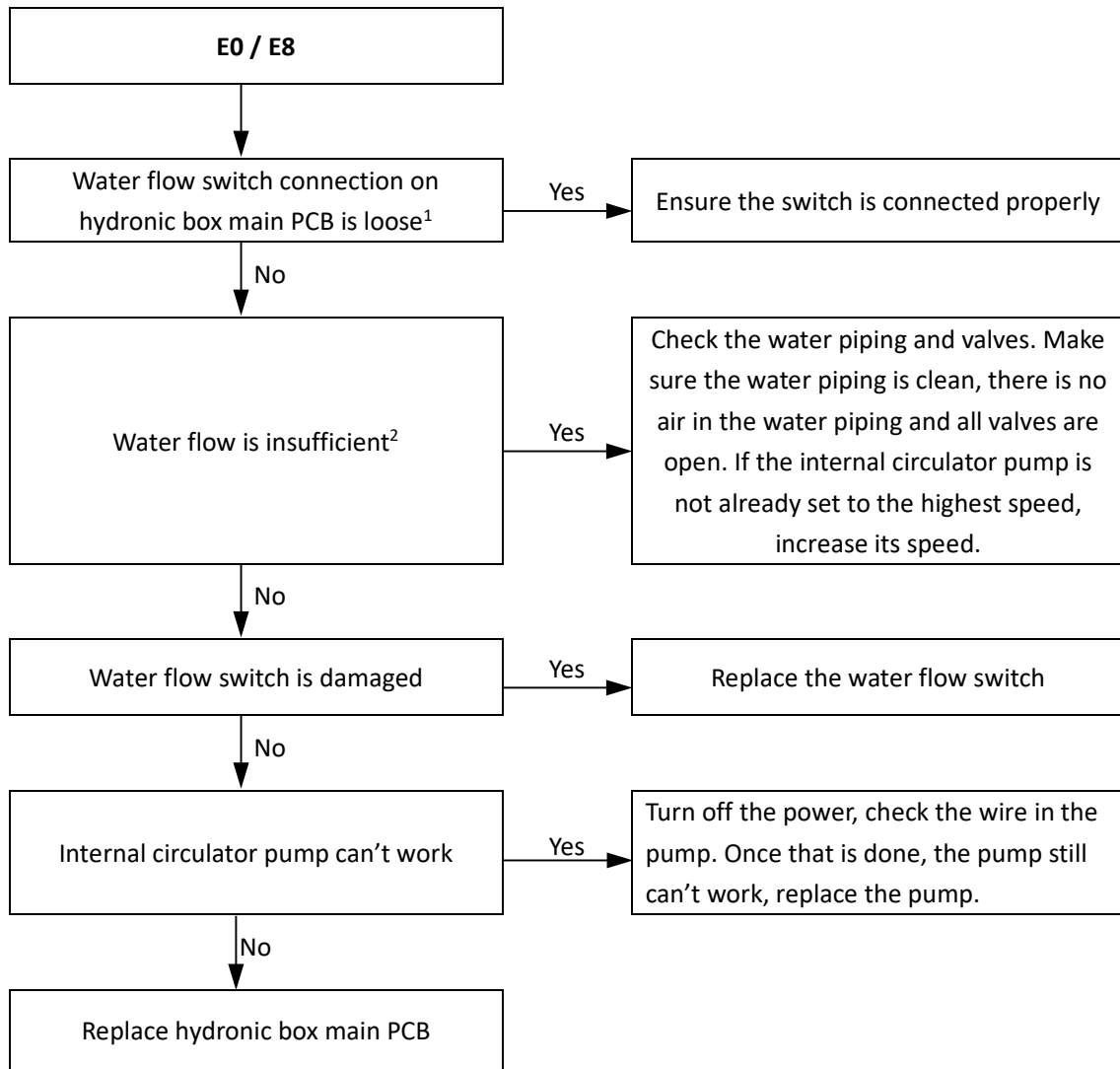

Notes:

1. Water flow switch connection is port CN8 on the main PCB for hydronic box (labeled 9 in Figure 4-2.1 in Part4, 2.2 "Main PCB for Hydronic System").
2. Check water pressure on the manometer. If the water pressure is not > 1 bar, water flow is insufficient. Refer to Figure 2-1.9 in Part 2, 1 "Hydronic Box Layout".

### 4.3 E1 Troubleshooting

#### 4.3.1 Digital display output



#### 4.3.2 Description

- Phase sequence error.
- Only applies to 3-phase models.
- S-Therm Yukon stops running.
- Error code is displayed on outdoor unit main PCB and user interface.

#### 4.3.3 Possible causes

- Power supply phases not connected in correct sequence.
- Power supply terminals loose.
- Power supply abnormal.
- Main PCB damaged.

# S-Therm Yukon split series



## 4.3.4 Procedure

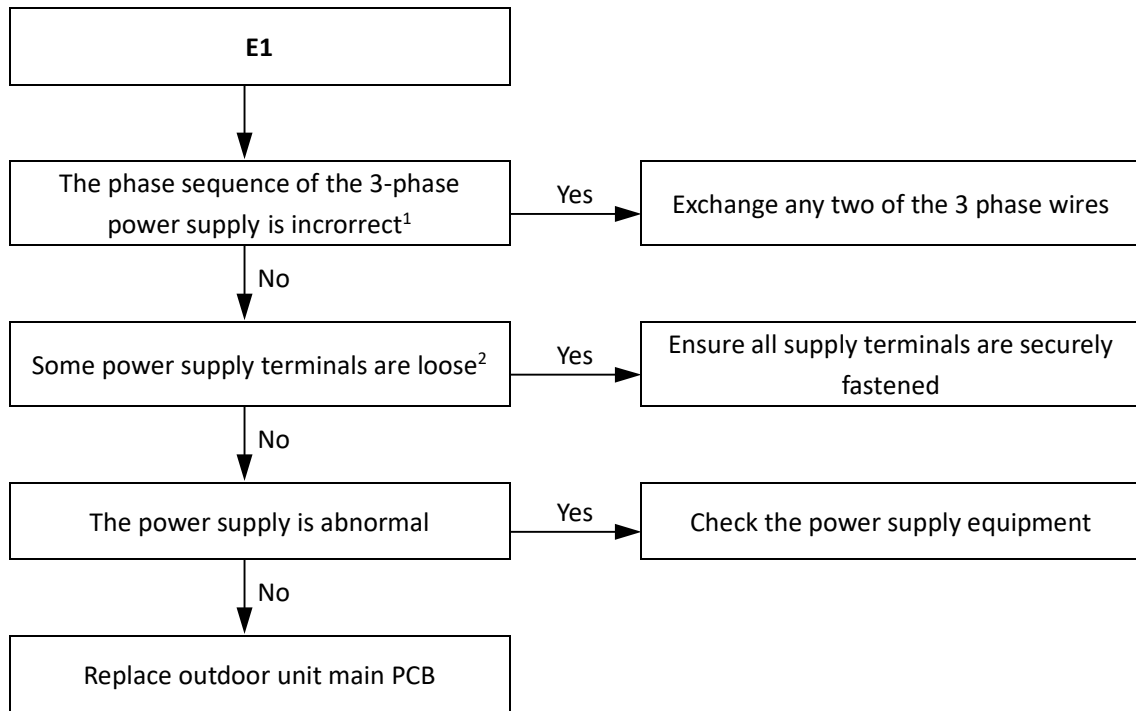

Notes:

1. The A, B, C terminals of 3-phase power supply should match compressor phase sequence requirements. If the phase sequence is inverted, the compressor will operate inversely. If the wiring connection of each outdoor unit is in A, B, C phase sequence, and multiple units are connected, the current difference between C phase and A, B phases will be very large as the power supply load of each outdoor unit will be on C phase. This can easily lead to tripped circuits and terminal wiring burnout. Therefore if multiple units are to be used, the phase sequence should be staggered, so that the current is distributed among the three phases equally.
2. Loose power supply terminals can cause the compressors to operate abnormally and compressor current to be very large.

**4.4 E2 Troubleshooting****4.4.1 Digital display output****4.4.2 Description**

- Communication error between hydronic box and user interface.
- S-Therm Yukon stops running.
- Error code is displayed on hydronic box main PCB and user interface.

**4.4.3 Possible causes**

- Communication wires between hydronic box and user interface not connected properly.
- Communication wiring X Y E terminals misconnected.
- Loosened wiring within electric control box.
- Interference from high voltage wires or other sources of electromagnetic radiation.
- Damaged main PCB or electric control box communication terminals block.

# S-Therm Yukon split series



## 4.4.4 Procedure

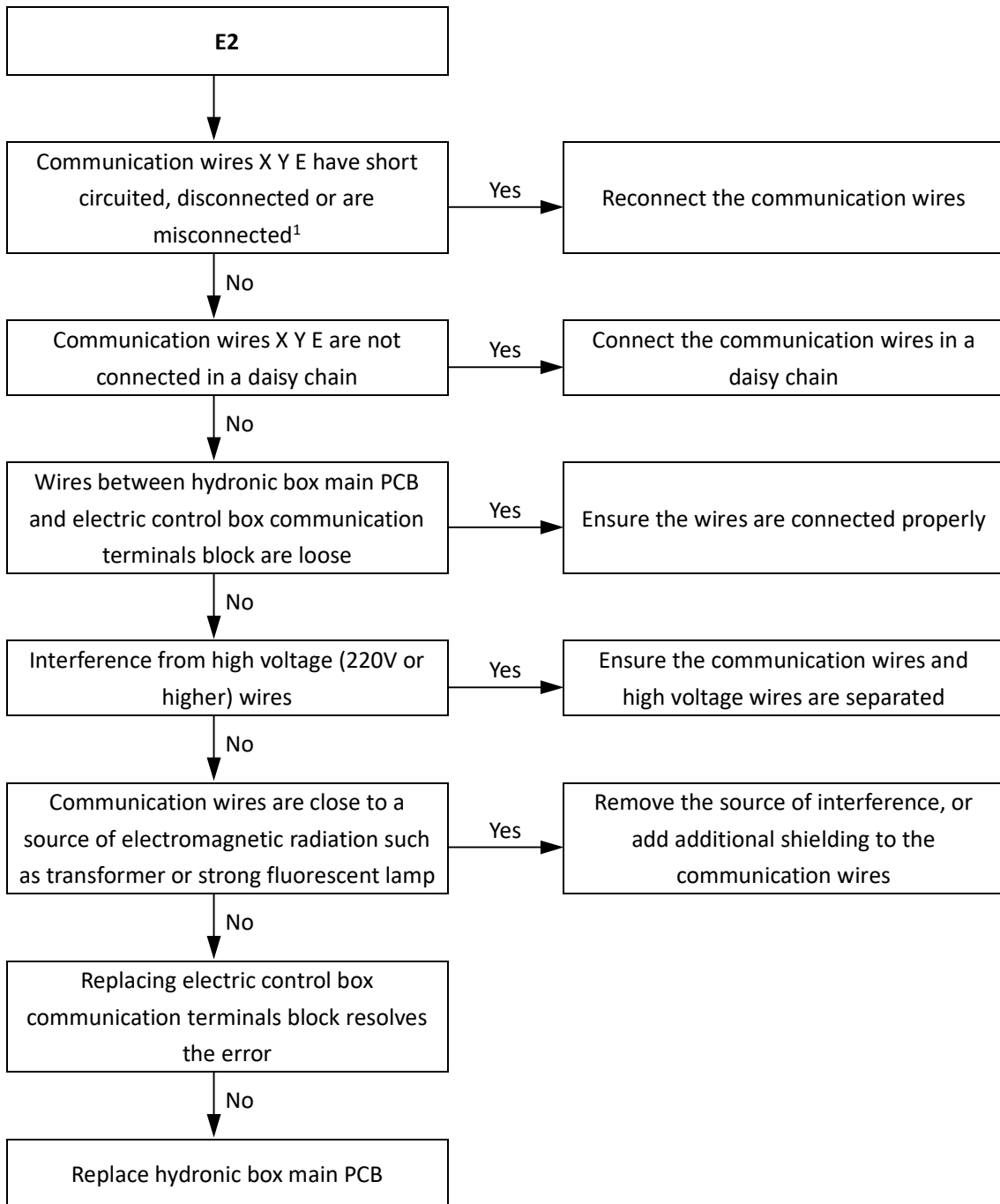

Notes:

1. Measure the resistance among X, Y and E. The normal resistance between P and Q is 120Ω, between P and E is infinite, between Y and E is infinite. Communication wiring has polarity. Ensure that the X wire is connected to X terminals and the Y wire is connected to Y terminals.

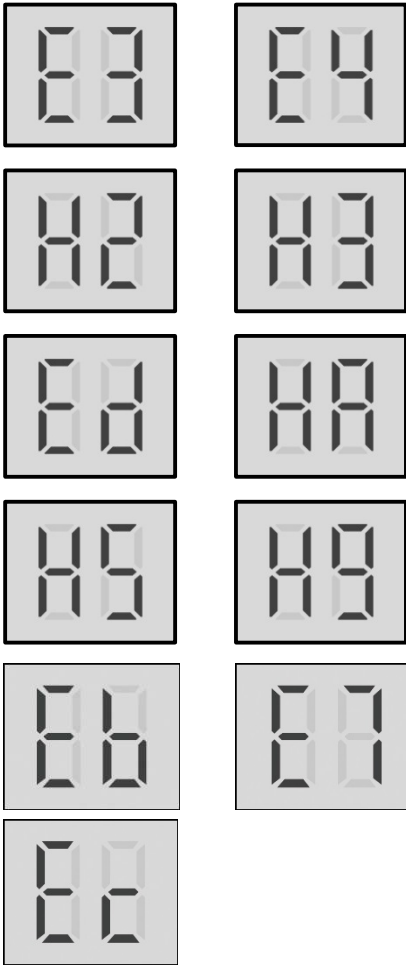
**4.5 E3, E4, H2, H3, Ed, HA, H5, H9, Eb, E7, Ec Troubleshooting**
**4.5.1 Digital display output**

**4.5.2 Description**

- E3 indicates final outlet water temperature sensor error
- E4 indicates a domestic hot water tank temperature sensor error.
- H2 indicates a water side heat exchanger refrigerant outlet (liquid pipe) temperature sensor error.
- H3 indicates a water side heat exchanger refrigerant inlet (gas pipe) temperature sensor error.
- Ed indicates a water side heat exchanger water inlet temperature sensor error.
- HA indicates a water side heat exchanger water outlet temperature sensor error.
- H5 indicates a room temperature sensor error.
- H9 indicates a circuit 2 water outlet temperature sensor error.
- Eb indicates solar panel temperature sensor error
- E7 indicates balance tank upper temperature sensor error
- Ec indicates balance tank nether temperature sensor error
- S-Therm Yukon stops running.
- Error code is displayed on hydronic box main PCB and user interface.

**4.5.3 Possible causes**

- Temperature sensor not connected properly or has malfunctioned.
- Damaged hydronic box main PCB.

# S-Therm Yukon split series



## 4.5.4 Procedure

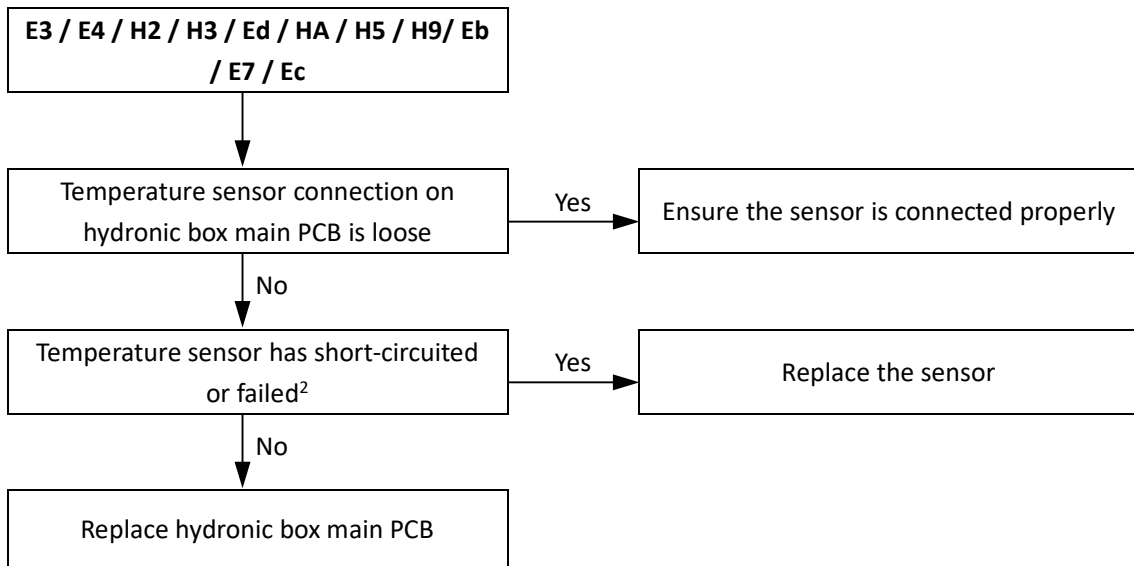

### Notes:

1. Final water outlet temperature sensor, water side heat exchanger refrigerant inlet (liquid pipe) temperature sensor, water side heat exchanger refrigerant outlet (gas pipe) temperature sensor, water side heat exchanger water inlet temperature sensor and water side heat exchanger water outlet temperature sensor connections are port CN6 on the hydronic box main PCB (labeled 10 in Figure 4-2.1 in Part4, 2.2 "Main PCB for Hydronic System"). Domestic hot water tank temperature sensor connection is port CN13 on the hydronic box main PCB (labeled 13 in Figure 4-2.1 in Part4, 2.2 "Main PCB for Hydronic System"). Circuit 2 water outlet temperature sensor connection is port CN15 on the hydronic box main PCB (labeled 14 in Figure 4-2.1 in Part4, 2.2 "Main PCB for Hydronic System"). Room temperature sensor connection is port CN11 on the hydronic box main PCB (labeled 24 in Figure 4-2.1 in Part4, 2.2 "Main PCB for Hydronic System"). Solar panel temperature sensor connection is port CN18 on the hydronic box main PCB (labeled 15 in Figure 4-2.1 in Part4, 2.2 "Main PCB for Hydronic System"). Balance tank upper temperature sensor connection is port CN24 on the hydronic box main PCB (labeled 11 in Figure 4-2.1 in Part4, 2.2 "Main PCB for Hydronic System") Balance tank nether temperature sensor connection is port CN16 on the hydronic box main PCB (labeled 12 in Figure 4-2.1 in Part4, 2.2 "Main PCB for Hydronic System")
2. Measure sensor resistance. If the resistance is too low, the sensor has short-circuited. If the resistance is not consistent with the sensor's resistance characteristics table, the sensor has failed. Refer to Table 4-5.1 or 4-5.3 in Part 4, 5.1 "Temperature Sensor Resistance Characteristics".

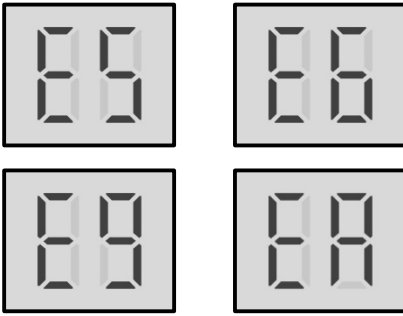
**4.6 E5, E6, E9, EA Troubleshooting****4.6.1 Digital display output****4.6.2 Description**

- E5 indicates an air side heat exchanger refrigerant outlet temperature sensor error.
- E6 indicates an outdoor ambient temperature sensor error.
- E9 indicates a suction pipe temperature sensor error.
- EA indicates a discharge temperature sensor error.
- S-Therm Yukon stops running.
- Error code is displayed on outdoor unit main PCB and user interface.

**4.6.3 Possible causes**

- Temperature sensor not connected properly or has malfunctioned.
- Damaged outdoor unit main PCB.

# S-Therm Yukon split series



## 4.6.4 Procedure

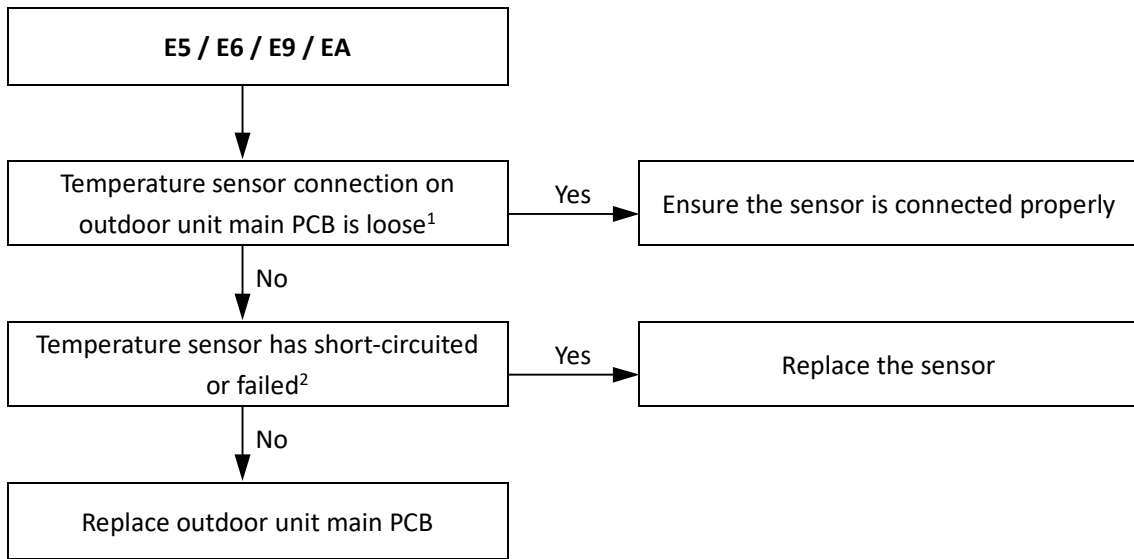

### Notes:

1. Air side heat exchanger refrigerant outlet temperature sensor and outdoor ambient temperature sensor connections are port CN9 on the MSH-60EB; MSH-80EB; MSH-100EB outdoor unit refrigerant system main PCB (labeled 12 in Figure 4-2.2 in Part 4, 2.1 “Main PCBs for Refrigerant System, Inverter Module”), port CN9 on the MSH-120EB; MSH-140EB; MSH-160EB outdoor unit refrigerant system main PCB (labeled 12 in Figure 4-2.3 in Part 4, 2.1 “Main PCBs for Refrigerant System, Inverter Module”), port CN9 on the MSH-120EB-3; MSH-140EB-3; MSH-160EB-3 outdoor unit refrigerant system main PCB (labeled 17 in Figure 4-2.4 in Part 4, 2.1 “Main PCBs for Refrigerant System, Inverter Module”). Discharge pipe temperature sensor connection are port CN8 on the MSH-60EB; MSH-80EB; MSH-100EB outdoor unit refrigerant system main PCB (labeled 15 in Figure 4-2.2 in Part 4, 2.1 “Main PCBs for Refrigerant System, Inverter Module”), port CN8 on the MSH-120EB; MSH-140EB; MSH-160EB outdoor unit refrigerant system main PCB (labeled 15 in Figure 4-2.3 in Part 4, 2.1 “Main PCBs for Refrigerant System, Inverter Module”), port CN4 on the MSH-120EB-3; MSH-140EB-3; MSH-160EB-3 outdoor unit refrigerant system main PCB (labeled 15 in Figure 4-2.4 in Part 4, 2.1 “Main PCBs for Refrigerant System, Inverter Module”). Suction pipe temperature sensor connection are port CN1 on the MSH-60EB; MSH-80EB; MSH-100EB outdoor unit refrigerant system main PCB (labeled 14 in Figure 4-2.2 in Part 4, 2.1 “Main PCBs for Refrigerant System, Inverter Module”), port CN1 on the MSH-120EB; MSH-140EB; MSH-160EB outdoor unit refrigerant system main PCB (labeled 14 in Figure 4-2.3 in Part 4, 2.1 “Main PCBs for Refrigerant System, Inverter Module”), port CN8 on the MSH-120EB-3; MSH-140EB-3; MSH-160EB-3 outdoor unit refrigerant system main PCB (labeled 16 in Figure 4-2.4 in Part 4, 2.1 “Main PCBs for Refrigerant System, Inverter Module”).
2. Measure sensor resistance. If the resistance is too low, the sensor has short-circuited. If the resistance is not consistent with the sensor’s resistance characteristics table, the sensor has failed. Refer to Table 4-5.1, and Table 4-5.2 in Part 4, 5.1 “Temperature Sensor Resistance Characteristics”.

## 4.7 EE Troubleshooting

### 4.7.1 Digital display output



### 4.7.2 Description

- Hydronic box main PCB EEPROM error.
- S-Therm Yukon stops running.
- Error code is displayed on hydronic box main PCB and user interface.

### 4.7.3 Possible causes

- Hydronic box main PCB EEPROM is not connected properly.
- Hydronic box main PCB damaged.

### 4.7.4 Procedure

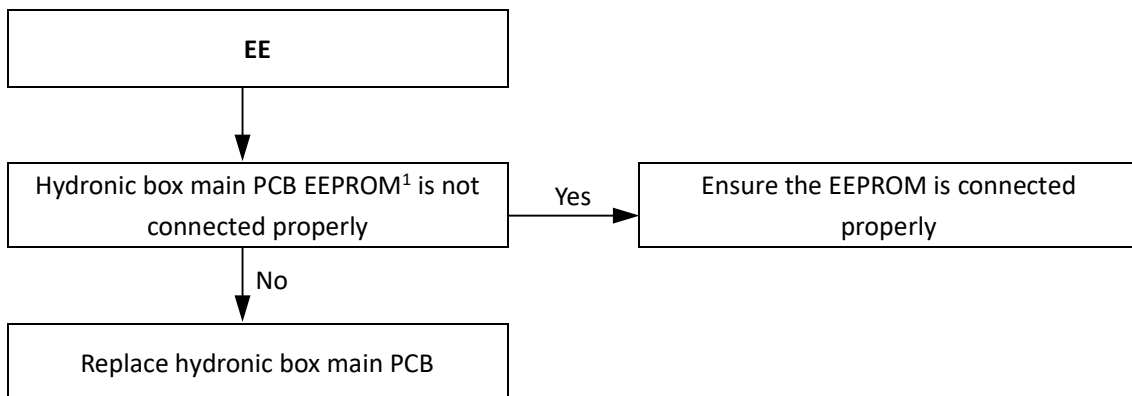

Notes:

1. Hydronic box main PCB EEPROM is designated IC39 on the main PCB for hydronic box (labeled 31 in Figure 4-2.1 in Part4, 2.2 "Main PCB for Hydronic System").

## S-Therm Yukon split series

### 4.8 F1 Troubleshooting

#### 4.8.1 Digital display output



#### 4.8.2 Description

- Low DC generatrix voltage.
- S-Therm Yukon stops running.
- Error code is displayed on hydronic system main PCB and user interface.

#### 4.8.3 Possible causes

- The DC generatrix voltage is too low.

#### 4.8.4 Procedure

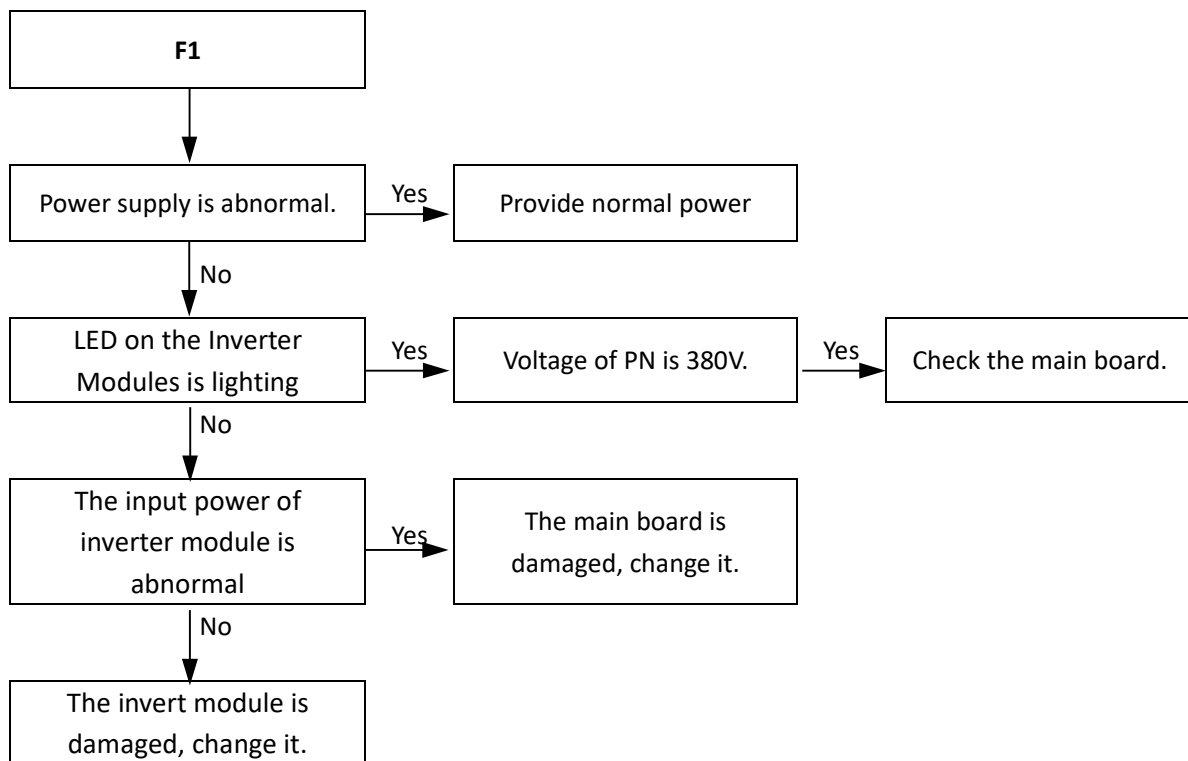

## 4.9 HF Troubleshooting

### 4.9.1 Digital display output



### 4.9.2 Description

- Outdoor unit inverter module EEPROM error.
- S-Therm Yukon stops running.
- Error code is displayed on outdoor unit main PCB and user interface.

### 4.9.3 Possible causes

- Outdoor unit invert module EEPROM is not connected properly.
- Outdoor unit invert module EEPROM damaged.

### 4.9.4 Procedure

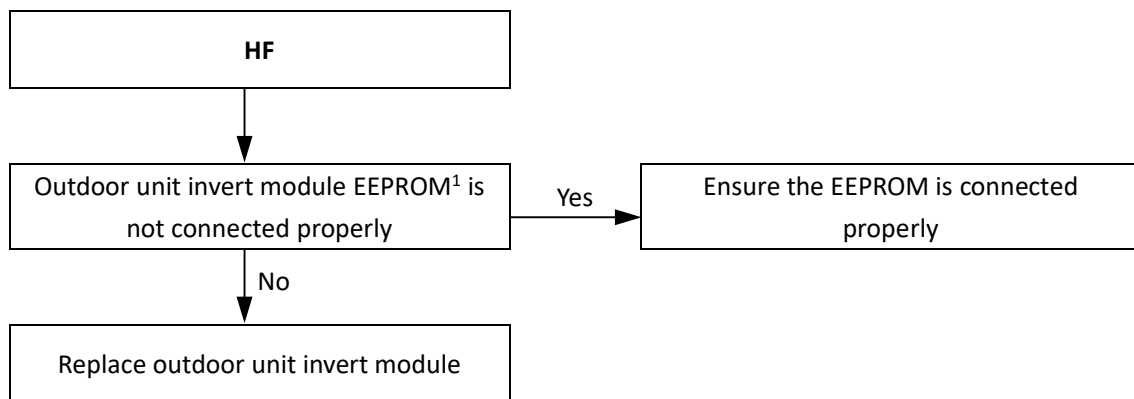

#### Notes:

1. Outdoor unit **invert module** EEPROM is designated IC320 on the MSH-60EB; MSH-80EB; MSH-100EB outdoor unit **invert module** (labeled 9 in Figure 4-2.5 in Part4, 2.3 "Main PCBs for Refrigerant System, Inverter Module"), designated IC14 on the MSH-120EB; MSH-140EB; MSH-160EB outdoor unit **invert module** (labeled 11 in Figure 4-2.6 in Part4, 2.3 "Main PCBs for Refrigerant System, Inverter Module"), designated IC25 on the MSH-120EB-3; MSH-140EB-3; MSH-160EB-3 outdoor unit **invert module** (labeled 14 in Figure 4-2.7 in Part4, 2.3 "Main PCBs for Refrigerant System, Inverter Module").

### 4.10 H0 Troubleshooting

#### 4.10.1 Digital display output



#### 4.10.2 Description

- Communication error between outdoor unit and hydronic box.
- S-Therm Yukon stops running.
- Error code is displayed on hydronic box main PCB, outdoor unit main PCB and user interface.

#### 4.10.3 Possible causes

- Power supply abnormal.
- Transformer malfunction.
- Interference from a source of electromagnetic radiation.
- Outdoor unit main PCB or hydronic box main PCB damaged.

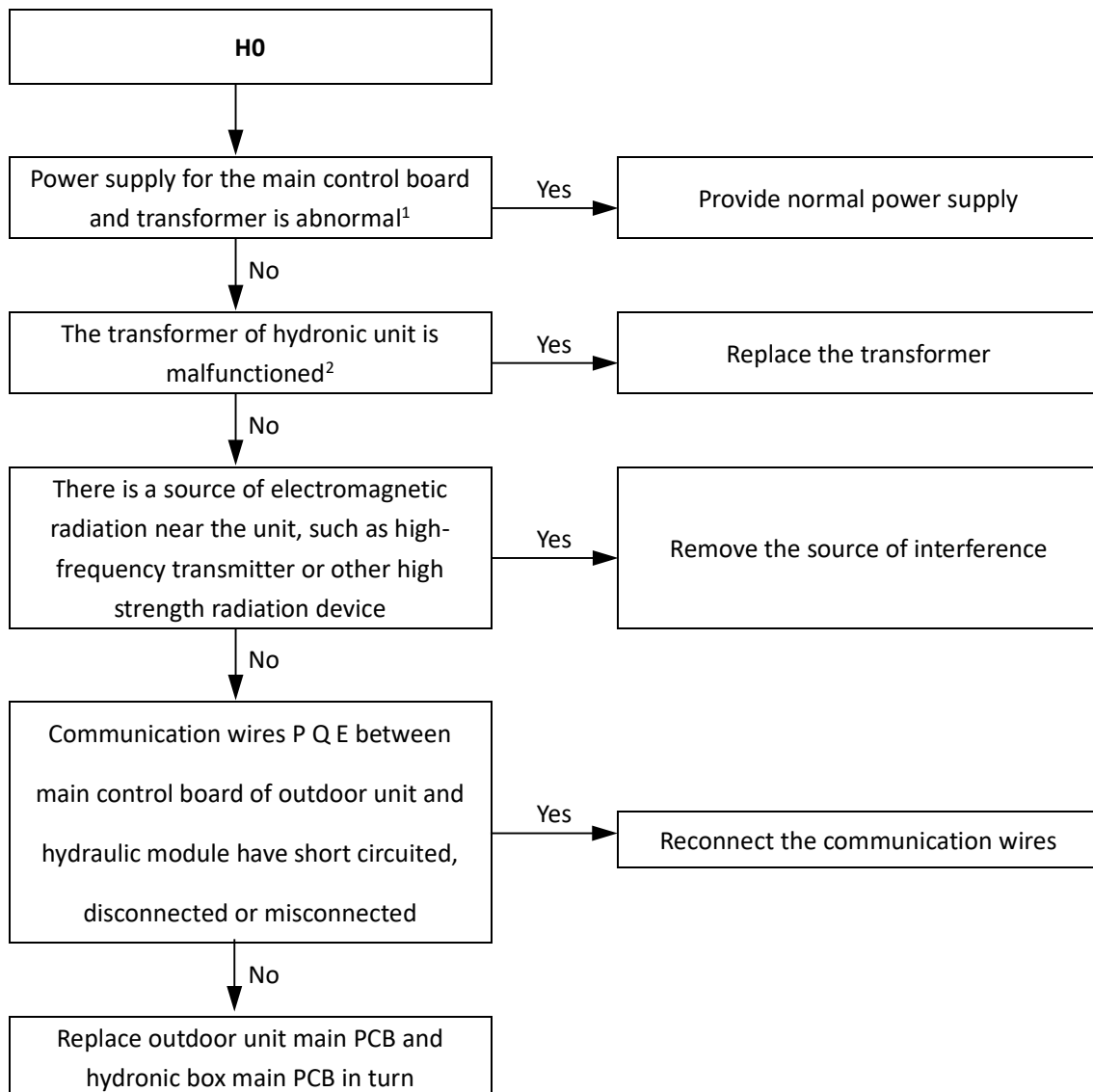
**4.10.4 Procedure**

**Notes:**

1. Measure the voltages of transformer input port and out port. The input voltage of transformer is 220V AC, output voltage of transformer is 13.5V AC. If any voltages is abnormal, the power supply for the main control board of hydraulic module and transformer will be abnormal.
2. Measure the voltages of transformer output port ports. If the voltages are not normal, the transformer has malfunctioned.

# S-Therm Yukon split series

## 4.11 H1 Troubleshooting

### 4.11.1 Digital display output



### 4.11.2 Description

- Communication error between outdoor unit main control board and inverter module.
- S-Therm Yukon stops running.
- Error code is displayed on outdoor unit main PCB and user interface.

### 4.11.3 Possible causes

- Power supply abnormal.
- Interference from a source of electromagnetic radiation.
- Outdoor unit main PCB or inverter driven module damaged.

### 4.11.4 Procedure

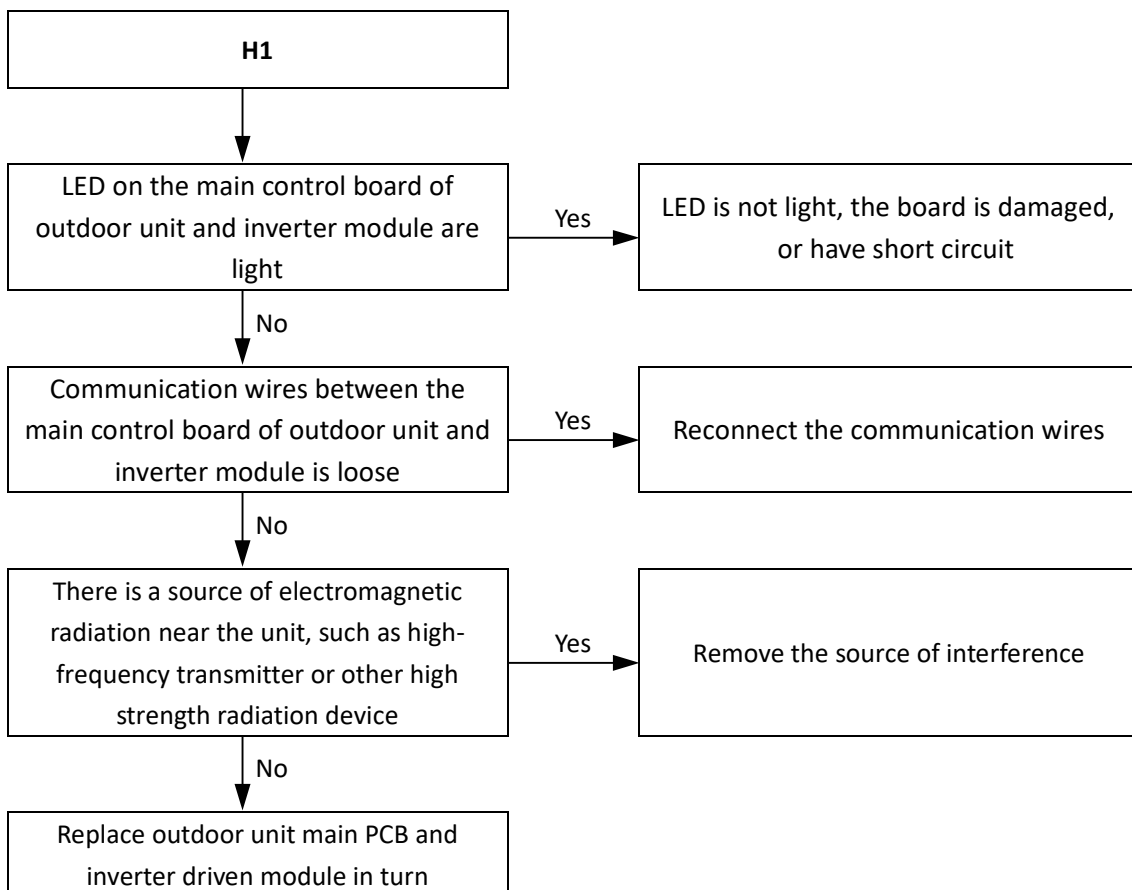

## 4.12 H6, HH Troubleshooting

### 4.12.1 Digital display output

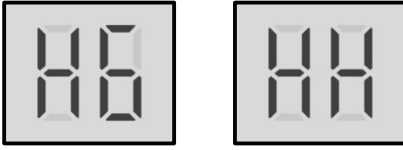

### 4.12.2 Description

- H6 indicates a DC fan error.
- HH indicates that H6 protection has occurred 10 times in 2 hours. When HH error occurs, a manual system restart is required before the system can resume operation. The cause of HH error should be addressed promptly in order to avoid system damage.
- S-Therm Yukon stops running.
- Error code is displayed on outdoor unit main PCB and user interface.

### 4.12.3 Possible causes

- DC fan wire is loosed.
- High wind speed.
- Fan motor blocked or has failed.
- Invert module damaged.
- Main PCB is damaged.

## S-Therm Yukon split series

### 4.12.4 Procedure

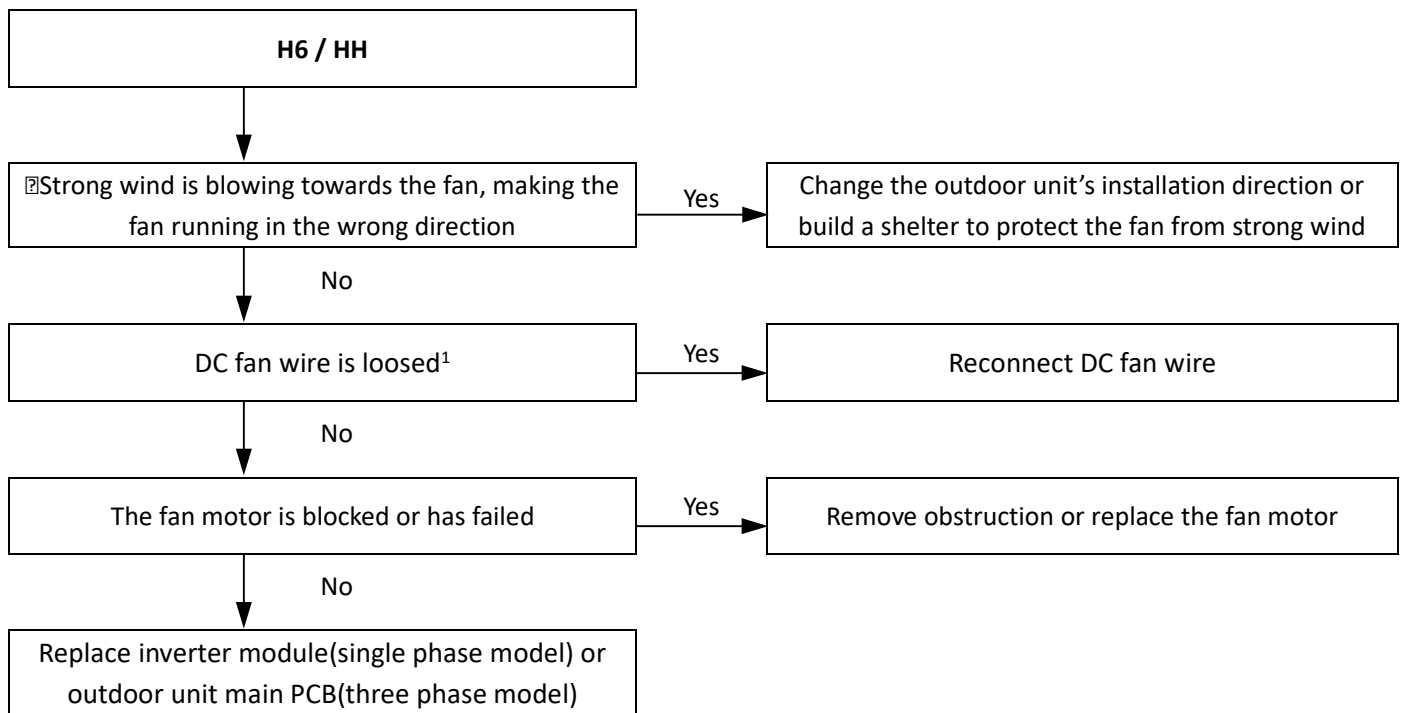

#### Notes:

1. Refer to Figures 4-1.1 to 4-1.4 in Part 4, 1.1 "Outdoor Unit Electric Control Box Layout" and to the S-Therm Yukon Engineering Data Book, Part 4 "Wiring Diagrams".
2. Measure the voltage between the DC fan motor power supply's white and black wires. The normal voltage is 15V when the unit is in standby. If the voltage is significantly different from 15V, the IPM module on the inverter module is damaged. DC fan connection are port CN19 on the MSH-60EB; MSH-80EB; MSH-100EB outdoor unit inverter module PCB (labeled 5 in Figure 4-2.5 in Part4, 2.3 "Main PCB for Refrigerant System, Inverter Module"). port CN19 on the MSH-120EB; MSH-140EB; MSH-160EB outdoor unit inverter module PCB (labeled 4 in Figure 4-2.6 in Part 4, 2. 3 "Main PCB for Refrigerant System, Inverter Module"), port CN109 on the MSH-120EB-3; MSH-140EB-3; MSH-160EB-3 outdoor unit refrigerant system main PCB (labeled 30 in Figure 4-2.4 in Part 4, 2. 3 "Main PCB for Refrigerant System, Inverter Module").

**4.13 H7 Troubleshooting****4.13.1 Digital display output****4.13.2 Description**

- Abnormal main circuit voltage.
- S-Therm Yukon stops running.
- Error code is displayed on outdoor unit main PCB and user interface.

**4.13.3 Possible causes**

- Power supply voltage not within 90%~110% of rated voltage.
- Outdoor unit main PCB is damaged.

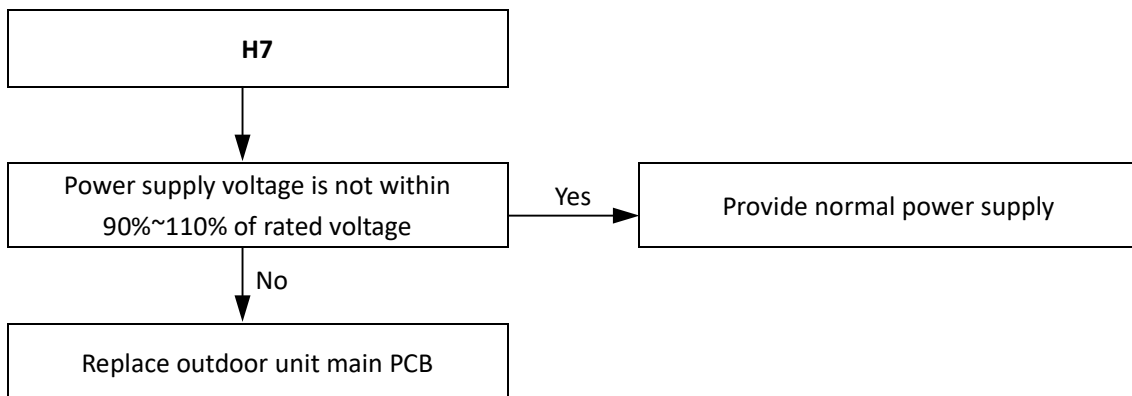
**4.13.4 Procedure**

## S-Therm Yukon split series

### 4.14 H8 Troubleshooting

#### 4.14.1 Digital display output



#### 4.14.2 Description

- Pressure sensor error.
- S-Therm Yukon stops running.
- Error code is displayed on outdoor unit main PCB and user interface.

#### 4.14.3 Possible causes

- Pressure sensor not connected properly or has malfunctioned.
- Outdoor unit main PCB is damaged.

#### 4.14.4 Procedure

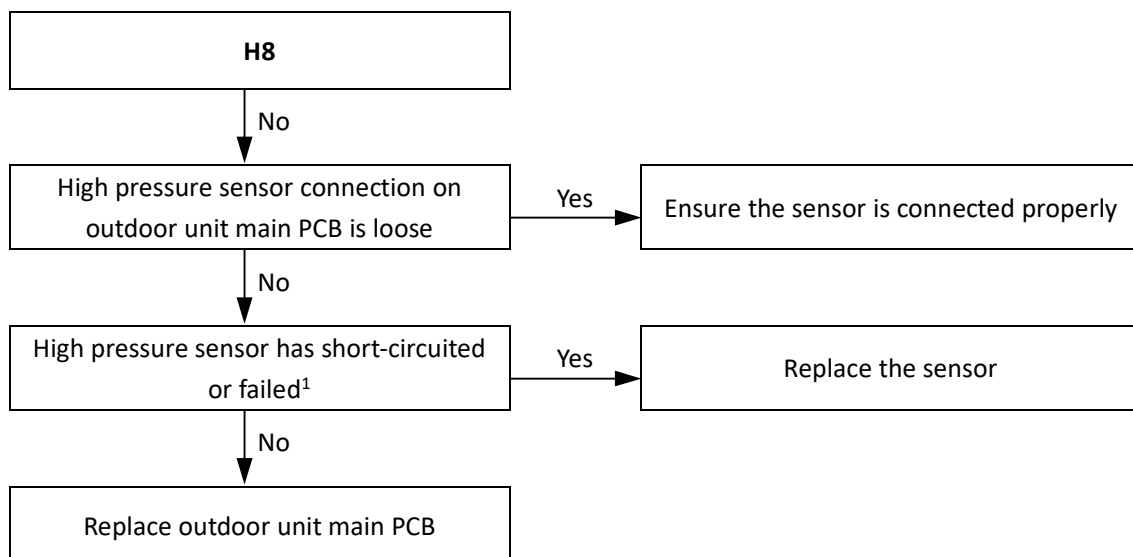

#### Notes:

1. Measure the resistance among the three terminals of the pressure sensor. If the resistance is of the order of mega Ohms or infinite, the pressure sensor has failed. The pressure sensor connection are port CN4 on the MSH-60EB; MSH-80EB; MSH-100EB outdoor unit refrigerant system main PCB (labeled 19 in Figure 4-2.2 in Part4, 2.3 "Main PCB for Refrigerant System, Inverter Module"). port CN4 on the MSH-120EB; MSH-140EB; MSH-160EB outdoor unit refrigerant system main PCB (labeled 19 in Figure 4-2.3 in Part 4, 2. 3 "Main PCB for Refrigerant System, Inverter Module"), port CN6 on the MSH-120EB-3; MSH-140EB-3; MSH-160EB-3 outdoor unit refrigerant system main PCB (labeled 13 in Figure 4-2.4 in Part 4, 2. 3 "Main PCB for Refrigerant System, Inverter Module").

## 4.15 P0, HP Troubleshooting

### 4.15.1 Digital display output

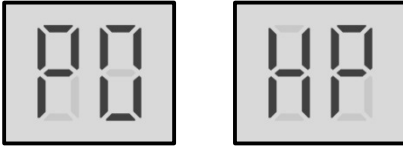

### 4.15.2 Description

- P0 indicates suction pipe low pressure protection. When the suction pressure falls below 0.14MPa, the system displays P0 protection and S-Therm Yukon stops running. When the pressure rises above 0.3MPa, P0 is removed and normal operation resumes.
- HP indicates  $P_e < 0.6\text{Mpa}$  occurred 3 times in an hour.
- Error code is displayed on outdoor unit main PCB and user interface.

### 4.15.3 Possible causes

- Low pressure switch not connected properly or has malfunctioned.
- Insufficient refrigerant.
- Low pressure side blockage.
- Poor evaporator heat exchange in heating mode or DHW mode.
- Insufficient water flow in cooling mode.
- Outdoor unit main PCB damaged.

# S-Therm Yukon split series



## 4.15.4 Procedure

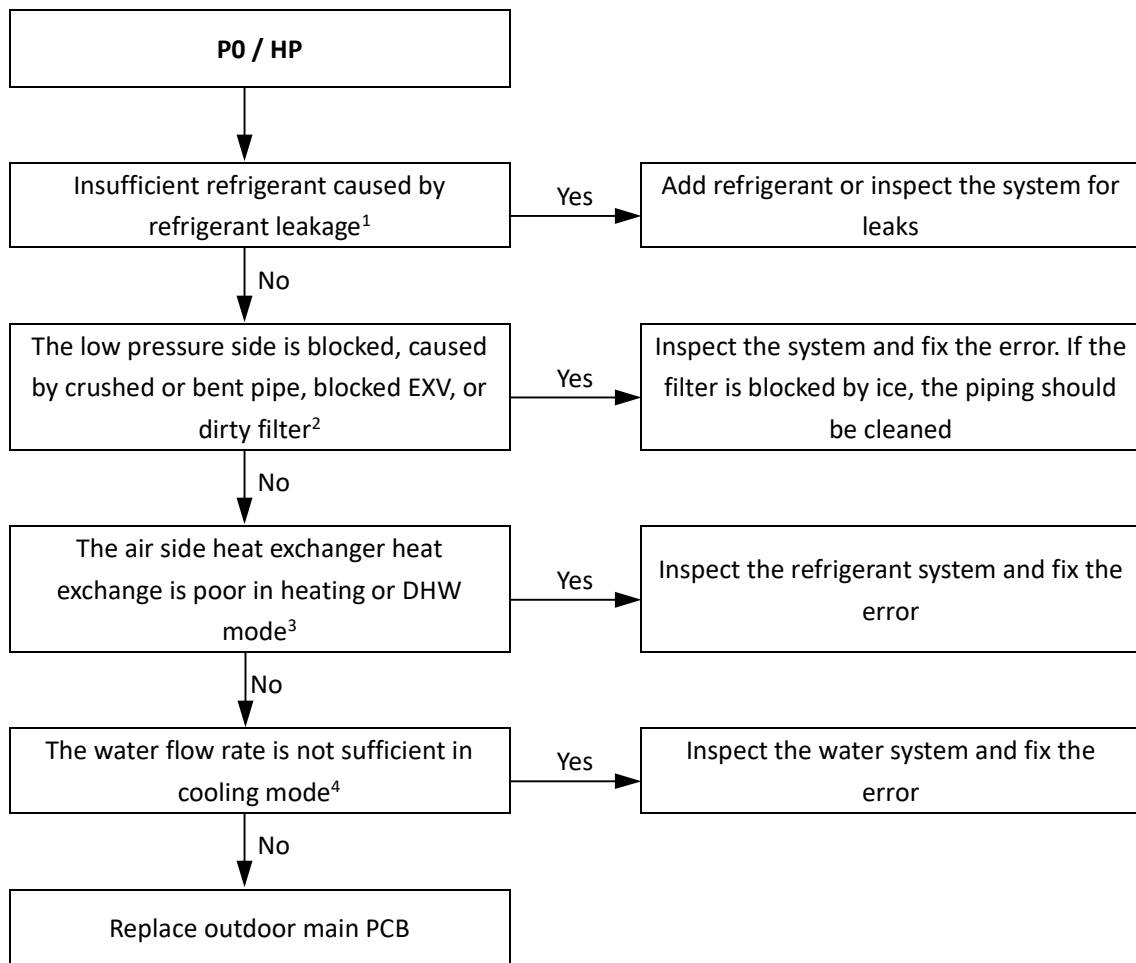

Notes: ☐

1. To check for insufficient refrigerant:  
An insufficiency of refrigerant causes compressor discharge temperature to be higher than normal, discharge and suction pressures to be lower than normal and compressor current to be lower than normal, and may cause frosting to occur on the suction pipe. These issues disappear once sufficient refrigerant has been charged into the system.
2. A low pressure side blockage causes compressor discharge temperature to be higher than normal, suction pressure to be lower than normal and compressor current to be lower than normal, and may cause frosting to occur on the suction pipe. For normal system parameters.
3. Check air side heat exchanger, fan and air outlets for dirt/blockages.
4. Check water side heat exchanger, water piping, circulator pumps and water flow switch for dirt/blockages.

**4.16 P1 Troubleshooting****4.16.1 Digital display output****4.16.2 Description**

- Discharge pipe high pressure protection. When the discharge pressure rises above 4.3MPa, the system displays P1 protection and S-Therm Yukon stops running. When the discharge pressure falls below 3.6MPa, P1 is removed and normal operation resumes.
- Error code is displayed on outdoor unit main PCB and user interface.

**4.16.3 Possible causes**

- Pressure sensor/switch not connected properly or has malfunctioned.
- Excess refrigerant.
- System contains air or nitrogen.
- High pressure side blockage.
- Poor condenser heat exchange.
- Outdoor unit main PCB damaged.

# S-Therm Yukon split series



## 4.16.4 Procedure

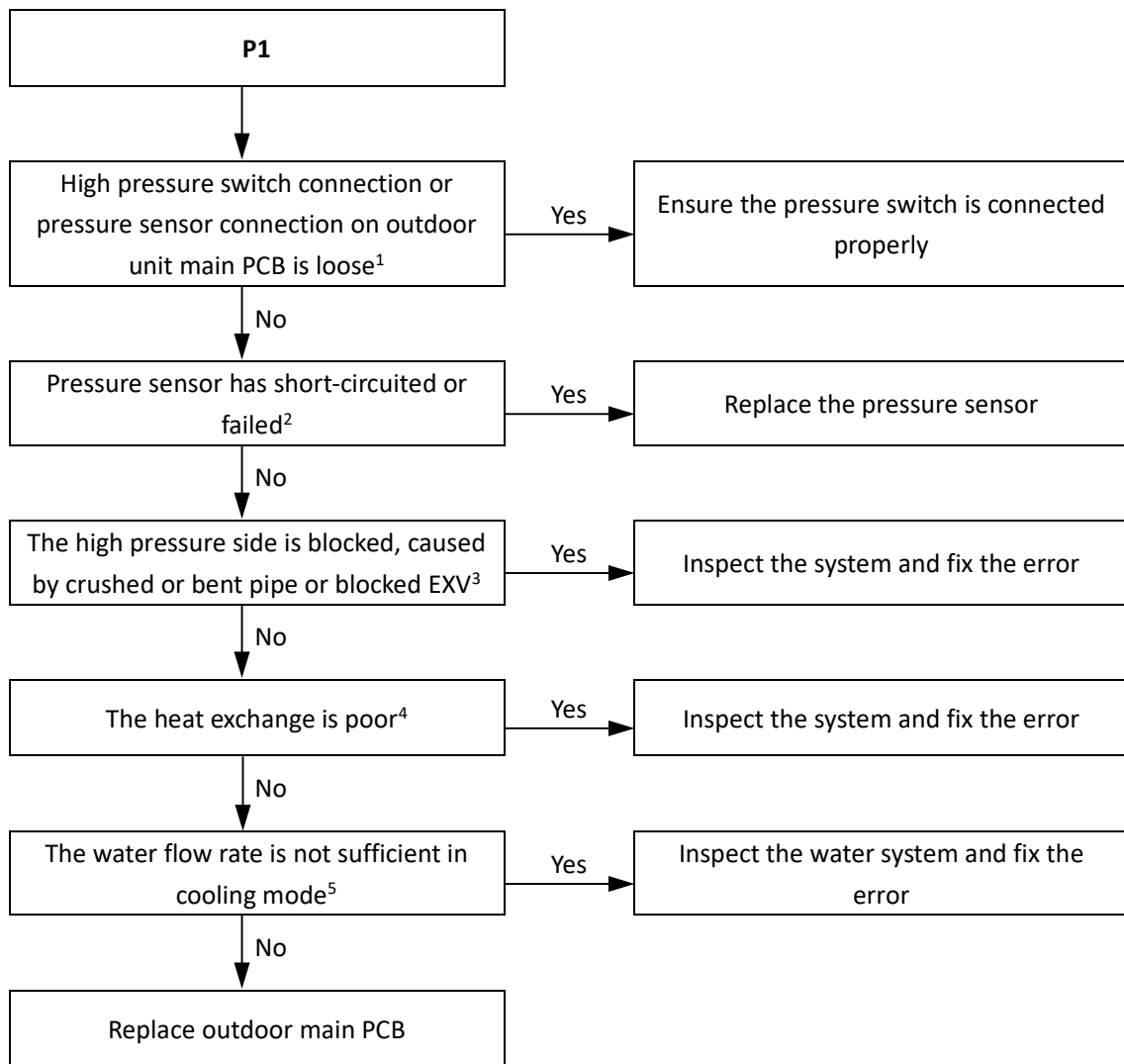

**Notes:**

1. High pressure switch connection is port CN13 on the MSH-60EB; MSH-80EB; MSH-100EB outdoor unit refrigerant system main PCB (labeled 16 in Figure 4-2.2 in Part 4, 2.3 "Main PCB for Refrigerant System, Inverter Module"). port CN13 on the MSH-120EB; MSH-140EB; MSH-160EB outdoor unit refrigerant system main PCB (labeled 16 in Figure 4-2.3 in Part 4, 2. 3 "Main PCB for Refrigerant System, Inverter Module"), port CN31 on the MSH-120EB-3; MSH-140EB-3; MSH-160EB-3 outdoor unit refrigerant system main PCB (labeled 20 in Figure 4-2.4 in Part 4, 2. 3 "Main PCB for Refrigerant System, Inverter Module").
2. Measure the resistance among the three terminals of the pressure sensor. If the resistance is of the order of mega Ohms or infinite, the pressure sensor has failed.
3. High pressure side blockage causes discharge temperature to be higher than normal, discharge pressure to be higher than normal and suction pressure to be lower than normal.
4. In heating mode check water side heat exchanger, water piping, circulator pumps and water flow switch for dirt/blockages. In cooling mode check air side heat exchanger, fan(s) and air outlets for dirt/blockages.
5. Check water pressure on the manometer. If the water pressure is not > 1 bar, water flow is insufficient. Refer to Figure 2-1.9 in Part 2, 1.2 "Hydronic Box Layout".

## 4.17 P3 Troubleshooting

### 4.17.1 Digital display output



### 4.17.2 Description

- Compressor current protection.
- When the compressor current rises above the protection value (4/6kW models 18A, 8/10kW model 19A, 12/14/16kW single phase model 30A, 12/14/16kW three phase model 14A,), the system displays P3 protection and S-Therm Yukon stops running. When the current returns to the normal range, P3 is removed and normal operation resumes.
- Error code is displayed on refrigerant system main PCB and user interface.

### 4.17.3 Possible causes

- Poor condenser heat exchange.
- High pressure side blockage.
- Inverter module damaged.
- Compressor damaged.
- Outdoor unit main PCB damaged.

# S-Therm Yukon split series



## 4.17.4 Procedure

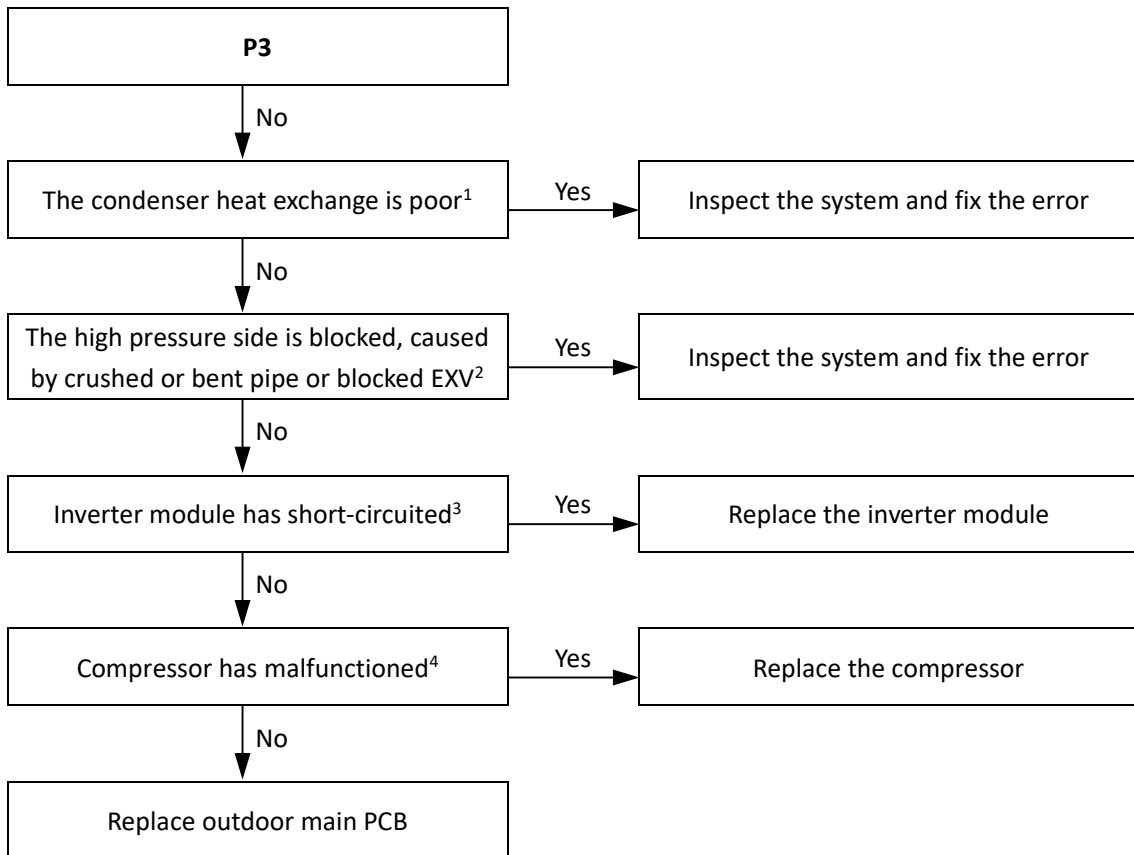

### Notes:

1. In heating mode check water side heat exchanger, water piping, circulator pumps and water flow switch for dirt/blockages. In cooling mode check air side heat exchanger, fan and air outlets for dirt/blockages.
2. High pressure side blockage causes discharge temperature to be higher than normal, discharge pressure to be higher than normal and suction pressure to be lower than normal.
3. Set a multi-meter to buzzer mode and test any two terminals of P N and U V W of the inverter module. If the buzzer sounds, the inverter module has short-circuited.
4. The normal resistances of the inverter compressor are 0.7-1.5Ω among U V W and infinite between each of U V W and ground. If any of the resistances differ from these specifications, the compressor has malfunctioned.

**4.18 P4 Troubleshooting****4.18.1 Digital display output****4.18.2 Description**

- Discharge temperature protection.
- When the compressor the discharge temperature rises above 115°C, the system displays P4 protection and S-Therm Yukon stops running. When the discharge temperature falls below 95°C, P4 is removed and normal operation resumes.
- Error code is displayed on refrigerant system main PCB and user interface.

**4.18.3 Possible causes**

- Temperature sensor error
- High pressure side blockage.
- Poor condenser heat exchange.
- Outdoor unit main PCB damaged.

# S-Therm Yukon split series



## 4.18.4 Procedure

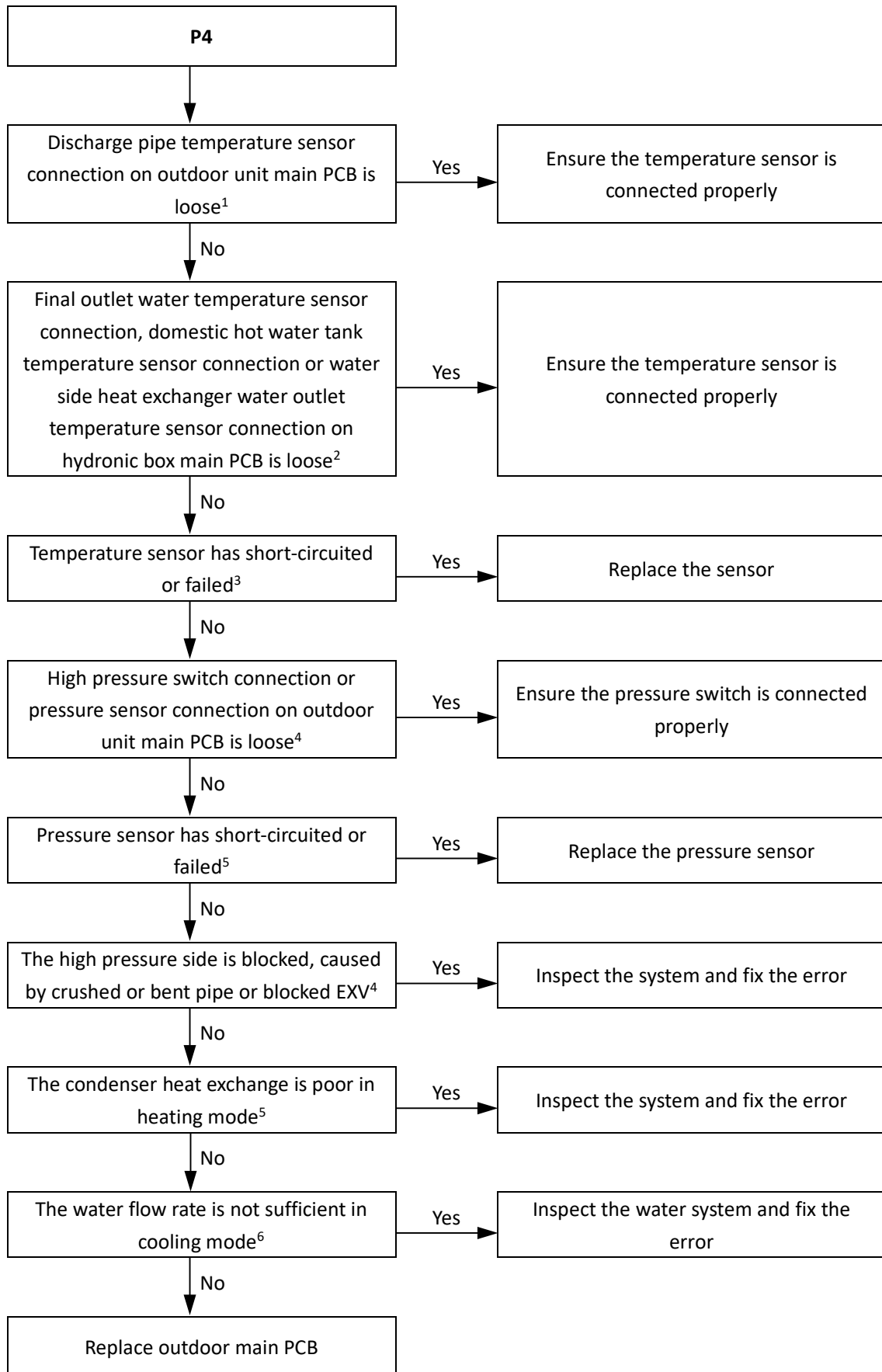

Notes:

1. Discharge pipe temperature sensor connection is port CN8 on the MSH-60EB; MSH-80EB; MSH-100EB outdoor unit refrigerant system main PCB (labeled 15 in Figure 4-2.2 in Part4, 2.3 "Main PCB for Refrigerant System, Inverter Module"). port CN8 on the MSH-120EB; MSH-140EB; MSH-160EB outdoor unit refrigerant system main PCB (labeled 15 in Figure 4-2.3 in Part 4, 2. 3 "Main PCB for Refrigerant System, Inverter Module"), port CN4 on the MSH-120EB-3; MSH-140EB-3; MSH-160EB-3 outdoor unit refrigerant system main PCB (labeled 15 in Figure 4-2.4 in Part 4, 2. 3 "Main PCB for Refrigerant System, Inverter Module").
2. Final outlet water temperature sensor and water side heat exchanger water outlet temperature sensor connections are port CN6 on the hydronic box main PCB (labeled 10 in Figure 4-2.1 in Part4, 2.2 "Main PCB for Hydronic System"). Domestic hot water tank temperature sensor connection is port CN13 on hydronic box main PCB (labeled 13 in Figure 4-2.1 in Part4, 2.2 "Main PCB for Hydronic System").
3. Measure sensor resistance. If the resistance is too low, the sensor has short-circuited. If the resistance is not consistent with the sensor's resistance characteristics table, the sensor has failed. Refer to Part 2, 1 "Layout of Functional Components" and to Table 5-5.1 or 5-5.2 in Part 5, 5.1 "Temperature Sensor Resistance Characteristics".
4. High pressure switch connection is port CN13 on the MSH-60EB; MSH-80EB; MSH-100EB outdoor unit refrigerant system main PCB (labeled 16 in Figure 4-2.2 in Part4, 2.3 "Main PCB for Refrigerant System, Inverter Module"). port CN13 on the MSH-120EB; MSH-140EB; MSH-160EB outdoor unit refrigerant system main PCB (labeled 16 in Figure 4-2.3 in Part 4, 2. 3 "Main PCB for Refrigerant System, Inverter Module"), port CN31 on the MSH-120EB-3; MSH-140EB-3; MSH-160EB-3 outdoor unit refrigerant system main PCB (labeled 20 in Figure 4-2.4 in Part 4, 2. 3 "Main PCB for Refrigerant System, Inverter Module").
5. Measure the resistance among the three terminals of the pressure sensor. If the resistance is of the order of mega Ohms or infinite, the pressure sensor has failed.
6. High pressure side blockage causes discharge temperature to be higher than normal, discharge pressure to be higher than normal and suction pressure to be lower than normal.
7. Check air side heat exchanger, fan and air outlets for dirt/blockages.
8. Check the water side heat exchanger, water piping, circulator pumps and water flow switch for dirt/blockages.

## S-Therm Yukon split series

### 4.19 P5 Troubleshooting

#### 4.19.1 Digital display output



#### 4.19.2 Description

- High temperature difference between water side heat exchanger water inlet and water outlet temperatures protection.
- S-Therm Yukon stops running.
- Error code is displayed on hydronic box main PCB and user interface.

#### 4.19.3 Possible causes

- Temperature sensor not connected properly or has malfunctioned.
- Water piping contains air.
- Insufficient water flow.
- Hydronic box main PCB damaged.

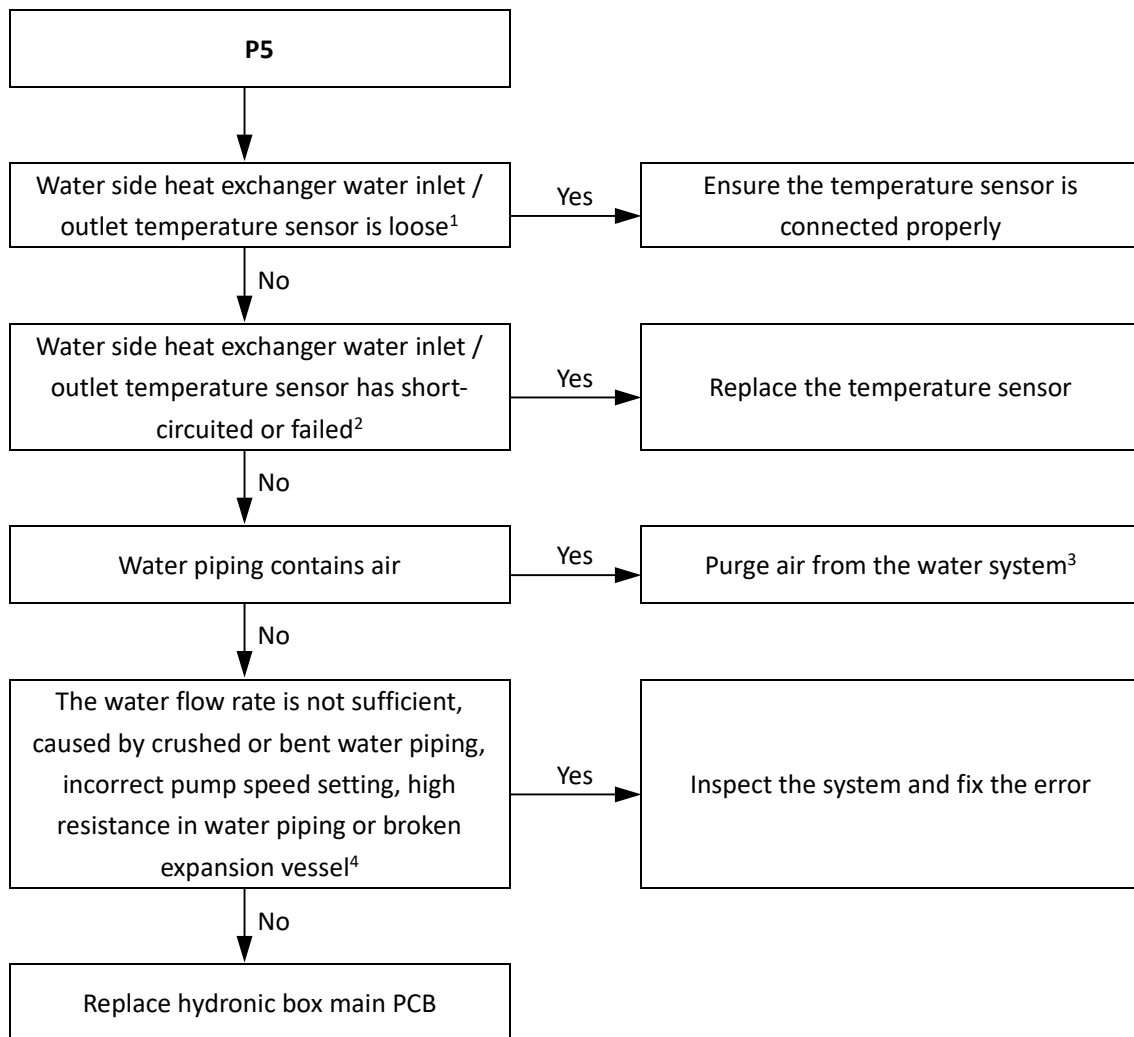
**4.19.4 Procedure**

**Notes:**

1. Water side heat exchanger water inlet temperature sensor and water side heat exchanger water outlet temperature sensor connections are port CN6 on the hydronic box main PCB (labeled 10 in Figure 4-2.1 in Part 4, 2.2 "Main PCB for Hydronic System").
2. Measure sensor resistance. If the resistance is too low, the sensor has short-circuited. If the resistance is not consistent with the sensor's resistance characteristics table, the sensor has failed. Refer to Part 2, 1.2 "Hydronic Box Layout" and to Table 5-5.3 in Part 5, 5.1 "Temperature Sensor Resistance Characteristics".
3. Refer to the S-Therm Yukon Engineering Data Book, Part 5, 15 "SPECIAL FUNCTIONS".
4. Check water pressure on the manometer. If the water pressure is not > 1 bar, water flow is insufficient. Refer to Figures 2-1.7 and 2-1.8 in Part 2, 1.2 "Hydronic Box Layout".

## S-Therm Yukon split series

### 4.20 Inverter module Troubleshooting for single-phase models

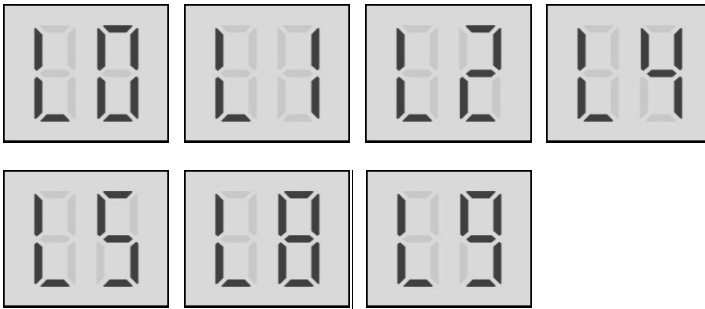
#### 4.20.1 Digital display output



#### 4.20.2 Description

- Inverter module protection.
- S-Therm Yukon stops running.
- Specific error code L0, L1, L2, L4, L5, L8, L9 is displayed on the user interface and the main control board of refrigerant system.

#### 4.20.3 Possible causes

- Inverter module protection.
- DC bus low or high voltage protection.
- MCE error(DC bus low or high voltage protection or software over current protection)
- Zero speed protection.
- Excessive compressor frequency variation.
- Actual compressor frequency differs from target frequency.
- High pressure protection.
- PED board self checking fail.

#### 4.20.4 Specific error codes for inverter module protection

Table 4-4.1: Specific error codes

Specific error code	Content
L0	Inverter module protection
L1	DC bus low voltage protection
L2	DC bus high voltage protection
L4	MCE error(DC bus low or high voltage protection or software over current protection)
L5	Zero speed protection
L8	Compressor frequency variation greater than 15Hz within 1 second protection
L9	Actual compressor frequency differs from target frequency by more than 15Hz protection

The specific error codes can also be obtained from the LED indicators on the inverter module.

*Table 4-4.2: Errors indicated on LED, single-phase 4~10kW*

LED301 flashing pattern (GREEN) LED302 is always on (RED)	Corresponding error
Flashes 8 times and stops for 1 second, then repeats	L0 - Inverter module protection
Flashes 9 times and stops for 1 second, then repeats	L1 - DC bus low voltage protection
Flashes 10 times and stops for 1 second, then repeats	L2 - DC bus high voltage protection
Flashes 12 times and stops for 1 second, then repeats	L4 - MCE error
Flashes 13 times and stops for 1 second, then repeats	L5 - Zero speed protection
Flashes 16 times and stops for 1 second, then repeats	L8 - Compressor frequency variation greater than 15Hz within one second protection
Flashes 17 times and stops for 1 second, then repeats	L9 - Actual compressor frequency differs from target frequency by more than 15Hz protection

*Table 4-4.3: Errors indicated on LED, single-phase 4~10kW*

LED1 flashing pattern (GREEN) LED2 is always on (RED)	Corresponding error
Flashes 3 times and stops for 1 second, then repeats	P1 - High pressure protection
Flashes 5 times and stops for 1 second, then repeats	bH – PED board checking fail
Flashes 8 times and stops for 1 second, then repeats	L0 - Inverter module protection
Flashes 9 times and stops for 1 second, then repeats	L1 - DC bus low voltage protection
Flashes 10 times and stops for 1 second, then repeats	L2 - DC bus high voltage protection
Flashes 12 times and stops for 1 second, then repeats	L4 - MCE error
Flashes 13 times and stops for 1 second, then repeats	L5 - Zero speed protection
Flashes 16 times and stops for 1 second, then repeats	L8 - Compressor frequency variation greater than 15Hz within one second protection
Flashes 17 times and stops for 1 second, then repeats	L9 - Actual compressor frequency differs from target frequency by more than 15Hz protection

*Figure 4-4.1: LED location of inverter module*

Inverter Module(4-10KW): LED301/302/303

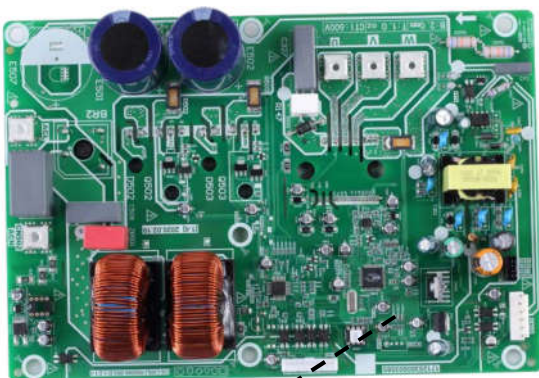

Inverter Module(12-16KW): LED1/LED2/LED3



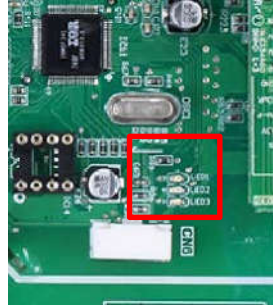
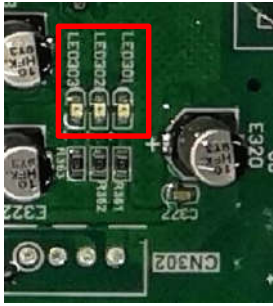

4.20.5 Principle of DC inverter

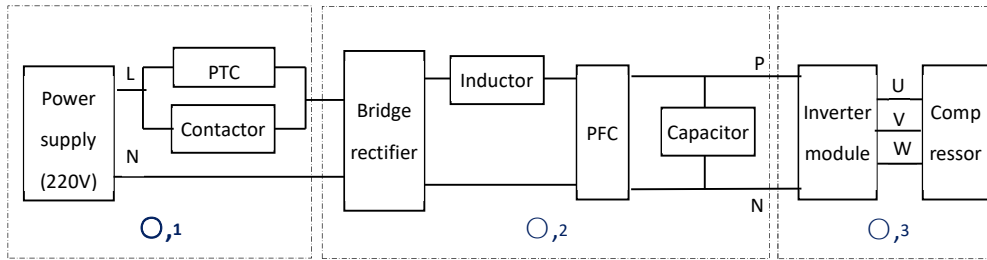

- ① Contactor is open, the current across the PTC to charge capacitor. After 5 seconds, the contactor closed.
- ② 220-240V AC power supply change to DC power supply after bridge rectifier.
- ③ The capacitor output steady power supply for inverter module P N terminals. In standby the voltage between P and N terminal on inverter module is 1.4 time of AC power supply. When the fan motor is running, the voltage is 377V DC.

4.20.6 L0/L4 troubleshooting

Situation 1: L0 or L4 error appears immediately after the outdoor unit is powered-on

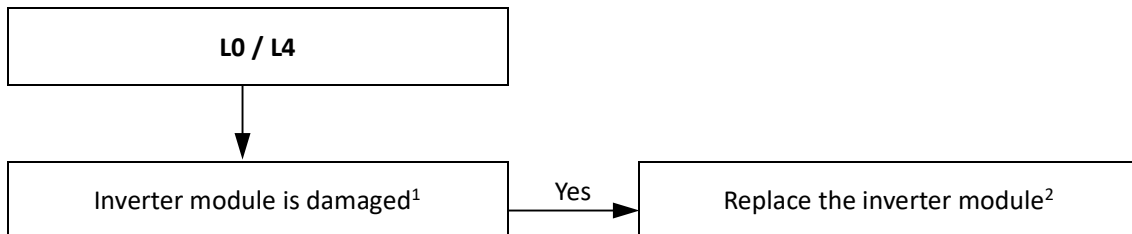

Notes:

- 1. Measure the resistance between each of U, V and W and each of P and N on the inverter module. All the resistances should be infinite. If any of them are not infinite, the inverter module is damaged and should be replaced. Refer to Figure 4-2.5 to 4-2.7 in Part 4, 2.1 "Main PCBs for Refrigerant System, Inverter Module".
- 2. When replacing an inverter module, a layer of thermally conductive silica gel should be painted on the IPM module, IGBT, diode, bridge rectifier (on the reverse side of the inverter module). Refer to Figure 4-4.2.

Figure 4-4.2: Replacing an inverter module

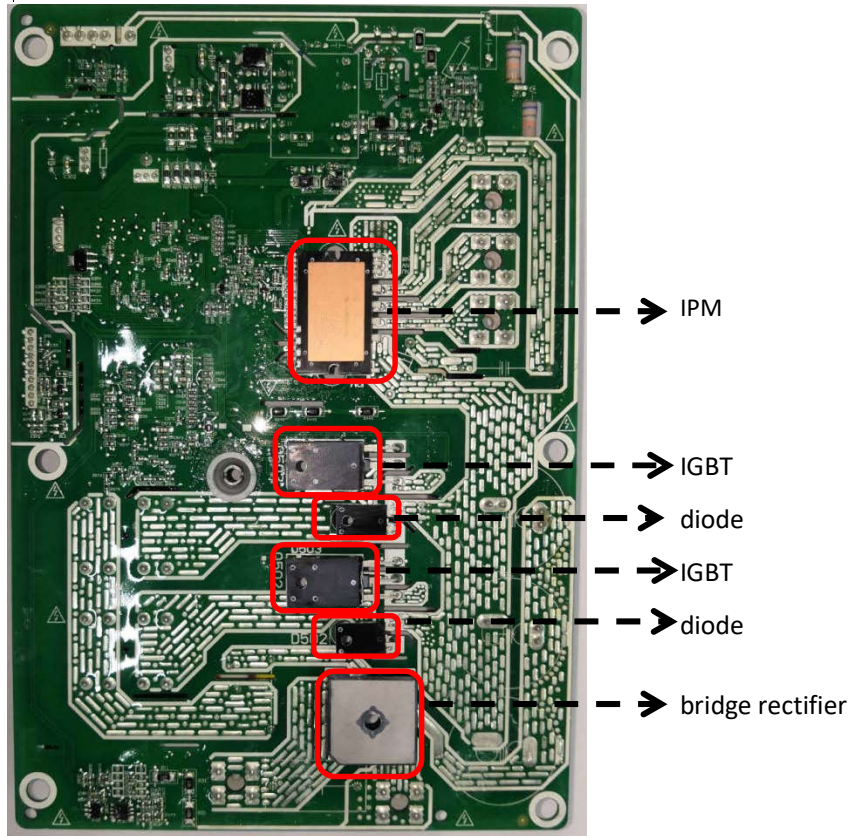
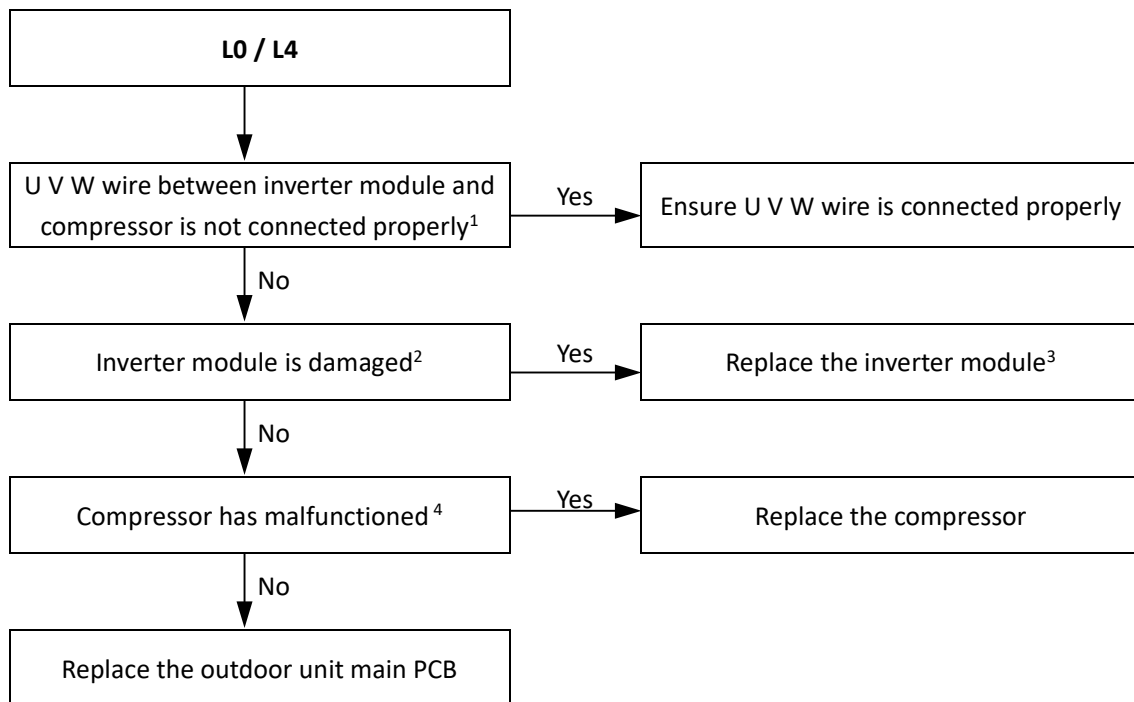
**Situation 2: L0 or L4 error appears immediately after the compressor starts up**

**Notes:**

1. Connect the U V W wire from the inverter module to the correct compressor terminals, as indicated by the labels on the compressor.
2. Measure the resistance between each of U, V and W and each of P and N on the inverter module. All the resistances should be infinite. If any of them are not infinite, the inverter module is damaged and should be replaced. Refer to Figure 4-2.5 to 4-2.7 in Part 4, 2.1 "Main PCBs for Refrigerant System, Inverter Module".
3. When replacing an inverter module, a layer of thermally conductive silica gel should be painted on the IPM module, IGBT, diode bridge rectifier (on the reverse side of the inverter module PCB). Refer to Figure 4-4.2.
4. The normal resistances of the inverter compressor are 0.7-1.5Ω among U V W and infinite between each of U V W and ground. If any of the resistances differ from these specifications, the compressor has malfunctioned.

## S-Therm Yukon split series

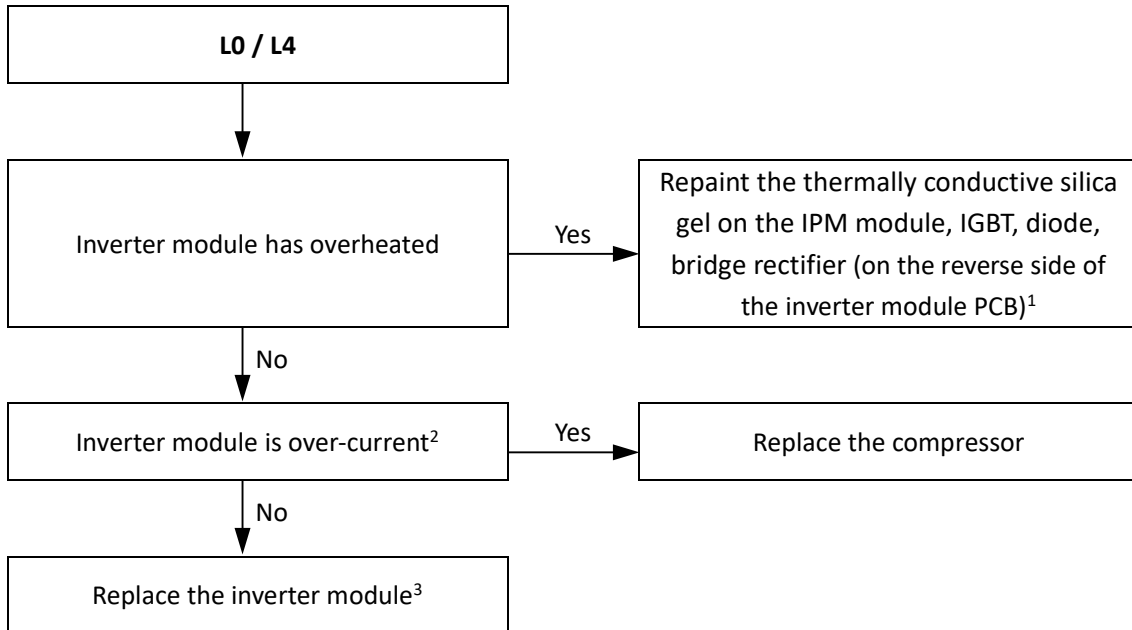
**Situation 3: L0 or L4 error appears after the compressor has been running for a period of time and the compressor speed is over 60rps**



Notes:

1. Refer to Figure 4-4.2.
2. Use clip-on ammeter to measure the compressor current, if the current is normal indicates the inverter module is failed, if the current is abnormal indicates the compressor is failed.
3. When replacing an inverter module, a layer of thermally conductive silica gel should be painted on the PFC and IPM modules (on the reverse side of the inverter module PCB). Refer to Figure 4-4.2.

### Situation 4: L0 error appears occasionally/irregularly

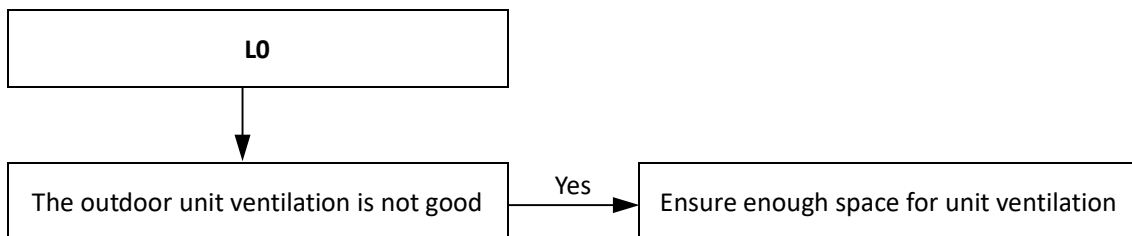

**4.20.7 L1/L2 troubleshooting**

The normal DC voltage between terminals P and N on inverter module is 1.4 time of AC power supply in standby, the DC voltage is 377V when the fan motor is running. If the voltage is lower than 160V, the unit displays L1. If the voltage is higher than 500V, the unit display L2.

Figure 4-4.3: Inverter module terminals

Inverter module terminals (4-10KW)

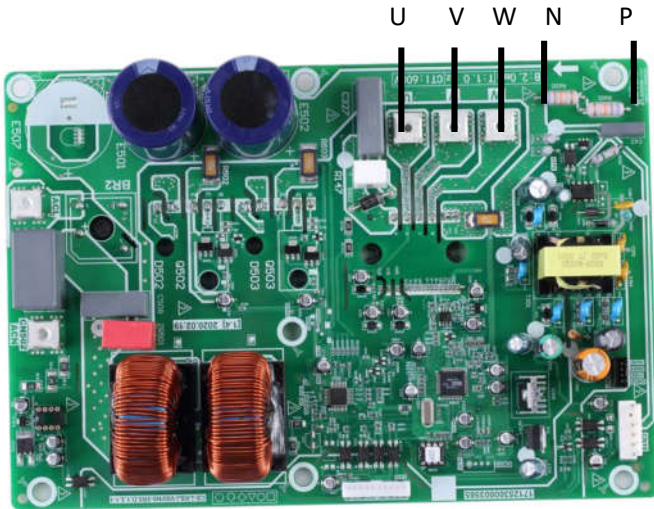

Inverter module terminals (12-16KW)

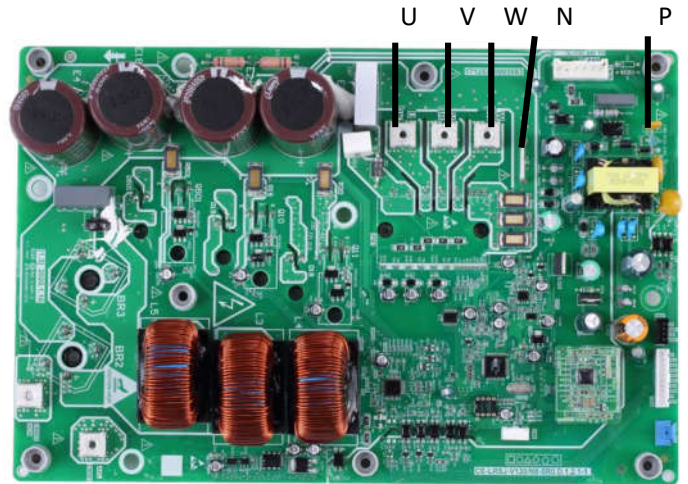
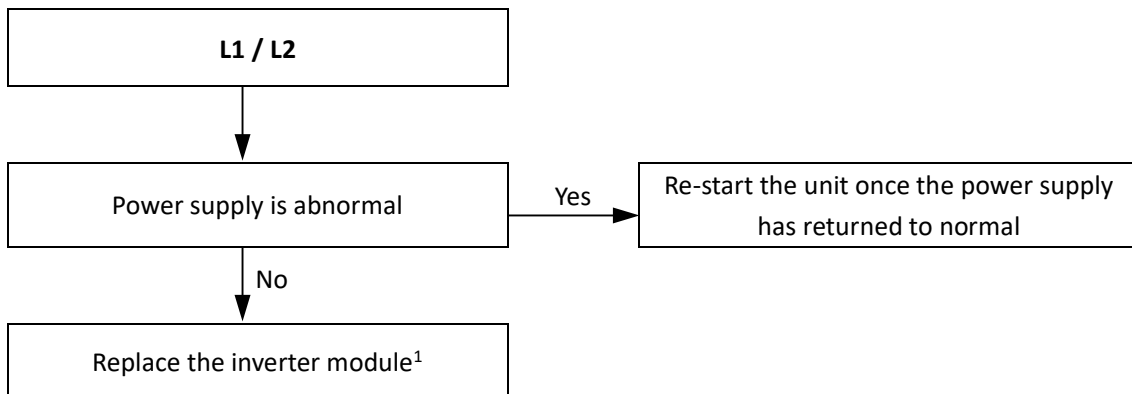
**Situation 1: L1 or L2 error appears immediately after the outdoor unit is powered-on**

Notes:

- When replacing an inverter module, a layer of thermally conductive silica gel should be painted on the IPM module, IGBT, diode, bridge rectifier (on the reverse side of the inverter module PCB). Refer to Figure 4-4.2.

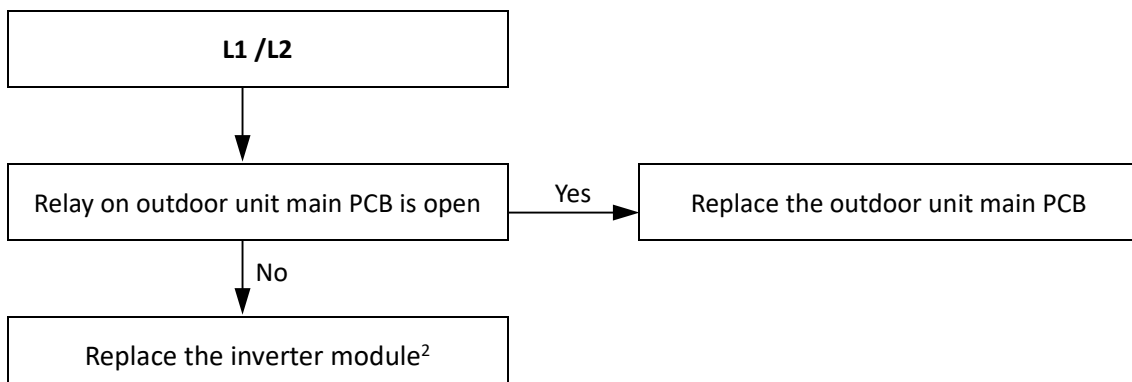
**Situation 2: L1 or L2 error appears after the compressor has been running for a period of time and the compressor speed is over 20rps**

Notes:

1. If the fan motor is running and the DC voltage between terminals P and N on inverter module declined, Relay on the main control board of outdoor unit is open.
2. When replacing an inverter module, a layer of thermally conductive silica gel should be painted on IPM module (on the reverse side of the inverter module PCB). Refer to Figure 4-4.2.

Figure 4-4.4: Relay location of main PCB for refrigerant system  
Single phase 4/6/8/10kW unit

Single phase 12/14/16kW unit

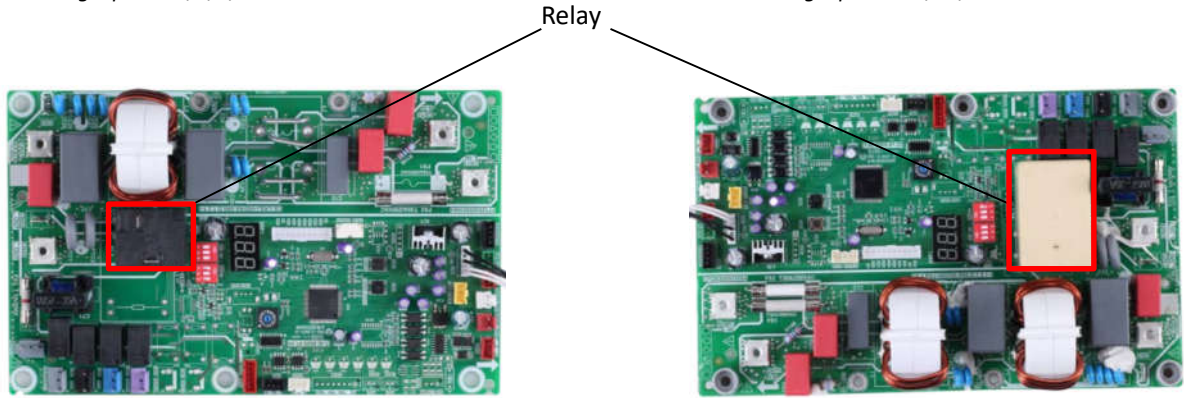

### 4.20.8 L5/L8/L9 troubleshooting

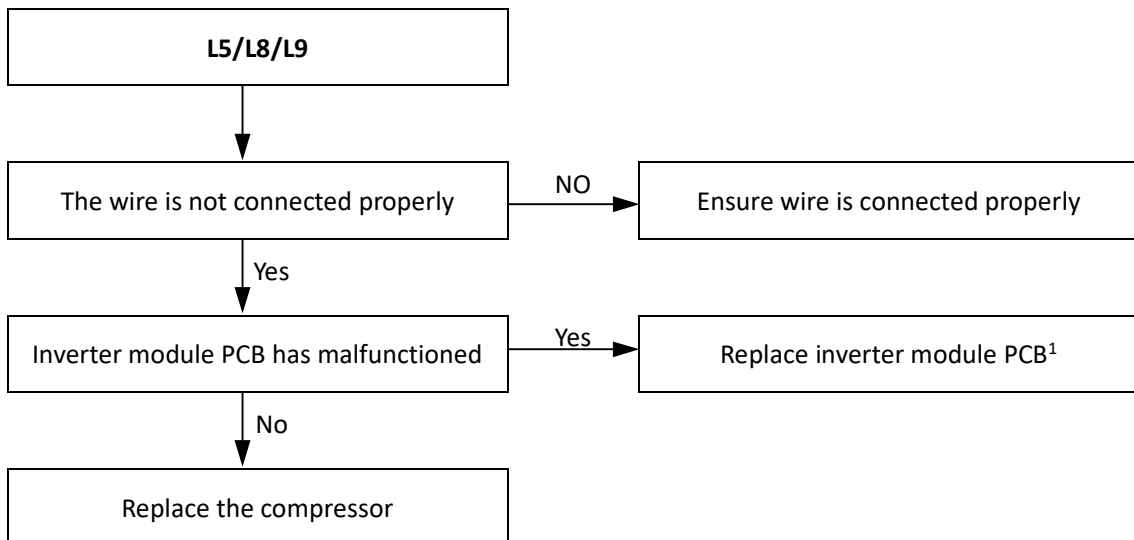

1. When replacing an inverter module, a layer of thermally conductive silica gel should be painted on IPM module (on the reverse side of the inverter module PCB). Refer to Figure 4-4.2.

## 4.21 Inverter module Troubleshooting for three-phase models

### 4.21.1 Digital display output

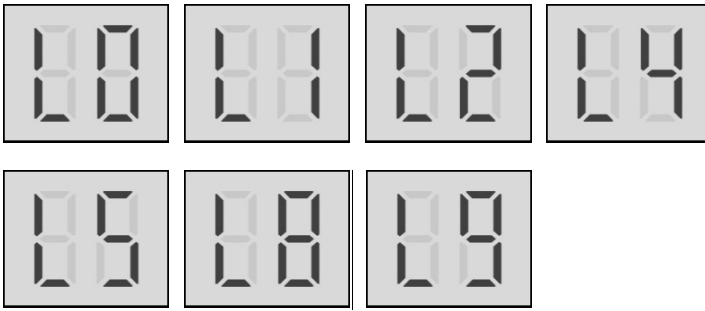

### 4.21.2 Description

- Inverter module protection or high pressure protection.
- M thermal Mono stops running.
- Specific error code L0, L1, L2, L4, L5, L8, L9 is displayed on the user interface and the refrigerant system main PCB.

### 4.21.3 Possible causes

- Inverter module protection.
- DC bus low or high voltage protection.
- MCE error(DC bus low or high voltage protection or software over current protection)
- Zero speed protection.
- Excessive compressor frequency variation.
- Actual compressor frequency differs from target frequency.
- High pressure protection.
- Contactor stuck or 908 self checking fail.

### 4.21.4 Specific error codes for inverter module protection

Table 4-4.4: Specific error codes

Specific error code	Content
L0	Inverter module protection
L1	DC bus low voltage protection
L2	DC bus high voltage protection
L4	MCE error(DC bus low or high voltage protection or software over current protection)
L5	Zero speed protection
L8	Compressor frequency variation greater than 15Hz within one second protection
L9	Actual compressor frequency differs from target frequency by more than 15Hz protection

# S-Therm Yukon split series



The specific error codes can also be obtained from the LED indicators LED1/LED2 on the inverter module.

LED1/2 flashing pattern	Corresponding error
Flashes 8 times and stops for 1 second, then repeats	L0 - Inverter module protection
Flashes 9 times and stops for 1 second, then repeats	L1 - DC bus low voltage protection
Flashes 10 times and stops for 1 second, then repeats	L2 - DC bus high voltage protection
Flashes 12 times and stops for 1 second, then repeats	L4 - MCE error(DC bus low or high voltage protection or software over current protection)
Flashes 13 times and stops for 1 second, then repeats	L5 - Zero speed protection
Flashes 17 times and stops for 1 second, then repeats	L8 - Compressor frequency variation greater than 15Hz within one second protection L9 - Actual compressor frequency differs from target frequency by more than 15Hz protection
Flashes 3 times and stops for 1 second, then repeats	bH - Contactor stuck or 908 self checking fail
Flashes 5 times and stops for 1 second, then repeats	P1 - High pressure protection

Figure 4-4.5: LED location of inverter module for three-phase 12~16kW unit

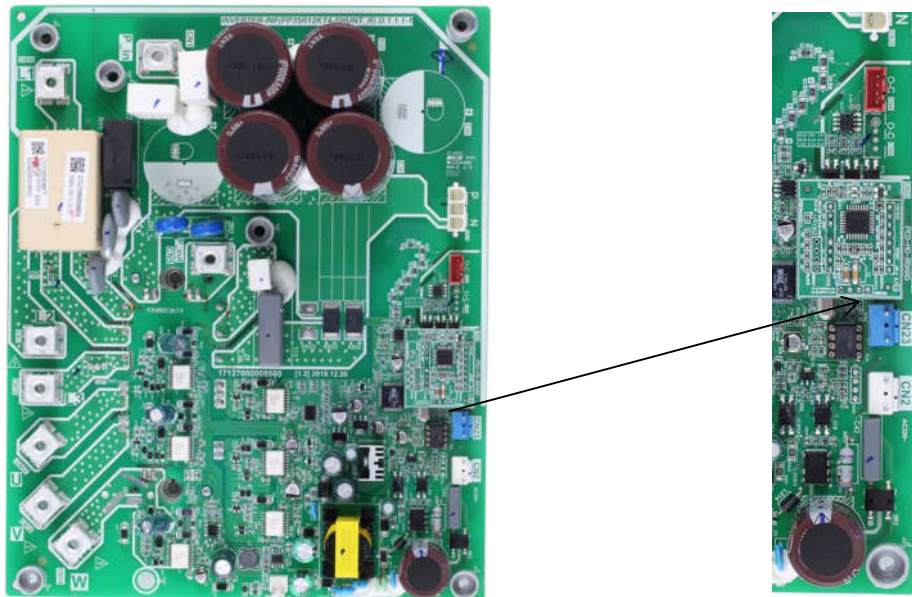

## 4.21.5 Principle of DC inverter

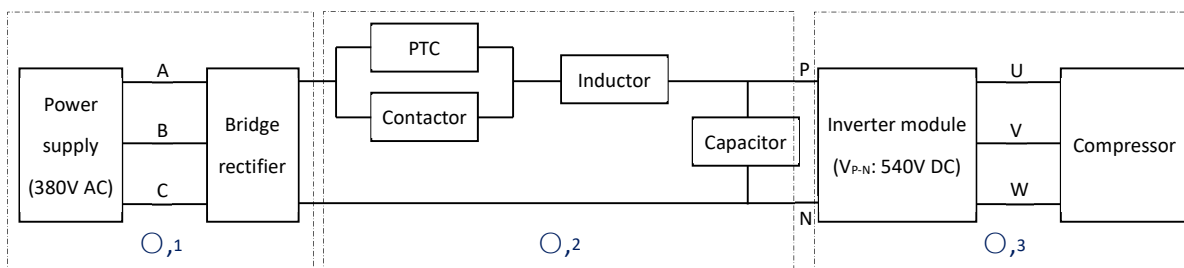

- ① 380-415V AC power supply change to DC power supply after bridge rectifier.
- ② Contactor is open the current across the PTC to charge capacitor, after 5 seconds the contactor closed.
- ③ The capacitor output steady 540V DC power supply for inverter module P N terminals.

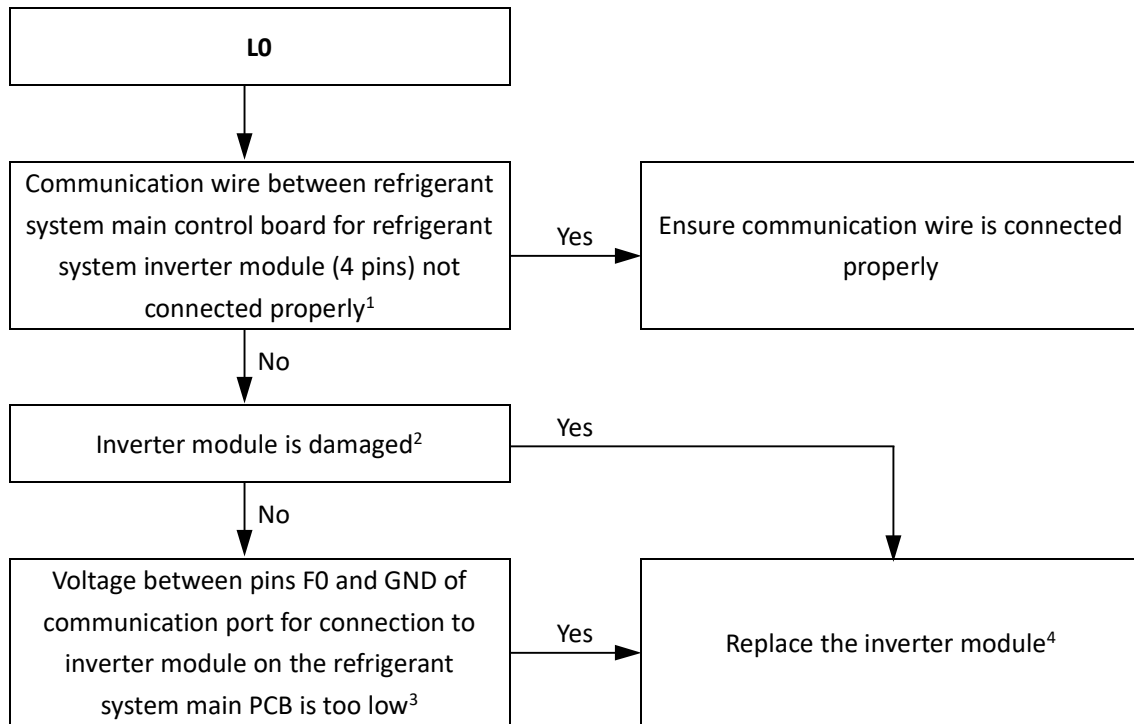
**4.21.6 L0 troubleshooting**
**Situation 1: L0 error appears immediately after the outdoor unit is powered-on**

**Notes:**

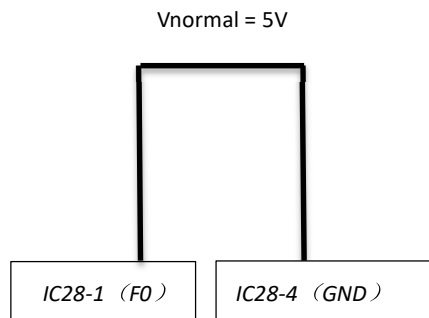
1. For MHC-V12(14,16)W/D2RN8-B, the communication port between refrigerant system main control board for refrigerant system inverter module is port CN36 on refrigerant system main control board for refrigerant system port CN8 on inverter module.
2. Measure the resistance between each of U, V and W and each of P and N on the inverter module. All the resistances should be infinite. If any of them are not infinite, the inverter module is damaged and should be replaced.
3. The normal voltage between F0 and GND is 5V. Refer to Figure 4-4.6.
4. When replacing an inverter module, a layer of thermally conductive silica gel should be painted on the IPM module (on the reverse side of the inverter module PCB). Refer to Figure 4-4.2.

*Figure 4-4.6: F0 and GND voltage on IC28-1 (F0), IC28-4 (GND)*

## S-Therm Yukon split series

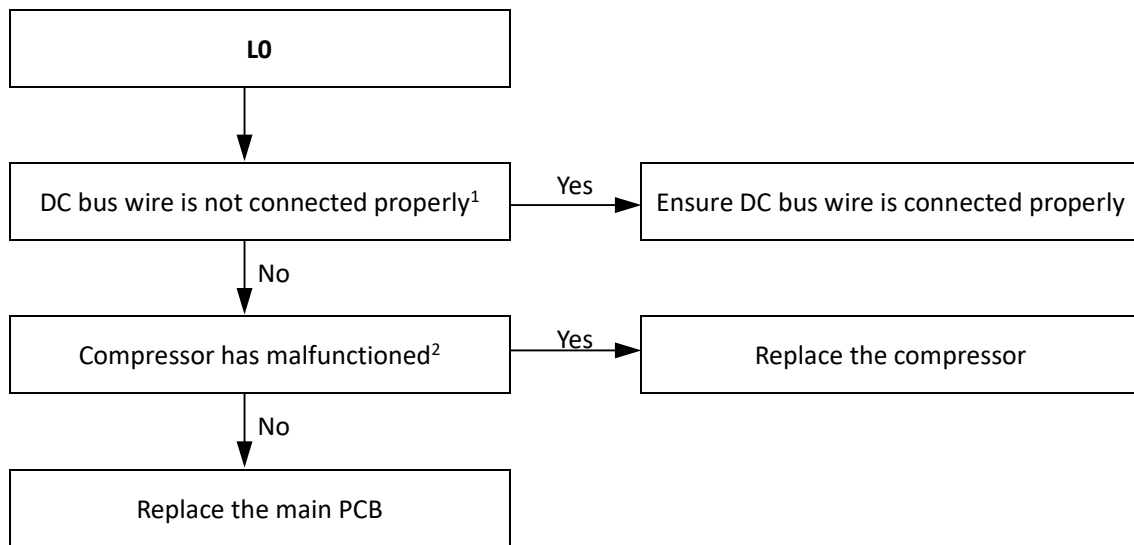
### Situation 2: L0 error appears immediately after the compressor starts up



Notes:

1. The DC bus wire should run from the N terminal on the inverter module, through the current sensor (in the direction indicated by the arrow on the current sensor), and end at the N terminal of capacitor. Refer to Figure 4-4.7.

Figure 4-4.7: DC bus wire connection (L1L2L3, PIN- POUT)

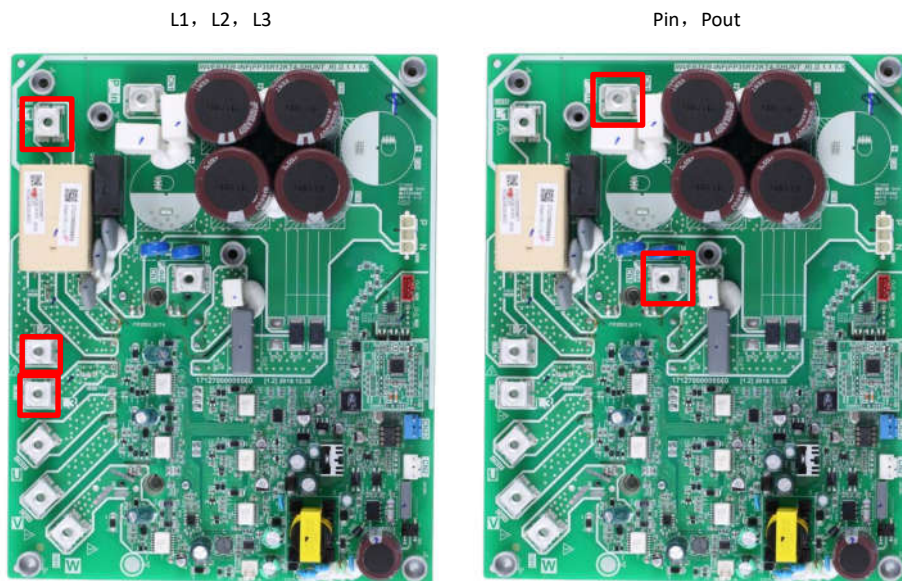

2. The normal resistances of the inverter compressor are 0.7-1.5Ω among U V W and infinite between each of U V W and ground. If any of the resistances differ from these specifications, the compressor has malfunctioned.

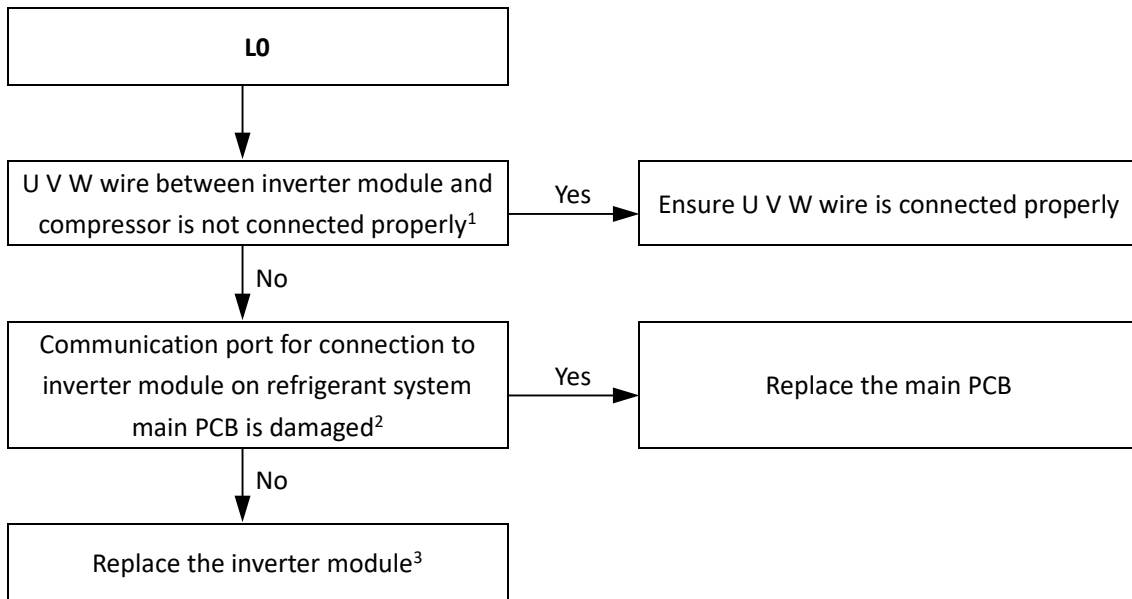
**Situation 3: L0 error appears within 2 seconds of compressor start-up**

**Notes:**

1. Connect the U V W wire from the inverter module to the correct compressor terminals, as indicated by the labels on the compressor.
2. Measure the voltage between each of W-, W+, V-, V+, U-, U+ and GND when the unit is in standby. The normal voltage should be 2.5V-4V and the six voltages should be same, otherwise the communication terminal has failed. Refer to Figure4-4.8.

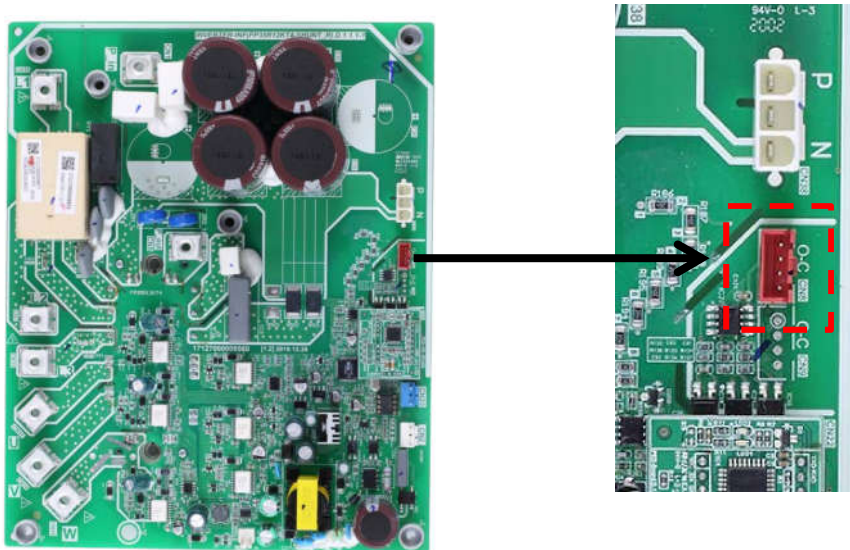
*Figure 4-4.8: Connection port for inverter module*



3. When replacing an inverter module, a layer of thermally conductive silica gel should be painted on the IPM module (on the reverse side of the inverter module PCB). Refer to Figure 4-4.2.

## S-Therm Yukon split series

**Condition 4: L0 error appears after the compressor has been running for a period of time and the compressor speed is over 60rps**

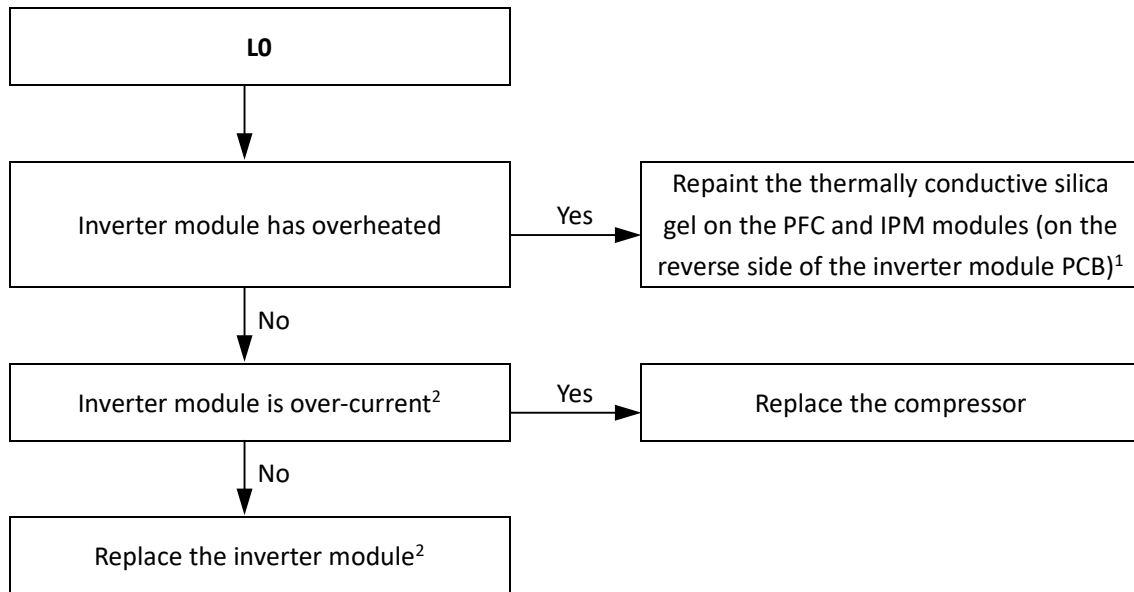

Notes:

1. When replacing an inverter module, a layer of thermally conductive silica gel should be painted on the IPM module (on the reverse side of the inverter module PCB).
2. Use clip-on ammeter to measure the compressor current, if the current is normal indicates the inverter module is failed, if the current is abnormal indicates the compressor has failed.

### Situation 5: L0 error appears occasionally/irregularly

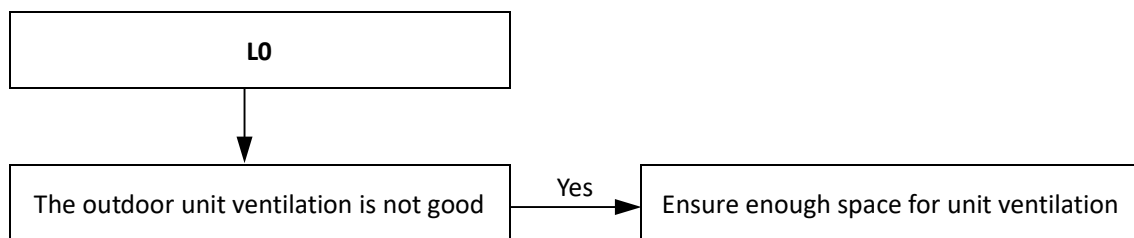

**4.21.7 L1/L2 troubleshooting**

The normal DC voltage between terminals P and N on inverter module is 540V. If the voltage is lower than 300V, the unit displays an L1 error; if the voltage is higher than 830V, the unit displays an L2 error. Refer to Figure4-4.9.

Figure 4-4.9: P, N terminals voltage

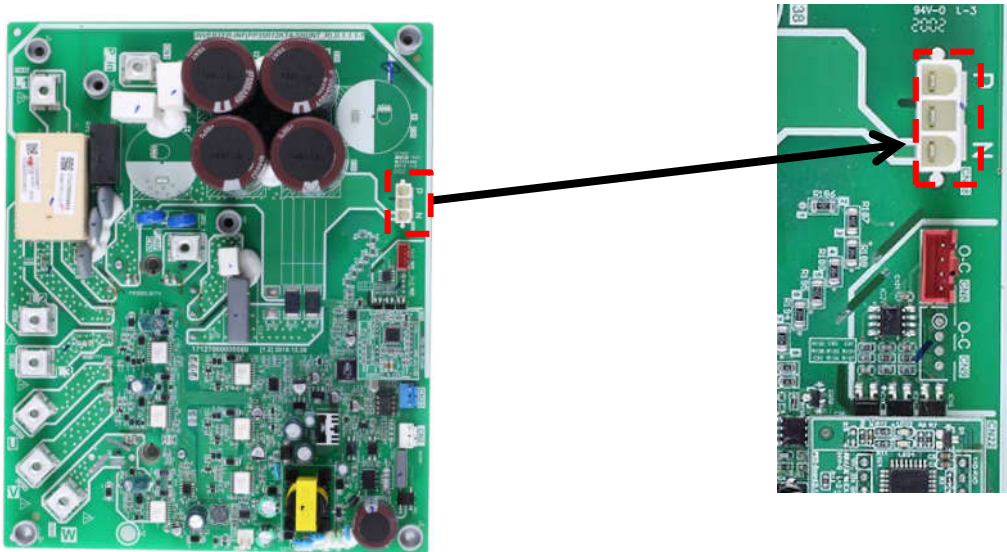

$V_{normal} = 540V DC$

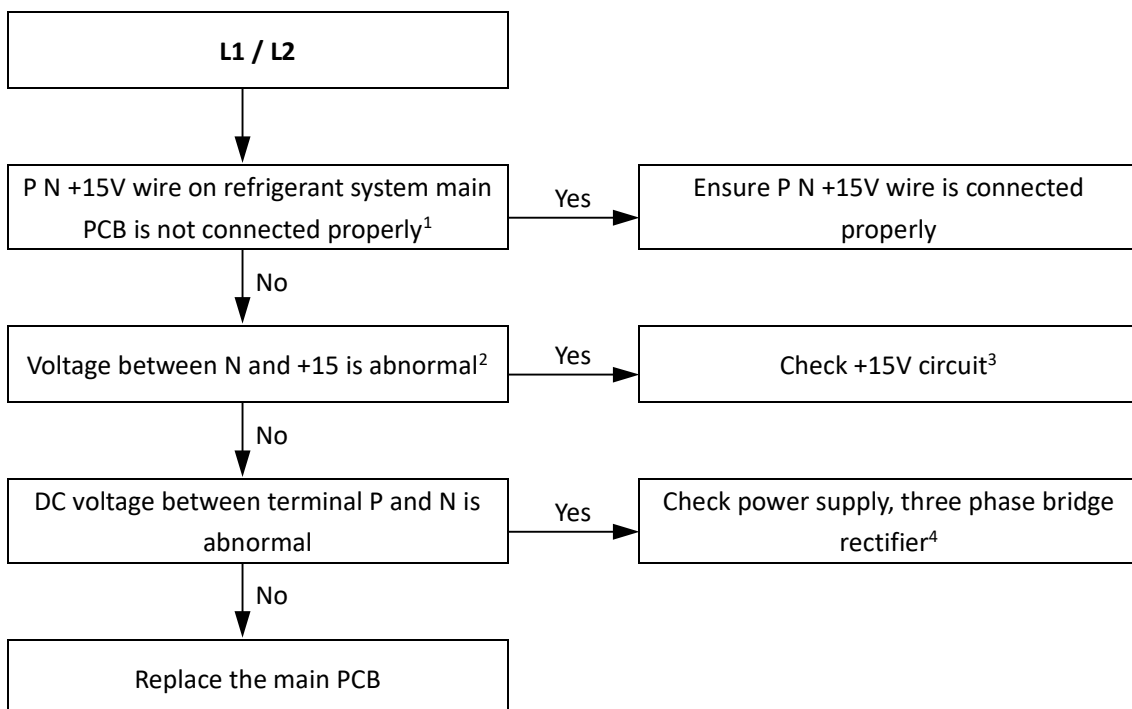
**Situation 1: L1 or L2 error appears immediately after the outdoor unit is powered-on**

**Notes:**

1. P N +15V terminal on refrigerant system main PCB. Refer to Figure4-4.9.
2. Voltage between N and +15. Refer to Figure4-4.10

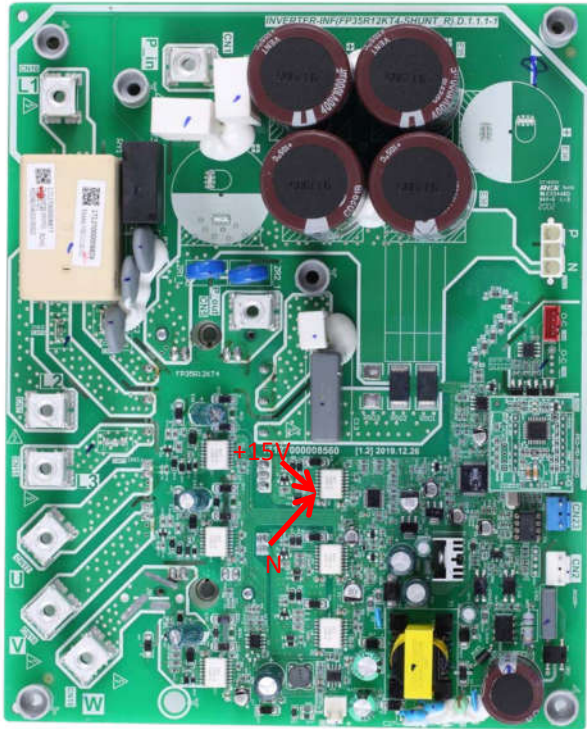
Figure 4-4.10: P N +15V terminal +15V (IC4/5/6 PIN12); N- (IC/4/5, 6) PIN13



3. Check the +15V circuit according to corresponding wiring diagram. If IC4/5/6 PIN12 on inverter module output voltage is not +15V means the inverter module is failed. If voltage output of inverter module is +15V means main PCB is failed.
4. Check the bridge rectifier using one of the following two methods (refer to Figure 4-4.11):
  - Method 1: measure the resistance between any two of the 5 bridge rectifier terminals. If any of the resistances is close to zero, the bridge rectifier has failed.
  - Method 2: dial a multimeter to the diode setting:
    - Put the red probe on the DC power output negative terminal (terminal 5) and put the black probe onto each of the AC power input terminals (terminals 1, 2 and 3) in turn. The voltage between terminal 5 and each of terminals 1, 2 and 3 should be around 0.378V. If the voltage is 0, the

bridge rectifier has failed.

- Put the red probe on the DC power output positive terminal (terminal 4), then put black probe onto each of the AC power input terminals (terminals 1, 2 and 3) in turn. The voltage between terminal 4 and each of terminals 1, 2 and 3 should be infinite. If the voltage is 0, the bridge rectifier has failed.

Figure 4-4.11: Bridge rectifier

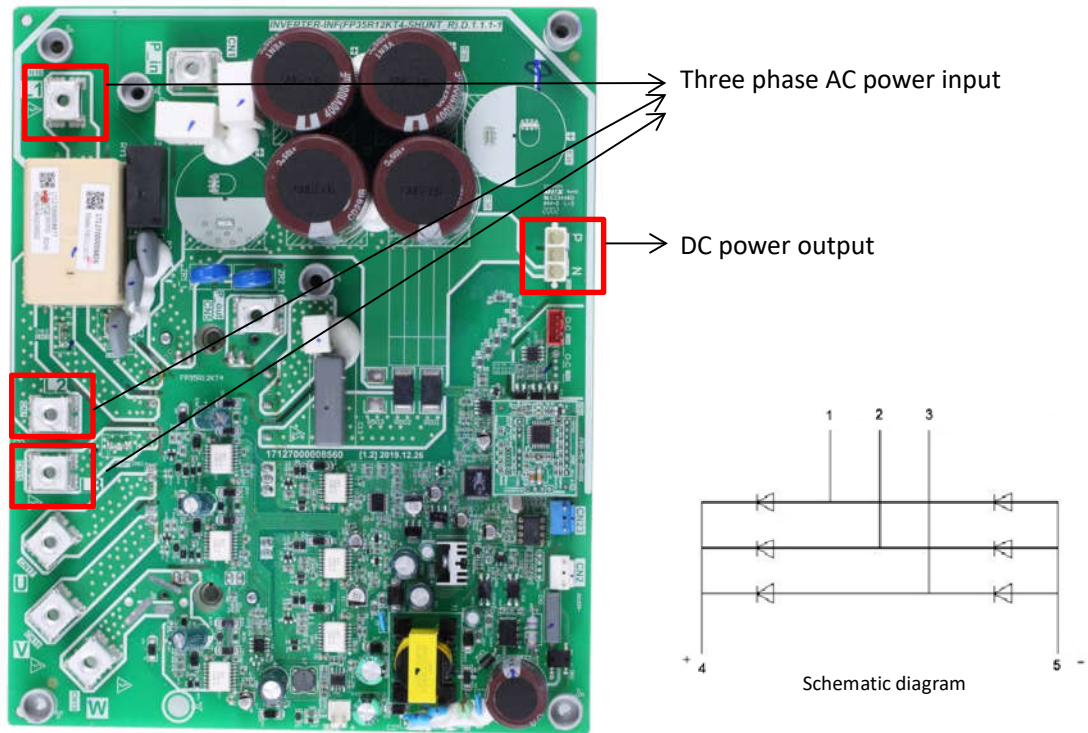

#### 4.21.8 L4 troubleshooting(the same as L1/L2)

**Situation 1: L4 error appears immediately after the outdoor unit is powered-on**

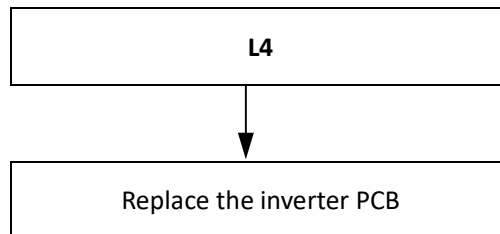

**Condition 2: L4 error appears after the compressor has been running for a period of time and the compressor speed is over 60rps**

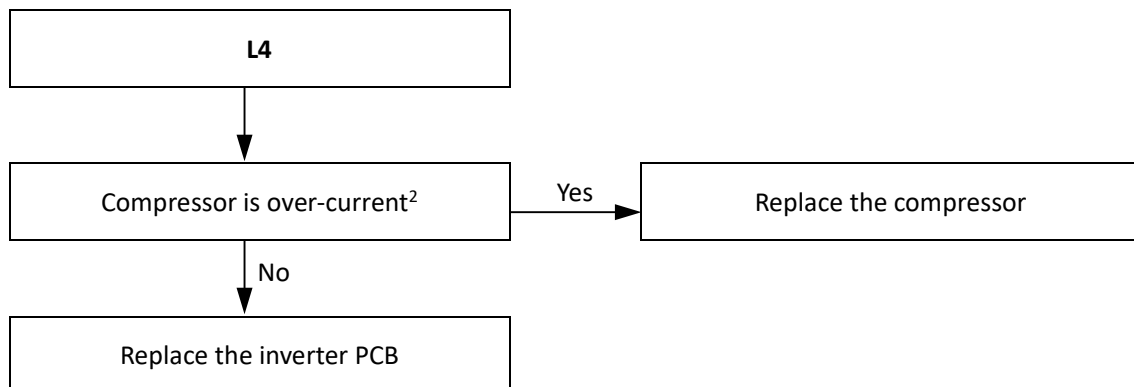

Notes:

- Re-start the unit, use clip-on ammeter to measure the compressor current, if the current is normal indicates the compressor is failed, if the current is abnormal indicates the inverter PCB is failed..

# S-Therm Yukon split series

## 4.21.9 L5/L8/L9 troubleshooting

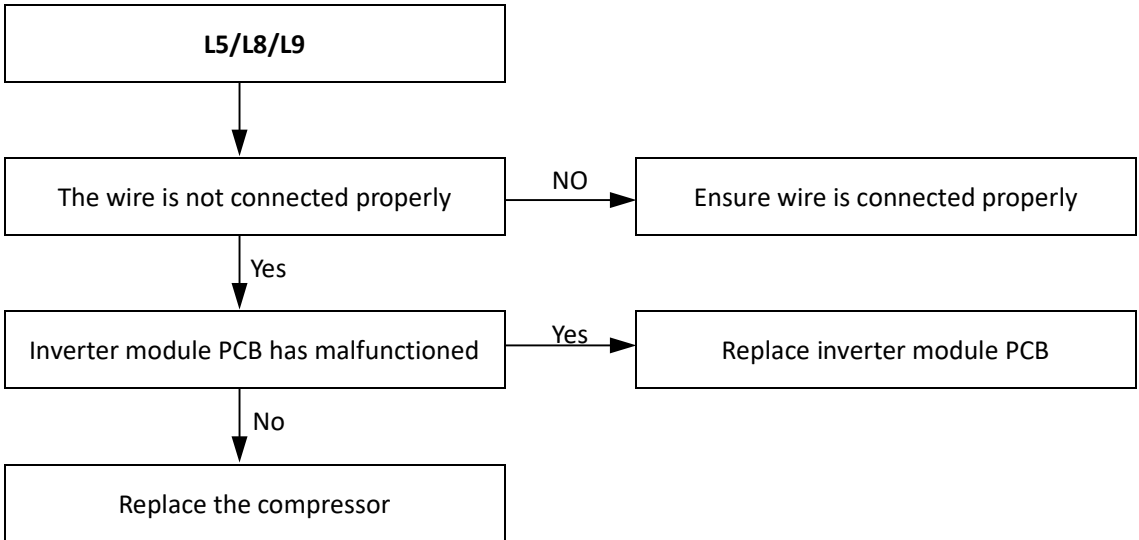

## 4.22 Pd Troubleshooting

### 4.22.1 Digital display output



### 4.22.2 Description

- High temperature protection of air side heat exchanger refrigerant outlet in cooling mode. When the air side heat exchanger refrigerant outlet temperature is higher than 61°C for more than 3 seconds, the system displays Pd protection and S-Therm Yukon stops running. When the air side heat exchanger refrigerant outlet temperature returns drops below 55°C, Pd is removed and normal operation resumes.
- S-Therm Yukon stops running.
- Error code is displayed on outdoor unit main PCB and user interface.

### 4.22.3 Possible causes

- Temperature sensor not connected properly or has malfunctioned.
- Poor condenser heat exchange.
- Fan motor damaged.
- Hydronic box main PCB damaged.

# S-Therm Yukon split series



## 4.22.4 Procedure

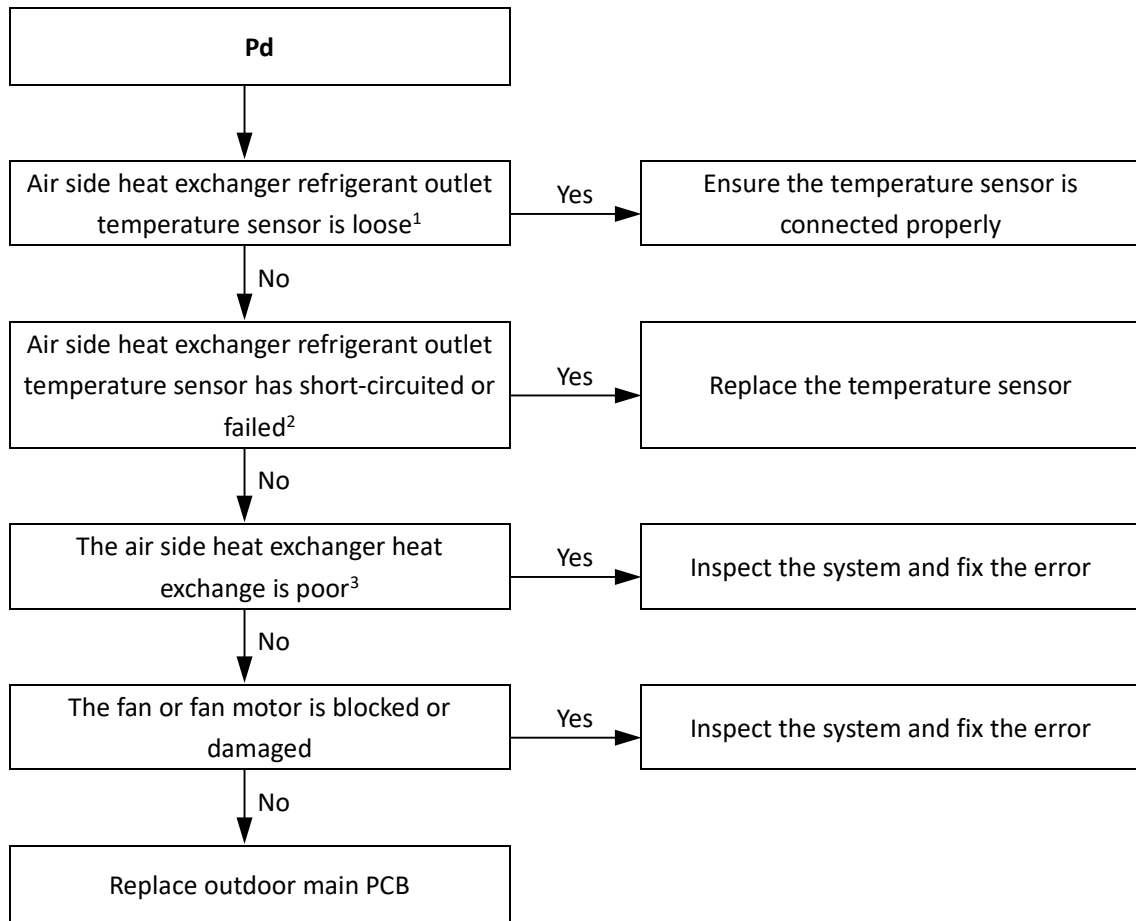

Notes:

1. Air side heat exchanger refrigerant outlet temperature sensor and outdoor ambient temperature sensor connection port are CN9 on the MSH-60EB; MSH-80EB; MSH-100EB outdoor unit refrigerant system main PCB (labeled 12 in Figure 4-2.2 in Part 4, 2.3 "Main PCB for Refrigerant System, Inverter Module"). port CN9 on the MSH-120EB; MSH-140EB; MSH-160EB outdoor unit refrigerant system main PCB (labeled 12 in Figure 4-2.3 in Part 4, 2. 3 "Main PCB for Refrigerant System, Inverter Module"), port CN9 on the MSH-120EB-3; MSH-140EB-3; MSH-160EB-3 outdoor unit refrigerant system main PCB (labeled 17 in Figure 4-2.4 in Part 4, 2. 3 "Main PCB for Refrigerant System, Inverter Module")
2. Measure sensor resistance. If the resistance is too low, the sensor has short-circuited. If the resistance is not consistent with the sensor's resistance characteristics table, the sensor has failed. Refer to Part 2, 1.1 "Outdoor Unit Layout" and to Table 4-5.1 in Part 4, 5.1 "Temperature Sensor Resistance Characteristics".
3. Check air side heat exchanger, fan and air outlets for dirt/blockages.
4. High pressure switch connection is port CN13 on the

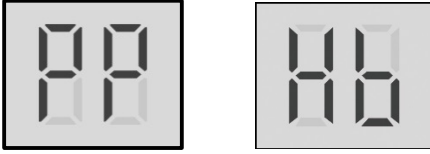
**4.23 PP Troubleshooting****4.23.1 Digital display output****4.23.2 Description**

- Water side heat exchanger inlet temperature is higher than outlet temperature in heating mode.
- S-Therm Yukon stops running.
- Error code is displayed on hydronic box main PCB and user interface.
- Hb indicates PP has displayed 3 times.

**4.23.3 Possible causes**

- Temperature sensor not connected properly or has malfunctioned.
- 4-way valve is blocked or damaged.
- Hydronic box main PCB damaged.

# S-Therm Yukon split series

## 4.23.4 Procedure

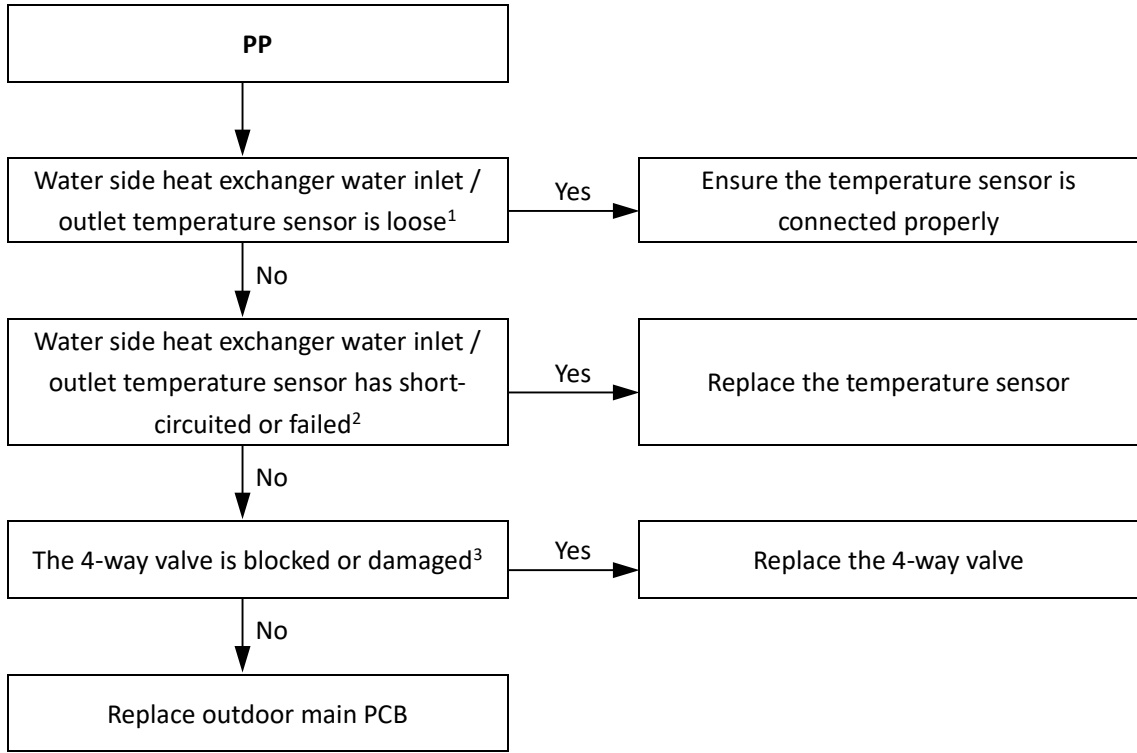

Notes:

1. Water side heat exchanger water inlet temperature sensor and water side heat exchanger water outlet temperature sensor connections are port CN6 on the hydronic box main PCB (labeled 10 in Figure 4-2.1 in Part 4, 2.2 "Main PCB for Hydronic System").
2. Measure sensor resistance. If the resistance is too low, the sensor has short-circuited. If the resistance is not consistent with the sensor's resistance characteristics table, the sensor has failed. Refer to Part 2, 1.2 "Hydronic Box Layout" and to Table 4-5.3 in Part 4, 5.1 "Temperature Sensor Resistance Characteristics".
3. Restart the unit in cooling mode to change the refrigerant flow direction. If the unit does not operate normally, the 4-way valve is blocked or damaged.

## 4.24 C7 Troubleshooting

### 4.24.1 Digital display output

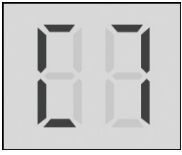

### 4.24.2 Description

- Transducer module temperature too high protection
- S-Therm Yukon stops running.
- Error code is displayed on hydronic box main PCB and user interface.

### 4.24.3 Possible causes

- Power supply voltage of the unit is low.
- The space between the units is too narrow for heat exchanger.
- Heat exchanger is dirty or something is block on the surface.
- Fan is not running.
- Water flow rate is low.
- Water outlet temp. sensor is loosen or broken.

# S-Therm Yukon split series



## 4.24.4 Procedure

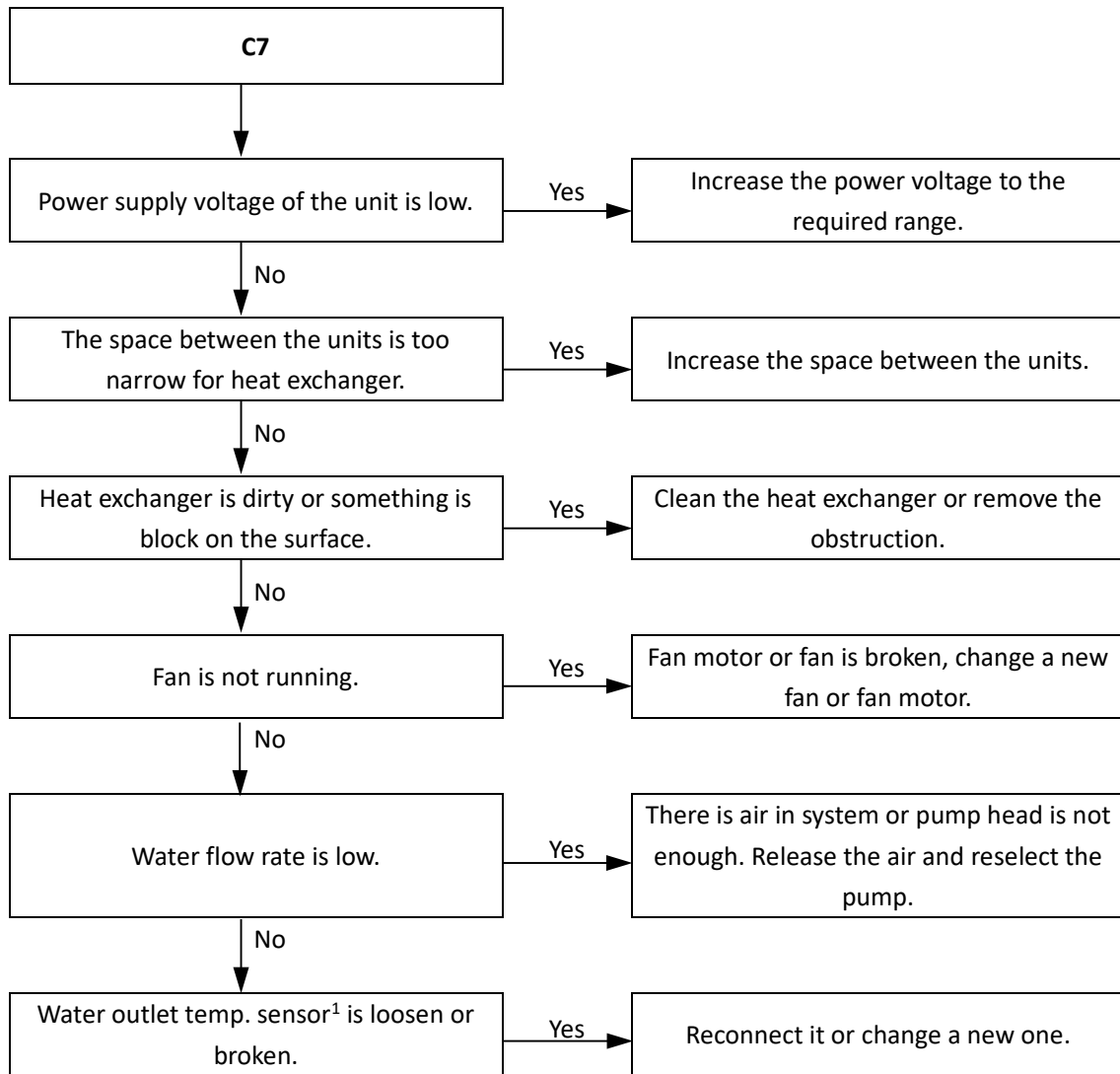

Notes:

1. Water side heat exchanger water inlet temperature sensor and water side heat exchanger water outlet temperature sensor connections are port CN6 on the hydronic box main PCB (labeled 10 in Figure 4-2.1 in Part4, 2.2 "Main PCB for Hydronic System").
2. Measure sensor resistance. If the resistance is too low, the sensor has short-circuited. If the resistance is not consistent with the sensor's resistance characteristics table, the sensor has failed. Refer to Part 2, 1.2 "Hydronic Box Layout" and to Table 4-5.3 in Part 4, 5.1 "Temperature Sensor Resistance Characteristics".

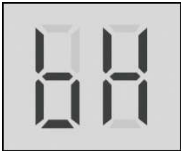
**4.25 bH Troubleshooting****4.25.1 Digital display output****4.25.2 Description**

- PED PCB failure
- S-Therm Yukon stops running.
- Error code is displayed on hydronic box main PCB and user interface.

**4.25.3 Possible causes**

- Power supply problem.
- PED board broken.
- IPM module broken.

# S-Therm Yukon split series



## 4.25.4 Procedure

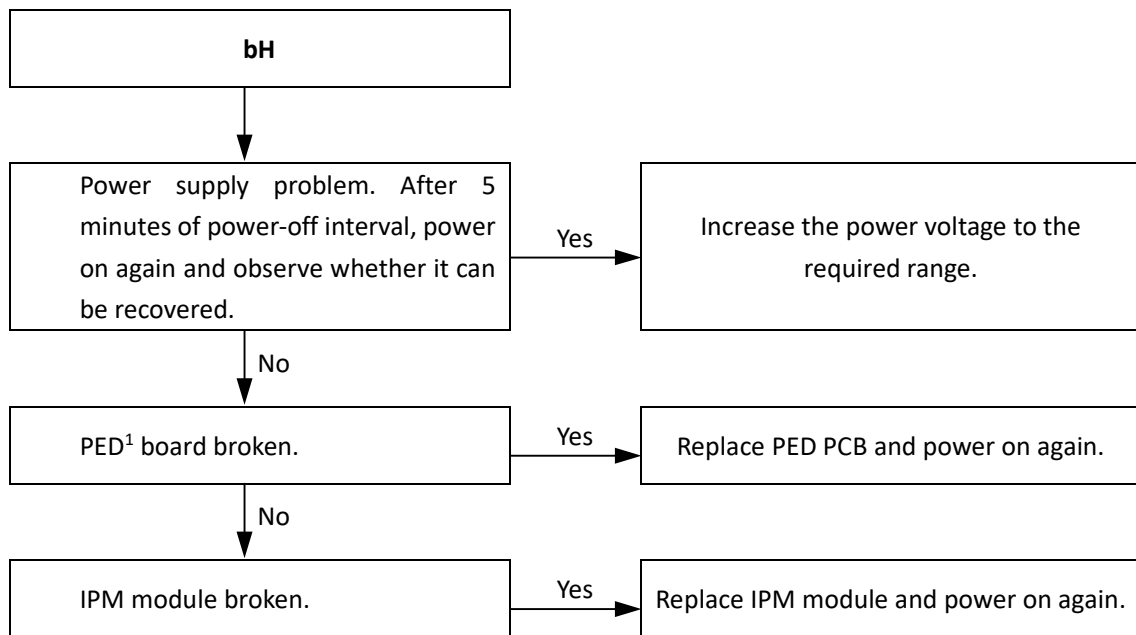

Notes:

1. PED is port CN22 on the hydronic box main PCB (labeled 11 in Figure 4-2.7: MSH-120EB-3; MSH-140EB-3; MSH-160EB-3 outdoor unit inverter module ).

## 4.26 Pb Troubleshooting

### 4.26.1 Digital display output



### 4.26.2 Description

- Water side heat exchanger anti-freeze protection.
- S-Therm Yukon stops running.
- Error code is displayed on hydronic box main PCB and **ANTI.FREEZE** icon is displayed on user interface.

### 4.26.3 Possible causes

- Normal system protection.
- Temperature sensor not connected properly or has malfunctioned.
- Hydronic box main PCB damaged.

### 4.26.4 Procedure

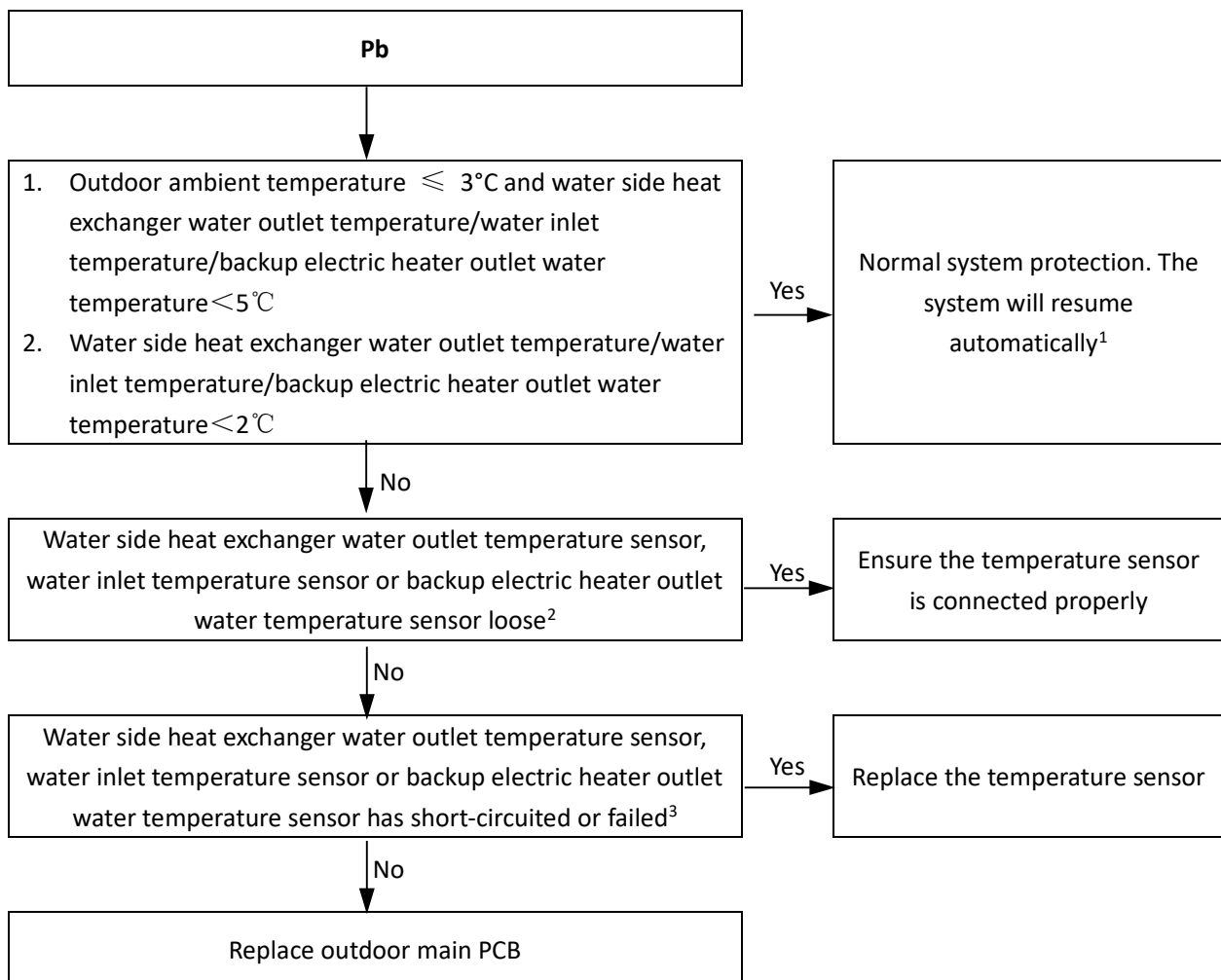

#### Notes:

- Refer to Part 3, 5.7 "Water Side Heat Exchanger Anti-freeze Protection Control".
- Final outlet water temperature sensor, water side heat exchanger water inlet temperature sensor and water side heat exchanger water outlet temperature sensor connections are port CN6 on the hydronic box main PCB (labeled 10 in Figure 4-2.1 in Part4, 2.2 "Main PCB for Hydronic System").
- Measure sensor resistance. If the resistance is too low, the sensor has short-circuited. If the resistance is not consistent with the sensor's resistance characteristics table, the sensor has failed. Refer to Part 2, 1.2 "Hydronic Box Layout" and to Table 4-5.3 in Part 4, 5.1 "Temperature Sensor Resistance Characteristics".

5 Appendix to Part 4

5.1 Temperature Sensor Resistance Characteristics

Table 4-5.1: Outdoor ambient temperature sensor, water side heat exchanger refrigerant inlet / outlet (liquid / gas pipe) temperature sensor, air side heat exchanger refrigerant out temperature sensor and suction pipe temperature sensor resistance characteristics

Temperature (°C)	Resistance (kΩ)	Temperature (°C)	Resistance (kΩ)	Temperature (°C)	Resistance (kΩ)	Temperature (°C)	Resistance (kΩ)
-25	144.266	15	16.079	55	2.841	95	0.708
-24	135.601	16	15.313	56	2.734	96	0.686
-23	127.507	17	14.588	57	2.632	97	0.666
-22	119.941	18	13.902	58	2.534	98	0.646
-21	112.867	19	13.251	59	2.44	99	0.627
-20	106.732	20	12.635	60	2.35	100	0.609
-19	100.552	21	12.05	61	2.264	101	0.591
-18	94.769	22	11.496	62	2.181	102	0.574
-17	89.353	23	10.971	63	2.102	103	0.558
-16	84.278	24	10.473	64	2.026	104	0.542
-15	79.521	25	10	65	1.953	105	0.527
-14	75.059	26	9.551	66	1.883		
-13	70.873	27	9.125	67	1.816		
-12	66.943	28	8.721	68	1.752		
-11	63.252	29	8.337	69	1.69		
-10	59.784	30	7.972	70	1.631		
-9	56.524	31	7.625	71	1.574		
-8	53.458	32	7.296	72	1.519		
-7	50.575	33	6.982	73	1.466		
-6	47.862	34	6.684	74	1.416		
-5	45.308	35	6.401	75	1.367		
-4	42.903	36	6.131	76	1.321		
-3	40.638	37	5.874	77	1.276		
-2	38.504	38	5.63	78	1.233		
-1	36.492	39	5.397	79	1.191		
0	34.596	40	5.175	80	1.151		
1	32.807	41	4.964	81	1.113		
2	31.12	42	4.763	82	1.076		
3	29.528	43	4.571	83	1.041		
4	28.026	44	4.387	84	1.007		
5	26.608	45	4.213	85	0.974		
6	25.268	46	4.046	86	0.942		
7	24.003	47	3.887	87	0.912		
8	22.808	48	3.735	88	0.883		
9	21.678	49	3.59	89	0.855		
10	20.61	50	3.451	90	0.828		
11	19.601	51	3.318	91	0.802		
12	18.646	52	3.191	92	0.777		
13	17.743	53	3.069	93	0.753		

14	16.888	54	2.952	94	0.73		
----	--------	----	-------	----	------	--	--

*Table 4-5.2: Compressor discharge pipe temperature sensor resistance characteristics*

Temperature (°C)	Resistance (kΩ)	Temperature (°C)	Resistance (kΩ)	Temperature (°C)	Resistance (kΩ)	Temperature (°C)	Resistance (kΩ)
-20	542.7	20	68.66	60	13.59	100	3.702
-19	511.9	21	65.62	61	13.11	101	3.595
-18	483.0	22	62.73	62	12.65	102	3.492
-17	455.9	23	59.98	63	12.21	103	3.392
-16	430.5	24	57.37	64	11.79	104	3.296
-15	406.7	25	54.89	65	11.38	105	3.203
-14	384.3	26	52.53	66	10.99	106	3.113
-13	363.3	27	50.28	67	10.61	107	3.025
-12	343.6	28	48.14	68	10.25	108	2.941
-11	325.1	29	46.11	69	9.902	109	2.860
-10	307.7	30	44.17	70	9.569	110	2.781
-9	291.3	31	42.33	71	9.248	111	2.704
-8	275.9	32	40.57	72	8.940	112	2.630
-7	261.4	33	38.89	73	8.643	113	2.559
-6	247.8	34	37.30	74	8.358	114	2.489
-5	234.9	35	35.78	75	8.084	115	2.422
-4	222.8	36	34.32	76	7.820	116	2.357
-3	211.4	37	32.94	77	7.566	117	2.294
-2	200.7	38	31.62	78	7.321	118	2.233
-1	190.5	39	30.36	79	7.086	119	2.174
0	180.9	40	29.15	80	6.859	120	2.117
1	171.9	41	28.00	81	6.641	121	2.061
2	163.3	42	26.90	82	6.430	122	2.007
3	155.2	43	25.86	83	6.228	123	1.955
4	147.6	44	24.85	84	6.033	124	1.905
5	140.4	45	23.89	85	5.844	125	1.856
6	133.5	46	22.89	86	5.663	126	1.808
7	127.1	47	22.10	87	5.488	127	1.762
8	121.0	48	21.26	88	5.320	128	1.717
9	115.2	49	20.46	89	5.157	129	1.674
10	109.8	50	19.69	90	5.000	130	1.632
11	104.6	51	18.96	91	4.849		
12	99.69	52	18.26	92	4.703		
13	95.05	53	17.58	93	4.562		
14	90.66	54	16.94	94	4.426		
15	86.49	55	16.32	95	4.294		
16	82.54	56	15.73	96	4.167		
17	78.79	57	15.16	97	4.045		
18	75.24	58	14.62	98	3.927		
19	71.86	59	14.09	99	3.812		

Table 4-5.3: Water side heat exchanger water inlet / outlet temperature sensor, final outlet water temperature sensor and DHW temperature sensor resistance characteristics

Temperature (°C)	Resistance (kΩ)	Temperature (°C)	Resistance (kΩ)	Temperature (°C)	Resistance (kΩ)	Temperature (°C)	Resistance (kΩ)
-30	867.29	10	98.227	50	17.600	90	4.4381
-29	815.80	11	93.634	51	16.943	91	4.3022
-28	767.68	12	89.278	52	16.315	92	4.1711
-27	722.68	13	85.146	53	15.713	93	4.0446
-26	680.54	14	81.225	54	15.136	94	3.9225
-25	641.07	15	77.504	55	14.583	95	3.8046
-24	604.08	16	73.972	56	14.054	96	3.6908
-23	569.39	17	70.619	57	13.546	97	3.5810
-22	536.85	18	67.434	58	13.059	98	3.4748
-21	506.33	19	64.409	59	12.592	99	3.3724
-20	477.69	20	61.535	60	12.144	100	3.2734
-19	450.81	21	58.804	61	11.715	101	3.1777
-18	425.59	22	56.209	62	11.302	102	3.0853
-17	401.91	23	53.742	63	10.906	103	2.9960
-16	379.69	24	51.396	64	10.526	104	2.9096
-15	358.83	25	49.165	65	10.161	105	2.8262
-14	339.24	26	47.043	66	9.8105		
-13	320.85	27	45.025	67	9.4736		
-12	303.56	28	43.104	68	9.1498		
-11	287.33	29	41.276	69	8.8387		
-10	272.06	30	39.535	70	8.5396		
-9	257.71	31	37.878	71	8.2520		
-8	244.21	32	36.299	72	7.9755		
-7	231.51	33	34.796	73	7.7094		
-6	219.55	34	33.363	74	7.4536		
-5	208.28	35	31.977	75	7.2073		
-4	197.67	36	30.695	76	6.9704		
-3	187.66	37	29.453	77	6.7423		
-2	178.22	38	28.269	78	6.5228		
-1	168.31	39	27.139	79	6.3114		
0	160.90	40	26.061	80	6.1078		
1	152.96	41	25.031	81	5.9117		
2	145.45	42	24.048	82	5.7228		
3	138.35	43	23.109	83	5.5409		
4	131.64	44	22.212	84	5.3655		
5	125.28	45	21.355	85	5.1965		
6	119.27	46	20.536	86	5.0336		
7	113.58	47	19.752	87	4.8765		
8	108.18	48	19.003	88	4.7251		
9	103.07	49	18.286	89	4.5790		

# Part 5

## General Information

<b>1 S-Therm Yukon System .....</b>	<b>114</b>
<b>2 Unit Capacities .....</b>	<b>116</b>
<b>3 System Design and Unit Selection .....</b>	<b>117</b>
<b>4 Typical Applications .....</b>	<b>120</b>

# S-Therm Yukon split series

## 1 S-Therm Yukon System

### 1.1 System Schematic

Figure 1-1.1: System schematic

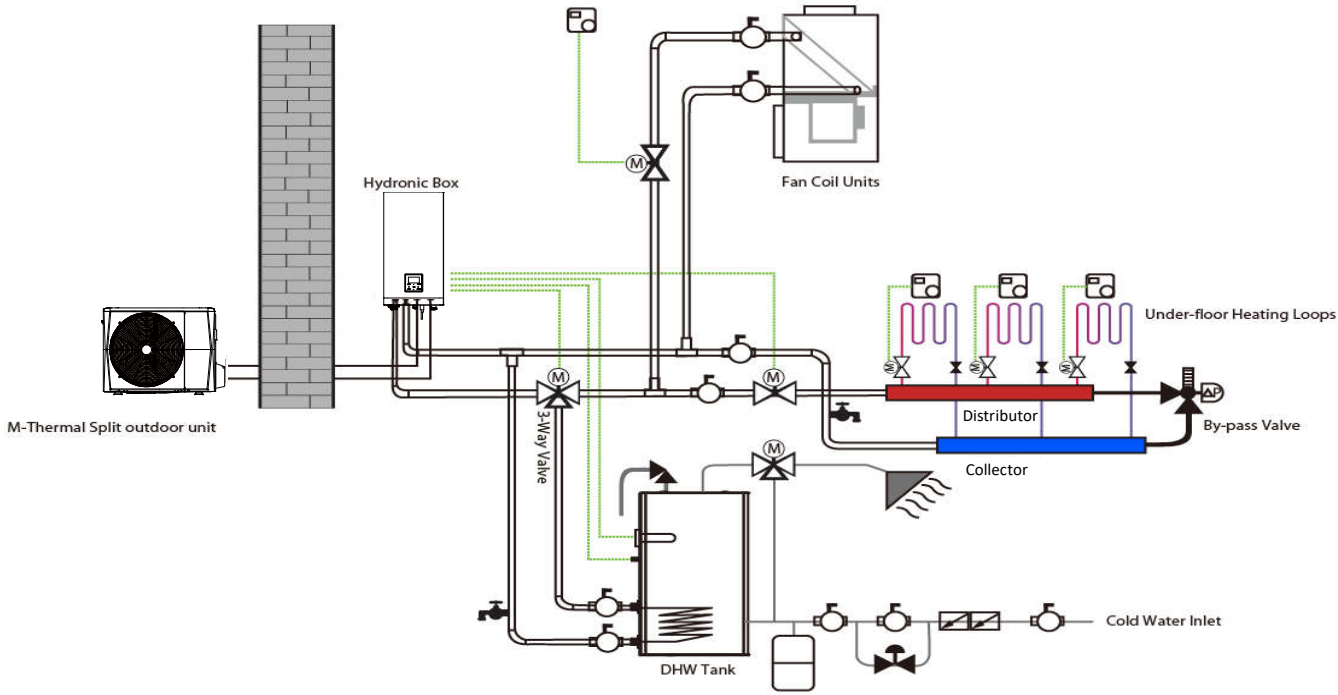

M thermal is an integrated air-to-water heat pump system which is one-stop solution for space heating, space cooling and domestic hot water. The outdoor heat pump system extracts heat from the outdoor air and transfers this heat through refrigerant piping to the plate heat exchanger in the hydronic box. The heated water in the hydronic box circulates to low temperature heat emitters (under-floor heating loops or low temperature radiators) to provide space heating, and to the domestic hot water tank to provide domestic hot water. The 4-way valve in the outdoor unit can reverse the refrigerant cycle so that the hydronic box can provide chilled water for cooling using fan coil units.

The heating capacity of heat pumps decreases with ambient temperature dropping. Backup electric heater is customized to provide additional heating capacity for use during extremely cold weather when the heat pump capacity is insufficient.

## 1.2 System Configurations

S-Therm Yukon can be configured to run with the electric heater either enabled or disabled and can also be used in conjunction with an auxiliary heat source such as a boiler.

The chosen configuration affects the size of heat pump that is required. Three typical configurations are described below. Refer to Figure 1-1.2.

### Configuration 1: Heat pump only

- The heat pump covers the required capacity and no extra heating capacity is necessary.
- Requires selection of larger capacity heat pump and implies higher initial investment.
- Ideal for new construction in projects where energy efficiency is paramount.

### Configuration 2: Heat pump and backup electric heater

- Heat pump covers the required capacity until the ambient temperature drops below the point at which the heat pump is able to provide sufficient capacity. When the ambient temperature is below this equilibrium point (as shown in Figure 1-1.2, the backup electric heater supplies the required additional heating capacity.
- Best balance between initial investment and running costs, results in lowest lifecycle cost.
- Ideal for new construction.

### Configuration 3: Heat pump conjunction with auxiliary heat source

- Heat pump covers the required capacity until the ambient temperature drops below the point at which the heat pump is able to provide sufficient capacity. When the ambient temperature is below this equilibrium point (as shown in Figure 1-1.2, depending on the system settings, either the auxiliary heat source supplies the required additional heating capacity or the heat pump does not run and the auxiliary heat source covers the required capacity.
- Enables selection of lower capacity heat pump.
- Ideal for refurbishments and upgrades.

Figure 1-1.2: System configurations

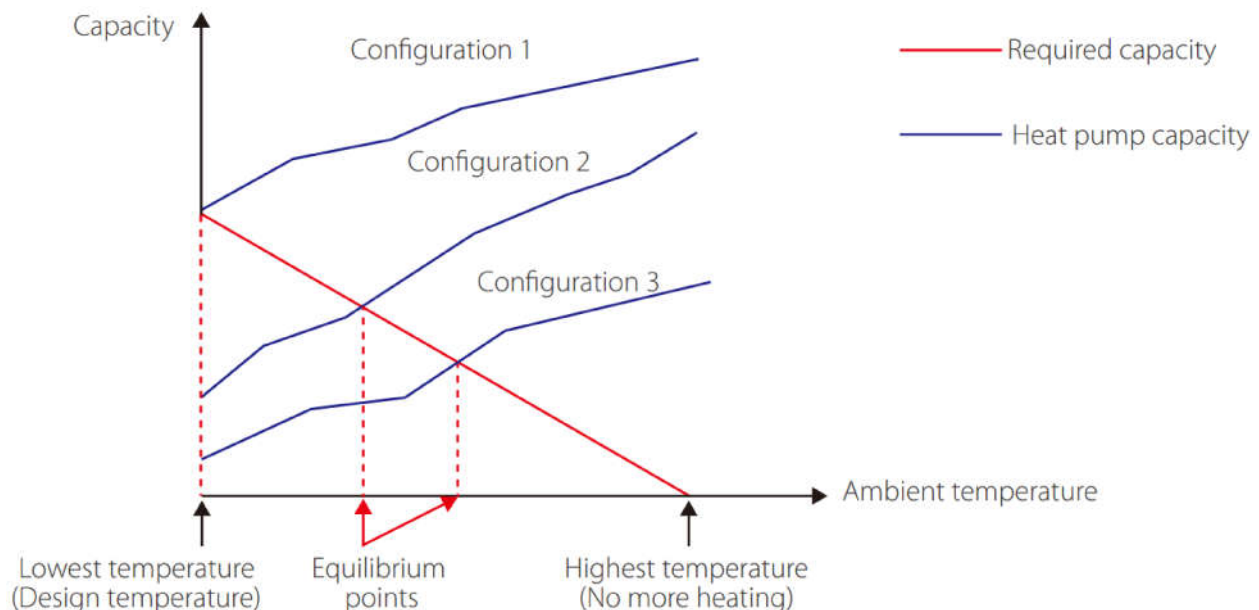

# S-Therm Yukon split series



## 2 Unit Capacities

### 2.1 Outdoor unit

Table 1-2.1: Outdoor unit

Capacity	4kW	6kW
	MSH-40EB	MSH-60EB
Power Supply (V/Ph/Hz)	220-240/1 /50	220-240/1 /50
Appearance		

Capacity	8kW	10kW	12kW		14kW		16kW	
Model	MSH-80EB	MSH-100EB	MSH-120EB	MSH-120EB-3	MSH-140EB	MSH-140EB-3	MSH-160EB	MSH-160EB-3
Power Supply (V/Ph/Hz)	220-240/1/50	220-240/1/50	220-240/1/50	380-415/3/50	220-240/1/50	380-415/3/50	220-240/1/50	380-415/3/50
Appearance								

### 2.2 Hydronic box

Table 1-2.2: Hydronic box

Model	MSH-60IB MSH-60IB/3	MSH-100IB MSH-100IB/3 MSH-100IB-3/9	MSH-160IB MSH-160IB/3 MSH-160IB-3/9
Power Supply (V/Ph/Hz)	220-240/1 /50	220-240/1 /50	220-240/1 /50
Compatible outdoor unit model	MSH-40EB	MSH-80EB	MSH-120EB
			MSH-140EB
			MSH-160EB
	MSH-60EB	MSH-80EB	MSH-120EB-3
			MSH-140EB-3
			MSH-160EB-3



### 3 System Design and Unit Selection

#### 3.1 Selection procedure

##### Step 1: Total heat load calculation

Calculate conditioned surface area  
Select the heat emitters (type, quantity, water temperature and heat load)

##### Step 2: System configuration

Decide whether to include AHS and set AHS's switching temperature  
Decide whether backup electric heater is enabled or disabled

##### Step 3: Selection of outdoor units

Determine required total heat load on outdoor units  
Set capacity safety factor  
Select power supply

Provisionally select S-Therm Yukon unit capacity based on nominal capacity

Correct capacity of the outdoor units for the following items:  
Outdoor air temperature / Outdoor humidity / Water outlet temperature<sup>1</sup>  
/ Altitude / Anti-freeze fluid

Is corrected S-Therm Yukon unit capacity  $\geq$  Required total heat load on outdoor units<sup>2</sup>

Yes

S-Therm Yukon system selection is complete

No

Select a larger model or enable backup electric heater operation

## S-Therm Yukon split series

1. If the required water temperatures of the heat emitters are not all the same, the S-Therm Yukon's outlet water temperature setting should be set at the highest of the heat emitter required water temperatures. If the water outlet design temperature falls between two temperatures listed in the outdoor unit's capacity table, calculate the corrected capacity by interpolation.
2. If the outdoor unit selection is to be based on total heating load and total cooling load, select Split units which satisfy both total heating and cooling load requirements.

### 3.2 M thermal Leaving Water Temperature (LWT) Selection

The recommended design LWT ranges for different types of heat emitter are:

- For floor heating: 30 to 35°C
- For fan coil units: 30 to 45°C
- For low temperature radiators: 40 to 50°C

### 3.3 Optimizing System Design

To get the most comfort with the lowest energy consumption with M thermal, it is important to take account of the following considerations:

- Choose heat emitters that allow the heat pump system to operate at as low a hot water temperature as possible whilst still providing sufficient heating.
- Make sure the correct weather dependency curve is selected to match the installation environment (building structure, climate) as well as ender user's demands.
- Connecting room thermostats (field supplied) to the hydronic system helps prevent excessive space heating by stopping the outdoor unit and circulator pump when the room temperature is above the thermostat set point.

### 3.4 Tank back up heater notice

Heat pump will stop when T5(tank temperature) has reached the minimum of both T5S(tank setting temperature) and T5stop (highest tank temperature which can be reached under certain ambient temperature with heat pump only) and lasted for 5s. The value of T5stop is shown as below.

If T5S is higher than T5stop, then T5S can not be reached with heat pump only. In this case, tank back up heater is needed in order to reach T5S.

#### T5stop value:

Ambient temperature(°C)	< -20	-20~15	-15~-10	-10~-5	-5~0	0~5	5~10
T5stop(°C)	35	40	45	48	52	55	56
Ambient temperature(°C)	10~15	15~20	20~25	25~30	35~40	40~65	40~65
T5stop(°C)	57	56	55	52	50	48	45

# S-Therm Yukon split series

## 4 Typical Applications

### 4.1 Space Heating Only

The room thermostat is used as a switch. When there is a heating request from the room thermostat, the unit operates to achieve the target water temperature set on the user interface. When the room temperature reaches the thermostat’s set temperature, the unit stops.

Figure 1-5.1: Space heating

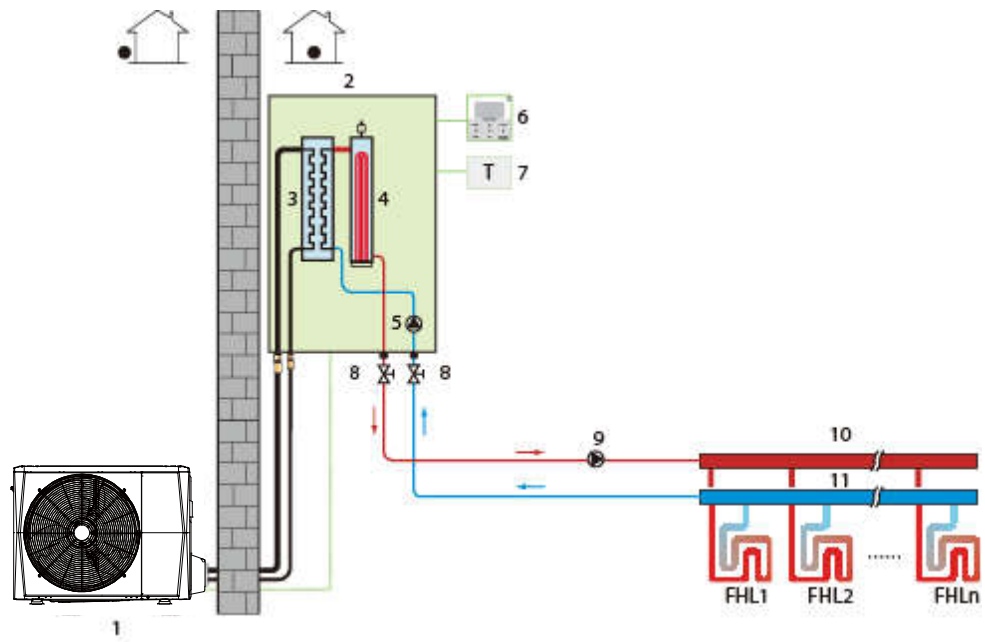

Legend			
1	Outdoor unit	7	Room thermostat (field supplied)
2	Hydronic box	8	Stop valve (field supplied)
3	Plate heat exchanger	9	External circulator pump (field supplied)
4	Backup electric heater(optional)	10	Distributor (field supplied)
5	Internal circulator pump	11	Collector (field supplied)
6	User interface	FHL 1...n	Floor heating loops (field supplied)

### 4.2 Space Heating and Domestic Hot Water

The room thermostats are not connected to the hydronic box but to a motorized valve. Each room's temperature is regulated by the motorized valve on its water circuit. Domestic hot water is supplied from the domestic hot water tank connected to the hydronic box. A bypass valve is required.

Figure 1-5.2: Space heating and domestic hot water

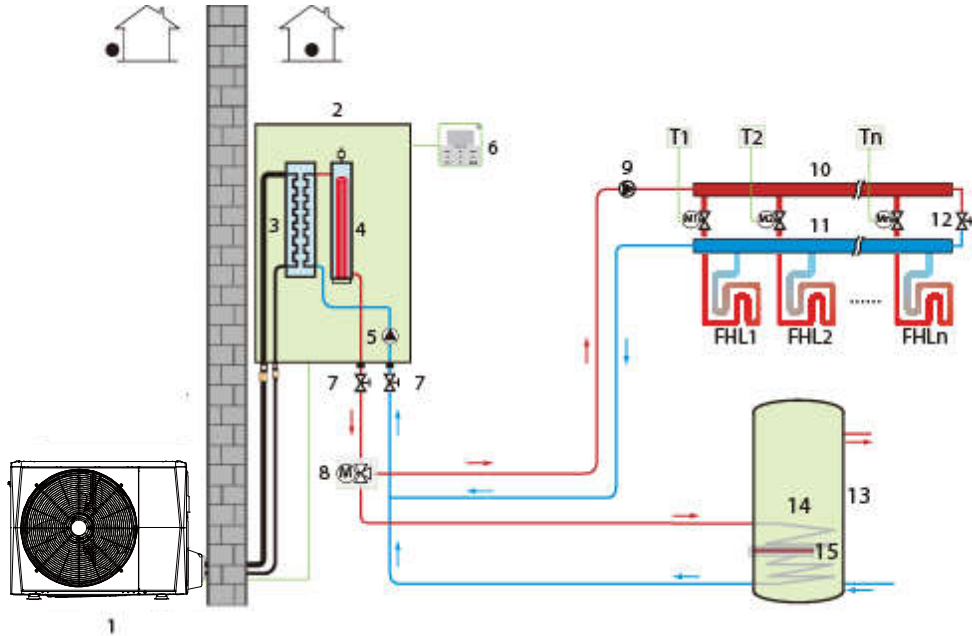

Legend			
1	Outdoor unit	10	Distributor (field supplied)
2	Hydronic box	11	Collector (field supplied)
3	Plate heat exchanger	12	Bypass valve (field supplied)
4	Backup electric heater(optional)	13	Domestic hot water tank (field supplied)
5	Internal circulator pump	14	Heat exchanger coil
6	User interface	15	Immersion heater
7	Stop valve (field supplied)	FHL 1...n	Floor heating loops (field supplied)
8	Motorized 3-way valve (field supplied)	M1...n	Motorized valves (field supplied)
9	External circulator pump (field supplied)	T1...n	Room thermostats (field supplied)

## S-Therm Yukon split series

### 4.3 Space Heating, Space Cooling and Domestic Hot Water

Floor heating loops and fan coil units are used for space heating and fan coil units are used for space cooling. Domestic hot water is supplied from the domestic hot water tank connected to the hydronic box. The unit switches to heating or cooling mode according to the temperature detected by the room thermostat. In space cooling mode, the 2-way valve is closed to prevent cold water entering the floor heating loops.

Figure 1-5.3: Space heating, space cooling and domestic hot water

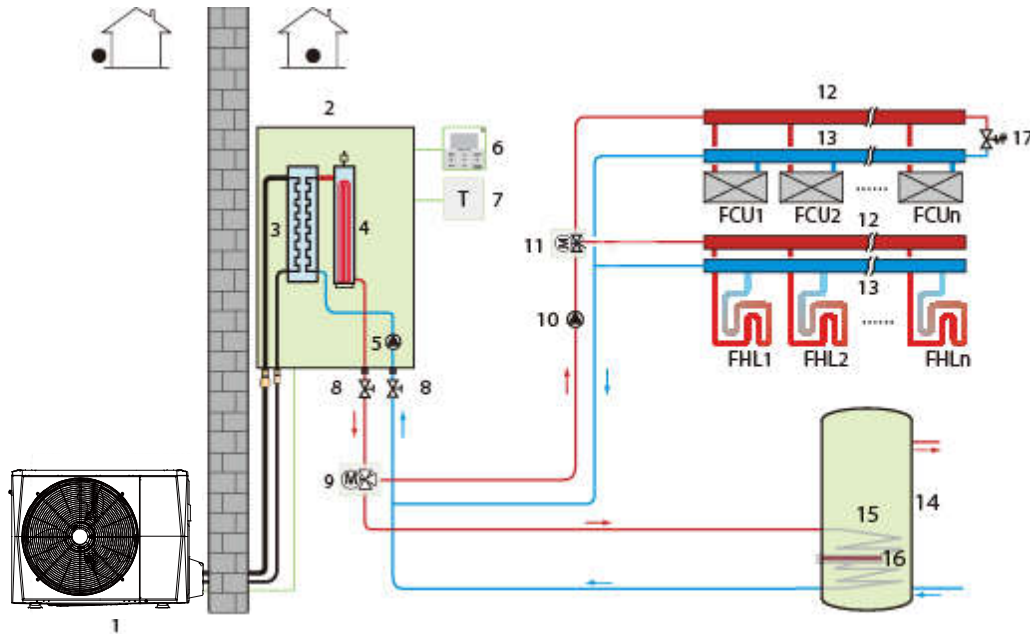

Legend			
1	Outdoor unit	11	3-way valve (field supplied)
2	Hydronic box	12	Distributor (field supplied)
3	Plate heat exchanger	13	Collector (field supplied)
4	Backup electric heater(optional)	14	Domestic hot water tank (field supplied)
5	Internal circulator pump	15	Heat exchanger coil
6	User interface	16	Immersion heater
7	Room thermostat (field supplied)	17	Bypass valve (field supplied)
8	Stop valve (field supplied)	FHL 1...n	Floor heating loops (field supplied)
9	Motorized 3-way valve (field supplied)	FCU 1...n	Fan coil units (field supplied)
10	External circulator pump (field supplied)		

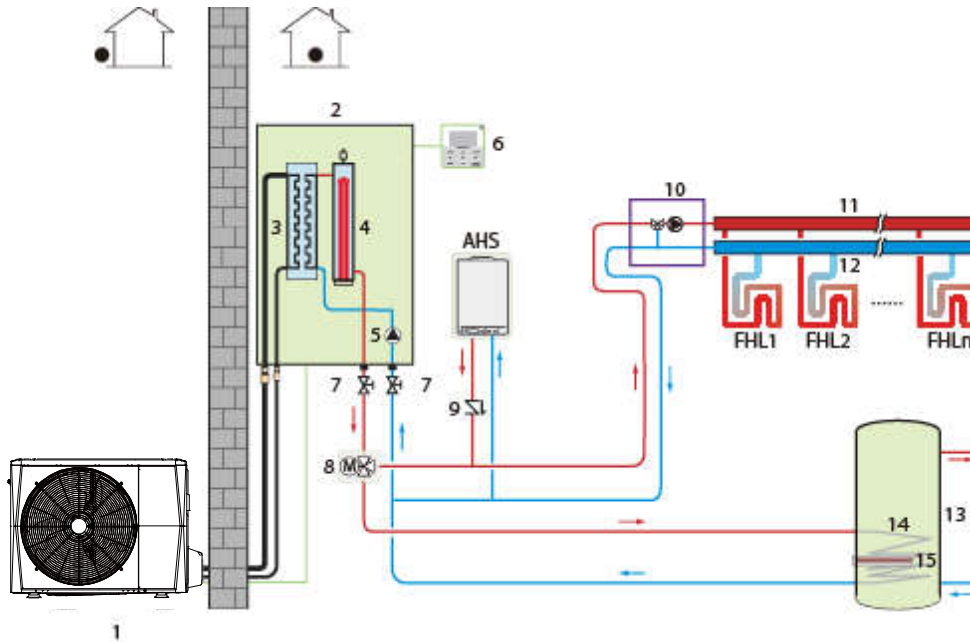
**4.4 Space Heating and Domestic Hot Water (Bivalent)**
**4.4.1 Auxiliary heat source provides space heating only**
*Figure 1-5.4: Space heating and domestic hot water with auxiliary heat source providing space heating only*

Legend			
1	Outdoor unit	10	Mixing station (field supplied)
2	Hydronic box	11	Distributor (field supplied)
3	Plate heat exchanger	12	Collector (field supplied)
4	Backup electric heater(optional)	13	Domestic hot water tank (field supplied)
5	Internal circulator pump	14	Heat exchanger coil
6	User interface	15	Immersion heater
7	Stop valve (field supplied)	FHL 1...n	Floor heating loops (field supplied)
8	Motorized 3-way valve (field supplied)	AHS	Auxiliary heating source (field supplied)
9	Non-return valve (field supplied)		

# S-Therm Yukon split series

## 4.4.2 Auxiliary heat source provides space heating and domestic hot water

Figure 1-5.5: Space heating and domestic hot water with auxiliary heat source providing space heating and domestic hot water

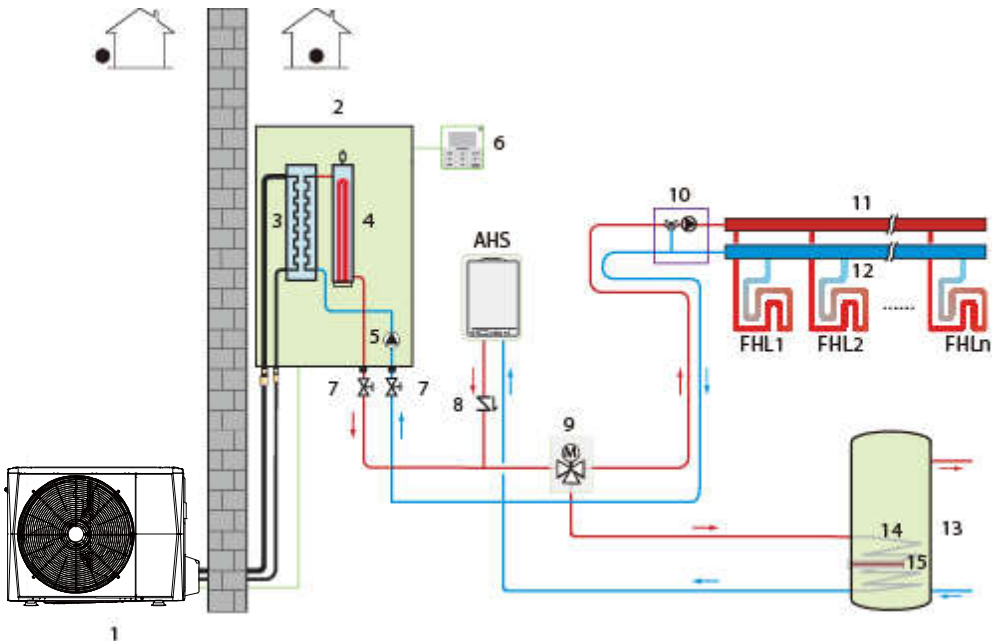

Legend			
1	Outdoor unit	10	Mixing station (field supplied)
2	Hydronic box	11	Distributor (field supplied)
3	Plate heat exchanger	12	Collector (field supplied)
4	Backup electric heater(optional)	13	Domestic hot water tank (field supplied)
5	Internal circulator pump	14	Heat exchanger coil
6	User interface	15	Immersion heater
7	Stop valve (field supplied)	FHL 1...n	Floor heating loops (field supplied)
8	Non-return valve (field supplied)	AHS	Auxiliary heating source (field supplied)
9	Motorized 3-way valve (field supplied)		

**4.4.3 Auxiliary heat source provides additional heating**

If the unit's outlet temperature is too low, the auxiliary heat source provides additional heating to raise the water temperature to the set temperature. An additional 3-way valve is required. When the unit's outlet temperature is too low, the 3-way valve is open and the water flows through the auxiliary heat source. When the unit's outlet temperature is high enough, the 3-way valve is closed.

Figure 1-5.6: Space heating and domestic hot water with auxiliary heat source providing additional heating

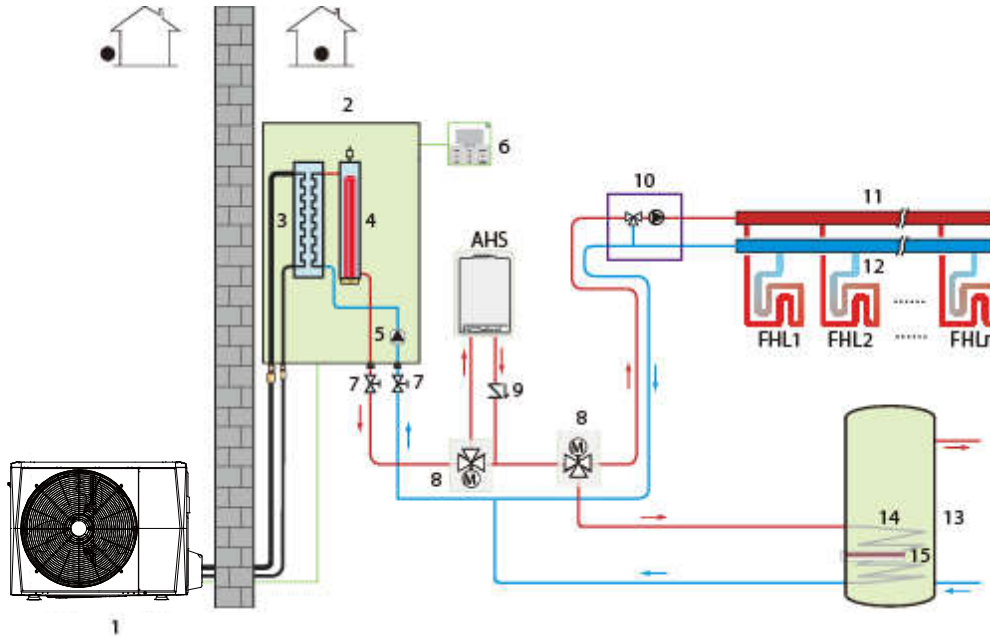

Legend			
1	Outdoor unit	10	Mixing station (field supplied)
2	Hydronic box	11	Distributor (field supplied)
3	Plate heat exchanger	12	Collector (field supplied)
4	Backup electric heater(optional)	13	Domestic hot water tank (field supplied)
5	Internal circulator pump	14	Heat exchanger coil
6	User interface	15	Immersion heater
7	Stop valve (field supplied)	FHL 1...n	Floor heating loops (field supplied)
8	Motorized 3-way valve (field supplied)	AHS	Auxiliary heating source (field supplied)
9	Non-return valve (field supplied)		

## S-Therm Yukon split series

### 4.5 Space Heating Through Floor Heating Loops and Radiators

The floor heating loops and radiators require different operating water temperatures. To achieve these two set points, a mixing station is required. Room thermostats for each zone are optional. With the help of hydronic adapter board (optional), maximum 8 thermostats for 8 rooms are available to control heat pump, which greatly improves the operation convenience.

Figure 1-5.7: Space heating through floor heating loops and radiators

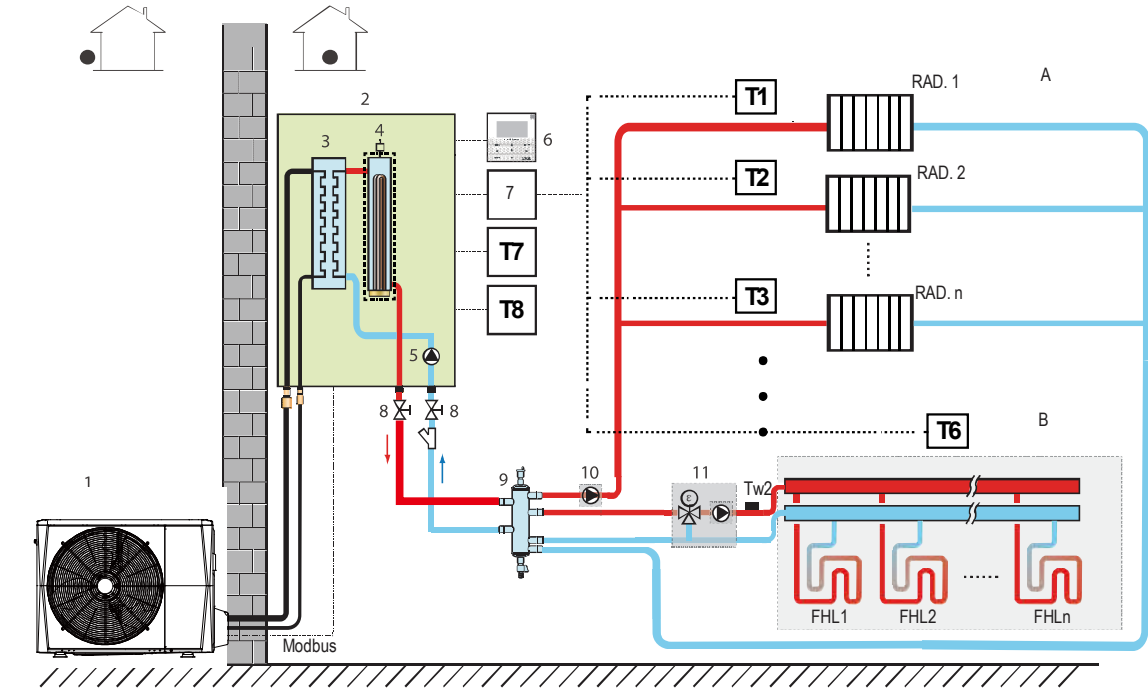

Legend			
1	Outdoor unit	10	External circulator pump (field supplied)
2	Hydronic box	11	Mixing station (field supplied)
3	Plate heat exchanger	12	Room thermostat (field supplied)
4	Backup electric heater(optional)	13	Bypass valve (field supplied)
5	Internal circulator pump	FHL 1...n	Floor heating loops (field supplied)
6	User interface(Integrated in hydronic box)	RAD 1...n	Radiators (field supplied)
7	Hydronic adapter board (Optional)	11	Mixing station (field supplied)
8	Stop valve (field supplied)	T1...8	Room thermostats (field supplied)
9	Balance tank (field supplied)		

**4.6 Space Heating, Space Cooling and Domestic Hot Water Compatible with Solar Water Heater**

Floor heating loops and fan coil units are used for space heating and fan coil units are used for space cooling. Domestic hot water is supplied from the domestic hot water tank connected to both the hydronic box and solar water heater. Solar water pump is controlled by Tsolar temperature sensor. Balance tank temperature sensor is used to control on/off of heat pump. Once the heat pump stops, internal pump stops to save energy and then balance tank provides hot water for space heating. In addition, balance tank temperature control can meet both space heating and domestic hot water needs at the same time.

Figure 1-5.8: Space heating, space cooling and domestic hot water compatible with solar water heater

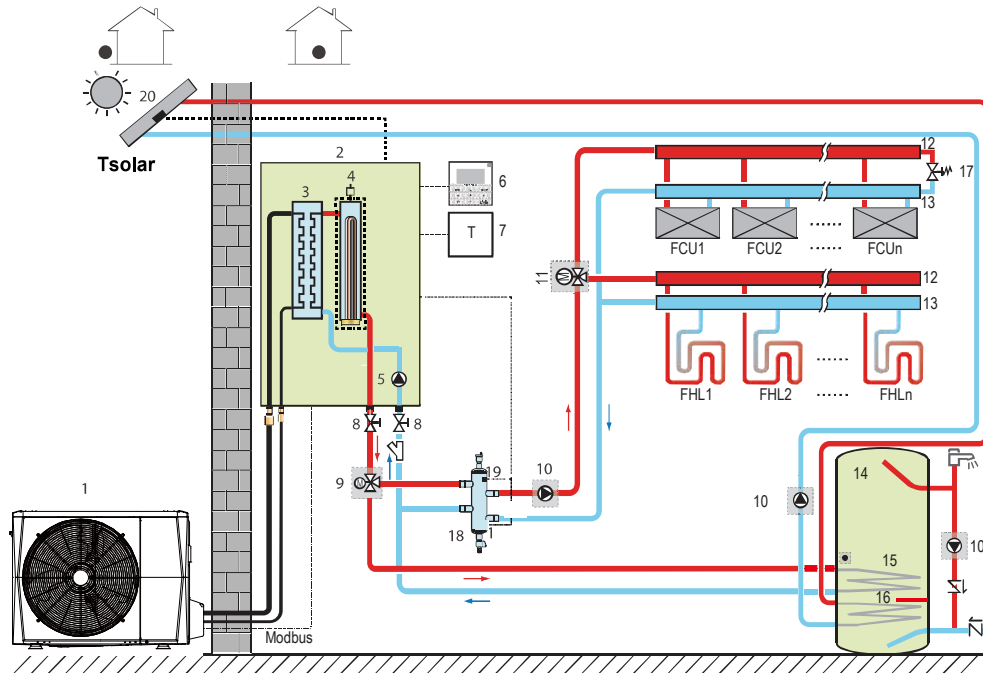

Legend			
1	Outdoor unit	12	Distributor (field supplied)
2	Hydronic box	13	Collector (field supplied)
3	Plate heat exchanger	14	Domestic hot water tank (field supplied)
4	Backup electric heater(optional)	15	Heat exchanger coil
5	Internal circulator pump	16	Immersion heater
6	User interface(Integrated in hydronic box)	17	Bypass valve (field supplied)
7	Room thermostat	18	Balance tank (field supplied)*
8	Stop valve (field supplied)	19	Balance tank temperature sensor (optional)
9	Motorized 3-way valve (field supplied)	FHL 1...n	Floor heating loops (field supplied)
10	External circulator pump (field supplied)	FCU 1...n	Fan coil units (field supplied)
11	Motorized 3-way valve (field supplied)		

Note:

- Balance tank volume requirement  
 For MSH-60IB; MSH-60IB/3, balance tank volume  $\geq 25L$   
 For MSH-100IB; MSH-100IB/3; MSH-100IB-3/9, balance tank volume  $\geq 25L$   
 For MSH-160IB; MSH-160IB/3; MSH-160IB-3/9, balance tank volume  $\geq 40L$

# Part 6

## Engineering Data

<b>1 Specifications .....</b>	<b>129</b>
<b>2 Dimensions and Center of Gravity .....</b>	<b>135</b>
<b>3 Piping Diagrams .....</b>	<b>138</b>
<b>4 Wiring Diagrams.....</b>	<b>140</b>
<b>5 CAPACITY TABLES .....</b>	<b>144</b>
<b>6 Operating Limits.....</b>	<b>160</b>
<b>7 Hydronic Performance.....</b>	<b>161</b>
<b>8 Sound Levels .....</b>	<b>163</b>
<b>9 Accessories .....</b>	<b>167</b>

## 1 Specifications

### 1.1 Outdoor Unit

Model name			MSH-40EB	MSH-60EB	MSH-80EB	MSH-100EB
Compatible hydronic box			MSH-60IB; MSH-60IB/3		MSH-100IB MSH-100IB/3 MSH-100IB-3/9	
Power supply		V/Ph/H	220-240/1/50			
Heating(A7W35)	Capacity	kW	4.25	6.20	8.30	10.0
	Rated input	kW	0.82	1.24	1.60	2.00
	COP			5.20	5.00	5.20
Heating(A7W45)	Capacity	kW	4.35	6.35	8.20	10.0
	Rated input	kW	1.14	1.69	2.08	2.63
	COP			3.80	3.75	3.95
Heating(A7W55)	Capacity	kW	4.40	6.00	7.50	9.50
	Rated input	kW	1.49	2.00	2.36	3.06
	COP			2.95	3.00	3.18
Heating(A-7W35)	Capacity	kW	4.8	6.1	7.1	8.25
	Rated input	kW	1.52	2	2.18	2.62
	COP			3.15	3.05	3.25
Heating(A-7W55)	Capacity	kW	4	5.15	6.15	6.85
	Rated input	kW	2.05	2.58	3	3.43
	COP			1.95	2	2.05
Cooling(A35W18)	Capacity	kW	4.50	6.55	8.40	10.00
	Rated input	kW	0.81	1.34	1.66	2.08
	EER			5.55	4.90	5.05
Cooling(A35W7)	Capacity	kW	4.70	7.00	7.40	8.20
	Rated input	kW	1.36	2.33	2.19	2.48
	EER			3.45	3.00	3.38
Seasonal space heating energy efficiency class <sup>7</sup>	LWT at 35°C		A+++	A+++	A+++	A+++
	LWT at 55°C		A++	A++	A++	A++
SCOP <sup>7</sup>	Warmer climate	35°C	6.46	6.57	6.99	7.09
		55°C	4.15	4.21	4.51	4.62
	Average climate	35°C	4.85	4.95	5.22	5.20
		55°C	3.31	3.52	3.37	3.47
	Colder climate	35°C	4.06	4.21	4.33	4.32
		55°C	2.63	2.85	2.88	2.99
SEER	LWT at 7°C		4.99	5.34	5.83	5.98
	LWT at 18°C		7.77	8.21	8.95	8.78
MOP(Maximum overcurrent protection)	A		18	18	19	19
MCA( Minimum circuit amps)	A		12	14	16	17
Rated water flow	m <sup>3</sup> /h		0.73	1.07	1.43	1.72
Compressor	Type		Twin rotary DC inverter		Twin rotary DC inverter	
Outdoor fan	Motor type		Brushless DC motor		Brushless DC motor	
	Number of fans		1	1	1	1
Air side heat exchanger	Type		Finned tube		Finned tube	
Refrigerant(R32)	Factory charge	kg	1.50	1.50	1.65	1.65
Throttle type			Electronic expansion valve		Electronic expansion valve	
Piping connections	Type		Flare	Flare	Flare	Flare
	Liquid Dia.(OD)	mm	Φ6.35	Φ6.35	Φ9.52	Φ9.52
	Gas Dia.(OD)	mm	Φ15.9	Φ15.9	Φ15.9	Φ15.9
	Min. pipe length	m	2	2	2	2

## S-Therm Yukon split series

	Max. pipe length	m	30	30	30	30
Installation height difference	Outdoor unit above	m	20	20	20	20
	Outdoor unit below	m	20	20	20	20
Sound power level <sup>8</sup>		dB	56	58	59	60
Sound pressure level <sup>9</sup>		dB	44	45	46	49
Net dimensions (W×H×D)		mm	1008×712×426	1008×712×426	1118×865×523	1118×865×523
Packed dimensions (W×H×D)		mm	1065×800×485	1065×800×485	1180×890×560	1180×890×560
Net/Gross weight		kg	58/63.5	58/63.5	75/89	75/89
Operating temperature range	Cooling	°C	-5 to 43			
	Heating	°C	-25 to 35			
	DHW	°C	-25 to 43			

Note:

1. Relevant EU standards and legislation: EN14511; EN14825; EN50564; EN12102; (EU) No 811:2013; (EU) No 813:2013; OJ 2014/C 207/02:2014.
2. Test standard: EN12102-1
3. Sound pressure level is the maximum value tested under the two conditions of Heating: A7W35 and Cooling: A35W18.

Model name			MSH-120EB	MSH-140EB	MSH-160EB
Compatible hydronic box			MSH-160IB; MSH-160IB/3; MSH-160IB-3/9		
Power supply		V/Ph/Hz	220-240/1/50		
Heating(A7W35)	Capacity	kW	12.1	14.5	16.0
	Rated input	kW	2.44	3.09	3.56
	COP			4.95	4.70
Heating(A7W45)	Capacity	kW	12.3	14.2	16.0
	Rated input	kW	3.24	3.89	4.44
	COP			3.80	3.65
Heating(A7W55)	Capacity	kW	12.0	13.8	16.0
	Rated input	kW	3.87	4.60	5.52
	COP			3.10	3.00
Heating(A-7W35)	Capacity	kW	10	12	13.3
	Rated input	kW	3.33	4.29	4.93
	COP			3	2.8
Heating(A-7W55)	Capacity	kW	10	11	12.5
	Rated input	kW	4.88	5.37	6.19
	COP			2.05	2.05
Cooling(A35W18)	Capacity	kW	12.00	13.50	14.2
	Rated input	kW	3.00	3.74	3.94
	EER			4.00	3.61
Cooling(A35W7)	Capacity	kW	11.6	12.7	14.0
	Rated input	kW	4.22	4.98	5.71
	EER			2.75	2.55
Seasonal space heating energy efficiency class <sup>7</sup>	LWT at 35°C		A+++	A+++	A+++
	LWT at 55°C		A++	A++	A++
SCOP <sup>7</sup>	Warmer climate	35°C	6.48	6.58	6.29
		55°C	4.43	4.49	4.48
	Average climate	35°C	4.81	4.72	4.62
		55°C	3.45	3.47	3.41
	Colder climate	35°C	4.08	4.07	4.02
		55°C	3.02	3.05	3.12
SEER	LWT at 7°C		4.89	4.86	4.69
	LWT at 18°C		7.1	6.9	6.75
MOP(Maximum overcurrent protection)		A	30	30	30
MCA( Minimum circuit amps)		A	25	26	27
Rated water flow		m <sup>3</sup> /h	2.08	2.49	2.75
Compressor	Type		Twin rotary DC inverter		
Outdoor fan	Motor type		Brushless DC motor		
	Number of fans		1	1	1
Air side heat exchanger	Type		Finned tube		
Refrigerant(R32)	Factory charge	kg	1.84	1.84	1.84
Throttle type			Electronic expansion valve		
Piping connections	Type		Flare	Flare	Flare
	Liquid Dia.(OD)	mm	Φ9.52	Φ9.52	Φ9.52
	Gas Dia.(OD)	mm	Φ15.9	Φ15.9	Φ15.9
	Min. / Max. pipe length		m	2/30	2/30
Installation height difference	Outdoor unit above		20	20	20
	Outdoor unit below		20	20	20
Sound power level <sup>8</sup>		dB	64	65	68
Sound pressure level <sup>9</sup>		dB	50	51	54

## S-Therm Yukon split series



Net dimensions (W×H×D)		mm	1118×865×523	1118×865×523	1118×865×523
Packed dimensions (W×H×D)		mm	1180×890×560	1180×890×560	1180×890×560
Net/Gross weight		kg	97/110.5	97/110.5	97/110.5
Operating temperature range	Cooling	°C	-5 to 43		
	Heating	°C	-25 to 35		
	DHW	°C	-25 to 43		

Note:

1. Relevant EU standards and legislation: EN14511; EN14825; EN50564; EN12102; (EU) No 811:2013; (EU) No 813:2013; OJ 2014/C 207/02:2014.
2. Test standard: EN12102-1
3. Sound pressure level is the maximum value tested under the two conditions of Heating: A7W35 and Cooling: A35W18.

Table 2-1.1: MSH-120EB-3; MSH-140EB-3; MSH-160EB-3 specifications<sup>1</sup>

Model name			MSH-120EB-3	MSH-140EB-3	MSH-160EB-3
Compatible hydronic box			MSH-160IB; MSH-160IB/3; MSH-160IB-3/9		
Power supply		V/Ph/H	380-415/3/50		
Heating(A7W35)	Capacity	kW	12.1	14.5	16.0
	Rated input	kW	2.44	3.09	3.56
	COP		4.95	4.70	4.50
Heating(A7W45)	Capacity	kW	12.3	14.2	16.0
	Rated input	kW	3.24	3.89	4.44
	COP		3.80	3.65	3.60
Heating(A7W55)	Capacity	kW	12.0	13.8	16.0
	Rated input	kW	3.87	4.60	5.52
	COP		3.10	3.00	2.90
Heating(A-7W35)	Capacity	kW	10	12	13.3
	Rated input	kW	3.33	4.29	4.93
	COP		3	2.8	2.7
Heating(A-7W55)	Capacity	kW	10	11	12.5
	Rated input	kW	4.88	5.37	6.19
	COP		2.05	2.05	2.02
Cooling(A35W18)	Capacity	kW	12.00	13.50	14.20
	Rated input	kW	3.00	3.74	3.94
	EER		4.00	3.61	3.61
Cooling(A35W7)	Capacity	kW	11.6	12.7	14.0
	Rated input	kW	4.22	4.98	5.71
	EER		2.75	2.55	2.45
Seasonal space heating energy efficiency class	LWT at 35°C		A+++	A+++	A+++
	LWT at 55°C		A++	A++	A++
SCOP	Warmer climate	35°C	6.47	6.57	6.28
		55°C	4.42	4.49	4.47
	Average climate	35°C	4.81	4.72	4.62
		55°C	3.45	3.47	3.41
	Colder climate	35°C	4.08	4.07	4.02
		55°C	3.02	3.05	3.12
SEER	LWT at 7°C		4.86	4.83	4.67
	LWT at 18°C		7.04	6.85	6.71
MOP(Maximum overcurrent protection)		A	14	14	14
MCA( Minimum circuit amps)		A	10	11	12
Rated water flow		m <sup>3</sup> /h	2.08	2.49	2.75
Compressor	Type		Twin rotary DC inverter		
Outdoor fan	Motor type		Brushless DC motor		
	Number of fans		1	1	1
Air side heat exchanger	Type		Finned tube		
Refrigerant(R32)	Factory charge	kg	1.84	1.84	1.84
Throttle type			Electronic expansion valve		
Piping connections	Type		Flare	Flare	Flare
	Liquid/ Gas Dia.(OD)	mm	Φ9.52/15.9	Φ9.52/15.9	Φ9.52/15.9
	Min. /Max. pipe length		m	2/30	2/30
Installation height	Outdoor unit above/below		m	20	20
Sound power level <sup>2</sup>		dB	64	65	68
Sound pressure level(1m) <sup>3</sup>		dB	50	51	55
Net dimensions (W×H×D)		mm	1118×865×523	1118×865×523	1118×865×523

## S-Therm Yukon split series



Packed dimensions (W×H×D)		mm	1180×890×560	1180×890×560	1180×890×560
Net/Gross weight		kg	112/125.5	112/125.5	112/125.5
Operating temperature range	Cooling	°C	-5 to 43		
	Heating	°C	-25 to 35		
	DHW	°C	-25 to 43		

Note:

1. Relevant EU standards and legislation: EN14511; EN14825; EN50564; EN12102; (EU) No 811:2013; (EU) No 813:2013; OJ 2014/C 207/02:2014.
2. Test standard: EN12102-1
3. Sound pressure level is the maximum value tested under the two conditions of Heating: A7W35 and Cooling: A35W18.

### 1.2 Hydronic Box

Model name			MSH-60IB MSH-60IB/3	MSH-100IB MSH-100IB/3 MSH-100IB-3/9	MSH-160IB MSH-160IB/3 MSH-160IB-3/9	
Compatible Outdoor unit model			MSH-40EB MSH-60EB	MSH-80EB MSH-100EB	MSH-120EB MSH-120EB-3 MSH-140EB MSH-140EB-3 MSH-160EB MSH-160EB-3	
Function			Heating and cooling			
Setting water temperature range	Cooling	°C	5~25			
	Heating	°C	25~65			
	DHW <sup>3</sup>	°C	30~60			
Power supply		V/Ph/Hz	220-240/1/50	220-240/1/50	220-240/1/50	
Sound power level <sup>1</sup>		dB	38	42	43	
Sound pressure level(1m) <sup>2</sup>		dB	28	30	32	
Dimension (W×H×D)		mm	420×790×270	420×790×270	420×790×270	
Packing (W×H×D)		mm	525×1050×360	525×1050×360	525×1050×360	
Net/gross weight		kg	37/43 (without e-heater) 43/49 (with e-heater)	37/43 (without e-heater) 43/49 (with e-heater)	39/45 (without e-heater) 45/51 (with e-heater)	
Water circuit	Piping connections		inch	R1"	R1"	R1"
	Safety valve set pressure		MPa	0.3	0.3	0.3
	Drainage pipe connection		mm	Φ25	Φ25	Φ25
	Expansion tank	Volume	L	8.0	8.0	8.0
		Max. water pressure	MPa	0.3	0.3	0.3
		Pre-pressure	MPa	0.1	0.1	0.1
	Water side	Type		Plate type	Plate type	Plate type
	Water pump head		m	9	9	9
	Water flow range		m <sup>3</sup> /h	0.4~1.25	0.4~2.10	0.70~3.00
Internal water volume		L	5.0	5.0	5.0	
Refrigerant circuit	Liquid Dia. (OD)		mm	Φ6.35	Φ9.52	Φ9.52
	Gas Dia. (OD)		mm	Φ15.9	Φ15.9	Φ15.9

Note: 1. Test standard: EN12102-1

2. Sound pressure level is the maximum value tested under the two conditions of Heating: A7W35 and Cooling: A35W18 for different combination between outdoor unit and hydronic box.

3. Maximum domestic hot water temperature 60°C is only available with TBH support.

## 2 Dimensions and Center of Gravity

### 2.1 Outdoor Unit

#### MSH-40EB; MSH-60EB

Figure 2-2.1: MSH-40EB; MSH-60EB dimensions and center of gravity (unit: mm)

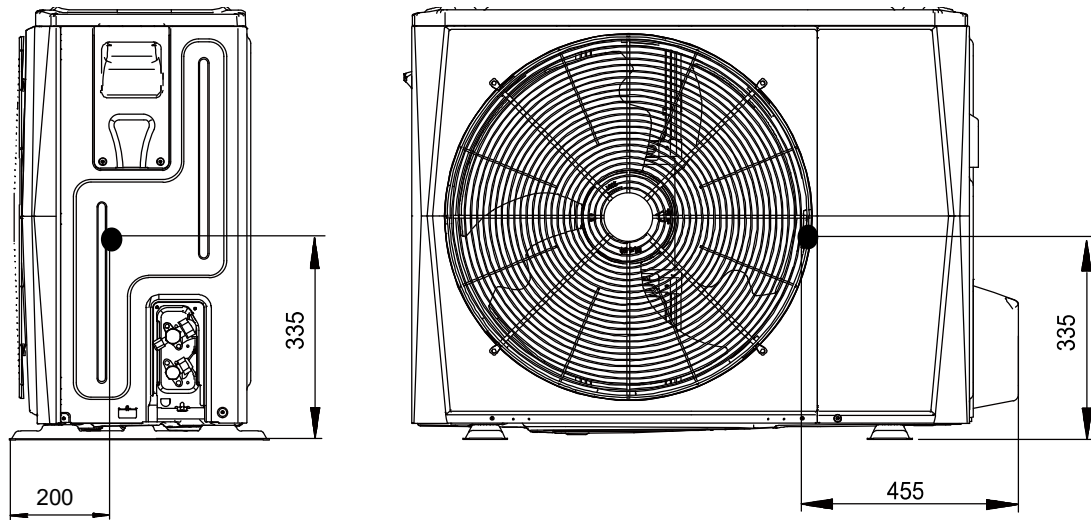

#### MSH-80EB; MSH-100EB

Figure 2-2.2: MSH-80EB; MSH-100EB dimensions and center of gravity (unit: mm)

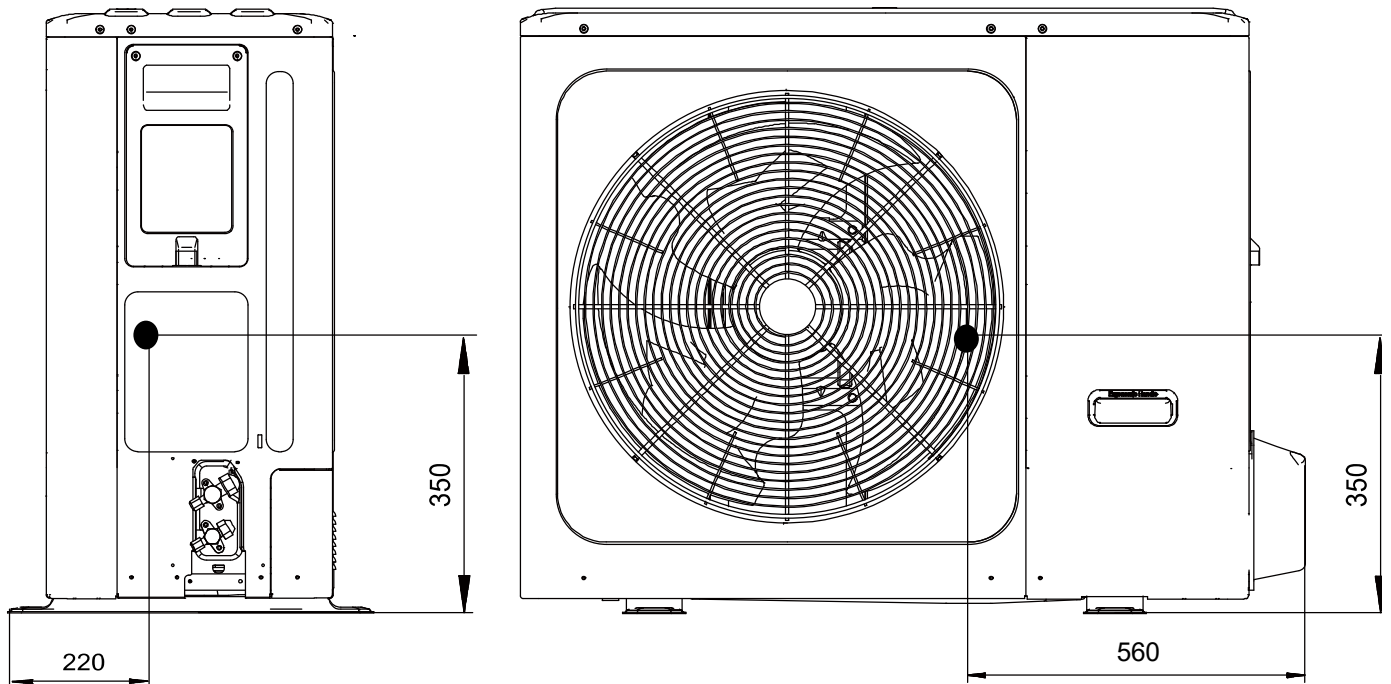

# S-Therm Yukon split series



## MSH-120EB; MSH-140EB; MSH-160EB

Figure 2-2.2: MSH-120EB; MSH-140EB; MSH-160EB dimensions and center of gravity (unit: mm)

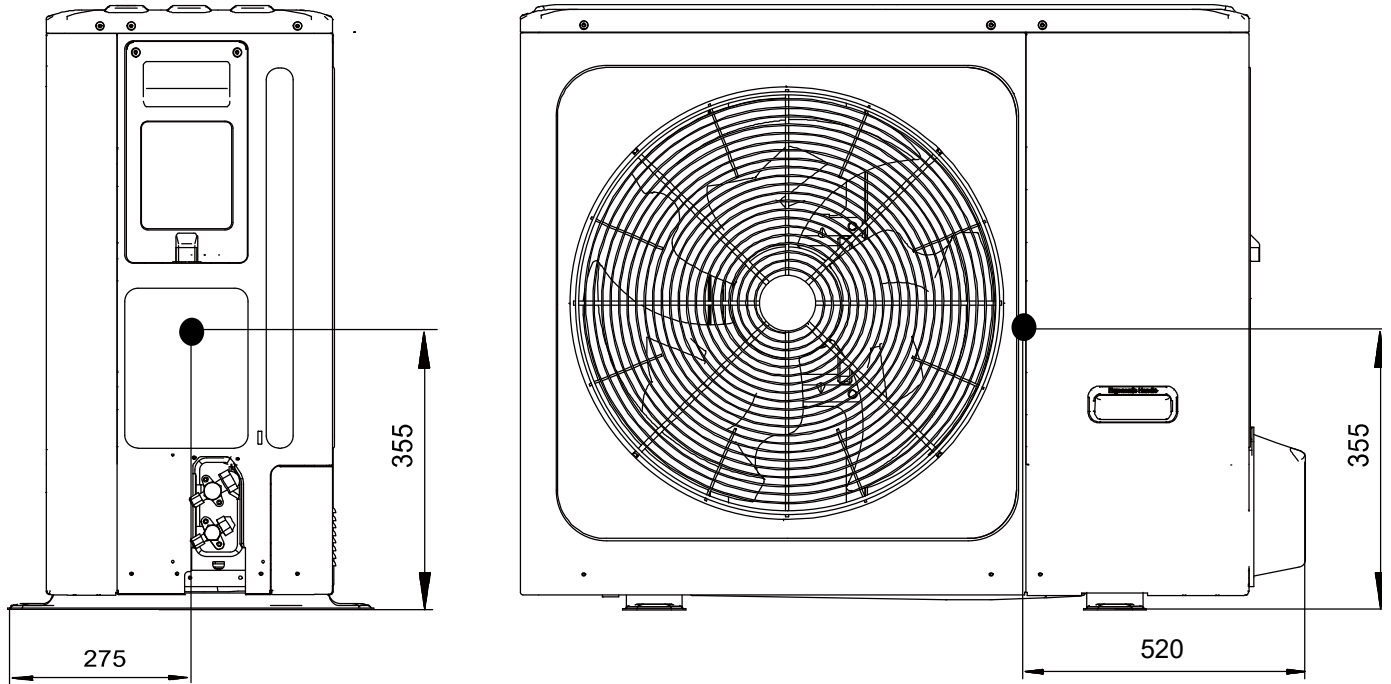

## MSH-120EB-3; MSH-140EB-3; MSH-160EB-3

Figure 2-2.2: MSH-120EB-3; MSH-140EB-3; MSH-160EB-3 dimensions and center of gravity (unit: mm)

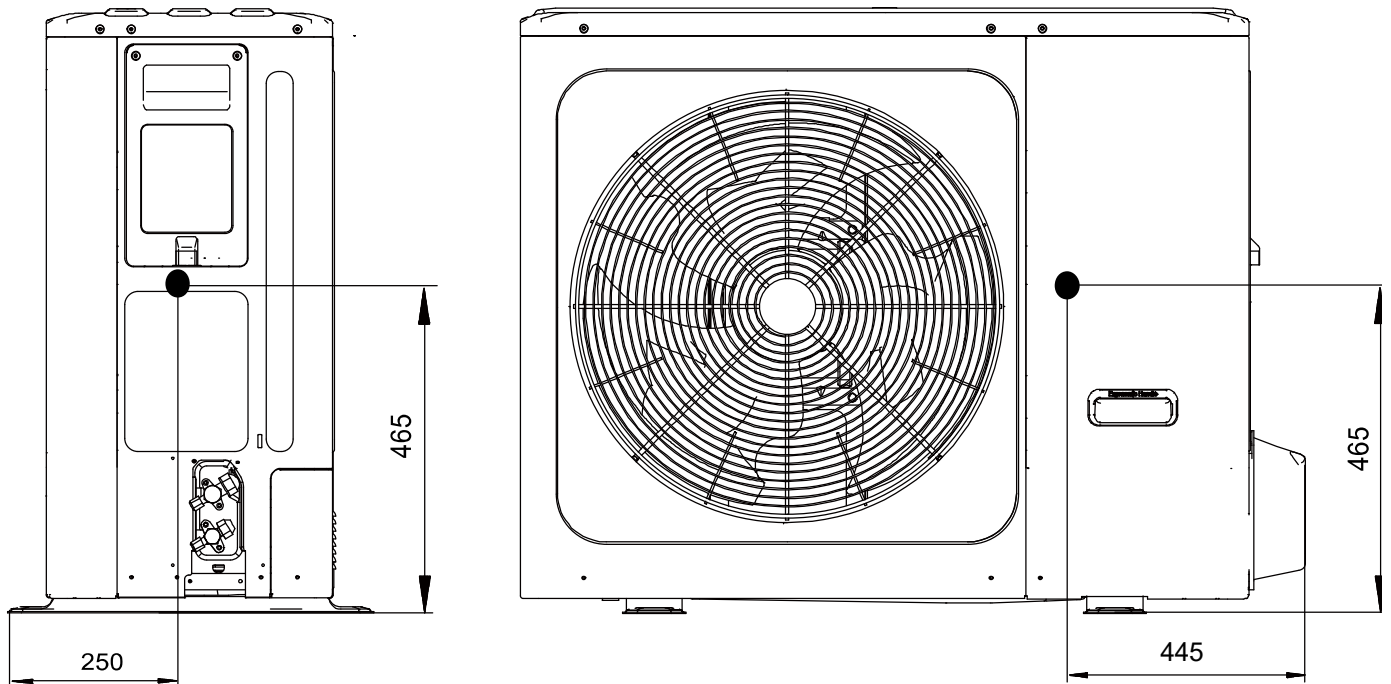

**2.2 Hydronic Box**

Figure 2-2.3: Hydronic box dimensions and center of gravity (unit: mm)

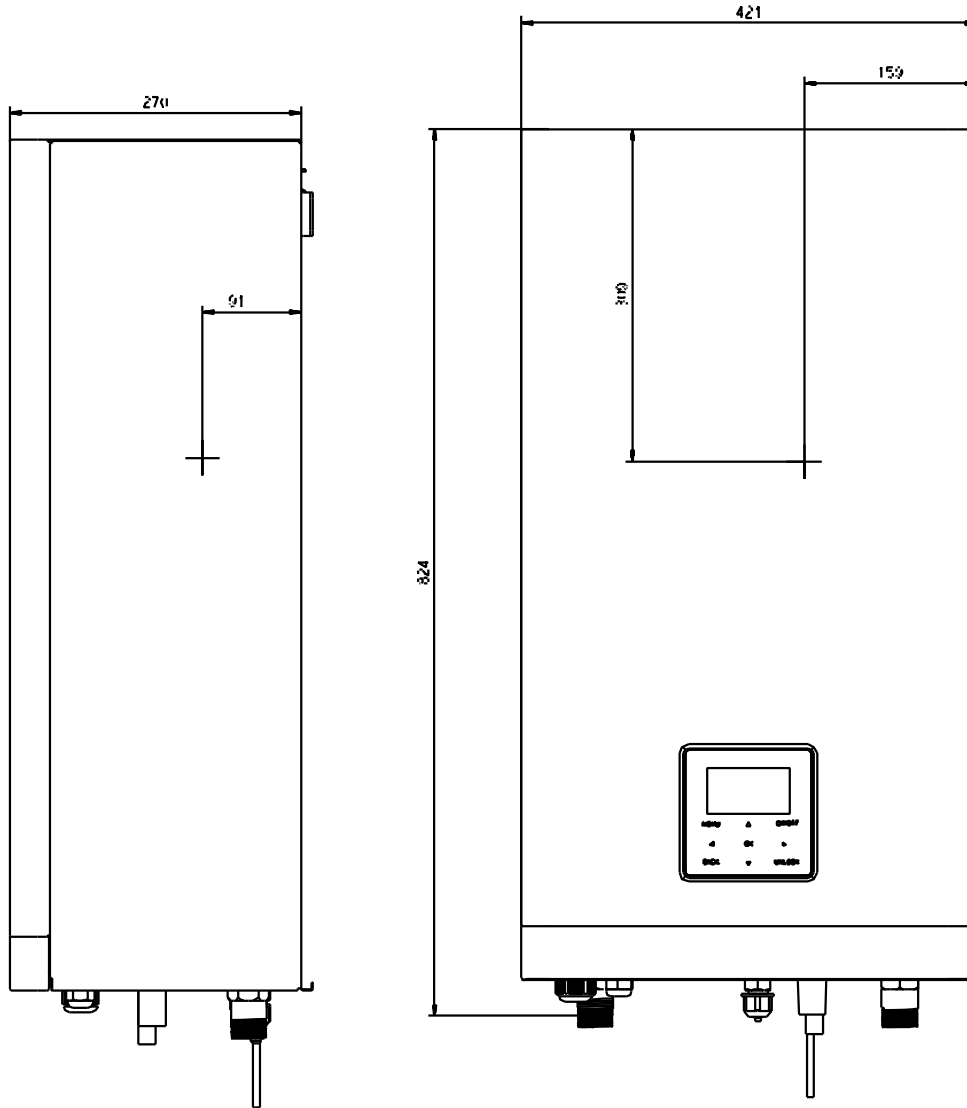

# S-Therm Yukon split series

## 3 Piping Diagrams

### 3.1 Outdoor Unit

Figure 2-3.1: Outdoor unit piping diagram

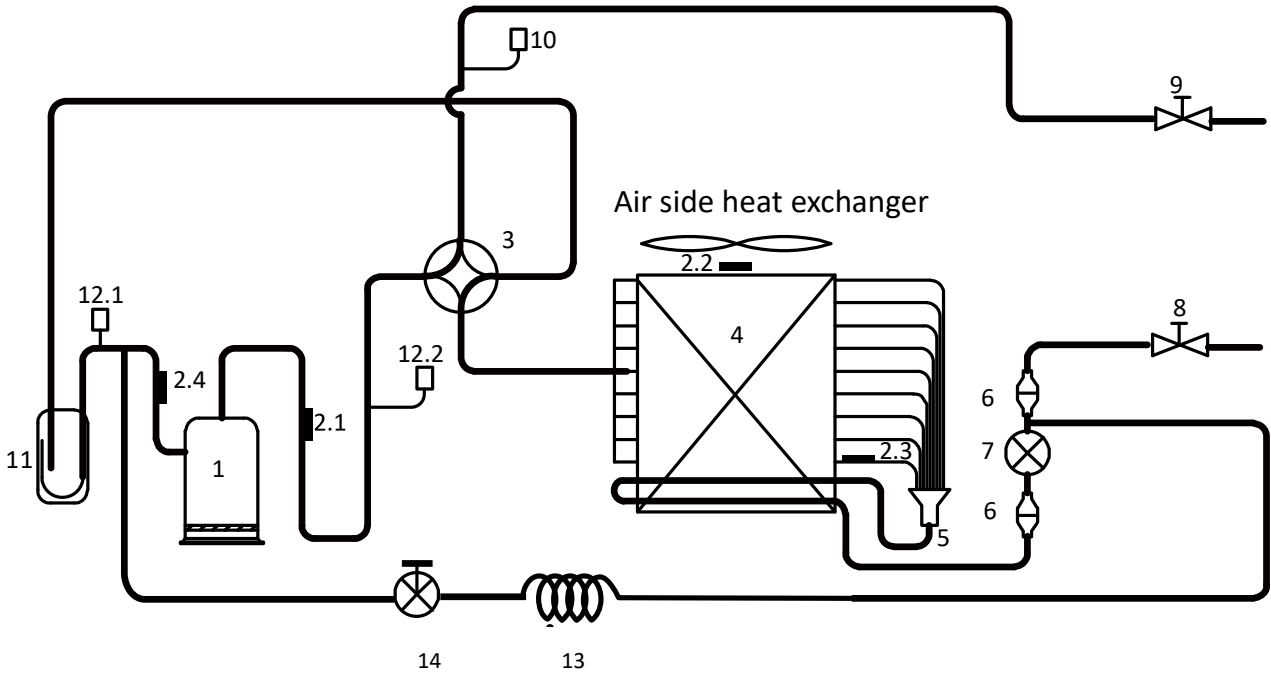

Legend			
1	Compressor	7	Electronic expansion valve
2.1	Discharge pipe temperature sensor	8	Stop valve (liquid side)
2.2	Outdoor ambient temperature sensor	9	Stop valve (gas side)
2.3	Air side heat exchanger refrigerant outlet temperature sensor	10	Pressure sensor
2.4	Suction pipe temperature sensor	11	Separator
3	4-way valve	12.1	Low pressure switch
4	Air side heat exchanger	12.2	High pressure switch
5	Distributor	13	Capillary
6	Filter	14	Solenoid valve

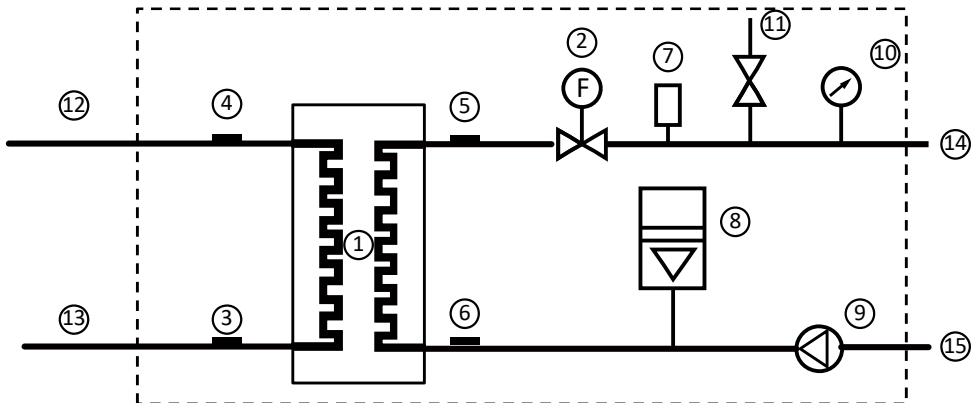
**3.2 Hydronic Box**
*Figure 2-3.2:Hydronic box piping diagram*

Legend			
1	Water side heat exchanger	9	Water pump
2	Water flow switch	10	Manometer
3	Refrigerant liquid line temperature sensor	11	Safety valve
4	Refrigerant gas line temperature sensor	12	Refrigerant gas side
5	Water outlet temperature sensor	13	Refrigerant liquid side
6	Water inlet temperature sensor	14	Water outlet
7	Air purge valve	15	Water inlet
8	Expansion vessel		

# S-Therm Yukon split series

## 4 Wiring Diagrams

### 4.1 Outdoor Unit

#### MSH-60EB; MSH-80EB; MSH-100EB

Figure 2-4.1: MSH-40EB; MSH-60EB; MSH-80EB; MSH-100EB wiring diagram

Temp. Sensor code	Property values
T3/T4/Th	$B_{25/50}=4100K, R_{25^{\circ}C}=10k\Omega$
Tp	$B_{25/50}=3950K, R_{90^{\circ}C}=5k\Omega$

CODE	Part name
4-WAY	4-WAY valve
COMP.	Compressor
CT1	AC current detector
EEV	Electric expensive valve
FAN	Outdoor fan motor
HEAT1-1	Comp. electrical heating tape1
HEAT1-2	Comp. electrical heating tape2
HEAT2	Chassis electrical heating tape
H-PRO	High pressure switch
L-PRO	Low pressure switch
MR1-MR5	Magnetic ring
P-SEN	Pressure sensor
T3	Condenser temp.sensor
T4	Outdoor ambient temp.sensor
TF	Radiator temp.sensor
Th	Suction temp.sensor
Tp	COMP. discharge temp.sensor
XT1-3	Terminal blocks

The wiring picture shown is for reference only, actual product may vary.

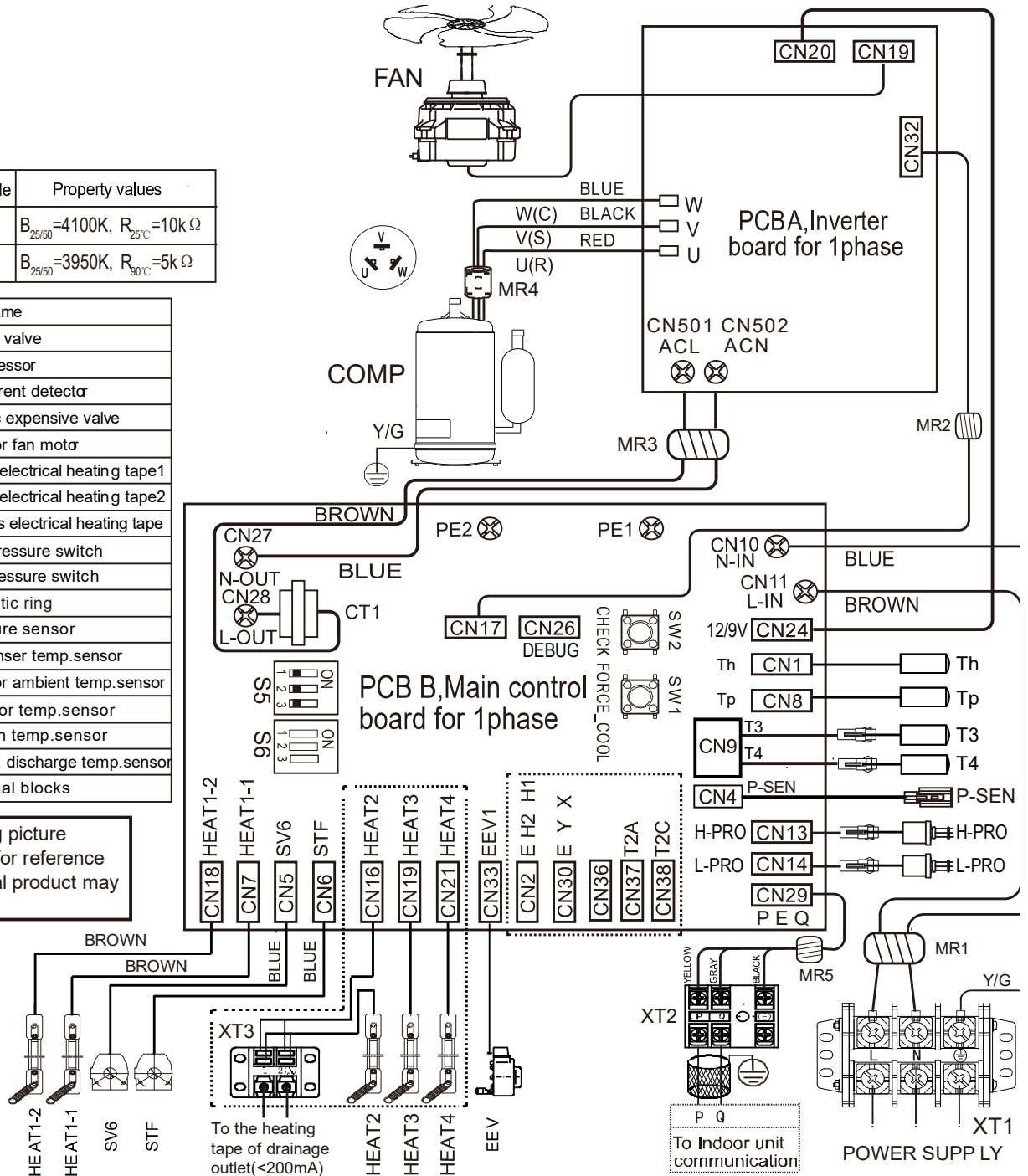

Factory code	Date	Revision
16025300005154	2020.05.15	F

NOTE: PLEASE USE 2-CORE SHIELDED WIRE

Leakage Protection Switch must be installed to the Power Supply of the unit.

## MSH-120EB; MSH-140EB; MSH-160EB

Figure 2-4.1: MSH-120EB; MSH-140EB; MSH-160EB wiring diagram

Temp. Sensor code	Property values
T3/T4/Th	$B_{25/50} = 4100K$ , $R_{25} = 10k\Omega$
Tp	$B_{25/90} = 3950K$ , $R_{90} = 5k\Omega$

CODE	Part name
4-WAY	4-WAY valve
COMP.	Compressor
CT1	AC current detector
EEV	Electric expansive valve
FAN	Outdoor fan motor
HEAT1-1	Comp. electrical heating tape1
HEAT1-2	Comp. electrical heating tape2
HEAT2	Chassis electrical heating tape
H-PRO	High pressure switch
L-PRO	Low pressure switch
MR1-MR5	Magnetic ring
P-SEN.	Pressure sensor
T3	Condenser temp.sensor
T4	Outdoor ambient temp.sensor
TF	Radiator temp.sensor
Th	Suction temp.sensor
Tp	COMP. discharge temp.sensor
XT1-3	Terminal blocks

The wiring picture shown is for reference only, actual product may vary.

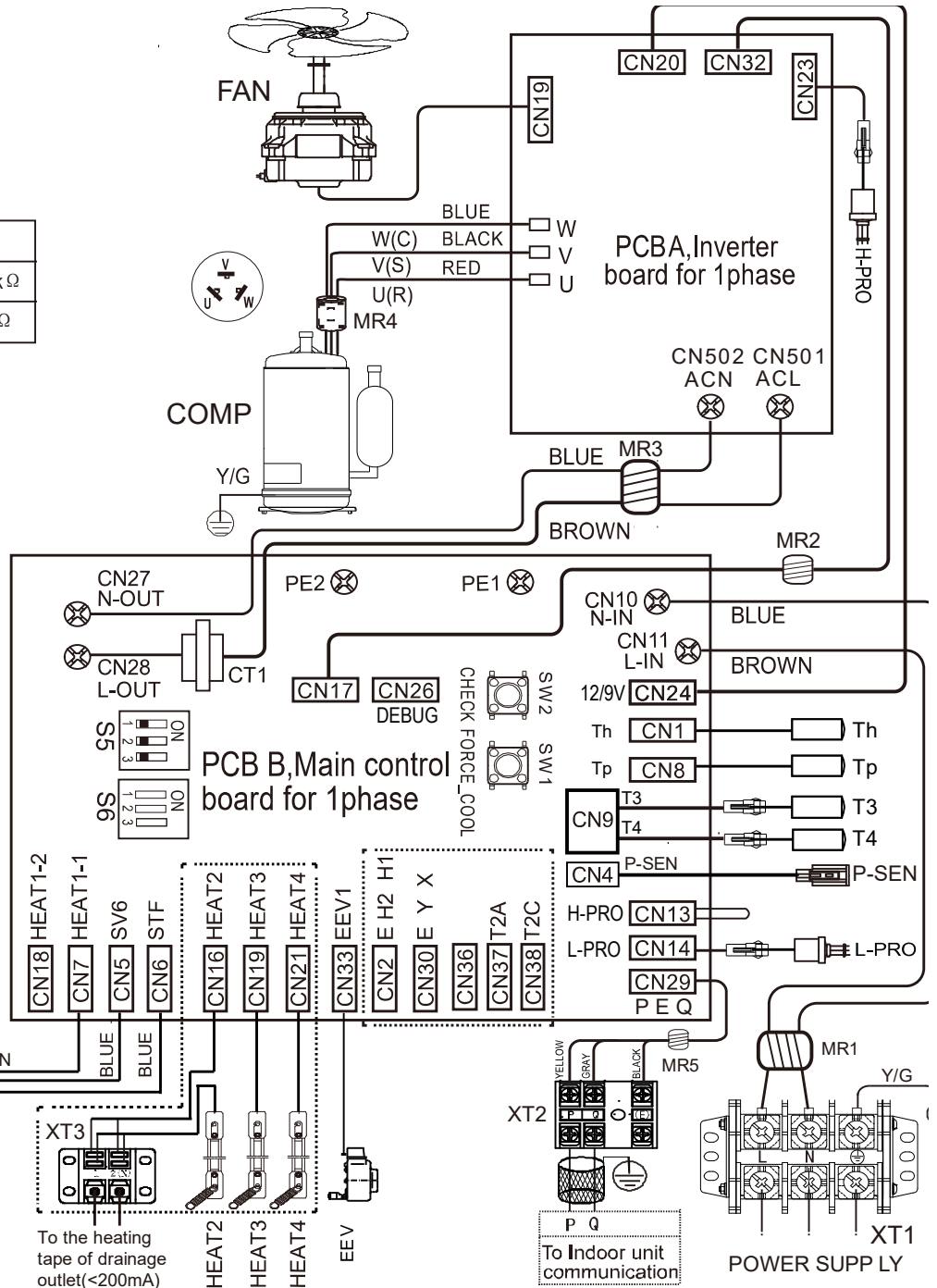

Factory code	Date	Revision
16025300005197	2020.05.15	F

NOTE: PLEASE USE 2-CORE SHIELDED WIRE

**!** Leakage Protection Switch must be installed to the Power Supply of the unit.

## MSH-120EB-3; MSH-140EB-3; MSH-160EB-3

Figure 2-4.1: MSH-120EB-3; MSH-140EB-3; MSH-160EB-3 wiring diagram

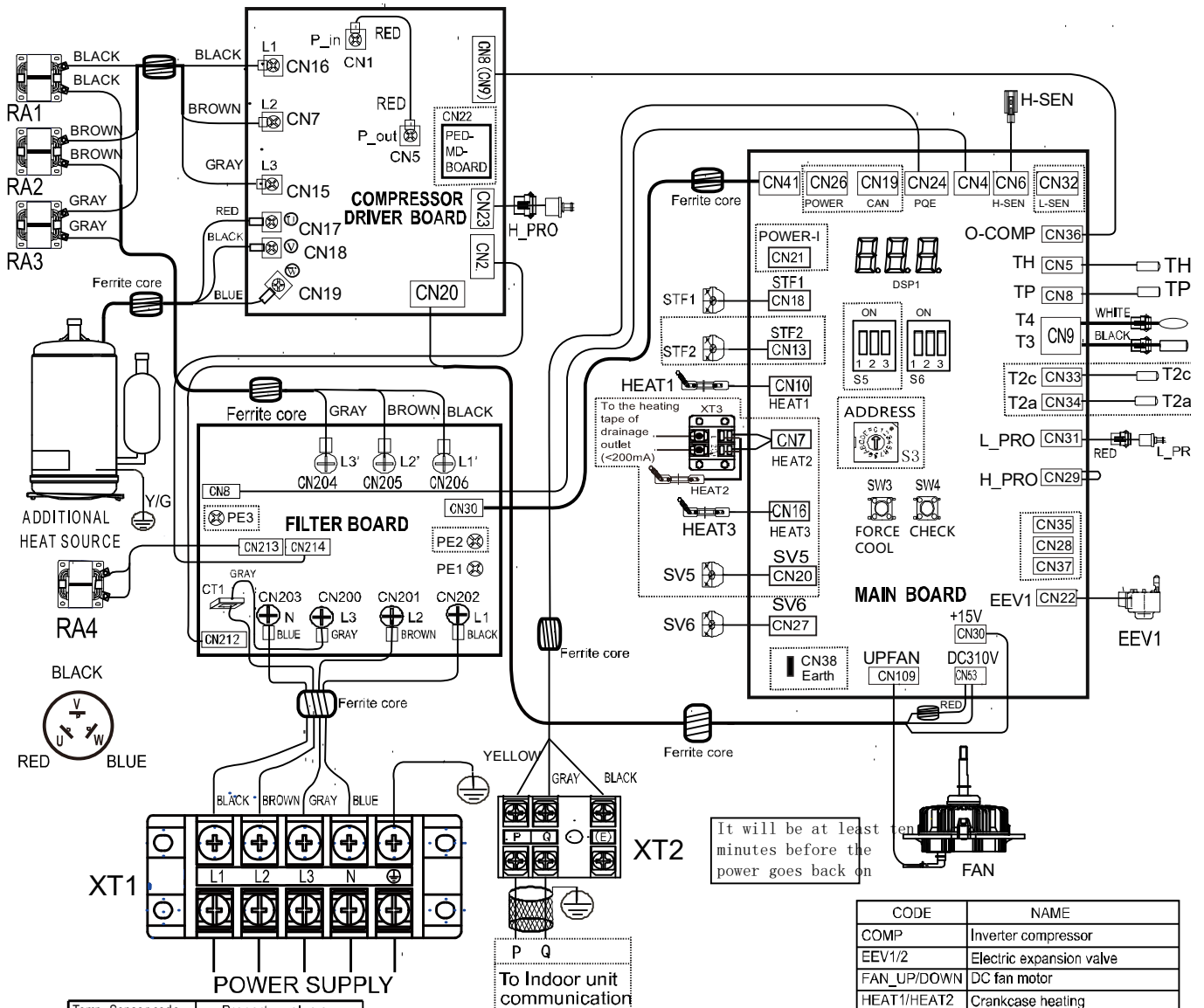

Temp. Sensor code	Property values
T3/T4/T6(Th)	$B_{25} = 4100K, R_{25} = 10k\Omega$
T5(Tp)	$B_{25} = 3950K, R_{25} = 5k\Omega$



**Leakage Protection Switch must be installed to the Power Supply of the electric heating.**

**Equipment must be grounded.**

The wiring picture shown is for reference only, actual product may vary.

Factory code	Date	Revision
16025300005134	2020.05.07	H

CODE	NAME
COMP	Inverter compressor
EEV1/2	Electric expansion valve
FAN_UP/DOWN	DC fan motor
HEAT1/HEAT2	Crankcase heating
H_PRO/L_PRO	High/Low pressure switch
H-SEN	High pressure sensor
XT1	Big 4-phase terminal
CT1	AC current transformer
RA	Reactor
STF1/STF2	4-way valve
SV5/SV6	Solenoid valve
T3/T3A	Piping temperature sensor
T4	Outdoor ambient temperature sensor
T5	Inverter compressor discharge temperature sensor
TP	Compressor exhaust temperature sensor
TH	Compressor return temperature sensor

## 4.2 Hydronic Box

MSH-60IB; MSH-60IB/3; MSH-100IB; MSH-100IB/3; MSH-100IB-3/9; MSH-160IB; MSH-160IB/3; MSH-160IB-3/9

Factory code	Date	Revision
16010600001226	2022.09.20	E

**Leakage Protection Switch must be installed to the Power Supply of the unit.**

**Main control board of indoor unit**

**DEFAULT**

**Caution**

- Operate the switches and push buttons with an insulated stick (such as a closed ball-point pen) to avoid touching of live parts.
- Querying external parameters and setting menu parameters are only allowed on the network converter assembly.

Temp. sensor code	Property values
T2/T2B	$B_{25.0C} = 4100K, R_{25.0C} = 10k\Omega$
T1/TW_out	$B_{10.0C} = 3970K, R_{10.0C} = 17.6k\Omega$
TW_in/T5/Tw2	

**THE FAULT OR PROTECTION TABLE**

Display	Fault or Protection
E0	Water flow fault(after 3 times E8)
E2	Communication fault between controller and indoor unit
E3	Final outlet water temp.sensor(T1) fault
E4	Water tank temp.sensor(T5) fault
E8	Water flow fault
Ez	Water temp.sensor (Tw_in) malfunction
EE	Indoor unit EEPROM fault
H0	Communication fault between indoor unit and outdoor unit
H2	Refrigerant liquid temp.sensor(T2) fault
H3	Refrigerant gas temp.sensor(T2B) fault
H5	Room temp.sensor(Ta) fault
H9	Outlet water for zone 2 temp.sensor (Tw2) fault
HA	Outlet water temp.sensor(Tw_out) fault
PS	Tw_out - Tw_in  value too big protection
Pb	Anti-freeze mode
PP	Tw_out - Tw_in unusual protection
Hb	Three times "PP" protection and Tw_out < 7°C
E7	Buffer tank up temp.sensor(Tb1) fault
Eb	Solar temp.sensor(Tsolar) fault
Ec	Buffer tank low temp.sensor(Tb2) fault
HE	Communication fault between indoor unit and temperature board

**THE CHECK TABLE**

Sequence	Content
0	Normal display(OFF display 0, ON display T1) (Show Tw_out when T1 invalid and including T1 is not set or T1 fault)
1	Unit address code Normal display(0-15)
2	Outdoor unit capability
3	Mode(0/Off, 2/Cool, 3/Heat, 5/Heat water)
4	Capacity requirements of current before
5	Capacity requirements of current after
6	T1: final outlet water temperature of indoor unit
7	Tb1: Balanced water tank of up temp. sensor
8	Ta: Ambient water tank of down temp. sensor
9	Tw2: outlet water temperature of Zone2
10	T1S: T1S value calculated from the curve
11	T1S2: setting outlet water temperature for Zone 2
12	Ta room temperature
13	T5: tank water temperature
14	T2: refrigerant liquid temperature
15	T2B: refrigerant gas temperature
16	Tw_out: outlet water temperature of plate heat exchanger
17	Tw_in: inlet water temperature of plate heat exchanger
18	Tsolar: solar panel temp. sensor
19	T4: ambient temperature of outdoor
20	Current(Reserved)
21	Current(Reserved)
22	Last failure
23	Last second failure
24	Last third failure
25	Software version

**NOTE**

- Equipment must be grounded.
- All high-voltage external load, if it is metal or a grounded port, must be grounded.
- External load current is needed less than 0.5A, if the load current is greater than 0.5A the load must be controlled through AC contactor. Each external load current is needed less than 0.5A.
- "AHS1" "AHS2", "R1" "R2" and "DF1" "DF2" wiring terminal ports provide only the switch signal.

**Figure1: 3-Phase 3/6/9KW IBH(Three step control)**

**Figure2: 1-Phase 3KW IBH(One step control)**

**Figure3: No IBH (Base)**

CODE	NAME
SW1/SW2	Key
S3	Rotary dip switch
S1/S2/S4/SW9	Switch
FS	Flow switch
SV1~SV3	MotORIZED 3-way valve (field supply)
T2, T2B, TW_in, TW_out, T1, Tb1, Tb2, T5, TW2, Tsolar	Temperature sensor
PUMP	Variable speed pump
XT1	Terminal block
SG	Solar energy
EJU	Commercial power
MUM2	Remote switch
KM+KM3	AC Contactor
KM5 - KM11	AC Contactor
IBH	Internal electric heater 1
ATCO	Auto reset thermal protector
TCD	Manual reset thermal protector

DIP switch	ON=1	OFF=0	Factory default
S1	0/0=IBH(One-Step control) 0/1=IBH(Two-Step control) 1/1=IBH(Three-Step control) 0/0=Without IBH and AHS 0/1=With AHS for heat mode 1/0=With IBH 1/1=With AHS for heat mode and DHW mode	See the figure	
S2	Start Pump 0 after 24 hours will be invalid With TBH Start Pump 0 after 24 hours will be valid	OFF	
S3	0/0=variable speed pump, Max. head 8.5m (GRUNDFOS) 1/1=variable speed pump, Max. head 5.0m (WLO, SHIMGE, SHINHO)	3 OFF 4 ON	
S4	1 Reserved 2 IBH for DHW is valid 3 Reserved 4 Reserved	1 OFF 2 OFF 3 OFF 4 OFF	

**CN11** (The current of load is <math>\leq 0.2A</math>, the AC contactor is required to be connected to the load)

**CN7** (The current of load is <math>\leq 0.2A</math>, the AC contactor is required to be connected to the load)

**CN30**

## 5 Capacity Tables

### 5.1 Heating Capacity Tables (Test standard: EN14511)

Table 2-5.1: Heating capacity for MSH-40EB

Maximum																											
DB	LWT																										
	25			30			35			40			45			50			55			60			65		
	HC	PI	COP	HC	PI	COP	HC	PI	COP	HC	PI	COP	HC	PI	COP	HC	PI	COP	HC	PI	COP	HC	PI	COP	HC	PI	COP
-25	2.05	1.18	1.74	1.80	1.22	1.48	1.71	1.32	1.29	1.53	1.30	1.18	1.37	1.25	1.10	/	/	/	/	/	/	/	/	/	/		
-20	3.09	1.31	2.36	2.83	1.56	1.82	2.44	1.70	1.43	2.17	1.74	1.24	1.98	1.75	1.13	1.85	1.75	1.06	1.56	1.59	0.98	/	/	/	/		
-15	3.60	1.19	3.03	3.41	1.22	2.78	3.25	1.36	2.39	2.93	1.49	1.97	2.50	1.60	1.56	2.20	1.68	1.31	1.84	1.56	1.18	1.73	1.68	1.03	/	/	
-10	4.17	1.22	3.40	4.49	1.38	3.25	4.34	1.52	2.85	4.02	1.65	2.43	3.59	1.77	2.02	3.28	1.81	1.81	2.63	1.68	1.56	2.81	1.80	1.56	/	/	
-7	4.92	1.33	3.69	5.14	1.46	3.52	4.99	1.60	3.11	4.67	1.73	2.70	4.54	1.98	2.29	4.41	2.12	2.08	4.28	2.34	1.83	3.56	1.94	1.84	/	/	
-5	4.99	1.24	4.03	5.18	1.39	3.72	5.02	1.53	3.27	4.74	1.68	2.82	4.63	1.89	2.45	4.56	2.02	2.26	4.41	2.26	1.95	3.83	2.00	1.92	/	/	
0	5.41	1.07	5.06	5.27	1.21	4.34	5.10	1.36	3.74	4.92	1.55	3.18	5.04	1.74	2.89	5.02	2.03	2.48	5.13	2.16	2.37	4.40	2.10	2.09	/	/	
5	5.99	1.03	5.83	5.75	1.18	4.85	5.68	1.31	4.33	5.59	1.48	3.77	5.60	1.71	3.27	5.50	1.98	2.78	5.54	2.07	2.68	4.90	2.09	2.35	4.04	2.16	1.87
7	6.58	0.99	6.67	6.22	1.15	5.40	6.26	1.26	4.96	6.26	1.42	4.41	5.96	1.63	3.67	5.69	1.76	3.23	5.74	1.90	3.03	5.41	2.08	2.61	4.27	2.09	2.04
10	6.37	0.95	6.68	6.03	1.17	5.16	6.07	1.26	4.82	6.31	1.36	4.63	6.05	1.57	3.86	5.80	1.80	3.23	5.70	1.80	3.16	5.27	1.96	2.69	4.49	2.02	2.22
15	6.03	0.90	6.71	5.72	1.20	4.78	5.75	1.25	4.59	6.40	1.27	5.04	6.20	1.47	4.21	5.47	1.50	3.65	5.63	1.65	3.41	5.04	1.76	2.87	4.87	1.90	2.56
20	5.86	0.81	7.24	5.74	1.00	5.75	5.67	1.11	5.13	6.16	1.12	5.48	6.12	1.31	3.27	5.61	1.40	3.99	5.52	1.50	3.68	4.77	1.56	3.06	/	/	/
25	5.70	0.72	7.91	5.77	0.80	7.21	5.60	0.96	5.85	5.91	0.98	6.06	6.05	1.15	5.25	5.75	1.31	4.39	5.42	1.35	4.02	4.50	1.36	3.30	/	/	/
30	5.78	0.69	8.41	5.84	0.78	7.48	5.78	0.89	6.51	5.89	0.92	6.39	6.02	1.07	5.62	5.67	1.22	4.63	5.51	1.28	4.31	4.61	1.32	3.51	/	/	/
35	5.85	0.65	8.96	5.90	0.76	7.77	5.97	0.82	7.27	5.86	0.87	6.77	5.99	0.99	6.05	5.59	1.14	4.90	5.61	1.22	4.62	/	/	/	/	/	/
40	6.30	0.58	10.8	6.38	0.67	9.51	6.36	0.74	8.57	6.33	0.80	7.88	6.38	0.93	6.86	6.00	1.15	5.20	/	/	/	/	/	/	/	/	/
43	6.57	0.54	12.2	6.67	0.62	10.8	6.59	0.69	9.50	6.62	0.77	8.63	6.61	0.89	7.39	6.25	1.16	5.38	/	/	/	/	/	/	/	/	/

Normal																											
DB	LWT																										
	25			30			35			40			45			50			55			60			65		
	HC	PI	COP	HC	PI	COP	HC	PI	COP	HC	PI	COP	HC	PI	COP	HC	PI	COP	HC	PI	COP	HC	PI	COP	HC	PI	COP
-25	1.90	1.07	1.78	1.65	1.08	1.52	1.56	1.19	1.31	1.42	1.20	1.19	1.28	1.18	1.09	/	/	/	/	/	/	/	/	/	/	/	/
-20	2.82	1.15	2.45	2.57	1.38	1.86	2.20	1.49	1.48	1.98	1.57	1.26	1.83	1.61	1.14	1.73	1.61	1.07	1.50	1.52	0.99	/	/	/	/	/	/
-15	3.26	1.03	3.17	3.07	1.06	2.88	2.90	1.17	2.48	2.66	1.31	2.02	2.22	1.40	1.59	1.96	1.46	1.34	1.69	1.41	1.20	1.61	1.56	1.03	/	/	/
-10	3.73	1.04	3.60	4.00	1.18	3.40	3.82	1.30	2.95	3.60	1.45	2.49	3.25	1.59	2.05	2.99	1.62	1.84	2.40	1.52	1.58	2.59	1.67	1.55	/	/	/
-7	4.59	1.19	3.85	4.63	1.27	3.65	4.80	1.52	3.15	4.26	1.52	2.81	4.30	1.83	2.35	4.12	1.93	2.14	4.00	2.05	1.95	3.15	1.68	1.87	/	/	/
-5	4.49	1.05	4.26	4.62	1.19	3.86	4.37	1.28	3.41	4.21	1.42	2.96	4.10	1.61	2.55	4.04	1.73	2.33	3.94	1.96	2.01	3.42	1.75	1.95	/	/	/
0	4.99	0.96	5.19	4.80	1.08	4.46	4.60	1.20	3.85	4.53	1.40	3.23	4.46	1.49	3.00	4.41	1.75	2.52	4.43	1.78	2.49	3.87	1.86	2.09	/	/	/
5	5.48	0.91	6.04	5.19	1.03	5.03	5.08	1.13	4.49	5.11	1.32	3.86	4.82	1.41	3.42	4.53	1.59	2.86	4.56	1.66	2.75	4.28	1.81	2.37	3.30	1.68	1.96
7	4.60	0.66	6.98	4.36	0.77	5.65	4.25	0.82	5.20	4.38	0.95	4.64	4.35	1.14	3.80	4.54	1.45	3.12	4.40	1.49	2.95	4.27	1.61	2.65	3.54	1.64	2.16
10	5.73	0.80	7.13	5.28	0.98	5.41	5.36	1.08	4.97	5.64	1.17	4.83	5.48	1.40	3.91	5.20	1.57	3.31	4.96	1.54	3.23	4.84	1.76	2.74	3.67	1.56	2.35
15	5.48	0.75	7.32	5.06	0.99	5.13	5.14	1.06	4.84	5.78	1.08	5.38	5.67	1.30	4.37	5.11	1.33	3.83	4.96	1.40	3.53	4.68	1.58	2.97	4.03	1.45	2.77
20	5.36	0.67	7.96	5.11	0.82	6.22	5.09	0.93	5.46	5.59	0.95	5.89	5.63	1.16	4.88	5.27	1.25	4.23	4.89	1.27	3.84	4.45	1.45	3.07	/	/	/
25	5.08	0.58	8.75	5.24	0.67	7.85	5.12	0.82	6.27	5.47	0.83	6.55	5.67	1.02	5.53	5.50	1.17	4.68	4.89	1.16	4.23	4.28	1.28	3.34	/	/	/
30	5.18	0.55	9.37	5.33	0.65	8.20	5.32	0.76	7.01	5.48	0.79	6.97	5.67	0.95	5.97	5.45	1.10	4.97	5.01	1.10	4.56	4.41	1.23	3.57	/	/	/
35	5.29	0.53	10.1	5.44	0.63	8.57	5.54	0.70	7.89	5.50	0.74	7.43	5.70	0.88	6.47	5.42	1.02	5.30	5.14	1.04	4.92	/	/	/	/	/	/
40	5.78	0.47	12.2	5.77	0.55	10.6	5.73	0.61	9.37	5.78	0.66	8.70	5.89	0.80	7.38	5.66	1.00	5.67	/	/	/	/	/	/	/	/	/
43	6.08	0.44	13.9	6.09	0.50	12.1	6.00	0.57	10.5	6.09	0.63	9.60	6.15	0.77	8.01	5.94	1.01	5.90	/	/	/	/	/	/	/	/	/

Minimum																											
DB	LWT																										
	25			30			35			40			45			50			55			60			65		
	HC	PI	COP	HC	PI	COP	HC	PI	COP	HC	PI	COP	HC	PI	COP	HC	PI	COP	HC	PI	COP	HC	PI	COP	HC	PI	COP
-25	1.23	0.68	1.80	1.12	0.72	1.55	1.18	0.89	1.33	1.09	0.90	1.20	0.86	0.79	1.10	/	/	/	/	/	/	/	/	/	/	/	/
-20	1.73	0.69	2.50	1.53	0.80	1.90	1.42	0.94	1.51	1.39	1.08	1.29	1.23	1.07	1.15	1.28	1.18	1.08	1.14	1.14	1.00	/	/	/	/	/	/
-15	1.68	0.52	3.25	1.65	0.56	2.95	1.55	0.61	2.54	1.64	0.79	2.07	1.60	1.00	1.61	1.52	1.12	1.36	1.25	1.00	1.25	1.23	1.17	1.05	/	/	/
-10	1.65	0.45	3.70	1.75	0.50	3.50	1.71	0.56	3.04	2.09	0.82	2.56	2.17	1.04	2.09	2.23	1.19	1.88	1.82	1.14	1.60	2.02	1.27	1.58	/	/	/
-7	1.16	0.29	4.01	1.18	0.31	3.76	1.25	0.37	3.34	2.06	0.70	2.93	2.08	0.86	2.42	2.05	0.94	2.18	1.88	0.98	1.91	2.22	1.16	1.91	/	/	/
-5	1.36	0.31	4.38	1.36	0.34	3.98	1.42	0.40	3.51	2.06	0.67	3.07	2.16	0.83	2.60	2.09	0.92	2.27	1.99	0.98	2.04	2.29	1.15	1.99	/	/	/
0	1.45	0.27	5.37	1.51	0.33	4.61	1.42	0.36	3.98	2.12	0.63	3.34	2.22	0.72	3.07	2.24	0.90	2.48	2.21	1.00	2.21	2.61	1.22	2.14	/	/	/
5	1.97	0.31	6.28	1.99	0.38	5.23	1.92	0.41	4.66	2.58	0.64	4.01	2.59	0.74	3.52	2.58	0.91	2.84	2.79	1.05	2.66	3.05	1.25	2.44	2.33	1.14	2.04
7	2.35	0.32	7.28	2.34	0.40	5.89	2.31	0.43	5.39	2.95	0.62	4.78	3.22	0.82	3.91	3.22	1.00	3.23	3.65	1.16	3.15	3.56	1.30	2.75	2.71	1.19	2.24
10	1.95	0.26	7.46	1.77	0.31	5.67	1.92	0.37	5.21	2.84	0.56	5.06	3.27	0.81	4.06	3.19	0.93	3.44	3.60	1.07	3.35	3.53	1.24	2.85	2.87	1.17	2.44
15	2.36	0.31	7.72	2.25	0.41	5.42	2.25	0.44	5.12	2.96	0.52	5.68	3.43	0.75	4.58	3.37	0.84	4.01	4.05	1.10	3.70	3.68	1.23	3.00	3.07	1.06	2.90

20	2.64	0.31	8.41	2.8 1	0.43	6.58	3.01	0.52	5.78	3.88	0.62	6.23	3.80	0.74	5.12	3.65	0.82	4.44	3.70	0.92	4.04	3.19	0.99	3.23	/	/	/
25	3.14	0.34	9.25	3.4 0	0.41	8.30	3.52	0.53	6.63	4.31	0.62	6.94	4.35	0.75	5.81	4.31	0.88	4.92	3.89	0.87	4.44	3.28	0.93	3.52	/	/	/
30	3.32	0.34	9.90	3.5 9	0.41	8.68	3.79	0.51	7.43	4.03	0.55	7.37	4.42	0.71	6.27	4.39	0.84	5.22	4.10	0.85	4.79	3.48	0.93	3.76	/	/	/
35	3.92	0.37	10.6	4.0 1	0.44	9.08	3.91	0.47	8.36	4.04	0.51	7.87	4.44	0.65	6.80	4.47	0.80	5.57	4.38	0.85	5.18	/	/	/	/	/	/
40	4.28	0.33	12.9	4.2 7	0.38	11.2	4.51	0.45	9.93	4.56	0.49	9.22	4.85	0.62	7.76	4.86	0.82	5.96	/	/	/	/	/	/	/	/	/
43	4.53	0.31	14.7	4.5 3	0.35	12.8	4.75	0.43	11.1	4.83	0.48	10.2	5.15	0.61	8.42	5.19	0.84	6.20	/	/	/	/	/	/	/	/	/

**Abbreviations:**

LWT: Leaving water temperature (°C)

DB: Dry-bulb temperature for Outdoor air temperature (°C)

HC: Total heating capacity (kW)

PI: Power input (kW)

**Table 2-5.2: Heating capacity for MSH-60EB**

Maximum																											
DB	LWT																										
	25			30			35			40			45			50			55			60			65		
	HC	PI	COP	HC	PI	COP	HC	PI	COP	HC	PI	COP	HC	PI	COP	HC	PI	COP	HC	PI	COP	HC	PI	COP	HC	PI	COP
-25	2.5 7	1.4 9	1.7 2	2.2 5	1.5 3	1.4 6	2.1 4	1.6 7	1.2 8	1.9 1	1.6 4	1.1 7	1.7 1	1.5 9	/	/	/	/	/	/	/	/	/	/	/	/	/
-20	3.6 4	1.5 6	2.3 4	3.3 6	1.8 6	1.8 3	2.8 8	2.0 3	1.4 2	2.5 6	2.0 8	1.2 3	2.3 8	2.0 2	1.1 9	2.1 9	2.0 7	1.8 4	1.8 6	0.9 9	/	/	/	/	/	/	/
-15	4.4 3	1.4 9	2.9 7	4.1 3	1.5 3	2.7 3	4.0 0	1.7 1	2.3 4	3.6 1	1.8 7	1.9 3	3.0 8	2.0 1	1.5 3	2.7 0	2.0 4	1.3 6	2.2 8	1.8 0	1.2 3	2.1 5	2.0 3	1.0 5	/	/	/
-10	5.7 5	1.6 9	3.4 1	5.5 0	1.8 4	2.9 9	5.1 1	1.9 9	2.5 7	4.8 3	2.1 8	2.2 8	4.6 4	2.2 7	4.1 3	2.4 1	2.4 2	1.7 0	3.8 4	2.2 0	1.6 9	3.3 2	2.3 4	1.4 4	/	/	/
-7	6.5 5	1.7 7	3.7 1	6.3 2	1.9 2	3.2 8	6.2 1	2.1 7	2.8 6	5.7 9	2.3 2	2.5 5	5.5 7	2.3 8	2.3 5	5.2 9	2.6 3	2.0 1	5.2 6	2.6 7	1.9 1	4.5 5	2.6 7	1.7 5	/	/	/
-5	6.5 4	1.6 4	3.9 8	6.3 2	1.7 9	3.5 4	6.1 4	1.9 9	3.0 0	5.9 7	2.1 8	2.7 4	5.8 4	2.3 0	2.5 4	5.4 4	2.4 3	2.2 1	5.3 4	2.6 1	2.0 3	4.7 1	2.5 3	1.8 3	/	/	/
0	6.4 9	1.3 4	4.8 7	6.3 8	1.4 8	4.3 1	6.3 5	1.6 8	3.7 0	6.8 9	1.9 2	3.4 5	6.8 5	2.2 5	3.0 8	5.8 8	2.3 7	2.4 8	5.4 2	2.5 9	2.0 9	5.0 6	2.5 4	1.9 9	/	/	/
5	7.0 4	1.3 1	5.3 7	6.7 0	1.5 0	4.4 8	6.8 8	1.6 4	4.2 5	6.9 6	1.8 9	3.6 9	6.9 9	2.1 2	3.2 9	6.3 7	2.2 1	2.8 1	6.1 6	2.4 8	2.4 4	5.7 3	2.5 7	2.2 2	4.9 2	2.68	1.84
7	7.5 8	1.2 8	5.9 0	7.0 6	1.4 7	4.8 1	7.4 6	1.5 4	4.7 3	7.1 9	1.7 3	3.9 9	7.1 3	2.0 8	3.5 7	6.8 7	2.1 3	3.1 0	6.9 2	2.3 7	2.9 1	6.4 2	2.5 5	2.5 5	5.2 5	2.60	2.02
10	7.4 3	1.2 1	6.1 5	7.1 2	1.3 6	5.2 4	7.3 5	1.4 6	5.0 2	7.3 7	1.7 5	4.2 7	7.3 2	1.9 3	3.7 8	7.0 1	2.0 5	3.3 3	6.9 8	2.2 4	3.0 2	6.2 7	2.4 0	2.6 7	5.5 0	2.52	2.21
15	7.1 7	1.1 3	6.3 5	7.2 0	1.2 4	5.8 2	7.2 6	1.3 8	5.2 8	7.7 8	1.6 9	4.6 8	7.6 3	1.8 6	4.1 4	7.2 1	1.9 7	3.6 7	6.9 8	2.1 2	3.3 0	6.0 1	2.2 3	2.7 0	6.1 0	2.39	2.56
20	6.9 3	0.9 7	7.1 5	6.9 1	1.1 8	6.2 8	6.9 8	1.1 8	5.9 1	7.2 1	1.5 4	4.7 0	7.4 2	1.6 8	4.4 2	7.2 8	1.8 1	4.0 2	6.8 9	1.8 0	3.6 8	5.9 8	1.9 5	3.0 6	/	/	/
25	6.6 9	0.8 0	8.3 2	6.7 4	0.9 5	7.1 6	6.7 3	1.0 6	6.3 1	6.6 5	1.3 0	5.1 1	7.2 1	1.5 2	4.7 4	7.3 3	1.6 6	4.4 3	6.6 6	1.6 0	5.9 4	1.6 4	3.5 5	/	/	/	
30	6.7 4	0.7 1	9.5 3	6.8 5	0.8 2	8.0 4	6.8 3	0.9 5	7.2 7	6.5 6	1.0 9	6.0 1	7.0 5	1.4 1	5.0 5	6.9 1	1.4 0	4.9 2	6.6 7	1.5 1	4.2 1	6.0 7	1.5 3	3.8 3	/	/	/
35	6.7 9	0.6 6	10.3 3	6.9 3	0.7 3	9.4 3	6.9 6	0.8 5	8.1 7	6.4 7	0.9 4	6.8 7	6.8 9	1.2 2	5.4 9	6.4 2	1.0 9	5.2 1	6.5 7	1.4 8	4.4 5	/	/	/	/	/	/
40	7.2 6	0.6 4	11.7 4	7.3 7	0.7 3	10.4 2	7.2 8	0.8 1	9.0 2	7.1 2	0.9 2	7.3 7	7.3 4	1.2 0	6.1 2	6.9 3	1.2 2	5.6 8	/	/	/	/	/	/	/	/	/
43	7.5 4	0.6 3	12.0 0	7.6 4	0.7 0	10.7 9	7.4 8	0.7 6	9.8 7	7.5 1	0.9 1	8.2 7	7.6 1	1.0 7	7.0 2	7.1 9	1.2 1	5.9 6	/	/	/	/	/	/	/	/	/
Normal																											
DB	LWT																										
	25			30			35			40			45			50			55			60			65		
	HC	PI	COP	HC	PI	COP	HC	PI	COP	HC	PI	COP	HC	PI	COP	HC	PI	COP	HC	PI	COP	HC	PI	COP	HC	PI	COP
-25	2.37	1.35	1.7 6	2.0 7	1.3 7	1.5 1	1.9 5	1.50 7	1.3 0	1.7 7	1.51 1	1.1 7	1.61 9	1.4 8	/	/	/	/	/	/	/	/	/	/	/	/	/
-20	3.33	1.37	2.4 3	3.0 4	1.6 5	1.8 5	2.6 5	1.78 5	1.4 6	2.3 6	1.87 3	1.2 5	2.16 5	1.9 2	1.1 6	2.0 4	1.8 8	1.7 8	1.7 8	1.0 0	/	/	/	/	/	/	/
-15	4.01	1.29	3.1 1	3.7 3	1.3 3	2.8 3	3.5 7	1.47 3	2.4 3	3.2 7	1.65 8	1.9 8	2.73 6	1.7 6	1.5 6	2.4 1	1.7 6	1.3 7	2.0 8	1.7 0	1.2 2	1.9 8	1.8 8	1.0 5	/	/	/
-10	5.15	1.43	3.6 1	4.8 9	1.5 7	3.1 2	4.5 2	1.69 4	2.6 6	4.3 3	1.91 7	2.2 7	4.21 7	2.0 1	2.1 0	3.7 6	2.1 5	1.7 6	3.4 3	2.0 3	1.7 6	3.0 6	2.1 3	1.4 4	/	/	/
-7	6.24	1.62	3.8 6	6.0 5	1.8 0	3.3 6	6.1 0	2.00 5	3.0 5	5.6 1	2.21 4	2.5 4	5.40 3	2.2 5	2.4 0	5.0 7	2.4 5	2.0 7	5.1 5	2.5 8	2.0 8	4.2 9	2.3 9	1.7 9	/	/	/
-5	5.89	1.40	4.2 0	5.6 4	1.5 4	3.6 6	5.2 6	1.64 6	3.2 1	5.2 6	1.81 1	2.9 6	5.10 3	1.9 3	2.6 4	4.3 1	1.8 7	2.3 0	4.2 8	2.0 6	2.0 7	3.9 4	2.1 2	1.8 6	/	/	/
0	5.99	1.20	4.9 8	5.8 0	1.3 1	4.4 3	5.7 4	1.47 3	3.8 9	6.2 6	1.81 3	3.4 7	6.06 7	1.9 2	3.1 5	5.3 6	2.1 2	2.5 5	4.7 4	2.2 5	2.1 6	4.4 9	2.2 6	1.9 9	/	/	/
5	6.43	1.16	5.5 6	6.0 1	1.3 4	4.6 6	6.1 1	1.39 4	4.4 2	6.3 6	1.68 8	3.7 8	6.13 8	1.7 8	3.4 5	5.7 6	1.9 9	2.8 0	5.4 3	2.1 4	2.5 0	5.0 1	2.1 9	2.2 3	4.0 3	2.0	1.9
7	6.75	1.09	6.1 8	6.3 0	1.2 1	5.2 1	6.2 0	1.24 0	5.0 4	6.4 4	1.55 1	4.1 4	6.35 9	1.6 9	3.7 6	6.1 3	1.8 6	3.2 3	6.0 0	2.0 0	3.0 4	5.6 7	2.1 4	2.6 0	4.4 0	2.0	2.1
10	6.68	1.02	6.5 2	6.2 2	1.1 3	5.4 9	6.4 9	1.26 9	5.1 7	6.5 9	1.50 4	4.3 9	6.62 3	1.7 3	3.8 7	6.4 8	1.8 4	3.4 4	6.0 4	1.9 4	3.1 4	5.7 6	2.1 5	2.6 4	4.5 4	1.9	2.3
15	6.52	0.94	6.9 3	6.3 7	1.0 2	6.2 4	6.4 8	1.16 8	5.5 2	7.0 3	1.43 7	4.9 3	6.98 2	1.6 1	4.3 2	6.7 6	1.7 5	3.8 6	6.1 5	1.8 0	3.4 2	5.5 9	2.0 7	2.7 4	5.0 4	1.8	2.7
20	6.34	0.81	7.8 5	6.2 1	0.9 1	6.7 7	6.2 9	1.00 9	6.2 5	6.5 5	1.30 8	5.0 3	6.82 8	1.4 8	4.6 4	6.8 4	1.6 4	5.2 5	6.0 3	1.6 3	0.2 0	5.5 8	1.8 2	3.0 7	5.5 2	1.8	2.7
25	5.97	0.65	9.2 1	6.1 2	0.7 8	7.7 3	6.1 3	0.91 3	6.7 5	6.1 1	1.11 5	5.5 3	6.76 3	1.3 5	4.9 9	7.0 1	1.4 2	4.7 9	5.9 3	1.4 3	4.2 0	5.6 5	1.5 7	3.5 9	/	/	/
30	6.04	0.57	10.1 6	6.2 4	0.7 1	8.7 9	6.2 9	0.80 9	7.8 0	6.1 0	0.93 5	6.5 4	6.64 4	1.2 4	5.3 5	6.6 4	1.2 6	5.2 8	6.0 5	1.3 6	4.4 2	5.7 7	1.4 1	3.9 1	/	/	/
35	6.14	0.53	11.1 6	6.3 1	0.6 1	10.4 6	6.4 6	0.73 6	8.8 7	6.0 4	0.81 4	7.5 4	6.55 3	1.1 3	5.7 3	6.2 9	1.1 2	5.6 2	6.0 3	1.2 2	4.7 5	/	/	/	/	/	/
40	6.66	0.52	12.1 9	6.6 9	0.5 9	11.1 9	6.5 6	0.67 6	9.8 9	6.4 9	0.80 1	8.1 1	6.78 3	1.0 3	6.5 3	6.5 6	1.0 9	6.1 9	/	/	/	/	/	/	/	/	/
43	6.97	0.51	13.1 7	6.9 8	0.5 7	12.1 2	6.8 0	0.63 0	10.6 9	6.9 1	0.75 0	9.2 0	7.09 3	0.9 1	7.6 4	6.8 5	1.0 4	6.5 4	/	/	/	/	/	/	/	/	/
Minimum																											
DB	LWT																										

# S-Therm Yukon split series



	25			30			35			40			45			50			55			60			65		
	HC	PI	COP	HC	PI	COP	HC	PI	COP	HC	PI	COP	HC	PI	COP	HC	PI	COP	HC	PI	COP	HC	PI	COP	HC	PI	COP
-25	1.54	0.86	1.78	1.39	0.91	1.53	1.48	1.12	1.33	1.11	0.76	1.19	1.09	0.99	1.08	/	/	/	/	/	/	/	/	/	/	/	/
-20	2.04	0.82	2.47	1.80	0.96	1.87	1.67	1.11	1.44	1.16	0.84	1.64	1.28	1.14	1.27	1.14	1.33	1.09	1.33	1.33	1.0	/	/	/	/	/	/
-15	2.07	0.65	3.18	2.03	0.70	2.90	1.90	0.76	2.49	2.0	0.92	2.0	1.9	1.2	1.58	1.86	1.35	1.39	1.53	1.24	1.2	1.51	1.41	1.07	/	/	/
-10	2.28	0.62	3.71	2.14	0.63	3.20	2.0	0.77	2.74	2.5	1.07	2.3	2.8	1.3	2.14	2.8	1.57	1.78	2.63	1.5	1.7	2.38	1.64	1.47	/	/	/
-7	1.57	0.39	4.03	1.45	0.41	3.58	1.4	0.4	3.08	2.4	0.92	2.7	2.6	1.0	2.48	2.5	1.2	2.11	2.64	1.3	2.0	2.68	1.47	1.82	/	/	/
-5	1.78	0.41	4.32	1.66	0.44	3.71	1.7	0.5	3.32	2.5	0.87	2.9	2.8	1.0	2.69	2.5	1.1	2.35	2.81	1.3	2.1	2.73	1.49	1.9	/	/	/
0	1.74	0.34	5.15	1.82	0.40	4.57	1.7	0.4	4.02	2.9	0.82	3.5	3.0	0.9	3.29	2.9	1.1	2.59	2.83	1.3	2.1	3.07	1.4	2.0	/	/	/
5	2.31	0.40	5.78	2.32	0.48	4.83	2.3	0.5	4.59	3.2	0.8	3.9	3.2	0.9	3.54	3.4	1.1	2.98	3.46	1.3	2.6	3.52	1.5	2.3	2.8	1.42	2.0
7	2.71	0.42	6.44	2.65	0.4	5.37	2.7	0.5	5.33	3.3	0.7	4.3	3.8	0.9	3.84	4.2	1.2	3.41	4.34	1.4	3.1	4.25	1.5	2.6	3.3	1.49	2.2
10	2.27	0.33	6.83	2.08	0.3	5.75	2.3	0.4	5.43	3.3	0.7	4.6	3.9	0.9	3.9	4.2	1.1	3.57	4.37	1.3	3.2	4.25	1.5	2.7	3.5	1.46	2.4
15	2.81	0.3	7.31	2.83	0.4	6.58	2.8	0.4	5.83	3.6	0.6	5.2	4.2	0.9	4.5	4.4	1.1	4.05	5.03	1.4	3.5	4.36	1.5	2.8	3.8	1.33	2.9
20	3.12	0.3	8.30	3.41	0.4	7.18	3.7	0.5	6.65	4.5	0.8	5.3	4.6	0.9	4.8	4.7	1.0	4.46	4.56	1.1	3.9	4.0	1.2	3.2	/	/	/
25	3.68	0.3	9.73	3.97	0.4	8.24	4.2	0.5	7.14	4.8	0.8	5.8	5.1	0.9	5.2	5.5	1.1	4.96	4.76	1.0	4.4	4.3	1.1	3.7	/	/	/
30	3.88	0.3	11.2	4.20	0.4	9.37	4.4	0.5	8.33	4.4	0.6	6.9	5.1	0.9	5.6	5.3	0.9	5.55	4.91	1.0	4.6	4.5	1.1	4.1	/	/	/
35	4.55	0.3	12.3	4.71	0.4	11.07	4.5	0.4	9.49	4.4	0.5	7.9	5.1	0.8	6.0	5.1	0.8	5.92	5.13	1.0	4.9	/	/	/	/	/	/
40	4.93	0.3	13.6	4.94	0.4	11.97	5.1	0.4	10.54	5.1	0.6	8.5	5.5	0.8	6.9	5.6	0.8	6.50	/	/	/	/	/	/	/	/	/
43	5.20	0.3	14.4	5.20	0.4	13.07	5.3	0.4	11.54	5.4	0.5	9.7	5.9	0.7	8.0	5.9	0.8	6.87	/	/	/	/	/	/	/	/	/

Abbreviations:

LWT: Leaving water temperature (°C)

DB: Dry-bulb temperature for Outdoor air temperature (°C)

HC: Total heating capacity (kW)

PI: Power input (kW)

Table 2-5.3: Heating capacity for MSH-80EB

DB	Maximum																										
	LWT																										
	25			30			35			40			45			50			55			60			65		
	HC	PI	COP	HC	PI	COP	HC	PI	COP	HC	PI	COP	HC	PI	COP	HC	PI	COP	HC	PI	COP	HC	PI	COP	HC	PI	COP
-25	4.45	1.98	2.25	4.00	2.04	1.96	3.59	2.19	1.64	3.34	2.15	1.55	2.81	2.17	1.30	/	/	/	/	/	/	/	/	/	/	/	/
-20	5.68	2.03	2.80	5.09	2.15	2.37	4.74	2.24	2.11	4.32	2.44	1.77	3.70	2.29	1.61	3.17	2.26	1.41	2.62	2.10	1.25	/	/	/	/	/	/
-15	6.90	2.07	3.34	6.44	2.24	2.87	6.11	2.51	2.43	5.57	2.47	2.26	5.29	2.65	2.00	4.67	2.70	1.73	4.94	2.92	1.60	3.99	2.84	1.41	/	/	/
-10	7.45	2.02	3.68	7.28	2.18	3.33	7.08	2.25	3.15	6.87	2.63	2.62	6.77	2.74	2.47	6.32	2.88	2.20	6.07	3.05	1.99	5.19	2.86	1.81	/	/	/
-7	7.64	2.03	3.76	7.47	2.20	3.40	7.27	2.26	3.21	7.05	2.64	2.67	6.94	2.76	2.52	6.48	2.89	2.24	6.22	3.07	2.03	5.32	2.88	1.85	/	/	/
-5	8.05	2.00	4.02	7.97	2.16	3.69	7.69	2.39	3.22	7.45	2.57	2.90	7.44	2.77	2.69	7.35	2.99	2.46	6.45	2.94	2.19	6.04	3.00	2.02	/	/	/
0	8.24	1.73	4.77	8.55	2.02	4.23	8.49	2.25	3.77	8.40	2.53	3.32	8.09	2.75	2.94	8.11	2.95	2.75	7.10	2.99	2.38	6.85	3.16	2.17	/	/	/
5	8.86	1.49	5.95	8.95	1.81	4.94	9.03	1.98	4.56	8.78	2.29	3.84	8.69	2.57	3.98	8.30	2.76	3.00	7.56	2.74	2.38	7.11	2.89	2.46	3.89	3.27	1.19
7	9.51	1.45	6.54	9.20	1.73	5.32	9.11	1.80	5.07	8.85	2.12	4.18	8.98	2.35	3.82	8.43	2.66	3.17	7.80	2.50	3.12	7.24	2.66	2.72	4.08	3.00	1.36
10	10.1	1.35	7.44	9.28	1.59	5.84	8.94	1.65	5.42	8.70	2.02	4.30	8.74	2.24	3.90	8.28	2.42	3.42	8.20	2.48	3.31	7.50	2.72	2.76	5.59	2.65	2.11
15	9.86	1.12	8.79	9.39	1.33	7.09	9.09	1.51	6.04	9.07	1.77	5.12	8.91	2.03	4.38	8.41	2.23	3.77	8.32	2.34	3.55	7.68	2.49	3.09	5.71	2.39	2.39
20	9.65	0.95	10.1	9.51	1.14	8.33	9.33	1.32	7.09	9.45	1.59	5.93	9.08	1.81	5.02	8.53	2.02	4.22	8.43	2.12	3.97	7.86	2.27	3.46	/	/	/
25	9.42	0.90	10.4	9.00	1.03	8.75	8.75	1.15	7.64	9.15	1.44	6.34	9.01	1.55	5.80	8.61	1.87	4.61	8.09	1.90	4.25	7.46	2.01	3.72	/	/	/
30	9.18	0.83	11.0	8.49	0.93	9.16	8.17	1.05	7.78	8.85	1.29	6.84	8.93	1.43	6.23	8.68	1.74	4.99	7.84	1.73	4.53	7.07	1.78	3.98	/	/	/
35	9.55	0.84	11.3	8.83	0.93	9.45	8.50	1.06	8.05	9.20	1.31	7.05	9.29	1.46	6.34	9.03	1.73	5.21	8.16	1.80	4.72	/	/	/	/	/	/
40	10.0	0.87	11.6	9.27	0.93	10.0	8.92	1.05	8.49	9.66	1.32	7.31	9.75	1.51	6.46	9.48	1.74	5.46	/	/	/	/	/	/	/	/	/
43	10.3	0.84	12.3	9.55	0.85	11.3	9.19	1.01	9.11	9.95	1.27	7.86	10.0	1.47	6.83	9.77	1.61	6.08	/	/	/	/	/	/	/	/	/

DB	Normal																										
	LWT																										
	25			30			35			40			45			50			55			60			65		
	HC	PI	COP	HC	PI	COP	HC	PI	COP	HC	PI	COP	HC	PI	COP	HC	PI	COP	HC	PI	COP	HC	PI	COP	HC	PI	COP
-25	4.11	1.79	2.29	3.68	1.82	2.03	3.27	1.96	1.67	3.10	1.99	1.56	2.64	2.05	1.29	/	/	/	/	/	/	/	/	/	/	/	/
-20	5.20	1.79	2.90	4.63	1.90	2.43	4.27	1.97	2.17	3.96	2.20	1.80	3.43	2.11	1.62	2.96	2.08	1.42	2.52	2.00	1.25	/	/	/	/	/	/
-15	6.24	1.79	3.49	5.80	1.95	2.98	5.45	2.15	2.53	5.04	2.18	2.32	4.69	2.31	2.03	4.16	2.36	1.76	4.55	2.65	1.72	3.72	2.64	1.41	/	/	/
-10	6.66	1.71	3.89	6.48	1.86	3.49	6.25	1.92	3.26	6.16	2.30	2.68	6.14	2.46	2.50	5.75	2.58	2.23	5.53	2.75	2.01	4.78	2.65	1.81	/	/	/
-7	7.27	1.83	3.97	7.11	2.01	3.53	7.10	2.18	3.25	6.71	2.40	2.79	6.60	2.59	2.55	6.17	2.67	2.31	6.15	3.00	2.05	5.07	2.69	1.89	/	/	/
-5	7.25	1.71	4.25	7.11	1.86	3.83	6.69	2.00	3.35	6.56	2.14	3.06	6.49	2.33	2.79	6.29	2.48	2.54	5.56	2.46	2.26	5.38	2.62	2.05	/	/	/
0	7.60	1.55	4.89	7.78	1.79	4.34	7.67	1.98	3.88	7.74	2.30	3.37	7.16	2.35	3.05	7.39	2.64	2.79	6.33	2.63	2.41	6.03	2.78	2.17	/	/	/

5	8.09	1.31	6.17	8.08	1.58	5.13	8.08	1.71	4.73	8.03	2.04	3.93	7.62	2.15	3.54	7.50	2.43	3.09	6.68	2.37	2.82	6.21	2.50	2.49	3.32	2.72	1.22		
7	8.60	1.26	6.84	8.21	1.47	5.57	8.30	1.60	5.20	8.00	1.84	4.34	8.20	2.08	3.95	7.53	2.29	3.29	7.50	2.36	3.18	6.25	2.25	2.77	3.44	2.46	1.40		
10	9.05	1.14	7.93	8.12	1.33	6.12	7.89	1.41	5.58	7.77	1.74	4.48	7.91	2.00	3.95	7.65	2.18	3.51	7.14	2.11	3.38	6.89	2.45	2.81	4.92	2.27	2.16		
15	8.96	0.93	9.59	8.32	1.09	7.60	8.11	1.27	6.37	8.20	1.50	5.46	8.15	1.79	4.55	7.85	1.98	3.96	7.33	1.99	3.68	7.13	2.24	3.19	5.19	2.11	2.46		
20	8.82	0.79	11.1	8.46	0.94	9.00	8.37	1.11	7.53	8.58	1.35	6.37	8.36	1.59	5.25	8.01	1.79	4.47	7.47	1.80	4.14	7.34	2.11	3.47	/	/	/		
25	8.39	0.73	11.6	8.17	0.86	9.52	8.01	0.98	8.18	8.47	1.23	6.86	8.44	1.38	6.11	8.23	1.68	4.91	7.31	1.64	4.47	7.10	1.89	3.76	/	/	/		
30	8.23	0.67	12.3	7.75	0.77	10.0	7.52	0.90	8.39	8.24	1.11	7.46	8.42	1.27	6.61	8.35	1.56	5.36	7.13	1.49	4.80	6.77	1.67	4.06	/	/	/		
35	8.63	0.68	12.7	8.13	0.78	10.4	7.89	0.90	8.74	8.64	1.12	7.74	8.83	1.30	6.77	8.75	1.55	5.63	7.48	1.49	5.03	/	/	/	/	/	/		
40	9.20	0.70	13.1	8.39	0.75	11.1	8.04	0.87	9.28	8.81	1.09	8.08	9.01	1.30	6.95	8.94	1.50	5.95	/	/	/	/	/	/	/	/	/		
43	9.56	0.69	13.9	8.72	0.69	12.6	8.36	0.83	10.0	9.16	1.05	8.74	9.36	1.26	7.40	9.28	1.39	6.67	/	/	/	/	/	/	/	/	/		
<b>Minimum</b>																													
DB	<b>LWT</b>																												
	25			30			35			40			45			50			55			60			65				
	HC	PI	COP	HC	PI	COP	HC	PI	COP	HC	PI	COP	HC	PI	COP	HC	PI	COP	HC	PI	COP	HC	PI	COP	HC	PI	COP	HC	PI
-25	2.67	1.15	2.33	2.48	1.21	2.06	2.48	1.46	1.69	2.37	1.50	1.58	1.77	1.37	1.29	/	/	/	/	/	/	/	/	/	/	/	/	/	
-20	3.18	1.08	2.96	2.78	1.11	2.48	2.75	1.24	2.22	2.76	1.51	1.83	2.29	1.40	1.64	2.19	1.52	1.44	1.91	1.51	1.27	/	/	/	/	/	/	/	
-15	3.22	0.90	3.58	3.12	1.03	3.05	2.91	1.12	2.59	3.12	1.31	2.37	3.38	1.64	2.06	3.22	1.80	1.79	3.36	1.92	1.75	2.84	1.99	1.43	/	/	/	/	
-10	2.96	0.74	4.01	2.84	0.79	3.59	2.80	0.84	3.35	3.57	1.30	2.76	4.10	1.61	2.55	4.29	1.88	2.28	4.20	2.05	2.05	3.72	2.02	1.84	/	/	/	/	
-7	1.83	0.45	4.09	1.72	0.47	3.63	1.82	0.53	3.44	3.12	1.07	2.90	3.41	1.28	2.67	3.38	1.44	2.35	3.57	1.67	2.13	3.42	1.78	1.92	/	/	/	/	
-5	2.19	0.50	4.37	2.09	0.53	3.94	2.17	0.63	3.44	3.23	1.03	3.15	3.60	1.27	2.84	3.78	1.46	2.59	3.65	1.59	2.30	3.71	1.77	2.09	/	/	/	/	
0	2.21	0.44	5.06	2.44	0.54	4.49	2.37	0.59	4.01	3.62	1.04	3.48	3.57	1.14	3.12	4.12	1.44	2.86	3.80	1.54	2.47	4.06	1.83	2.22	/	/	/	/	
5	2.90	0.45	6.41	3.10	0.58	5.32	3.06	0.62	4.91	4.05	0.99	4.08	4.09	1.12	3.64	4.47	1.41	3.18	4.28	1.47	2.91	4.43	1.73	2.56	2.47	1.99	1.24	1.2	
7	3.40	0.48	7.14	3.46	0.60	5.81	3.36	0.61	5.54	4.17	0.92	4.53	4.85	1.17	4.15	5.23	1.54	3.40	4.95	1.49	3.33	4.76	1.66	2.87	2.69	1.89	1.4	1.4	
10	3.08	0.37	8.30	2.72	0.42	6.41	2.83	0.48	5.85	3.92	0.83	4.70	4.73	1.15	4.11	4.99	1.37	3.65	5.17	1.47	3.51	5.02	1.72	2.92	3.80	1.72	2.2	2.2	
15	3.86	0.38	10.1	3.69	0.46	8.03	3.55	0.53	6.73	4.20	0.73	5.76	4.94	1.04	4.77	5.19	1.25	4.15	5.99	1.55	3.86	5.60	1.74	3.23	3.82	1.52	2.5	2.5	
20	4.34	0.37	11.8	4.66	0.49	9.52	4.94	0.62	7.98	5.95	0.88	6.74	5.63	1.02	5.51	5.55	1.18	4.69	5.65	1.30	4.35	5.26	1.44	3.65	/	/	/	/	
25	5.18	0.42	12.2	5.31	0.53	10.1	5.51	0.64	8.66	6.68	0.92	7.26	6.48	1.01	6.42	6.46	1.25	5.16	5.81	1.24	4.69	5.45	1.38	3.96	/	/	/	/	
30	5.28	0.41	13.0	5.22	0.49	10.6	5.35	0.60	8.88	6.06	0.77	7.89	6.56	0.94	6.95	6.73	1.20	5.63	5.83	1.16	5.04	5.34	1.25	4.27	/	/	/	/	
35	6.40	0.48	13.4	6.00	0.54	11.0	5.58	0.60	9.26	6.35	0.77	8.20	6.87	0.96	7.12	7.22	1.22	5.92	6.36	1.20	5.29	/	/	/	/	/	/	/	
40	6.82	0.49	13.8	6.21	0.53	11.8	6.34	0.64	9.84	6.96	0.81	8.56	7.41	1.01	7.31	7.68	1.23	6.25	/	/	/	/	/	/	/	/	/	/	
43	7.13	0.48	14.7	6.49	0.49	13.4	6.62	0.62	10.6	7.27	0.78	9.26	7.83	1.01	7.78	8.11	1.16	7.01	/	/	/	/	/	/	/	/	/	/	

**Abbreviations:**

LWT: Leaving water temperature (°C)

DB: Dry-bulb temperature for Outdoor air temperature (°C)

HC: Total heating capacity (kW)

PI: Power input (kW)

**Table 2-5.4: Heating capacity for MSH-100EB**

<b>Maximum</b>																													
DB	<b>LWT</b>																												
	25			30			35			40			45			50			55			60			65				
	HC	PI	COP	HC	PI	COP	HC	PI	COP	HC	PI	COP	HC	PI	COP	HC	PI	COP	HC	PI	COP	HC	PI	COP	HC	PI	COP	HC	PI
-25	4.68	2.06	2.27	4.21	2.12	1.98	3.78	2.28	1.66	3.52	2.24	1.57	2.96	2.26	1.31	/	/	/	/	/	/	/	/	/	/	/	/	/	
-20	5.98	2.12	2.85	5.34	2.24	2.39	4.98	2.32	2.15	4.55	2.59	1.73	3.89	2.31	1.64	3.34	2.35	1.4	2.75	2.18	1.26	/	/	/	/	/	/	/	
-15	7.26	2.15	3.37	6.78	2.34	2.90	6.42	2.62	2.46	5.82	2.52	2.27	5.57	2.2	2.0	4.92	1.7	5.24	3.0	1.7	4.20	2.96	1.42	/	/	/	/	/	
-10	8.37	2.33	3.60	8.14	2.53	3.22	7.82	2.62	2.97	7.62	2.6	2.9	7.62	2.6	2.9	7.33	3.1	2.3	7.03	3.3	2.1	6.63	3.5	1.85	5.38	3.11	1.7	/	
-7	8.72	2.29	3.8	8.49	2.4	3.4	8.32	2.6	3.1	7.92	2.8	3.1	7.92	2.8	3.1	7.63	3.0	2.5	7.33	3.2	2.2	7.03	3.5	1.95	5.63	3.11	1.8	/	
-5	8.80	2.14	4.1	8.82	2.47	3.6	8.82	2.64	3.3	8.42	2.9	3.8	8.1	3.0	2.6	8.04	3.2	2.4	7.53	3.3	2.2	7.1	3.3	2.2	6.13	3.1	1.9	/	
0	9.03	1.83	4.9	9.36	2.31	4.05	9.56	2.55	3.7	9.25	2.9	3.1	8.83	3.1	2.8	8.82	3.2	2.7	8.1	3.3	2.4	6.9	3.3	2.1	2.1	/	/	/	
5	9.94	1.73	5.7	9.97	2.07	4.8	10.2	2.2	4.5	10.2	2.6	3.8	9.7	2.8	3.4	9.45	3.1	3.0	9.0	3.2	2.7	7.8	3.2	2.4	2.4	4.5	3.30	1.37	
7	10.57	1.74	5.9	10.19	1.97	5.2	10.2	2.0	4.9	10.2	2.5	4.1	10.2	2.7	3.7	9.83	3.0	3.2	9.7	3.2	3.0	8.2	2.9	2.7	2.7	4.8	3.11	1.56	
10	11.22	1.59	7.0	10.18	1.85	5.6	10.19	1.9	5.1	9.92	2.3	4.1	9.82	2.6	3.6	9.59	2.9	3.3	9.5	3.1	3.0	8.2	3.0	2.7	6.4	3.05	2.11	2.11	
15	11.41	1.41	8.1	10.16	1.64	6.4	10.17	1.75	5.9	10.21	1.48	4.8	10.23	1.9	4.2	9.78	2.5	3.8	9.7	2.7	3.5	8.4	2.7	3.1	6.5	2.71	2.43	2.43	

# S-Therm Yukon split series



20	10.8	1.19	9.05	10.85	1.35	7.97	10.77	1.59	6.72	10.77	1.89	5.66	10.33	2.12	4.86	10.00	2.38	4.21	9.85	2.54	3.88	8.90	2.56	3.48	/	/	/
25	9.94	1.04	9.59	10.90	1.17	8.44	9.82	1.38	7.12	9.82	1.64	6.06	9.46	1.84	5.15	9.22	2.07	4.47	9.06	2.21	4.11	8.18	2.22	3.69	/	/	/
30	9.77	0.96	10.90	11.07	1.10	8.79	8.92	1.17	7.95	8.83	1.36	6.72	9.92	1.65	6.15	9.31	1.84	4.98	9.04	1.80	4.80	7.49	1.96	3.83	/	/	/
35	10.22	0.95	10.94	10.43	1.03	9.19	9.25	1.11	8.35	9.23	1.36	6.93	10.33	1.66	6.41	9.69	1.85	5.17	9.42	1.90	4.96	/	/	/	/	/	/
40	10.77	0.93	11.05	11.11	1.01	9.89	9.71	1.11	8.45	9.63	1.37	7.30	10.88	1.66	6.72	10.22	1.85	5.53	/	/	/	/	/	/	/	/	/
43	11.00	0.91	12.00	10.92	0.96	10.10	10.10	0.92	9.95	1.28	8.03	11.27	11.14	1.47	7.58	10.58	1.66	6.25	/	/	/	/	/	/	/	/	/

Normal																											
DB	LWT																										
	25			30			35			40			45			50			55			60			65		
	HC	PI	COP	HC	PI	COP	HC	PI	COP	HC	PI	COP	HC	PI	COP	HC	PI	COP	HC	PI	COP	HC	PI	COP	HC	PI	COP
-25	4.33	1.87	2.22	3.87	1.89	2.05	3.45	2.05	1.68	3.28	2.07	1.57	2.78	2.14	1.30	/	/	/	/	/	/	/	/	/	/	/	/
-20	5.47	1.87	3.37	4.78	1.98	2.45	4.56	2.05	2.20	4.17	2.29	1.82	3.61	2.20	1.64	3.11	2.17	1.45	2.65	2.09	1.27	/	/	/	/	/	/
-15	6.57	1.86	3.30	6.12	2.03	3.05	7.20	2.24	2.53	6.11	2.27	2.34	4.94	2.42	2.04	4.38	2.41	1.78	4.79	2.71	1.73	3.91	2.71	1.45	/	/	/
-10	7.49	1.97	3.81	7.25	2.15	3.37	6.95	2.26	3.08	6.88	2.50	2.78	6.69	2.72	2.54	6.42	2.91	2.16	6.03	3.28	1.83	4.96	2.91	1.71	/	/	/
-7	8.28	2.11	3.92	8.13	2.35	3.58	8.22	2.62	3.17	8.43	2.54	2.93	7.35	2.88	2.57	7.03	3.02	2.34	6.83	3.42	2.05	5.10	4.00	1.84	/	/	/
-5	7.93	1.82	4.35	7.92	2.13	3.76	7.62	2.21	3.47	7.45	2.45	3.04	7.13	2.62	2.78	6.82	2.73	2.59	6.49	2.73	2.38	5.46	2.72	2.01	/	/	/
0	8.33	1.64	5.06	8.52	2.05	4.15	8.63	2.24	3.86	8.53	2.66	3.20	7.87	2.65	2.93	8.03	2.97	2.70	7.30	2.85	2.56	6.16	2.91	2.11	/	/	/
5	9.09	1.53	5.95	9.01	1.89	4.99	9.07	1.94	4.68	9.23	2.35	3.92	8.58	2.41	3.55	8.52	2.73	3.02	8.02	2.82	2.86	6.86	2.74	2.43	3.86	2.7	1.4
7	10.2	1.69	6.09	9.98	1.85	5.40	10.00	2.00	5.00	10.10	2.37	4.29	10.0	2.63	3.89	9.52	2.93	3.28	9.53	3.03	3.17	7.70	2.82	2.43	4.2	2.6	1.6
10	10.1	1.34	7.50	9.12	1.55	5.98	8.85	1.68	5.28	8.88	2.04	4.35	8.94	2.40	3.78	8.82	2.63	3.36	8.34	2.65	3.17	7.60	2.77	5.62	2.6	2.1	6
15	10.3	1.18	8.83	9.45	1.36	6.99	9.13	1.47	6.22	9.16	1.79	5.12	9.22	2.10	4.38	9.12	2.23	3.99	8.60	2.36	3.67	7.84	2.43	5.97	2.3	2.5	9
20	9.88	0.99	9.94	9.51	1.10	8.69	9.51	1.34	7.14	9.77	1.60	6.08	9.46	1.85	5.01	9.42	2.14	4.43	8.73	2.14	4.63	8.33	2.34	3.48	/	/	/
25	8.86	0.83	10.68	8.98	0.91	9.18	8.99	1.18	7.63	9.11	1.40	6.49	8.87	1.63	5.43	8.82	1.85	4.75	8.19	1.84	4.37	7.79	2.03	3.7	/	/	/
30	8.76	0.77	11.33	8.26	0.86	9.63	8.10	0.96	8.57	8.22	1.13	7.32	9.35	1.43	6.53	8.93	1.68	5.38	8.21	1.65	5.07	7.18	1.83	3.9	/	/	/
35	9.19	0.76	12.09	8.66	0.81	10.85	0.95	0.90	8.61	1.13	7.65	9.81	1.43	6.83	9.31	1.68	5.59	8.63	1.63	5.29	/	/	/	/	/	/	/
40	9.79	0.75	13.00	9.98	0.81	11.87	0.95	0.92	8.86	1.09	8.11	10.0	1.37	7.39	9.52	1.56	6.09	/	/	/	/	/	/	/	/	/	/
43	10.2	0.74	13.07	9.32	0.79	11.91	0.89	1.0	9.16	1.02	8.97	10.4	1.27	8.21	9.99	1.46	6.85	/	/	/	/	/	/	/	/	/	/

Minimum																											
DB	LWT																										
	25			30			35			40			45			50			55			60			65		
	HC	PI	COP	HC	PI	COP	HC	PI	COP	HC	PI	COP	HC	PI	COP	HC	PI	COP	HC	PI	COP	HC	PI	COP	HC	PI	COP
-25	2.81	1.19	2.35	2.61	1.26	2.0	2.61	1.51	1.72	2.5	1.56	1.6	1.8	1.4	1.3	/	/	/	/	/	/	/	/	/	/	/	/
-20	3.35	1.12	2.99	2.89	1.15	2.50	2.8	1.2	2.22	2.9	1.5	1.8	2.4	1.4	1.6	2.3	1.5	1.45	2.01	1.57	1.2	/	/	/	/	/	/
-15	3.39	0.94	3.61	3.29	1.03	3.0	3.0	1.1	2.63	3.2	1.3	2.4	3.5	1.7	2.0	3.3	1.8	1.81	3.53	2.0	1.7	2.9	2.0	1.4	/	/	/
-10	3.32	0.85	3.91	3.18	0.92	3.4	3.1	0.9	3.1	3.9	1.4	2.8	4.4	1.8	2.4	4.7	2.1	2.20	4.62	2.4	1.9	3.8	2.2	1.7	/	/	/
-7	2.09	0.51	4.14	1.95	0.54	3.6	2.0	0.6	3.3	3.5	1.1	3.0	3.7	1.4	2.6	3.8	1.6	2.36	3.99	1.9	2.0	3.6	1.9	1.8	/	/	/
-5	2.39	0.53	4.48	2.32	0.64	3.8	2.4	0.7	3.5	3.6	1.1	3.1	3.9	1.4	2.8	4.1	1.6	2.58	4.26	1.7	2.3	3.7	1.8	2.0	/	/	/
0	2.42	0.46	5.24	2.68	0.62	4.3	2.6	0.6	3.9	3.9	1.2	3.3	3.9	1.2	3.0	4.4	1.5	2.82	4.38	1.6	2.6	4.1	1.9	2.1	/	/	/
5	3.26	0.53	6.18	3.45	0.67	5.1	3.4	0.7	4.8	4.6	1.1	4.0	4.6	1.2	3.6	5.0	1.6	3.18	5.14	1.7	2.9	4.8	1.9	2.5	2.8	2.02	1.4
7	3.76	0.58	6.48	3.86	0.68	5.6	3.8	0.7	5.3	4.9	1.0	4.5	5.5	1.3	4.0	6.1	1.7	3.46	6.17	1.9	3.2	5.4	1.8	2.9	3.1	1.96	1.6
10	3.43	0.44	7.86	3.05	0.49	6.1	3.1	0.5	5.5	4.4	0.9	4.5	5.3	1.3	3.8	5.7	1.6	3.52	6.04	1.8	3.2	5.5	1.9	2.8	4.3	1.98	2.2
15	4.48	0.48	9.32	4.17	0.57	7.3	4.0	0.6	6.5	4.6	0.8	5.4	5.5	1.2	4.5	6.0	1.4	4.18	7.03	1.8	3.8	6.1	1.8	3.2	4.4	1.71	2.5
20	4.86	0.46	10.5	5.27	0.58	9.1	5.6	0.7	7.5	6.7	1.0	6.4	6.3	1.1	5.3	6.5	1.3	4.68	6.60	1.5	4.2	5.9	1.6	3.6	/	/	/
25	5.47	0.44	11.2	5.84	0.60	9.7	6.1	0.7	8.0	7.1	1.0	6.8	6.8	1.1	5.7	6.9	1.3	5.00	6.51	1.4	4.5	5.9	1.5	3.9	/	/	/
30	5.62	0.44	12.0	5.58	0.55	10.5	5.8	0.6	9.0	6.0	0.7	7.7	7.2	1.0	6.8	7.2	1.2	5.59	6.71	1.2	5.3	5.6	1.3	4.1	/	/	/
35	6.81	0.53	12.7	6.42	0.60	10.7	6.0	0.6	9.5	6.3	0.7	8.1	7.6	1.0	7.1	7.7	1.3	5.88	7.34	1.3	5.5	/	/	/	/	/	/
40	7.26	0.53	13.8	6.64	0.58	11.7	6.9	0.7	9.8	6.9	0.8	8.5	8.2	1.0	7.6	8.2	1.3	6.33	/	/	/	/	/	/	/	/	/
43	7.59	0.53	14.5	6.94	0.56	12.7	7.2	0.6	10.7	7.2	0.7	9.5	8.7	1.0	8.6	8.7	1.2	7.20	/	/	/	/	/	/	/	/	/

**Abbreviations:**

LWT: Leaving water temperature (°C)

DB: Dry-bulb temperature for Outdoor air temperature (°C)

HC: Total heating capacity (kW)

PI: Power input (kW)

Table 2-5.5: Heating capacity for MSH-120EB; MSH-120EB-3

Maximum																													
DB	LWT																												
	25			30			35			40			45			50			55			60			65				
	HC	PI	COP	HC	PI	COP	HC	PI	COP	HC	PI	COP	HC	PI	COP	HC	PI	COP	HC	PI	COP	HC	PI	COP	HC	PI	COP	HC	PI
-25	6.03	2.78	2.17	6.26	2.91	2.15	5.03	2.96	1.70	4.53	3.12	1.45	4.23	3.29	1.28	/	/	/	/	/	/	/	/	/	/	/	/	/	
-20	7.65	3.00	2.55	7.69	3.08	2.50	7.21	3.34	2.16	6.38	3.41	1.87	6.05	3.52	1.72	5.36	3.55	1.51	5.08	3.63	1.40	/	/	/	/	/	/	/	
-15	8.90	3.12	2.85	8.86	3.34	2.65	8.86	3.62	2.45	7.93	3.62	2.19	7.39	3.95	1.87	6.71	3.97	1.69	6.33	4.31	1.47	5.87	4.69	1.25	/	/	/	/	
-10	11.0	3.47	3.17	10.1	3.68	2.74	10.0	3.95	2.54	9.69	4.34	2.23	9.32	4.54	2.05	8.96	4.62	1.94	8.60	4.79	1.79	6.70	5.13	1.30	/	/	/	/	
-7	12.3	3.52	3.49	10.9	3.62	3.02	11.0	3.89	2.83	10.4	4.27	2.44	10.4	4.50	2.31	10.6	4.74	2.24	10.6	5.25	2.02	8.05	5.06	1.59	/	/	/	/	
-5	12.4	3.33	3.71	11.2	3.55	3.15	11.3	3.87	2.92	10.9	4.26	2.57	10.9	4.61	2.37	10.8	4.75	2.27	10.6	5.14	2.05	8.21	5.14	1.60	/	/	/	/	
0	12.5	2.87	4.35	11.9	3.13	3.80	12.0	3.44	3.48	12.3	4.04	3.04	12.3	4.37	2.81	11.1	4.61	2.41	10.8	4.74	2.27	8.52	5.03	1.69	/	/	/	/	
5	14.6	2.66	5.49	13.5	2.97	4.55	13.6	3.28	4.15	13.8	3.70	3.73	13.6	4.18	3.26	12.8	4.46	2.88	12.8	4.70	2.73	11.6	5.06	2.29	9.92	5.16	1.92	/	
7	15.5	2.57	6.00	14.3	2.83	5.04	14.6	3.11	4.69	14.8	3.57	4.14	14.5	4.00	3.63	13.9	4.43	3.14	13.9	4.66	2.97	13.0	5.07	2.56	11.5	5.17	2.23	/	
10	15.0	2.40	6.22	14.4	2.62	5.49	14.3	2.83	5.06	14.6	3.34	4.37	14.3	3.89	3.69	13.5	4.11	3.30	13.1	4.38	2.99	12.7	4.79	2.65	11.7	4.89	2.39	/	
15	15.1	1.97	7.67	14.7	2.21	6.65	14.4	2.65	5.43	15.0	3.17	4.72	14.6	3.53	4.14	13.4	3.73	3.60	12.1	3.97	3.03	12.3	4.32	2.85	11.7	4.42	2.65	/	
20	14.6	1.66	8.76	14.3	1.88	7.60	14.2	2.20	6.47	14.8	2.75	5.39	14.8	3.15	4.69	13.7	3.37	4.06	12.0	3.55	3.39	10.8	3.71	2.90	/	/	/	/	
25	14.4	1.55	9.31	14.3	1.73	8.23	14.2	1.93	7.35	14.7	2.35	6.26	14.7	2.73	5.39	13.9	3.00	4.63	12.0	3.12	3.84	10.0	3.36	2.99	/	/	/	/	
30	14.6	1.45	10.1	14.2	1.62	8.75	14.4	1.85	7.76	14.7	2.22	6.63	14.7	2.63	5.59	14.0	2.82	4.95	12.6	2.94	4.30	10.3	3.40	3.04	/	/	/	/	
35	15.2	1.39	10.9	14.9	1.60	9.29	14.7	1.80	8.16	15.1	2.17	6.95	14.6	2.50	5.83	14.2	2.72	5.24	12.9	2.79	4.62	/	/	/	/	/	/	/	
40	15.7	1.41	11.1	15.6	1.59	9.82	15.4	1.79	8.65	16.0	2.17	7.36	15.3	2.44	6.29	14.5	2.69	5.40	/	/	/	/	/	/	/	/	/	/	
43	16.2	1.35	12.0	16.0	1.50	10.6	15.9	1.73	9.18	16.5	2.11	7.82	16.0	2.35	6.81	14.8	2.57	5.75	/	/	/	/	/	/	/	/	/	/	
Normal																													
DB	LWT																												
	25			30			35			40			45			50			55			60			65				
	HC	PI	COP	HC	PI	COP	HC	PI	COP	HC	PI	COP	HC	PI	COP	HC	PI	COP	HC	PI	COP	HC	PI	COP	HC	PI	COP	HC	PI
-25	5.16	2.24	2.30	5.32	2.32	2.29	4.24	2.37	1.79	3.88	2.57	1.51	3.66	2.82	1.30	/	/	/	/	/	/	/	/	/	/	/	/	/	
-20	6.73	2.45	2.75	6.73	2.49	2.70	6.25	2.72	2.30	5.62	2.85	1.97	5.31	3.01	1.77	4.72	3.03	1.56	4.63	3.30	1.40	/	/	/	/	/	/	/	
-15	7.43	2.41	3.09	7.35	2.55	2.88	7.28	2.78	2.62	6.63	2.86	2.32	6.04	3.13	1.93	5.51	3.14	1.75	5.30	3.58	1.48	4.96	4.01	1.24	/	/	/	/	
-10	9.06	2.69	3.37	8.26	2.83	2.92	8.14	3.06	2.66	8.00	3.45	2.32	7.80	3.70	2.11	7.54	3.77	2.00	7.24	3.91	1.85	5.70	4.30	1.33	/	/	/	/	
-7	11.1	3.11	3.57	10.3	3.26	3.15	10.0	3.33	3.00	10.1	4.06	2.50	10.2	4.25	2.40	10.3	4.48	2.29	10.0	4.88	2.05	7.23	4.42	1.64	/	/	/	/	
-5	10.3	2.55	4.03	9.22	2.72	3.38	9.05	2.89	3.13	8.87	3.19	2.78	8.78	3.48	2.52	8.47	3.59	2.36	8.36	3.91	2.14	6.74	4.10	1.64	/	/	/	/	
0	9.93	2.09	4.75	9.35	2.29	4.09	9.19	2.46	3.74	9.51	2.88	3.30	9.43	3.14	3.00	8.13	3.22	2.52	7.93	3.38	2.34	6.70	3.83	1.75	/	/	/	/	
5	11.8	1.95	6.05	10.8	2.18	4.94	10.6	2.35	4.50	10.8	2.65	4.08	10.6	3.01	3.51	9.75	3.22	3.03	9.83	3.42	2.88	9.21	3.86	2.38	8.19	4.05	2.02	/	
7	12.9	1.96	6.57	11.9	2.19	5.44	12.1	2.44	4.95	12.4	2.75	4.50	12.3	3.24	3.80	12.2	3.75	3.25	12.0	3.87	3.10	10.8	4.06	2.66	9.64	4.10	2.35	/	
10	11.8	1.72	6.88	11.2	1.87	5.99	10.9	1.97	5.51	11.3	2.34	4.81	10.9	2.74	3.99	10.1	2.93	3.44	9.86	3.16	3.13	9.92	3.62	2.74	9.48	3.80	2.49	/	
15	12.0	1.41	8.56	11.6	1.58	7.32	11.0	1.84	5.97	11.6	2.21	5.24	11.2	2.48	4.52	10.1	2.66	3.79	9.12	2.85	3.20	9.66	3.26	2.97	9.57	3.39	2.82	/	
20	11.5	1.16	9.86	11.1	1.32	8.45	10.8	1.50	7.18	11.4	1.89	6.04	11.2	2.17	5.16	10.1	2.35	4.32	9.00	2.50	3.61	8.37	2.74	3.06	/	/	/	/	
25	11.4	1.09	10.5	11.2	1.22	9.15	10.8	1.33	8.15	11.4	1.46	7.79	11.2	1.89	5.93	10.4	2.11	4.93	9.04	2.21	4.09	7.85	2.50	3.14	/	/	/	/	
30	11.7	1.04	11.3	11.2	1.16	9.66	11.0	1.29	8.55	11.5	1.41	8.15	11.4	1.93	5.88	10.5	2.01	5.24	9.62	2.14	4.49	8.17	2.58	3.17	/	/	/	/	
35	12.4	1.02	12.1	12.0	1.17	10.2	11.5	1.32	8.78	12.0	1.60	7.49	11.5	1.86	6.17	11.0	1.96	5.58	10.0	2.06	4.86	/	/	/	/	/	/	/	
40	13.1	1.06	12.4	12.9	1.19	10.9	12.5	1.33	9.37	13.0	1.63	7.99	12.4	1.84	6.71	11.5	1.98	5.80	/	/	/	/	/	/	/	/	/	/	
43	13.7	1.02	13.5	13.4	1.14	11.8	13.0	1.30	10.0	13.7	1.60	8.54	13.1	1.80	7.31	11.9	1.91	6.22	/	/	/	/	/	/	/	/	/	/	
Minimum																													
DB	LWT																												
	25			30			35			40			45			50			55			60			65				
	HC	PI	COP	HC	PI	COP	HC	PI	COP	HC	PI	COP	HC	PI	COP	HC	PI	COP	HC	PI	COP	HC	PI	COP	HC	PI	COP	HC	PI
-25	3.44	1.46	2.36	3.72	1.59	2.35	3.27	1.81	1.81	3.08	2.01	1.53	2.83	2.17	1.30	/	/	/	/	/	/	/	/	/	/	/	/	/	
-20	4.24	1.52	2.78	4.42	1.61	2.74	4.08	1.75	2.33	3.72	1.86	2.00	3.93	2.25	1.75	3.75	2.43	1.54	3.60	2.58	1.39	/	/	/	/	/	/	/	
-15	4.85	1.54	3.16	5.00	1.70	2.94	4.92	1.83	2.68	4.55	1.92	2.37	4.73	2.45	1.93	4.63	2.64	1.75	4.43	2.98	1.49	4.22	3.39	1.25	/	/	/	/	
-10	4.67	1.34	3.49	4.48	1.48	3.03	4.36	1.59	2.74	4.39	1.84	2.38	4.85	2.25	2.15	5.11	2.50	2.04	5.33	2.83	1.89	4.49	3.32	1.35	/	/	/	/	
-7	4.61	1.17	3.94	3.85	1.15	3.36	3.97	1.26	3.14	4.20	1.53	2.74	5.41	2.14	2.52	5.73	2.41	2.37	6.03	2.79	2.16	5.23	3.11	1.68	/	/	/	/	
-5	4.75	1.13	4.19	4.06	1.15	3.53	4.18	1.28	3.26	4.52	1.56	2.90	5.80	2.23	2.61	5.93	2.44	2.43	6.12	2.79	2.20	5.42	3.20	1.69	/	/	/	/	
0	4.99	1.01	4.96	4.64	1.08	4.28	4.62	1.18	3.92	5.24	1.52	3.45	6.70	2.15	3.11	6.12	2.49	2.45	6.23	2.69	2.32	5.75	3.18	1.81	/	/	/	/	
5	5.91	0.93	6.35	5.34	1.03	5.19	5.31	1.12	4.73	5.97	1.39	4.29	7.49	2.05	3.66	7.30	2.32	3.15	8.08	2.71	2.98	7.87	3.18	2.48	6.99	3.33	2.10	/	
7	6.15	0.88	6.98	5.53	0.96	5.79	5.58	1.04	5.38	6.30	1.31	4.80	7.88	1.92	4.10	7.83	2.26	3.46	8.63	2.64	3.27	8.71	3.13	2.79	8.06	3.28	2.46	/	
10	6.10	0.84	7.24	5.72	0.91	6.31	5.62	0.97	5.81	6.37	1.26	5.07	7.92	1.90	4.16	7.76	2.13	3.63	8.30	2.54	3.27	8.68	3.03	2.87	8.28	3.17	2.61	/	
15	5.93	0.66	8.96	5.78	0.75	7.68	5.62	0.90	6.26	6.92	1.26	5.49	8.09	1.72	4.69	8.28	2.08	3.98	7.83	2.35	3.33	8.73	2.83	3.09	8.62	2.95	2.92	/	
20	5.81	0.56	10.3	5.73	0.65	8.85	5.66	0.75	7.52	6.97																			

# S-Therm Yukon split series



Abbreviations:

LWT: Leaving water temperature (°C)

DB: Dry-bulb temperature for Outdoor air temperature (°C)

HC: Total heating capacity (kW)

PI: Power input (kW)

Table 2-5.6: Heating capacity for MSH-140EB, MSH-140EB-3

Maximum																														
DB	LWT																													
	25			30			35			40			45			50			55			60			65					
	HC	PI	COP	HC	PI	COP	HC	PI	COP	HC	PI	COP	HC	PI	COP	HC	PI	COP	HC	PI	COP	HC	PI	COP	HC	PI	COP			
-25	6.6	3.0	2.1	6.7	3.2	2.1	5.4	3.1	1.7	4.8	3.3	1.4	4.4	3.4	1.2	/	/	/	/	/	/	/	/	/	/	/	/	/	/	/
-20	8.2	3.2	2.5	8.3	3.3	2.5	7.7	3.5	2.1	6.8	3.6	1.8	6.2	3.6	1.7	5.4	3.6	1.5	5.1	3.8	1.3	/	/	/	/	/	/	/	/	/
-15	9.6	3.4	2.8	9.5	3.6	2.6	9.5	3.9	2.4	8.5	3.9	2.1	7.6	4.1	1.8	7.0	4.3	1.6	6.4	4.5	1.4	6.0	5.0	1.1	/	/	/	/	/	/
-10	11.1	3.8	3.1	11.1	4.1	2.7	11.1	4.4	2.4	10.4	4.7	2.2	9.6	4.7	2.0	9.0	5.0	1.8	8.7	5.2	1.6	6.7	5.3	1.2	/	/	/	/	/	/
-7	13.7	4.0	3.4	12.4	4.2	3.0	12.4	4.5	2.7	12.4	4.9	2.4	11.7	5.1	2.3	11.1	5.3	2.0	11.1	5.4	2.0	8.0	5.3	1.5	/	/	/	/	/	/
-5	13.9	3.7	3.6	13.3	3.8	3.4	12.4	4.1	2.9	12.4	4.6	2.7	12.4	4.9	2.4	11.1	5.2	2.1	11.1	5.3	2.0	8.2	5.0	1.6	/	/	/	/	/	/
0	14.3	3.4	4.2	13.3	3.5	3.8	12.3	3.8	3.2	13.4	4.3	3.0	12.4	4.8	2.6	11.1	4.9	2.3	11.1	5.1	2.2	9.3	5.4	1.7	/	/	/	/	/	/
5	15.4	2.9	5.2	14.3	3.3	4.5	14.3	3.6	3.9	14.3	3.9	3.6	14.3	4.5	3.1	13.4	4.9	2.7	13.4	5.1	2.6	11.1	5.3	2.1	9.7	5.33	1.83			
7	16.3	2.8	5.8	15.3	3.1	4.9	15.3	3.3	4.5	15.3	3.8	4.0	15.3	4.3	3.6	15.3	4.8	3.1	14.4	4.9	2.9	13.4	5.2	2.5	10.4	4.95	2.10			
10	15.5	2.2	6.8	15.3	2.8	5.3	14.3	3.1	4.7	15.3	3.6	4.2	15.3	4.0	3.6	15.3	4.6	3.3	14.4	4.6	3.0	13.4	4.9	2.6	11.1	4.98	2.26			
15	15.3	2.0	7.6	15.3	2.6	5.7	15.3	2.9	5.1	15.3	3.5	4.4	15.3	3.9	3.8	15.3	4.3	3.5	13.4	4.0	3.2	12.4	4.4	2.8	11.1	4.97	2.41			
20	14.1	1.7	8.3	14.3	2.2	6.7	14.3	2.5	5.6	15.3	3.0	5.0	15.3	3.4	4.4	15.3	3.8	3.9	12.4	3.6	3.5	11.1	3.7	2.9	/	/	/			
25	14.1	1.6	9.0	14.3	1.9	7.6	14.3	2.3	6.1	14.3	2.6	5.5	14.3	2.9	4.9	14.3	3.4	4.3	12.4	3.2	3.8	10.4	3.4	2.9	/	/	/			
30	13.5	1.5	9.8	14.3	1.8	8.2	14.3	2.1	7.0	15.3	2.4	6.2	15.3	2.8	5.3	14.3	3.1	4.6	12.4	2.9	4.3	10.4	3.4	3.0	/	/	/			
35	16.0	1.4	11.1	15.3	1.7	9.0	15.3	1.8	8.0	15.3	2.2	6.8	15.3	2.6	5.7	14.3	2.9	5.0	13.4	2.7	4.6	/	/	/	/	/	/			
40	16.2	1.4	11.1	16.3	1.5	10.1	16.3	1.8	8.5	16.3	2.2	7.2	15.3	2.5	6.0	15.3	2.7	5.3	/	/	/	/	/	/	/	/	/			
43	16.5	1.3	12.1	16.3	1.5	10.1	16.3	1.8	8.8	16.3	2.1	7.6	16.3	2.5	6.2	15.3	2.7	5.5	/	/	/	/	/	/	/	/	/			

Normal																											
DB	LWT																										
	25			30			35			40			45			50			55			60			65		
	HC	PI	COP	HC	PI	COP	HC	PI	COP	HC	PI	COP	HC	PI	COP	HC	PI	COP	HC	PI	COP	HC	PI	COP	HC	PI	COP
-25	5.65	2.48	2.2	5.7	2.5	2.2	4.5	2.55	1.7	4.1	2.76	1.5	3.88	2.9	1.3	/	/	/	/	/	/	/	/	/	/	/	/
-20	7.27	2.63	2.7	7.2	2.6	2.7	6.7	2.92	2.3	6.0	3.06	1.9	5.48	3.0	1.7	4.7	3.0	1.5	4.6	3.5	1.3	/	/	/	/	/	/
-15	8.03	2.63	3.0	7.9	2.7	2.8	7.8	3.03	2.6	7.1	3.12	2.2	6.24	3.2	1.9	5.7	3.4	1.6	5.4	3.8	1.4	5.0	4.3	1.1	/	/	/
-10	9.80	2.96	3.3	9.3	3.2	2.9	8.8	3.43	2.5	8.7	3.74	2.3	8.07	3.8	2.0	7.6	4.0	1.8	7.3	4.2	1.7	5.7	4.4	1.2	/	/	/
-7	12.7	3.56	3.5	12.3	3.9	3.0	12.4	4.29	2.8	11.4	4.46	2.6	11.8	5.0	2.3	10.5	5.1	2.1	11.1	5.3	2.0	7.4	4.7	1.5	/	/	/
-5	11.6	2.89	4.0	10.8	2.9	3.6	9.9	3.11	3.2	10.3	3.45	2.9	9.68	3.7	2.5	8.7	3.9	2.2	8.8	4.0	2.1	6.7	4.0	1.6	/	/	/
0	11.4	2.48	4.5	10.2	2.5	4.1	9.5	2.72	3.5	10.3	3.08	3.2	9.74	3.4	2.7	8.7	3.6	2.4	8.7	3.7	2.3	7.1	4.0	1.7	/	/	/
5	12.4	2.15	5.7	11.2	2.4	4.9	11.1	2.60	4.2	11.1	2.83	3.9	11.1	3.3	3.3	10.3	3.6	2.9	10.3	3.7	2.8	9.3	4.1	2.2	8.0	4.1	1.9
7	15.2	2.43	6.2	14.2	2.7	5.2	14.3	3.09	4.7	14.3	3.52	4.1	14.2	3.8	3.6	14.4	4.4	3.1	13.4	4.6	3.0	12.4	2.6	9.7	4.5	2.1	0.6
10	12.3	1.63	7.5	12.0	2.0	5.8	11.1	2.17	5.2	11.1	2.52	4.6	11.4	2.8	3.9	11.4	3.3	3.4	10.3	3.3	3.2	10.3	3.7	2.7	9.1	3.8	2.3
15	12.2	1.43	8.5	11.1	1.8	6.3	11.1	2.05	5.6	12.3	2.49	4.9	11.9	2.8	4.2	11.1	3.1	3.7	9.8	2.8	3.4	10.3	3.3	2.9	9.6	3.7	2.5
20	11.7	1.25	9.4	10.5	1.5	7.4	11.1	1.77	6.2	11.1	2.08	5.6	11.5	2.3	4.8	11.1	2.6	4.1	9.5	2.5	3.7	8.5	2.7	3.0	/	/	/
25	11.8	1.15	10.1	11.1	1.3	8.5	11.1	1.63	6.8	11.1	1.66	6.9	11.3	2.0	5.4	11.1	2.4	4.5	9.4	2.3	4.0	7.9	2.5	3.1	/	/	/
30	12.2	1.11	11.1	11.1	1.2	9.0	11.1	1.46	7.8	11.1	1.54	7.6	11.6	2.0	5.6	11.1	2.2	4.9	9.7	2.1	4.5	8.1	2.5	3.1	/	/	/
35	13.0	1.06	12.1	12.1	1.2	9.9	11.1	1.36	8.6	12.1	1.67	7.3	12.0	1.9	6.1	11.1	2.1	5.3	10.0	2.0	4.9	/	/	/	/	/	/
40	13.5	1.04	13.1	13.1	1.1	11.1	13.1	1.41	9.2	13.1	1.65	7.8	12.7	1.9	6.4	11.1	2.0	5.7	/	/	/	/	/	/	/	/	/
43	14.1	1.02	13.8	14.1	1.1	12.1	13.1	1.41	9.6	13.1	1.61	8.4	13.2	1.9	6.7	12.2	2.0	5.9	/	/	/	/	/	/	/	/	/

Minimum																											
DB	LWT																										
	25			25			25			25			25			25			25			25					
	HC	PI	COP	HC	PI	COP	HC	PI	COP	HC	PI	COP	HC	PI	COP	HC	PI	COP	HC	PI	COP	HC	PI	COP	HC	PI	COP
-25	3.76	1.6	2.33	4.02	1.7	2.3	3.5	1.9	1.8	3.3	2.1	1.5	3.0	2.2	1.3	/	/	/	/	/	/	/	/	/	/	/	/

-20	4.58	1.63	2.80	4.77	1.73	2.76	4.40	1.87	2.35	4.02	1.99	2.02	4.06	2.31	1.76	3.79	2.47	1.54	3.65	2.76	1.32	/	/	/	/	/	/
-15	5.24	1.68	3.13	5.40	1.85	2.91	5.31	2.00	2.66	4.91	2.09	2.39	4.88	2.56	1.94	4.87	2.87	1.68	4.52	3.17	1.43	4.33	3.65	1.19	/	/	/
-10	5.05	1.47	3.44	5.08	1.68	3.04	4.79	1.72	2.64	4.89	1.99	2.45	5.02	2.35	2.15	5.17	2.71	1.90	5.40	3.08	1.76	4.51	3.43	1.32	/	/	/
-7	5.14	1.34	3.84	4.55	1.35	3.37	4.57	1.43	3.14	4.97	1.72	2.86	6.24	2.46	2.59	5.92	2.71	2.20	6.29	2.95	2.15	5.22	3.26	1.60	/	/	/
-5	5.35	1.28	4.17	4.78	1.25	3.81	4.63	1.33	3.33	5.14	1.63	3.07	6.42	2.41	2.61	6.15	2.69	2.28	6.46	2.84	2.25	5.44	3.17	1.74	/	/	/
0	5.73	1.19	4.80	5.34	1.24	4.36	4.73	1.33	3.65	5.51	1.63	3.42	6.92	2.39	2.96	6.67	2.67	2.48	6.90	2.84	2.46	6.12	3.37	1.89	/	/	/
5	6.23	1.03	6.07	5.89	1.14	5.18	5.52	1.24	4.49	6.14	1.49	4.16	7.85	2.25	3.49	7.86	2.59	3.03	8.68	2.98	2.91	7.95	3.32	2.38	6.88	3.44	2.00
7	6.48	0.96	6.75	6.03	1.06	5.68	5.92	1.12	5.27	6.64	1.42	4.68	8.50	2.09	4.07	8.43	2.46	3.43	9.05	2.78	3.25	8.88	3.27	2.75	7.25	3.14	2.31
10	6.34	0.80	7.93	6.18	1.00	6.14	5.84	1.06	5.50	6.66	1.35	4.92	8.20	2.00	4.15	8.77	2.40	3.65	8.96	2.67	3.36	9.02	3.12	2.95	7.95	3.23	2.46
15	6.01	0.66	8.90	5.97	0.88	6.65	5.93	1.00	5.97	7.34	1.42	5.18	8.59	1.94	4.42	9.47	2.43	3.89	8.45	2.38	3.54	9.03	2.93	3.01	8.72	3.29	2.65
20	5.95	0.60	9.84	5.93	0.77	7.85	5.83	0.88	6.57	7.12	1.22	5.88	8.41	1.68	5.06	9.35	2.14	4.36	8.36	2.13	3.87	7.88	2.43	3.17	/	/	/
25	6.09	0.50	10.7	6.05	0.66	8.95	5.93	0.87	7.17	7.17	1.10	6.58	8.41	1.48	5.67	9.33	1.94	4.80	8.32	1.94	4.28	7.38	2.23	3.27	/	/	/
30	7.11	0.62	11.5	7.26	0.77	9.46	8.16	1.00	8.04	8.41	1.27	7.08	8.66	1.45	5.93	9.31	1.85	5.17	8.70	1.84	4.87	7.32	2.23	3.37	/	/	/
35	7.63	0.59	13.0	7.69	0.76	10.83	8.39	0.91	9.18	8.83	1.15	7.88	8.91	1.40	6.47	9.61	1.77	5.61	8.91	1.75	5.19	/	/	/	/	/	/
40	7.89	0.57	13.8	8.37	0.61	12.91	9.09	0.98	9.10	9.10	1.08	8.34	9.21	1.36	6.89	9.82	1.63	6.08	/	/	/	/	/	/	/	/	/
43	8.30	0.57	14.6	8.79	0.61	12.95	9.09	1.00	9.51	10.95	1.07	8.99	9.21	1.37	7.02	10.16	1.63	6.30	/	/	/	/	/	/	/	/	/

Abbreviations:

LWT: Leaving water temperature (°C)

DB: Dry-bulb temperature for Outdoor air temperature (°C)

HC: Total heating capacity (kW)

PI: Power input (kW)

Table 2-5.7: Heating capacity for MSH-160EB, MSH-160EB-3

Maximum																											
DB	LWT																										
	25			30			35			40			45			50			55			60			65		
	HC	PI	COP	HC	PI	COP	HC	PI	COP	HC	PI	COP	HC	PI	COP	HC	PI	COP	HC	PI	COP	HC	PI	COP			
-25	7.69	4.03	1.91	7.99	4.22	1.93	6.61	4.01	1.65	5.89	4.43	1.33	4.96	4.21	1.18	/	/	/	/	/	/	/	/	/	/		
-20	9.57	3.94	2.38	9.71	4.43	2.19	8.16	4.77	1.71	7.48	4.76	1.57	6.55	4.85	1.35	5.85	4.54	1.29	5.37	4.75	1.13	/	/	/	/		
-15	11.8	4.37	2.71	11.3	4.60	2.45	10.7	4.93	2.17	10.1	5.24	1.92	9.03	5.38	1.68	7.53	5.32	1.42	6.82	5.29	1.29	6.42	5.59	1.15	/	/	
-10	13.4	4.51	2.97	13.0	4.78	2.72	12.7	5.09	2.49	12.4	5.43	2.28	11.1	5.61	1.96	9.49	5.56	1.70	8.92	5.88	1.51	7.04	5.59	1.26	/	/	
-7	14.3	4.59	3.13	14.1	4.89	2.88	13.9	5.19	2.67	13.8	5.55	2.50	13.1	6.02	2.18	12.9	6.22	2.07	12.6	6.29	2.00	8.25	6.18	1.33	/	/	
-5	14.6	4.27	3.47	14.3	4.61	3.13	14.0	4.93	2.86	13.8	5.33	2.61	13.4	5.88	2.28	13.0	5.82	2.22	12.6	5.92	2.13	8.62	5.97	1.45	/	/	
0	15.1	3.49	4.33	14.7	3.91	3.75	14.3	4.27	3.34	13.9	4.80	2.88	14.1	5.33	2.64	13.4	5.14	2.61	12.8	5.42	2.37	9.56	5.54	1.72	/	/	
5	16.8	3.25	5.19	14.6	3.61	4.06	16.1	4.00	4.04	15.6	4.57	3.43	15.9	4.96	3.02	15.3	5.05	3.02	14.5	5.21	2.77	12.7	5.36	2.37	10.7	5.24	2.04
7	17.5	3.16	5.53	15.7	3.12	4.68	16.8	3.79	4.43	16.4	4.25	3.85	16.6	4.71	3.53	16.2	5.05	3.17	16.2	5.53	2.89	14.1	5.34	2.63	11.3	5.13	2.20
10	18.0	3.01	6.02	16.4	3.34	4.96	17.6	3.73	4.74	17.1	4.33	3.96	17.3	4.72	3.67	16.7	5.12	3.26	16.1	5.16	3.11	14.3	5.15	2.79	12.2	4.97	2.46
15	18.9	2.76	6.84	19.3	3.08	6.26	18.9	3.48	5.43	18.3	4.08	4.48	18.5	4.53	4.09	17.8	4.79	3.72	17.5	5.11	3.42	14.7	4.83	3.06	12.5	4.80	2.60
20	16.7	2.08	8.03	16.9	2.38	7.10	16.7	2.69	6.21	17.4	3.40	5.12	16.1	3.77	4.28	14.6	4.06	3.60	15.0	4.32	3.46	13.1	4.39	3.00	/	/	/
25	16.2	1.83	8.86	16.2	2.23	7.26	16.0	2.31	6.94	16.6	2.87	5.81	15.7	3.23	4.87	14.5	3.46	4.20	14.1	3.68	3.82	12.4	4.05	3.07	/	/	/
30	15.6	1.55	10.1	15.5	1.88	8.21	15.4	2.00	7.68	15.9	2.45	6.49	15.3	2.81	5.46	14.4	3.01	4.79	13.2	3.15	4.18	12.7	4.11	3.10	/	/	/
35	16.3	1.50	10.8	16.6	1.84	9.01	16.3	1.94	8.42	16.6	2.42	6.87	15.9	2.79	5.68	15.0	3.00	5.01	13.4	3.07	4.35	/	/	/	/	/	/
40	16.9	1.47	11.5	17.6	1.75	10.1	17.2	1.88	9.15	17.4	2.40	7.24	16.4	2.78	5.91	15.6	2.98	5.22	/	/	/	/	/	/	/	/	/
43	17.2	1.46	11.8	18.0	1.71	10.5	17.6	1.88	9.37	17.7	2.39	7.41	16.7	2.70	6.20	15.9	2.94	5.41	/	/	/	/	/	/	/	/	/

Normal																											
DB	LWT																										
	25			30			35			40			45			50			55			60			65		
	HC	PI	COP	HC	PI	COP	HC	PI	COP	HC	PI	COP	HC	PI	COP	HC	PI	COP	HC	PI	COP	HC	PI	COP			
-25	6.57	3.24	2.03	6.79	3.29	2.06	5.57	3.21	1.73	5.04	3.65	1.38	4.30	3.60	1.19	/	/	/	/	/	/	/	/	/	/	/	
-20	8.42	3.29	2.56	8.50	3.59	2.37	7.07	3.88	1.82	6.59	3.99	1.65	5.74	4.14	1.39	5.15	3.88	1.33	4.89	4.33	1.13	/	/	/	/	/	
-15	9.89	3.37	2.93	9.35	3.52	2.66	8.80	3.79	2.32	8.41	4.14	2.03	7.38	4.26	1.73	6.18	4.21	1.47	5.71	4.40	1.30	5.43	4.77	1.14	/	/	
-10	11.1	3.51	3.15	10.7	3.68	2.90	10.3	3.95	2.61	10.3	4.34	2.37	9.25	4.59	2.01	7.98	4.55	1.75	7.51	4.83	1.55	5.99	4.69	1.28	/	/	
-7	13.9	4.27	3.25	13.5	4.44	3.05	13.3	4.93	2.70	13.1	4.98	2.63	12.9	5.78	2.23	12.4	5.83	2.12	12.5	6.19	2.02	7.69	5.60	1.37	/	/	
-5	12.1	3.21	3.77	11.7	3.49	3.36	11.2	3.65	3.07	11.2	3.98	2.82	10.7	4.44	2.42	10.2	4.83	2.11	9.98	4.50	2.22	7.08	4.76	1.49	/	/	
0	12.0	2.54	4.72	11.5	2.86	4.04	10.9	3.05	3.59	10.7	3.43	3.13	10.8	3.83	2.81	10.1	4.00	2.52	9.77	3.91	2.50	7.66	4.30	1.78	/	/	
5	13.5	2.37	5.71	11.7	2.64	4.41	12.5	2.85	4.38	12.3	3.27	3.76	12.3	3.58	3.44	11.6	3.90	2.97	11.1	3.79	2.93	10.1	4.09	2.47	8.84	4.24	2.08
7	17.0	2.87	5.91	15.2	2.98	5.11	16.0	3.56	4.50	15.7	3.99	3.94	16.0	4.44	3.60	16.0	4.92	3.24	16.0	5.52	2.90	13.2	4.86	2.72	10.2	4.60	2.23
10	14.2	2.14	6.66	12.8	2.36	5.42	13.4	2.59	5.16	13.2	3.01	4.36	13.2	3.33	3.97	12.5	3.66	3.41	12.1	3.71	3.25	11.2	3.88	2.88	9.92	3.93	2.52

# S-Therm Yukon split series



15	15.0	1.97	7.63	15.2	2.20	6.89	14.5	2.43	5.97	14.2	2.84	4.98	14.2	3.19	4.46	13.4	3.41	3.92	13.2	3.67	3.61	11.6	3.64	3.19	10.2	3.81	2.67			
20	13.2	1.46	9.04	13.2	1.67	7.89	12.7	1.84	6.88	13.3	2.32	5.75	12.2	2.59	4.71	10.9	2.83	3.84	11.2	3.04	3.68	10.2	3.24	3.15	/	/	/			
25	12.8	1.29	9.97	12.7	1.57	8.06	12.2	1.59	7.71	12.9	1.78	7.22	12.0	2.24	5.36	10.8	2.43	4.47	10.6	2.60	4.07	9.73	3.01	3.23	/	/	/			
30	12.5	1.11	11.3	12.2	1.35	9.06	11.8	1.40	8.47	12.4	1.55	7.98	11.8	2.06	5.74	10.9	2.15	5.07	10.0	2.29	4.37	10.1	3.12	3.23	/	/	/			
35	13.3	1.10	12.0	13.3	1.35	9.90	12.8	1.41	9.06	13.2	1.79	7.40	12.5	2.07	6.02	11.5	2.16	5.34	10.4	2.27	4.57	/	/	/	/	/	/			
40	14.1	1.10	12.8	14.6	1.31	11.1	13.9	1.40	9.91	14.1	1.80	7.86	13.2	2.10	6.30	12.3	2.19	5.61	/	/	/	/	/	/	/	/	/			
43	14.7	1.10	13.3	15.1	1.29	11.7	14.4	1.41	10.2	14.7	1.81	8.10	13.7	2.06	6.66	12.8	2.19	5.85	/	/	/	/	/	/	/	/	/			
Minimum																														
DB	LWT																													
	25			25			25			25			25			25			25			25			25					
	HC	PI	COP	HC	PI	COP	HC	PI	COP	HC	PI	COP	HC	PI	COP	HC	PI	COP	HC	PI	COP	HC	PI	COP	HC	PI	COP	HC	PI	COP
-25	4.38	2.11	2.08	4.74	2.25	2.11	4.30	2.44	1.76	4.01	2.86	1.40	3.33	2.77	1.20	/	/	/	/	/	/	/	/	/	/	/	/	/	/	/
-20	5.31	2.04	2.60	5.58	2.33	2.40	4.61	2.50	1.85	4.36	2.60	1.68	4.25	3.10	1.37	4.10	3.11	1.32	3.81	3.38	1.13	/	/	/	/	/	/	/	/	/
-15	6.45	2.15	3.00	6.37	2.34	2.72	5.94	2.50	2.38	5.77	2.77	2.08	5.78	3.33	1.73	5.20	3.54	1.47	4.78	3.66	1.30	4.62	4.04	1.15	/	/	/	/	/	/
-10	5.70	1.74	3.27	5.80	1.93	3.01	5.52	2.06	2.68	5.63	2.31	2.43	5.75	2.80	2.05	5.41	3.03	1.79	5.53	3.49	1.58	4.71	3.62	1.30	/	/	/	/	/	/
-7	5.38	1.53	3.52	4.96	1.55	3.21	4.99	1.68	2.97	5.58	1.99	2.80	6.83	2.86	2.38	6.94	3.17	2.19	7.11	3.27	2.17	5.36	3.80	1.41	/	/	/	/	/	/
-5	5.60	1.43	3.93	5.16	1.47	3.50	5.17	1.62	3.20	5.72	1.94	2.94	7.09	2.84	2.50	7.12	3.29	2.17	7.31	3.20	2.28	5.69	3.72	1.53	/	/	/	/	/	/
0	6.04	1.22	4.94	5.72	1.35	4.23	5.49	1.46	3.76	5.93	1.81	3.28	7.66	2.62	2.92	7.58	2.91	2.60	7.52	2.91	2.59	6.32	3.43	1.84	/	/	/	/	/	/
5	6.80	1.13	5.99	5.78	1.25	4.64	6.27	1.36	4.60	6.77	1.71	3.95	8.74	2.43	3.59	8.70	2.82	3.09	9.11	3.00	3.04	8.65	3.36	2.57	7.55	3.51	2.15			
7	6.96	1.08	6.43	5.67	1.05	5.38	6.43	1.27	5.08	6.97	1.56	4.46	9.02	2.26	3.99	9.01	2.58	3.49	9.96	3.13	3.19	9.46	3.29	2.87	7.87	3.41	2.31			
10	7.35	1.05	7.01	6.51	1.14	5.70	6.91	1.27	5.44	7.44	1.62	4.59	9.58	2.31	4.15	9.56	2.66	3.59	10.2	2.99	3.40	9.78	3.24	3.02	8.66	3.38	2.56			
15	7.40	0.93	7.99	7.57	1.05	7.22	7.39	1.18	6.26	8.45	1.62	5.22	10.3	2.21	4.64	11.0	2.67	4.12	11.4	3.02	3.75	10.5	3.16	3.32	9.17	3.37	2.72			
20	6.67	0.70	9.46	6.76	0.82	8.27	6.65	0.92	7.21	8.17	1.36	6.02	9.04	1.85	4.89	9.12	2.26	4.03	9.82	2.57	3.83	9.42	2.87	3.28	/	/	/	/	/	/
25	6.62	0.63	10.4	6.64	0.79	8.45	6.54	0.81	8.07	7.99	1.17	6.82	8.98	1.61	5.57	9.20	1.96	4.69	9.38	2.22	4.23	9.04	2.69	3.36	/	/	/	/	/	/
30	7.29	0.62	11.8	7.58	0.80	9.48	8.38	0.96	8.70	8.91	1.21	7.36	8.88	1.47	6.03	9.25	1.74	5.33	8.95	1.95	4.59	9.05	2.66	3.40	/	/	/	/	/	/
35	7.75	0.61	12.7	8.28	0.79	10.5	9.05	0.94	9.60	9.48	1.21	7.85	9.34	1.48	6.33	9.77	1.74	5.61	9.23	1.92	4.81	/	/	/	/	/	/	/	/	/
40	8.22	0.61	13.6	9.00	0.76	11.8	9.75	0.93	10.5	9.89	1.19	8.34	9.68	1.46	6.62	10.3	1.75	5.90	/	/	/	/	/	/	/	/	/	/	/	/
43	8.64	0.61	14.1	9.45	0.76	12.4	10.2	0.94	10.8	10.4	1.21	8.59	10.2	1.46	7.00	10.7	1.75	6.15	/	/	/	/	/	/	/	/	/	/	/	/

Abbreviations:

LWT: Leaving water temperature (°C)

DB: Dry-bulb temperature for Outdoor air temperature (°C)

HC: Total heating capacity (kW)

PI: Power input (kW)

## 5.2 Cooling Capacity Tables (Test standard: EN14511)

Table 2-5.8: MSH-40EB cooling capacity

Maximum																
DB	LWT															
	5			10			15			20			25			
	CC	PI	EER	CC	PI	EER	CC	PI	EER	CC	PI	EER	CC	PI	EER	
-5	/	/	/	/	/	/	4.76	0.46	10.30	5.47	0.55	10.01	6.09	0.48	12.66	
0	/	/	/	/	/	/	4.54	0.57	8.03	5.25	0.65	8.08	5.87	0.55	10.70	
5	/	/	/	/	/	/	4.04	0.67	6.07	4.75	0.75	6.34	5.37	0.65	8.28	
10	/	/	/	/	/	/	6.06	1.06	5.71	6.44	1.01	6.40	7.11	0.85	8.37	
15	/	/	/	5.05	0.86	5.91	8.09	1.46	5.55	8.14	1.26	6.44	8.85	1.05	8.43	
20	4.72	1.04	4.53	6.01	1.35	4.47	8.16	1.49	5.47	8.33	1.30	6.42	8.98	1.10	8.15	
25	5.87	1.30	4.51	6.97	1.84	3.80	8.23	1.53	5.39	8.52	1.33	6.40	9.12	1.15	7.90	
30	5.84	1.55	3.78	6.80	1.85	3.67	7.77	1.65	4.72	8.19	1.46	5.63	8.77	1.30	6.75	
35	5.80	1.79	3.24	6.64	1.87	3.55	7.31	1.76	4.15	7.87	1.58	4.98	8.43	1.44	5.84	
40	3.80	1.51	2.52	5.08	1.81	2.81	5.91	1.73	3.41	6.63	1.68	3.95	7.88	1.64	4.80	
43	2.58	1.15	2.24	3.80	1.52	2.51	5.08	1.56	3.26	5.88	1.57	3.74	7.55	1.59	4.73	
Normal																
DB	LWT															
	5			10			15			20			25			
	CC	PI	EER	CC	PI	EER	CC	PI	EER	CC	PI	EER	CC	PI	EER	
-5	/	/	/	/	/	/	3.83	0.33	11.74	4.45	0.37	11.92	4.95	0.35	14.10	
0	/	/	/	/	/	/	3.66	0.39	9.35	4.28	0.44	9.81	4.78	0.36	13.31	
5	/	/	/	/	/	/	3.23	0.48	6.68	3.81	0.52	7.29	4.36	0.45	9.77	

10	/	/	/	/	/	/	4.87	0.77	6.29	5.19	0.70	7.37	5.79	0.59	9.89
15	/	/	/	3.79	0.61	6.25	6.79	1.15	5.89	7.00	0.99	7.06	7.44	0.80	9.29
20	3.68	0.77	4.76	4.86	1.01	4.80	6.80	1.16	5.88	7.17	1.03	6.94	7.82	0.87	8.98
25	4.65	0.97	4.78	5.72	1.40	4.09	6.96	1.21	5.74	7.44	1.07	6.98	8.05	0.91	8.85
30	4.69	1.17	4.02	5.67	1.45	3.92	6.67	1.32	5.06	7.25	1.20	6.05	7.85	1.06	7.44
35	4.51	1.32	3.40	5.45	1.43	3.82	6.02	1.35	4.47	6.87	1.28	5.36	7.69	1.20	6.39
40	3.10	1.15	2.70	4.30	1.42	3.03	5.15	1.40	3.68	5.95	1.37	4.34	7.15	1.32	5.41
43	2.12	0.91	2.33	2.99	1.15	2.59	4.04	1.18	3.43	5.04	1.25	4.04	5.97	1.15	5.18
<b>Minimum</b>															
DB	<b>LWT (°C)</b>														
	5			10			15			20			25		
	CC	PI	EER	CC	PI	EER	CC	PI	EER	CC	PI	EER	CC	PI	EER
-5	/	/	/	/	/	/	2.48	0.20	12.60	2.87	0.23	12.38	3.21	0.20	15.83
0	/	/	/	/	/	/	2.37	0.24	9.92	2.77	0.27	10.09	3.11	0.23	13.40
5	/	/	/	/	/	/	1.74	0.24	7.35	2.06	0.27	7.76	2.35	0.23	10.17
10	/	/	/	/	/	/	2.70	0.39	6.99	2.90	0.37	7.91	3.21	0.31	10.39
15	/	/	/	2.32	0.35	6.64	3.64	0.58	6.29	3.50	0.45	7.80	4.25	0.41	10.32
20	1.86	0.38	4.95	2.13	0.43	5.00	3.38	0.54	6.23	3.95	0.54	7.32	4.44	0.47	9.50
25	2.23	0.46	4.89	2.37	0.55	4.29	3.29	0.54	6.04	3.92	0.53	7.33	4.38	0.47	9.28
30	2.23	0.54	4.10	2.33	0.57	4.11	3.12	0.59	5.30	3.79	0.59	6.38	4.23	0.55	7.72
35	2.05	0.59	3.50	2.53	0.63	4.00	3.01	0.63	4.79	3.66	0.63	5.81	4.23	0.62	6.84
40	1.40	0.52	2.69	2.00	0.54	3.12	2.52	0.66	3.82	3.18	0.71	4.50	4.07	0.74	5.51
43	0.73	0.31	2.38	1.43	0.53	2.68	2.11	0.59	3.57	2.57	0.62	4.17	3.80	0.71	5.38

Abbreviations:

LWT: Leaving water temperature (°C)

DB: Dry-bulb temperature for Outdoor air temperature (°C)

CC: Total cooling capacity (kW)

PI: Power input (kW)

Table 2-5.9: MSH-60EB cooling capacity

<b>Maximum</b>															
DB	<b>LWT</b>														
	5			10			15			20			25		
	CC	PI	EER	CC	PI	EER	CC	PI	EER	CC	PI	EER	CC	PI	EER
-5	/	/	/	/	/	/	5.27	0.59	8.93	6.38	0.55	11.53	6.77	0.64	10.62
0	/	/	/	/	/	/	5.05	0.69	7.28	6.16	0.66	9.39	6.55	0.74	8.85
5	/	/	/	/	/	/	4.55	0.79	5.74	5.66	0.76	7.48	6.05	0.84	7.20
10	/	/	/	/	/	/	6.32	1.13	5.61	6.90	1.01	6.83	7.45	0.95	7.88
15	/	/	/	5.89	1.10	5.33	8.09	1.46	5.55	8.14	1.26	6.44	8.85	1.05	8.43
20	5.41	1.38	3.93	6.63	1.43	4.62	8.16	1.49	5.47	8.33	1.30	6.42	8.98	1.10	8.15
25	7.16	1.80	3.98	7.37	1.77	4.17	8.23	1.53	5.39	8.52	1.33	6.40	9.12	1.15	7.90
30	6.50	1.85	3.51	7.29	1.90	3.84	7.77	1.65	4.72	8.19	1.46	5.63	8.77	1.30	6.75
35	5.84	1.90	3.07	7.22	2.03	3.55	7.31	1.76	4.15	7.87	1.58	4.98	8.43	1.44	5.84
40	3.80	1.51	2.52	5.08	1.81	2.81	5.91	1.73	3.41	6.63	1.68	3.95	7.88	1.64	4.80
43	2.58	1.15	2.24	3.80	1.52	2.51	5.08	1.56	3.26	5.88	1.57	3.74	7.55	1.59	4.73
<b>Normal</b>															
DB	<b>LWT</b>														
	5			10			15			20			25		
	CC	PI	EER	CC	PI	EER	CC	PI	EER	CC	PI	EER	CC	PI	EER
-5	/	/	/	/	/	/	4.24	0.42	10.18	5.19	0.38	13.72	5.50	0.42	12.96
0	/	/	/	/	/	/	4.07	0.48	8.48	5.02	0.44	11.39	5.33	0.48	11.01
5	/	/	/	/	/	/	3.64	0.58	6.31	4.54	0.53	8.61	4.91	0.58	8.49
10	/	/	/	/	/	/	5.08	0.82	6.18	5.55	0.71	7.86	6.06	0.65	9.31

# S-Therm Yukon split series



15	/	/	/	4.42	0.78	5.65	6.79	1.15	5.89	7.00	0.99	7.06	7.44	0.80	9.29
20	4.22	1.02	4.14	5.36	1.08	4.96	6.80	1.16	5.88	7.17	1.03	6.94	7.82	0.87	8.98
25	5.67	1.35	4.21	6.05	1.35	4.49	6.96	1.21	5.74	7.44	1.07	6.98	8.05	0.91	8.85
30	5.23	1.40	3.74	6.08	1.48	4.10	6.67	1.32	5.06	7.25	1.20	6.05	7.85	1.06	7.44
35	4.54	1.41	3.22	5.93	1.55	3.83	6.02	1.35	4.47	6.87	1.28	5.36	7.69	1.20	6.39
40	3.10	1.15	2.70	4.30	1.42	3.03	5.15	1.40	3.68	5.95	1.37	4.34	7.15	1.32	5.41
43	2.12	0.91	2.33	2.99	1.15	2.59	4.04	1.18	3.43	5.04	1.25	4.04	5.97	1.15	5.18
Minimum															
DB	LWT														
	5			10			15			20			25		
	CC	PI	EER	CC	PI	EER	CC	PI	EER	CC	PI	EER	CC	PI	EER
-5	/	/	/	/	/	/	2.75	0.25	10.92	3.35	0.23	14.26	3.57	0.27	13.17
0	/	/	/	/	/	/	2.64	0.29	9.00	3.25	0.28	11.72	3.47	0.31	11.08
5	/	/	/	/	/	/	1.96	0.28	6.95	2.46	0.27	9.16	2.64	0.30	8.84
10	/	/	/	/	/	/	2.81	0.41	6.87	3.10	0.37	8.44	3.36	0.34	9.78
15	/	/	/	2.71	0.45	5.99	3.64	0.58	6.29	3.50	0.45	7.80	4.25	0.41	10.32
20	2.13	0.50	4.30	2.35	0.45	5.17	3.38	0.54	6.23	3.95	0.54	7.32	4.44	0.47	9.50
25	2.72	0.63	4.31	2.50	0.53	4.72	3.29	0.54	6.04	3.92	0.53	7.33	4.38	0.47	9.28
30	2.48	0.65	3.81	2.49	0.58	4.30	3.12	0.59	5.30	3.79	0.59	6.38	4.23	0.55	7.72
35	2.07	0.62	3.31	2.75	0.69	4.00	3.01	0.63	4.79	3.66	0.63	5.81	4.23	0.62	6.84
40	1.40	0.52	2.69	2.01	0.64	3.12	2.52	0.66	3.82	3.18	0.71	4.50	4.07	0.74	5.51
43	0.73	0.31	2.38	1.43	0.53	2.68	2.11	0.59	3.57	2.57	0.62	4.17	3.80	0.71	5.38

Abbreviations:

LWT: Leaving water temperature (°C)

DB: Dry-bulb temperature for Outdoor air temperature (°C)

CC: Total cooling capacity (kW)

PI: Power input (kW)

Table 2-5.10: MSH-80EB cooling capacity

Maximum															
DB	LWT														
	5			10			15			20			25		
	CC	PI	EER	CC	PI	EER	CC	PI	EER	CC	PI	EER	CC	PI	EER
-5	/	/	/	/	/	/	6.39	0.63	10.07	8.21	0.76	10.82	8.74	0.71	12.31
0	/	/	/	/	/	/	6.17	0.71	8.69	7.26	0.74	9.76	7.76	0.70	11.05
5	/	/	/	/	/	/	5.96	0.82	7.30	6.30	0.72	8.69	6.78	0.69	9.78
10	/	/	/	/	/	/	6.29	0.74	8.54	7.91	0.84	9.45	8.30	0.79	10.53
15	/	/	/	5.97	0.87	6.84	7.33	0.99	7.38	9.11	1.15	7.94	9.73	1.12	8.67
20	5.68	1.15	4.96	7.06	1.29	5.46	8.38	1.35	6.22	10.31	1.60	6.43	11.15	1.64	6.81
25	6.47	1.48	4.36	7.82	1.63	4.81	9.26	1.68	5.52	11.25	1.90	5.92	12.76	2.02	6.33
30	7.27	1.89	3.85	8.57	2.01	4.25	10.15	2.06	4.93	12.20	2.20	5.54	14.36	2.40	6.00
35	7.39	2.25	3.28	8.77	2.31	3.80	10.21	2.31	4.43	11.74	2.40	4.89	13.59	2.50	5.42
40	6.61	2.52	2.62	7.42	2.37	3.14	8.88	2.53	3.51	10.23	2.51	4.07	12.27	2.83	4.34
43	5.09	2.28	2.23	5.64	2.19	2.58	6.73	2.13	3.16	8.15	2.17	3.75	10.04	2.49	4.03
Normal															
DB	LWT														
	5			10			15			20			25		
	CC	PI	EER	CC	PI	EER	CC	PI	EER	CC	PI	EER	CC	PI	EER
-5	/	/	/	/	/	/	5.14	0.45	11.38	6.68	0.53	12.50	7.10	0.51	14.03
0	/	/	/	/	/	/	4.98	0.50	9.94	5.91	0.52	11.31	6.31	0.49	12.86
5	/	/	/	/	/	/	4.77	0.60	7.96	5.05	0.52	9.69	5.50	0.51	10.76

10	/	/	/	/	/	/	5.05	0.54	9.32	6.37	0.60	10.55	6.75	0.58	11.60
15	/	/	/	4.48	0.62	7.24	6.16	0.79	7.83	7.83	0.90	8.70	8.17	0.86	9.55
20	4.43	0.85	5.21	5.71	0.97	5.86	6.99	1.04	6.69	8.87	1.28	6.95	9.71	1.29	7.50
25	5.13	1.11	4.61	6.42	1.24	5.17	7.84	1.33	5.87	9.82	1.52	6.46	11.26	1.59	7.09
30	5.84	1.42	4.10	7.14	1.57	4.54	8.71	1.65	5.28	10.80	1.82	5.94	12.86	1.95	6.61
35	5.75	1.67	3.45	7.20	1.76	4.09	8.42	1.76	4.77	10.25	1.95	5.26	12.39	2.09	5.94
40	5.40	1.92	2.81	6.27	1.86	3.38	7.73	2.04	3.79	9.18	2.06	4.47	11.14	2.28	4.89
43	4.18	1.80	2.32	4.44	1.66	2.67	5.36	1.61	3.32	6.98	1.72	4.06	7.94	1.80	4.41

**Minimum**

DB	LWT														
	5			10			15			20			25		
	CC	PI	EER	CC	PI	EER	CC	PI	EER	CC	PI	EER	CC	PI	EER
-5	/	/	/	/	/	/	3.33	0.28	11.86	4.31	0.33	12.89	4.60	0.31	14.71
0	/	/	/	/	/	/	3.23	0.31	10.38	3.83	0.32	11.79	4.11	0.31	13.34
5	/	/	/	/	/	/	2.57	0.30	8.55	2.74	0.27	10.29	2.96	0.26	11.57
10	/	/	/	/	/	/	2.80	0.28	10.11	3.56	0.31	11.31	3.75	0.30	12.59
15	/	/	/	2.75	0.36	7.69	3.30	0.39	8.37	3.92	0.41	9.62	4.67	0.44	10.61
20	2.24	0.41	5.42	2.50	0.41	6.12	3.47	0.49	7.09	4.88	0.67	7.33	5.51	0.69	7.93
25	2.46	0.52	4.73	2.66	0.49	5.43	3.71	0.60	6.18	5.18	0.76	6.78	6.12	0.82	7.44
30	2.78	0.66	4.19	2.93	0.62	4.76	4.08	0.74	5.53	5.64	0.90	6.28	6.92	1.01	6.86
35	2.62	0.74	3.54	3.34	0.78	4.28	4.21	0.82	5.12	5.46	0.96	5.70	6.82	1.07	6.36
40	2.44	0.87	2.80	2.94	0.84	3.48	3.79	0.97	3.93	4.91	1.06	4.64	6.34	1.28	4.97
43	1.43	0.60	2.37	2.12	0.77	2.76	2.80	0.81	3.46	3.55	0.85	4.18	5.06	1.11	4.58

Abbreviations:

LWT: Leaving water temperature (°C)

DB: Dry-bulb temperature for Outdoor air temperature (°C)

CC: Total cooling capacity (kW)

PI: Power input (kW)

Table 2-5.11: MSH-100EB cooling capacity

Maximum															
DB	LWT														
	5			10			15			20			25		
	CC	PI	EER	CC	PI	EER	CC	PI	EER	CC	PI	EER	CC	PI	EER
-5	/	/	/	/	/	/	6.83	0.69	9.92	8.79	0.82	10.66	9.35	0.77	12.13
0	/	/	/	/	/	/	6.61	0.77	8.56	7.76	0.81	9.61	8.30	0.76	10.88
5	/	/	/	/	/	/	6.38	0.89	7.19	6.74	0.79	8.56	7.25	0.75	9.63
10	/	/	/	/	/	/	6.55	0.75	8.73	8.17	0.80	10.18	8.80	0.86	10.22
15	/	/	/	6.30	1.07	5.89	7.61	1.03	7.35	9.48	1.13	8.38	10.64	1.20	8.84
20	6.20	1.28	4.86	7.19	1.39	5.17	8.67	1.45	5.97	10.79	1.64	6.57	12.49	1.68	7.45
25	7.13	1.68	4.24	8.26	1.81	4.56	9.87	1.88	5.24	12.00	2.07	5.79	13.93	2.17	6.42
30	8.06	2.17	3.71	9.34	2.31	4.05	11.08	2.40	4.62	13.21	2.57	5.14	15.37	2.79	5.51
35	8.13	2.48	3.12	9.48	2.43	3.72	11.03	2.62	4.21	12.70	2.68	4.73	14.51	2.87	5.06
40	6.61	2.52	2.62	7.42	2.37	3.14	8.88	2.53	3.51	10.23	2.51	4.07	12.27	2.83	4.34
43	5.09	2.28	2.23	5.64	2.19	2.58	6.73	2.13	3.16	8.15	2.17	3.75	10.04	2.49	4.03
Normal															
DB	LWT														
	5			10			15			20			25		
	CC	PI	EER	CC	PI	EER	CC	PI	EER	CC	PI	EER	CC	PI	EER
-5	/	/	/	/	/	/	5.50	0.49	11.21	7.15	0.58	12.31	7.59	0.55	13.82
0	/	/	/	/	/	/	5.33	0.54	9.79	6.33	0.57	11.14	6.75	0.53	12.66

# S-Therm Yukon split series



5	/	/	/	/	/	/	5.11	0.65	7.84	5.41	0.57	9.54	5.88	0.56	10.60
10	/	/	/	/	/	/	5.26	0.55	9.53	6.58	0.58	11.37	7.16	0.64	11.26
15	/	/	/	4.73	0.76	6.24	6.39	0.82	7.80	8.15	0.89	9.18	8.94	0.92	9.74
20	4.83	0.95	5.11	5.82	1.05	5.55	7.23	1.13	6.42	9.29	1.31	7.10	10.87	1.32	8.21
25	5.65	1.26	4.49	6.78	1.38	4.91	8.35	1.50	5.58	10.47	1.66	6.32	12.30	1.71	7.18
30	6.48	1.64	3.95	7.78	1.80	4.32	9.51	1.92	4.95	11.69	2.12	5.51	13.76	2.26	6.08
35	6.31	1.93	3.28	7.78	1.94	4.01	9.09	2.01	4.53	11.08	2.18	5.09	13.23	2.39	5.54
40	5.40	1.92	2.81	6.27	1.86	3.38	7.73	2.04	3.79	9.18	2.06	4.47	11.14	2.28	4.89
43	4.18	1.80	2.32	4.44	1.66	2.67	5.36	1.61	3.32	6.98	1.72	4.06	7.94	1.80	4.41
Minimum															
DB	LWT														
	5			10			15			20			25		
	CC	PI	EER	CC	PI	EER	CC	PI	EER	CC	PI	EER	CC	PI	EER
-5	/	/	/	/	/	/	3.56	0.30	11.68	4.61	0.36	12.69	4.93	0.34	14.49
0	/	/	/	/	/	/	3.46	0.34	10.23	4.09	0.35	11.61	4.39	0.33	13.14
5	/	/	/	/	/	/	2.75	0.33	8.42	2.93	0.29	10.13	3.17	0.28	11.40
10	/	/	/	/	/	/	2.92	0.28	10.33	3.67	0.30	12.18	3.97	0.33	12.22
15	/	/	/	2.90	0.44	6.62	3.42	0.41	8.33	4.08	0.40	10.14	5.11	0.47	10.81
20	2.44	0.46	5.31	2.55	0.44	5.79	3.59	0.53	6.81	5.11	0.68	7.49	6.17	0.71	8.68
25	2.71	0.59	4.60	2.81	0.55	5.15	3.95	0.67	5.88	5.52	0.83	6.64	6.69	0.89	7.54
30	3.08	0.76	4.03	3.19	0.70	4.53	4.45	0.86	5.19	6.10	1.05	5.82	7.41	1.18	6.30
35	2.88	0.85	3.37	3.61	0.86	4.19	4.55	0.94	4.86	5.90	1.07	5.52	7.28	1.23	5.93
40	2.44	0.87	2.80	2.94	0.84	3.48	3.79	0.97	3.93	4.91	1.06	4.64	6.34	1.28	4.97
43	1.43	0.60	2.37	2.12	0.77	2.76	2.80	0.81	3.46	3.55	0.85	4.18	5.06	1.11	4.58

Abbreviations:

LWT: Leaving water temperature (°C)

DB: Dry-bulb temperature for Outdoor air temperature (°C)

CC: Total cooling capacity (kW)

PI: Power input (kW)

Table 2-5.12: MSH-120EB; MSH-120EB-3 cooling capacity

Maximum															
DB	LWT														
	5			10			15			20			25		
	CC	PI	EER	CC	PI	EER	CC	PI	EER	CC	PI	EER	CC	PI	EER
-5	/	/	/	/	/	/	9.55	1.27	7.50	10.39	1.41	7.37	11.39	1.36	8.35
0	/	/	/	/	/	/	9.33	1.57	5.93	10.90	1.49	7.32	11.89	1.50	7.92
5	/	/	/	/	/	/	9.12	1.71	5.32	11.41	1.57	7.27	12.38	1.64	7.57
10	/	/	/	/	/	/	10.81	2.05	5.27	13.14	1.92	6.85	14.18	1.94	7.32
15	/	/	/	10.51	2.32	4.53	12.50	2.33	5.36	14.87	2.27	6.56	15.98	2.24	7.14
20	7.78	2.03	3.83	12.15	2.96	4.10	14.16	3.12	4.54	15.93	3.14	5.08	16.53	2.84	5.82
25	10.10	3.00	3.37	13.80	3.61	3.82	15.82	3.91	4.04	17.00	4.01	4.24	17.07	3.44	4.96
30	9.99	3.58	2.79	13.43	4.13	3.25	15.18	4.17	3.64	16.17	4.15	3.90	16.11	3.74	4.31
35	9.89	4.52	2.19	13.07	4.90	2.67	14.53	4.56	3.19	15.34	4.38	3.51	15.26	4.00	3.81
40	8.11	4.53	1.79	9.87	4.33	2.28	10.67	3.92	2.72	12.19	4.05	3.01	13.23	3.77	3.51
43	5.20	3.72	1.40	6.11	3.26	1.87	7.33	3.02	2.43	8.53	3.19	2.67	10.68	3.26	3.27
Normal															
DB	LWT														
	5			10			15			20			25		
	CC	PI	EER	CC	PI	EER	CC	PI	EER	CC	PI	EER	CC	PI	EER
-5	/	/	/	/	/	/	7.69	0.91	8.47	8.46	0.99	8.51	9.25	0.97	9.52

0	/	/	/	/	/	/	7.53	1.11	6.78	8.89	1.05	8.48	9.67	1.05	9.22
5	/	/	/	/	/	/	7.30	1.26	5.80	9.16	1.13	8.10	10.05	1.21	8.32
10	/	/	/	/	/	/	8.68	1.51	5.75	10.57	1.38	7.65	11.54	1.43	8.07
15	/	/	/	7.88	1.62	4.86	10.50	1.80	5.82	12.78	1.74	7.36	13.43	1.67	8.05
20	6.07	1.51	4.02	9.83	2.20	4.46	11.81	2.36	4.99	13.71	2.44	5.61	14.39	2.19	6.56
25	8.00	2.24	3.56	11.33	2.71	4.17	13.39	3.04	4.41	14.84	3.14	4.73	15.07	2.65	5.68
30	8.04	2.71	2.97	11.19	3.18	3.52	13.03	3.27	3.99	14.31	3.34	4.28	14.43	2.97	4.86
35	7.68	3.34	2.30	10.73	3.69	2.91	11.97	3.41	3.51	13.39	3.47	3.86	13.91	3.26	4.27
40	6.62	3.45	1.92	8.35	3.35	2.49	9.28	3.09	3.00	10.94	3.24	3.38	12.00	2.97	4.05
43	4.27	2.93	1.45	4.80	2.44	1.97	5.83	2.23	2.61	7.30	2.47	2.96	8.44	2.30	3.66
<b>Minimum</b>															
DB	LWT														
	5			10			15			20			25		
	CC	PI	EER	CC	PI	EER	CC	PI	EER	CC	PI	EER	CC	PI	EER
-5	/	/	/	/	/	/	4.98	0.56	8.83	5.46	0.62	8.78	6.00	0.60	9.98
0	/	/	/	/	/	/	4.88	0.69	7.09	5.75	0.65	8.84	6.29	0.66	9.56
5	/	/	/	/	/	/	3.93	0.63	6.23	4.96	0.58	8.61	5.41	0.60	8.95
10	/	/	/	/	/	/	4.81	0.77	6.24	5.91	0.72	8.20	6.40	0.73	8.75
15	/	/	/	4.83	0.94	5.16	5.63	0.91	6.22	6.39	0.79	8.11	7.67	0.86	8.92
20	3.07	0.73	4.18	4.30	0.92	4.65	5.86	1.11	5.29	7.55	1.28	5.92	8.16	1.18	6.93
25	3.84	1.05	3.65	4.69	1.07	4.38	6.33	1.36	4.64	7.82	1.58	4.96	8.19	1.38	5.95
30	3.82	1.26	3.03	4.59	1.25	3.68	6.10	1.46	4.17	7.47	1.65	4.51	7.77	1.54	5.04
35	3.50	1.48	2.36	4.98	1.64	3.04	5.99	1.59	3.76	7.13	1.71	4.18	7.66	1.68	4.56
40	2.99	1.56	1.91	3.91	1.53	2.56	4.55	1.46	3.11	5.85	1.67	3.50	6.83	1.66	4.12
43	1.46	0.98	1.48	2.30	1.13	2.03	3.05	1.12	2.72	3.72	1.22	3.04	5.38	1.42	3.80

Abbreviations:

LWT: Leaving water temperature (°C)

DB: Dry-bulb temperature for Outdoor air temperature (°C)

CC: Total cooling capacity (kW)

PI: Power input (kW)

Table 2-5.13MSH-140EB; MSH-140EB-3 cooling capacity

<b>Maximum</b>															
DB	LWT														
	5			10			15			20			25		
	CC	PI	EER	CC	PI	EER	CC	PI	EER	CC	PI	EER	CC	PI	EER
-5	/	/	/	/	/	/	10.0	1.32	7.57	10.9	1.47	7.44	12.0	1.42	8.43
0	/	/	/	/	/	/	9.80	1.67	5.87	11.4	1.58	7.24	12.5	1.59	7.84
5	/	/	/	/	/	/	9.57	1.76	5.44	12.0	1.61	7.43	13.0	1.68	7.73
10	/	/	/	/	/	/	11.3	2.18	5.21	13.1	1.92	6.85	14.2	1.94	7.32
15	/	/	/	11.0	2.32	4.60	13.1	2.32	5.45	15.5	2.32	6.67	16.4	2.32	7.26
20	8.17	2.17	3.77	12.8	3.16	4.04	14.9	3.33	4.47	15.9	3.14	5.08	16.5	2.84	5.82
25	10.6	3.19	3.32	14.5	3.84	3.77	16.6	4.16	3.99	17.0	4.01	4.24	17.1	3.44	4.96
30	10.5	3.96	2.65	14.1	4.53	3.11	15.9	4.56	3.49	16.2	4.18	3.87	16.1	3.74	4.31
35	10.4	4.81	2.16	13.7	5.32	2.58	15.3	4.88	3.13	15.3	4.44	3.45	15.3	4.12	3.71
40	8.11	4.53	1.79	9.87	4.33	2.28	10.7	3.92	2.72	12.2	4.05	3.01	13.2	3.77	3.51
43	5.20	3.72	1.40	6.11	3.26	1.87	7.33	3.02	2.43	8.53	3.19	2.67	10.7	3.26	3.27
<b>Normal</b>															
DB	LWT														
	5			10			15			20			25		
	CC	PI	EER	CC	PI	EER	CC	PI	EER	CC	PI	EER	CC	PI	EER

# S-Therm Yukon split series



-5	/	/	/	/	/	/	8.07	0.94	8.56	8.88	1.03	8.60	9.72	1.01	9.61
0	/	/	/	/	/	/	7.90	1.18	6.71	9.33	1.11	8.39	10.2	1.11	9.13
5	/	/	/	/	/	/	7.67	1.29	5.93	9.61	1.16	8.28	10.6	1.24	8.50
10	/	/	/	/	/	/	9.12	1.60	5.69	10.6	1.38	7.65	11.5	1.43	8.07
15	/	/	/	8.24	1.67	4.94	11.0	1.85	5.92	13.4	1.79	7.48	13.8	1.68	8.19
20	6.37	1.61	3.96	10.3	2.35	4.40	12.4	2.52	4.92	13.7	2.44	5.61	14.4	2.19	6.56
25	8.40	2.39	3.52	11.9	2.89	4.12	14.1	3.23	4.35	14.8	3.14	4.73	15.1	2.65	5.68
30	8.44	2.99	2.82	11.8	3.49	3.37	13.7	3.57	3.83	14.3	3.37	4.25	14.4	2.97	4.86
35	8.07	3.56	2.27	11.3	4.00	2.81	12.6	3.65	3.45	13.4	3.52	3.80	13.9	3.35	4.15
40	6.62	3.45	1.92	8.35	3.35	2.49	9.28	3.09	3.00	10.9	3.24	3.38	12.0	2.97	4.05
43	4.27	2.93	1.45	4.80	2.44	1.97	5.83	2.23	2.61	7.30	2.47	2.96	8.44	2.30	3.66

### Minimum

DB	LWT														
	5			10			15			20			25		
	CC	PI	EER	CC	PI	EER	CC	PI	EER	CC	PI	EER	CC	PI	EER
-5	/	/	/	/	/	/	5.22	0.59	8.92	5.73	0.65	8.86	6.30	0.63	10.08
0	/	/	/	/	/	/	5.13	0.73	7.01	6.04	0.69	8.75	6.61	0.70	9.47
5	/	/	/	/	/	/	4.12	0.65	6.37	5.21	0.59	8.80	5.68	0.62	9.15
10	/	/	/	/	/	/	5.06	0.82	6.16	5.91	0.72	8.20	6.40	0.73	8.75
15	/	/	/	5.05	0.96	5.24	5.88	0.93	6.32	6.68	0.81	8.25	7.86	0.87	9.07
20	3.22	0.78	4.12	4.52	0.99	4.58	6.16	1.18	5.21	7.55	1.28	5.92	8.16	1.18	6.93
25	4.03	1.12	3.60	4.93	1.14	4.32	6.65	1.45	4.58	7.82	1.58	4.96	8.19	1.38	5.95
30	4.01	1.39	2.88	4.82	1.37	3.53	6.41	1.60	4.01	7.47	1.67	4.48	7.77	1.54	5.04
35	3.67	1.58	2.33	5.23	1.78	2.94	6.29	1.70	3.69	7.13	1.73	4.11	7.66	1.73	4.44
40	2.99	1.56	1.91	3.91	1.53	2.56	4.55	1.46	3.11	5.85	1.67	3.50	6.83	1.66	4.12
43	1.46	0.98	1.48	2.30	1.13	2.03	3.05	1.12	2.72	3.72	1.22	3.04	5.38	1.42	3.80

Abbreviations:

LWT: Leaving water temperature (°C)

DB: Dry-bulb temperature for Outdoor air temperature (°C)

CC: Total cooling capacity (kW)

PI: Power input (kW)

Table 2-5.14 MSH-160EB; MSH-160EB-3 cooling capacity

Maximum															
DB	LWT														
	5			10			15			20			25		
	CC	PI	EER	CC	PI	EER	CC	PI	EER	CC	PI	EER	CC	PI	EER
-5	/	/	/	/	/	/	10.0	1.32	7.57	10.9	1.47	7.44	12.0	1.42	8.43
0	/	/	/	/	/	/	9.80	1.67	5.87	11.4	1.58	7.24	12.5	1.59	7.84
5	/	/	/	/	/	/	9.57	1.76	5.44	12.0	1.61	7.43	13.0	1.68	7.73
10	/	/	/	/	/	/	11.3	2.18	5.21	13.1	1.92	6.85	14.2	1.94	7.32
15	/	/	/	11.4	2.43	4.67	13.5	2.44	5.53	16.1	2.37	6.77	17.0	2.30	7.37
20	8.99	2.43	3.70	14.0	3.55	3.96	15.8	3.56	4.42	16.9	3.36	5.03	17.5	3.04	5.76
25	11.7	3.59	3.25	15.9	4.32	3.69	17.4	4.47	3.90	17.9	4.31	4.14	17.9	3.70	4.84
30	11.5	4.46	2.59	15.5	5.11	3.04	17.2	5.05	3.41	17.1	4.66	3.68	16.9	4.02	4.21
35	11.4	5.42	2.11	15.1	6.00	2.52	16.5	5.60	2.94	16.3	4.96	3.27	16.2	4.47	3.62
40	8.92	5.11	1.75	10.9	4.89	2.22	11.7	4.42	2.65	13.4	4.69	2.86	14.6	4.36	3.34
43	5.98	4.50	1.33	7.33	4.12	1.78	9.01	3.91	2.31	10.5	4.13	2.54	12.0	3.85	3.11
Normal															
DB	LWT														
	5			10			15			20			25		
	CC	PI	EER	CC	PI	EER	CC	PI	EER	CC	PI	EER	CC	PI	EER
-5	/	/	/	/	/	/	8.07	0.94	8.56	8.88	1.03	8.60	9.72	1.01	9.61
0	/	/	/	/	/	/	7.90	1.18	6.71	9.33	1.11	8.39	10.2	1.11	9.13
5	/	/	/	/	/	/	7.67	1.29	5.93	9.61	1.16	8.28	10.6	1.24	8.50
10	/	/	/	/	/	/	9.12	1.60	5.69	10.6	1.38	7.65	11.5	1.43	8.07
15	/	/	/	8.52	1.70	5.02	11.4	1.89	6.01	13.8	1.82	7.59	14.2	1.71	8.31
20	7.01	1.80	3.88	11.4	2.63	4.31	13.1	2.70	4.87	14.5	2.62	5.56	15.3	2.35	6.49
25	9.24	2.69	3.43	13.1	3.25	4.02	14.8	3.47	4.25	15.6	3.37	4.62	15.8	2.85	5.55
30	9.28	3.37	2.75	12.9	3.93	3.29	14.8	3.95	3.74	15.2	3.75	4.04	15.1	3.19	4.75
35	8.87	4.01	2.21	12.4	4.51	2.75	13.6	4.19	3.24	14.2	3.94	3.60	14.7	3.64	4.05
40	7.28	3.89	1.87	9.18	3.78	2.43	10.2	3.49	2.93	12.0	3.75	3.21	13.2	3.43	3.84
43	4.91	3.55	1.38	5.76	3.08	1.87	7.17	2.89	2.48	8.98	3.20	2.81	9.46	2.72	3.48
Minimum															
DB	LWT														
	5			10			15			20			25		
	CC	PI	EER	CC	PI	EER	CC	PI	EER	CC	PI	EER	CC	PI	EER
-5	/	/	/	/	/	/	5.22	0.59	8.92	5.73	0.65	8.86	6.30	0.63	10.08
0	/	/	/	/	/	/	5.13	0.73	7.01	6.04	0.69	8.75	6.61	0.70	9.47
5	/	/	/	/	/	/	4.12	0.65	6.37	5.21	0.59	8.80	5.68	0.62	9.15
10	/	/	/	/	/	/	5.06	0.82	6.16	5.91	0.72	8.20	6.40	0.73	8.75
15	/	/	/	5.23	0.98	5.32	6.08	0.95	6.41	6.91	0.83	8.37	8.14	0.88	9.21
20	3.54	0.88	4.04	4.97	1.11	4.49	6.53	1.27	5.15	8.01	1.37	5.86	8.65	1.26	6.86
25	4.43	1.26	3.52	5.42	1.28	4.22	6.98	1.56	4.47	8.21	1.69	4.85	8.60	1.48	5.81
30	4.41	1.57	2.81	5.31	1.54	3.44	6.92	1.77	3.91	7.92	1.86	4.26	8.15	1.66	4.92
35	4.04	1.78	2.27	5.75	2.00	2.87	6.79	1.96	3.47	7.56	1.94	3.90	8.12	1.87	4.33
40	3.29	1.76	1.86	4.30	1.72	2.50	5.01	1.65	3.03	6.43	1.93	3.33	7.52	1.92	3.91
43	1.68	1.19	1.41	2.76	1.43	1.93	3.75	1.45	2.58	4.57	1.58	2.89	6.03	1.67	3.61

Abbreviations:

LWT: Leaving water temperature (°C)

DB: Dry-bulb temperature for Outdoor air temperature (°C)

CC: Total cooling capacity (kW)

PI: Power input (kW)

6 Operating Limits

Figure 2-6.1: Heating operating limits<sup>1</sup>

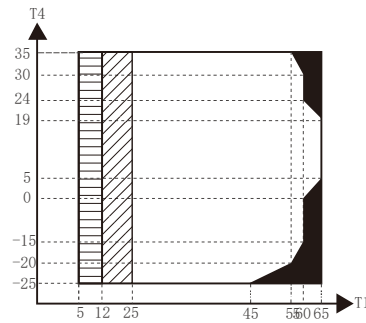

Figure 2-6.2: Cooling operating limits

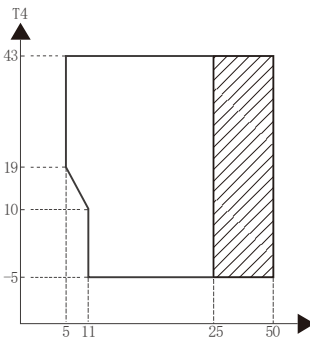
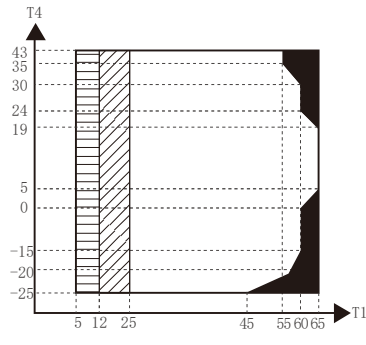

Figure 2-6.3: Domestic hot water operating limits<sup>1</sup>



Abbreviations:

T4: Outdoor temperature (°C)

T1: Leaving water temperature (°C)

Notes:

1. If IBH/AHS setting is valid, only IBH/AHS turns on; If IBH/AHS setting is invalid, only heat pump turns on
2. Water flow temperature drop or rise interval
3. IBH/AHS only

**7 Hydronic Performance**

Figure 2-7.1: MSH-60IB; MSH-60IB/3; MSH-100IB; MSH-100IB/3; MSH-100IB-3/9 hydronic performance

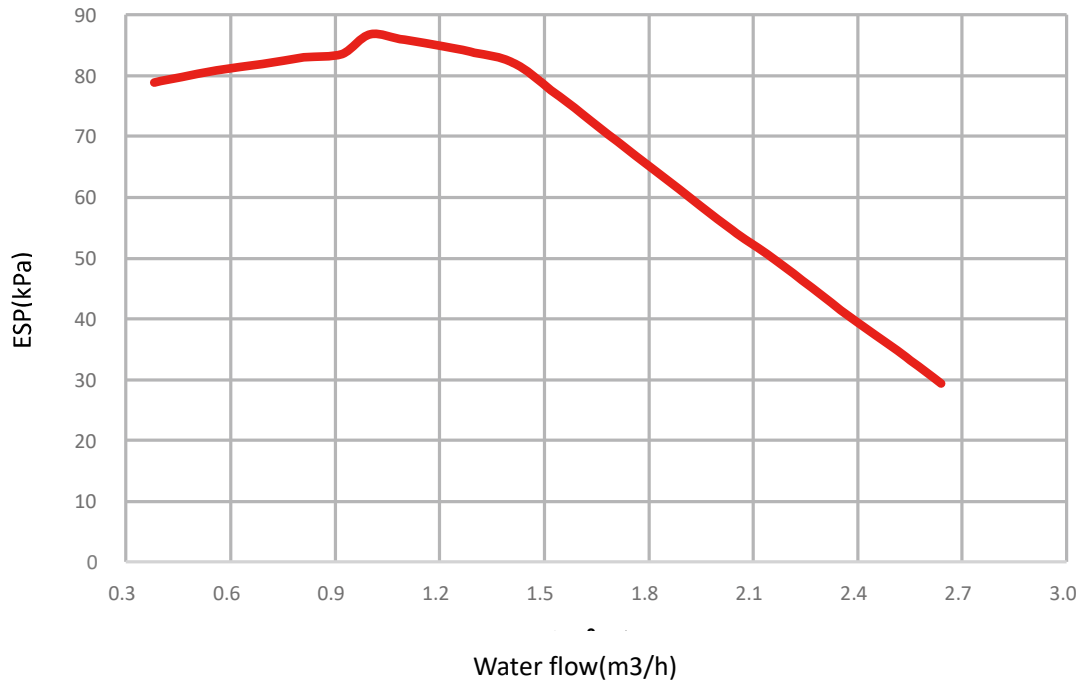
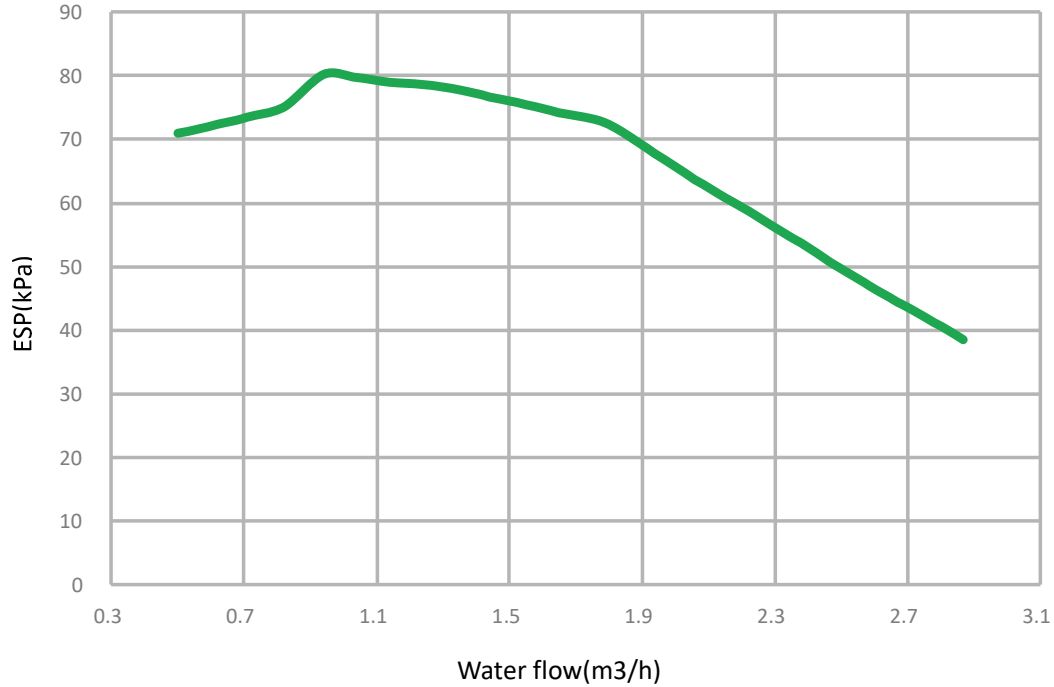

Figure 2-7.2: MSH-160IB; MSH-160IB/3; MSH-160IB-3/9 hydronic performance



## 8 Sound Levels

### 8.1 Overall

Table 2-8.1: Sound pressure levels<sup>1</sup>

Model name	dB
MSH-40EB	44
MSH-60EB	45
MSH-80EB	46
MSH-100EB	49
MSH-120EB-3	50
MSH-140EB-3	51
MSH-160EB-3	55
MSH-120EB-3	50
MSH-140EB-3	51
MSH-160EB-3	55

Notes:

- Sound pressure level is measured at a position 1m in front of the unit and  $(1+H)/2$ m (where H is the height of the unit) above the floor in a semi-anechoic chamber. During in-situ operation, sound pressure levels may be higher as a result of ambient noise. Sound pressure level is the maximum value tested under the two conditions of Notes2 and Notes3. For 16kW model, the value is calculated and it is for reference only

Figure 2-8.1: Sound pressure level measurement (unit: mm)

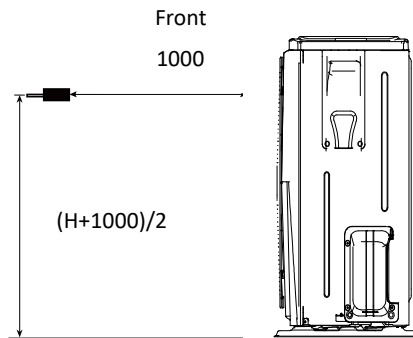

- Outdoor air temperature 7°C DB, 85% R.H.; EWT 30°C, LWT 35°C.
- Outdoor air temperature 35°C DB; EWT 23°C, LWT 18°C..

## 8.2 Octave Band Levels

Figure 2-8.2: MSH-40EB octave band levels

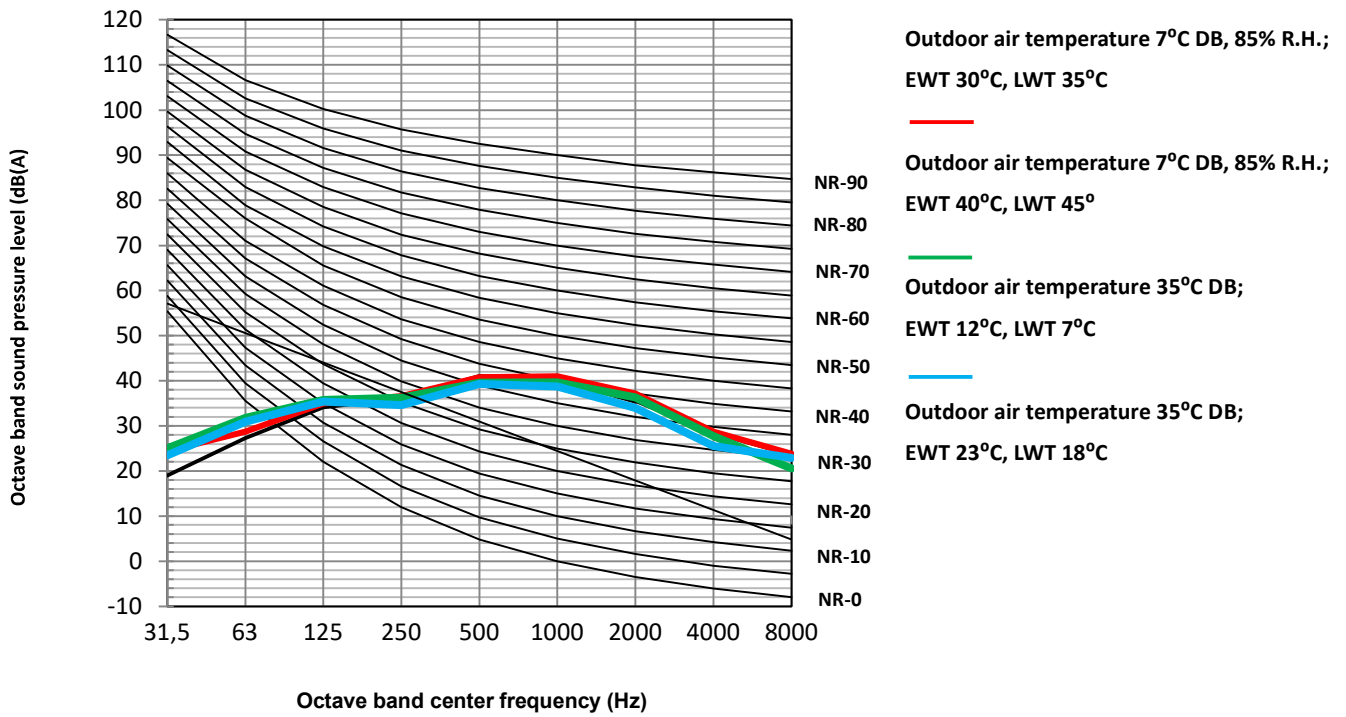

Figure 2-8.3: MSH-60EB octave band levels

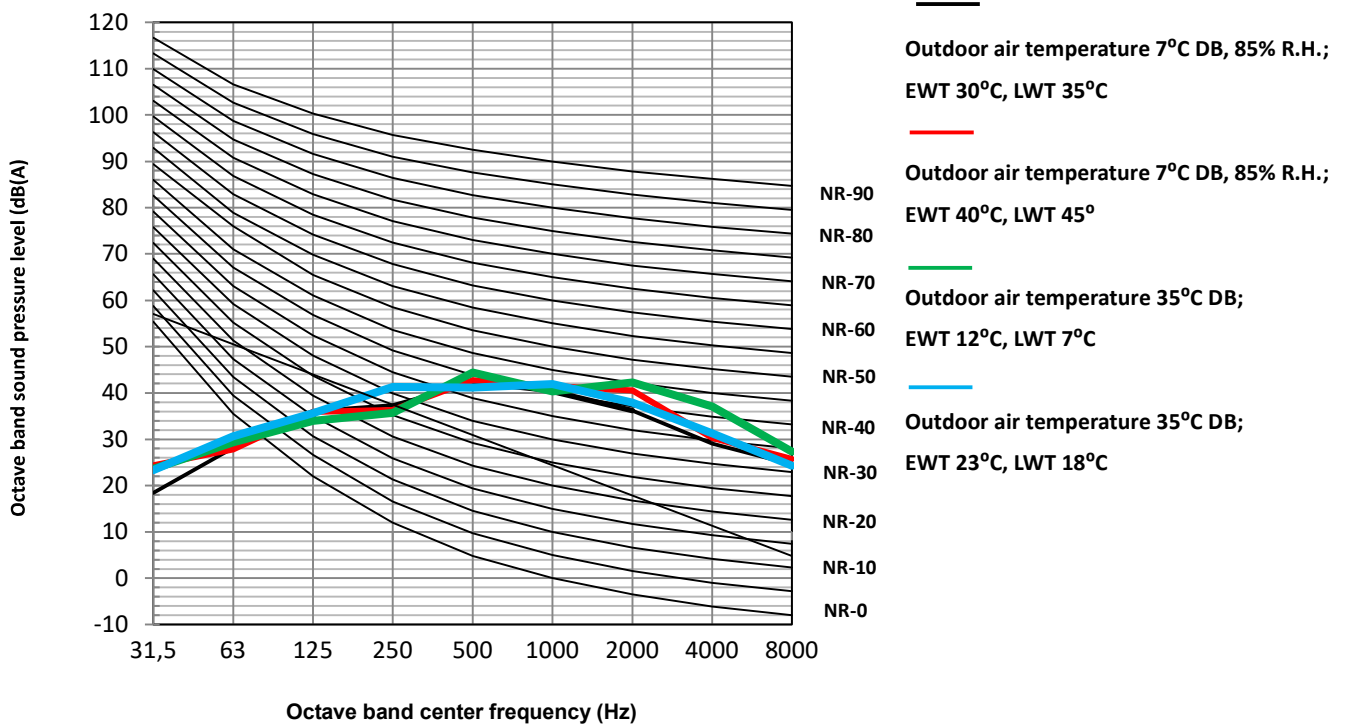

Figure 2-8.4: MSH-80EB octave band levels

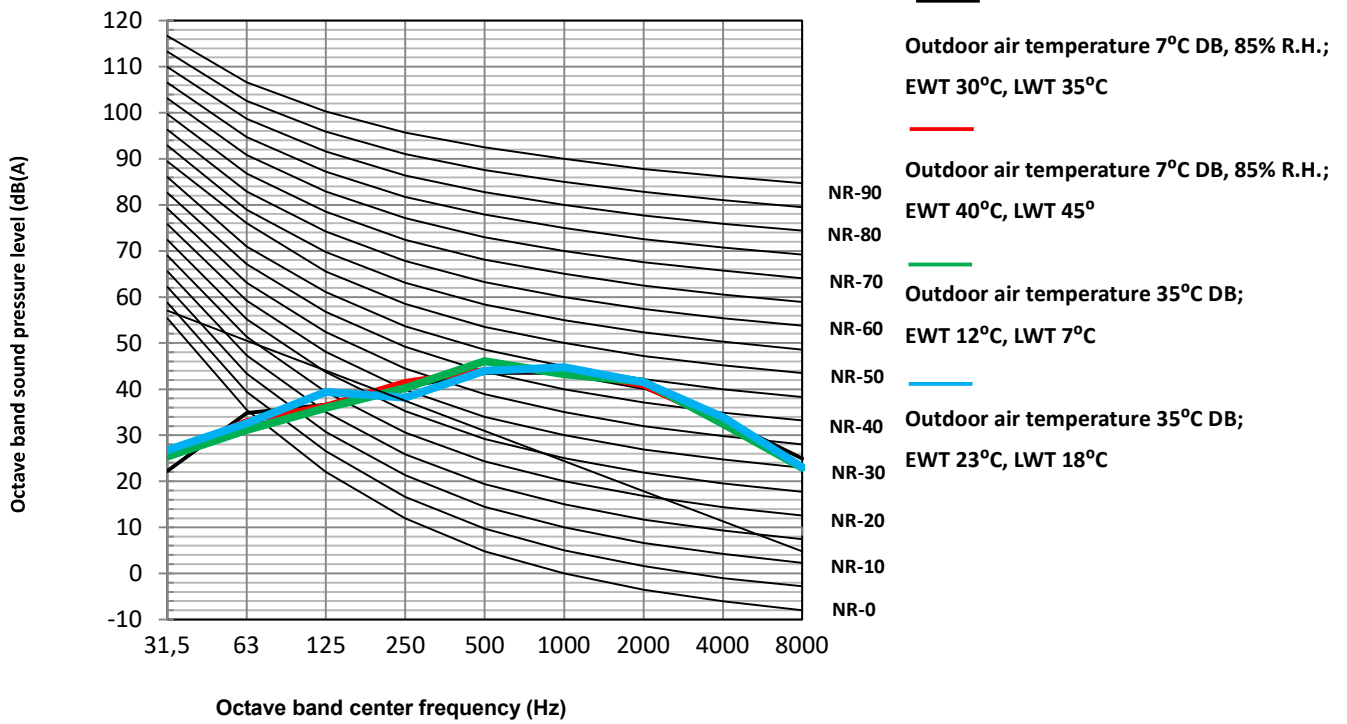

Figure 2-8.5: MSH-100EB octave band levels

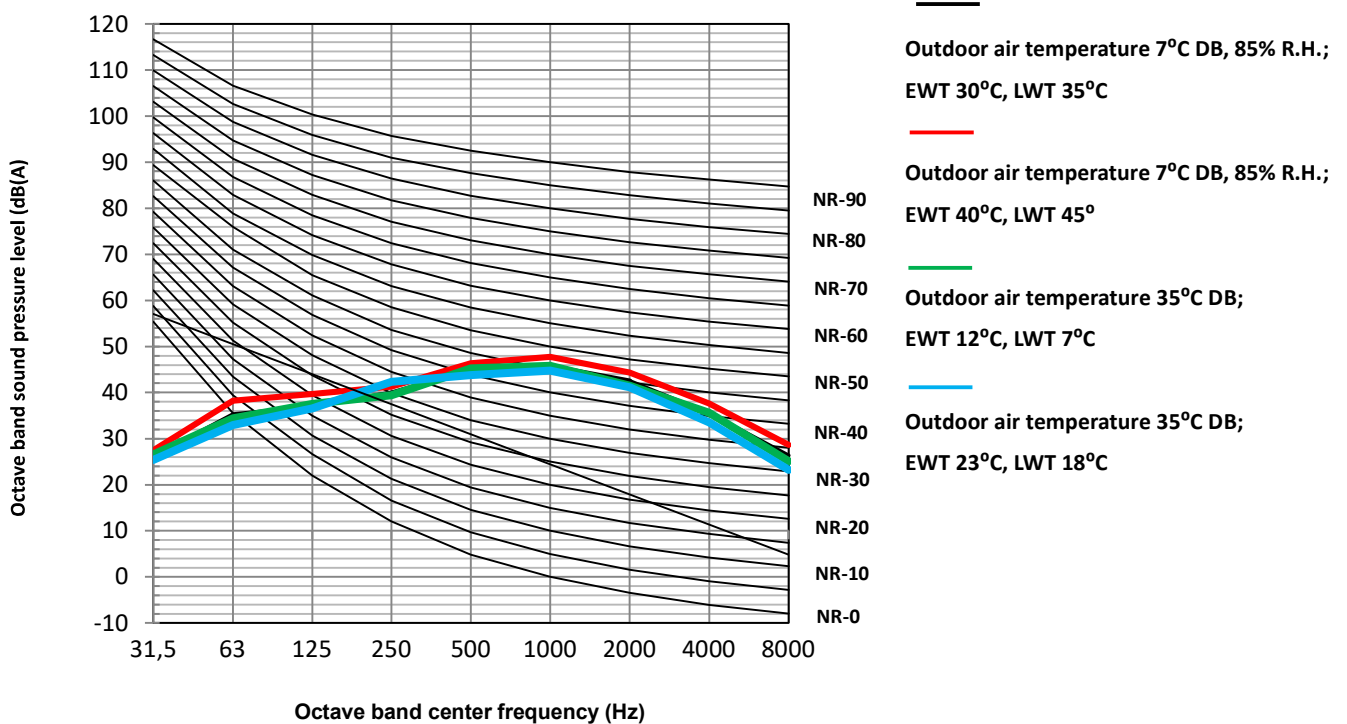

Figure 2-8.5: MSH-120EB octave band levels

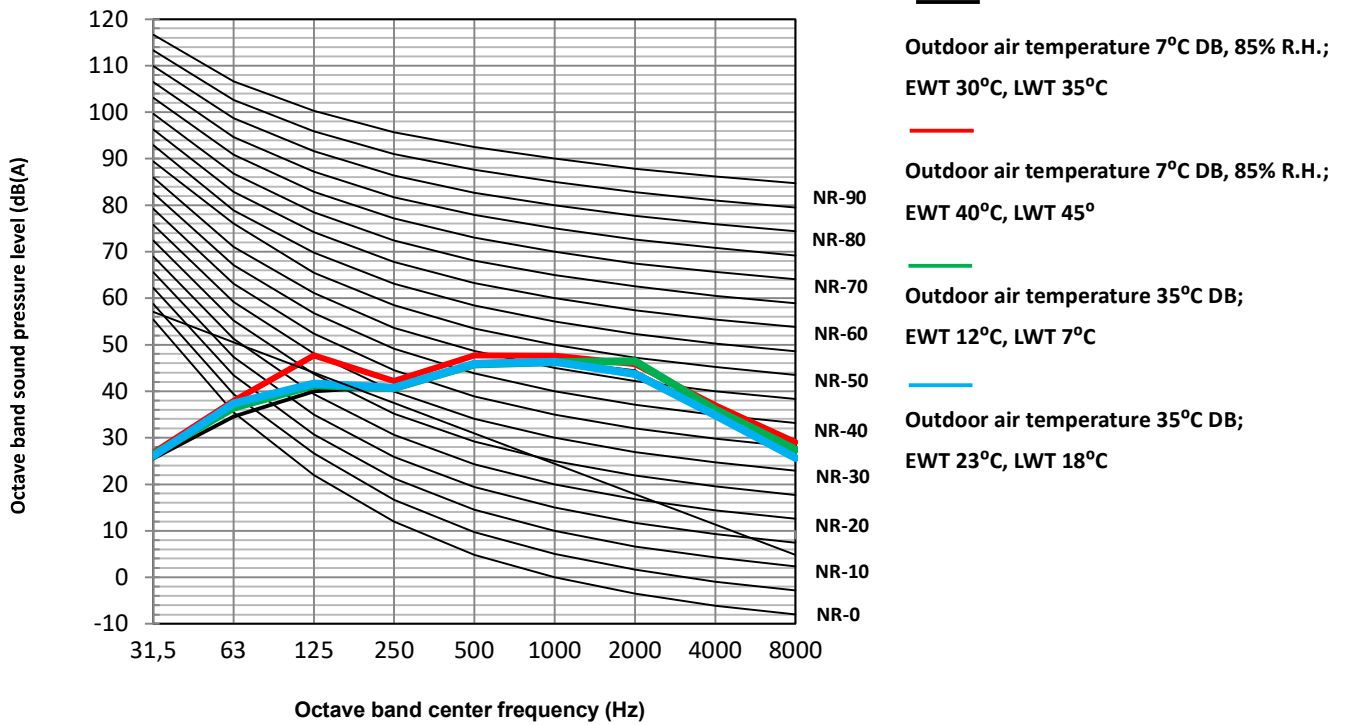
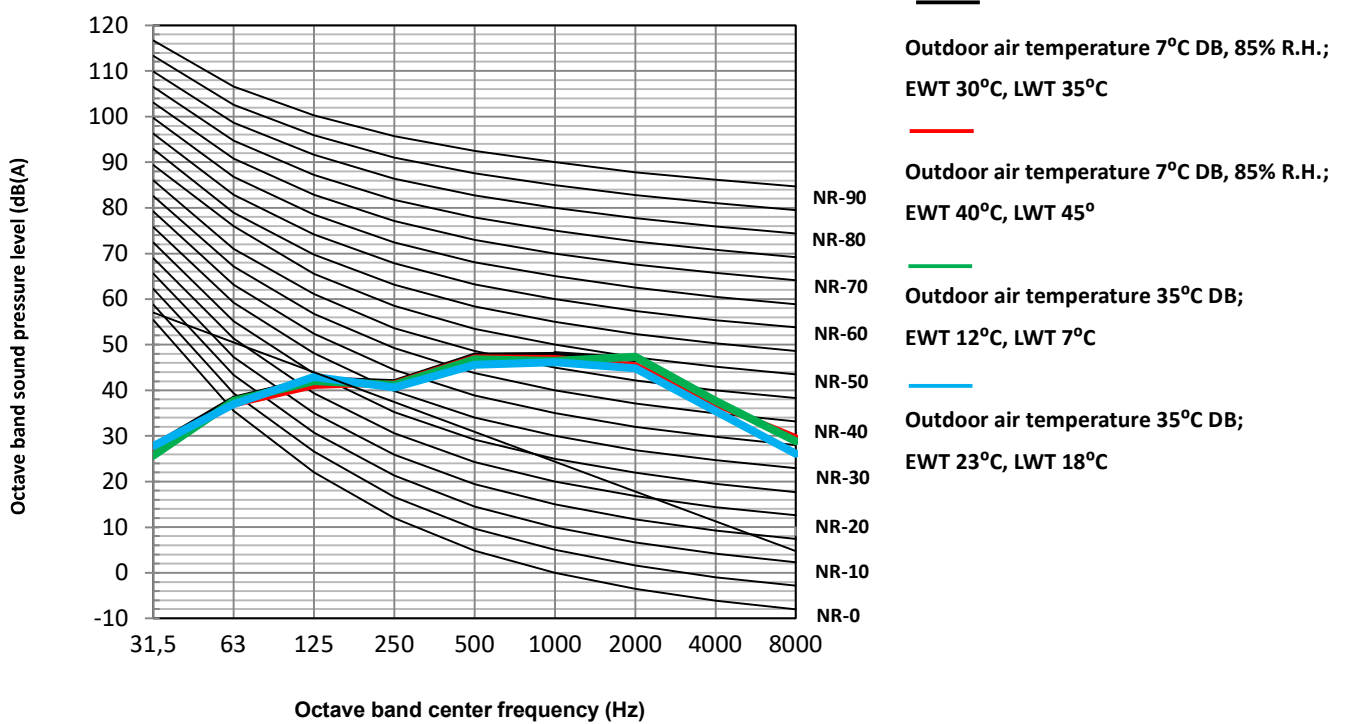

Figure 2-8.5: MSH-140EB octave band levels



# S-Therm Yukon split series



Figure 2-8.5: MSH-120EB-3 octave band levels

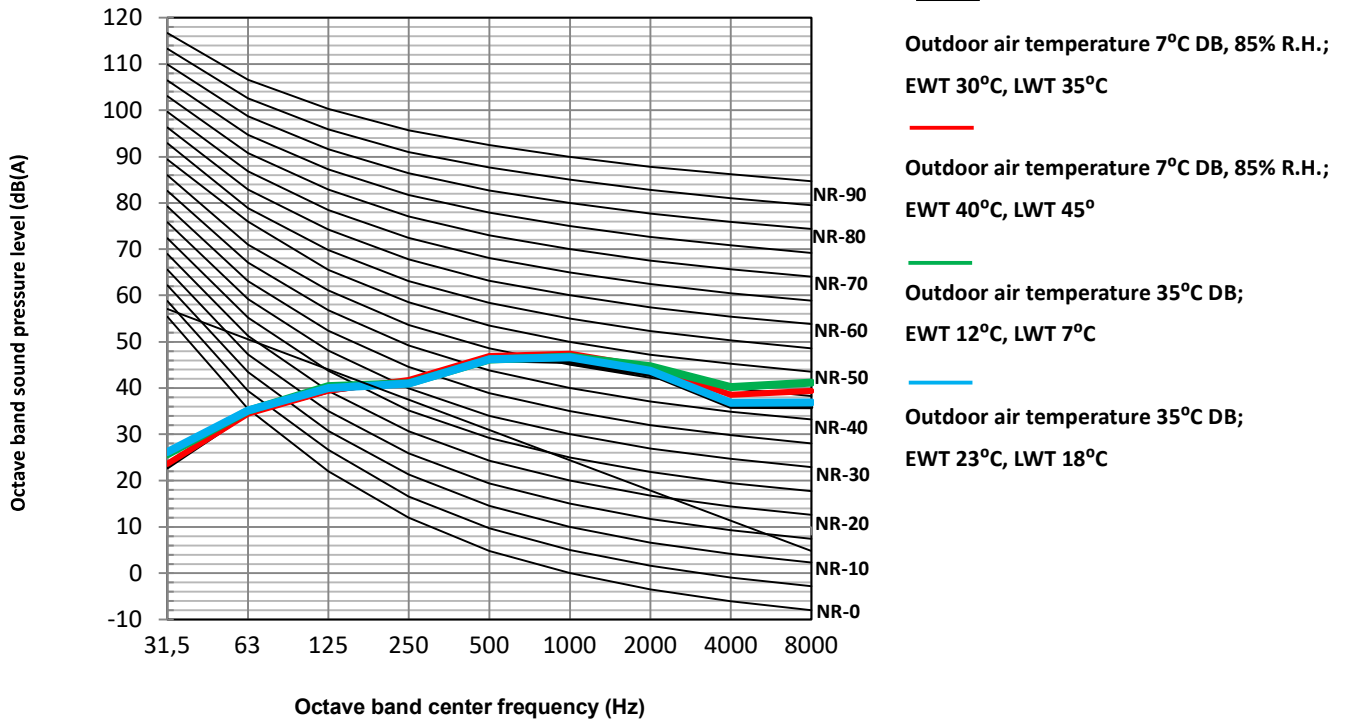
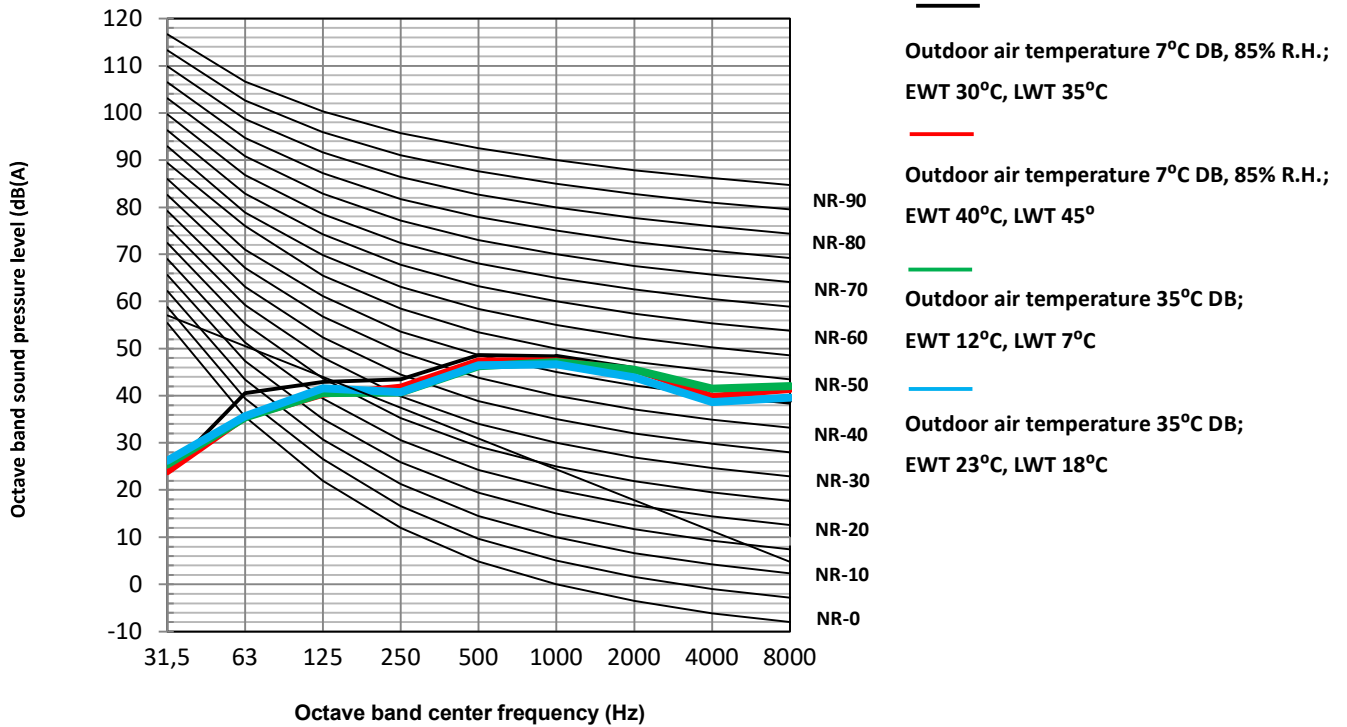





Figure 2-8.5: MSH-140EB-3 octave band levels



## 9 Accessories











### 9.1 Outdoor Unit

*Table 2-9.1: Outdoor unit accessories*

Name	Shape	Quantity
Outdoor unit installation and owner's manual		1
Technical data manual		1
Water outlet connection pipe assembly		1
Energy label		1

### 9.2 Hydronic Box

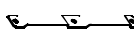
*Table 2-9.2: Hydronic box accessories*

Name	Shape	Quantity		
		MSH-60IB; MSH-60IB/3	MSH-100IB MSH-100IB/3 MSH-100IB-3/9	MSH-160IB MSH-160IB/3 MSH-160IB-3/9
Indoor unit installation and owner's manual		1	1	1
Operation manual		1	1	1
M16 Copper Nut Tamper Cap		1	1	1
M9 Copper Nut Tamper Cap		0	1	1
M6 Copper Nut Tamper Cap		1	0	0
M8 expansion screws		5	5	5
Temperature sensor for domestic hot water tank or zone 2 water flow		1	1	1
M16 Copper nut		1	1	1
Y-shaped filter		1	1	1
Mounting bracket		1	1	1
Operation manual(Wired controller)		1	1	1

# Part 7

# Installation and Field Settings

1 Preface to Part 7.....	169
2 Installation.....	170
3 Refrigerant Pipework .....	178
4 Water Pipework .....	191
5 Electrical Wiring .....	194
6 DIP Switch Settings.....	197
7 Internal Circulator Pump .....	197
8 User Interface Field Settings.....	198
9 Operation parameter .....	218
10 Network Configuration Guidelines .....	219
11 USB Function Guidelines .....	223
12 Climate Related Curves.....	227
13 Error Code Table.....	231

## 1 Preface to Part 7

### Notes for installers



- Notes for installers boxes contain important information which may primarily be of use during field installation, rather than during desk-based system design.

### 1.1 Definitions

In this Engineering Data Book, the term “applicable legislation” refers to all national, local and other laws, standards, codes, rules, regulations and other legislation that apply in a given situation.

### 1.2 Precautions

All system installation including installation of refrigerant piping, water piping and electrical works must only be carried out by competent and suitably qualified, certified and accredited professionals and in accordance with all applicable legislation.

## S-Therm Yukon split series

### 2 Installation

#### 2.1 Acceptance and Unpacking

##### Notes for installers



- When units are delivered check whether any damage occurred during shipment. If there is damage to the surface or outside of a unit, submit a written report to the shipping company.
- Check that the model, specifications and quantity of the units delivered are as ordered.
- Check that all accessories ordered have been included. Retain the Owner's Manual for future reference.

#### 2.2 Hoisting

##### Notes for installers



- Do not remove any packaging before hoisting. If units are not packaged or if the packaging is damaged, use suitable boards or packing material to protect the units.
- Hoist one unit at a time, using two ropes to ensure stability.
- Keep units upright during hoisting the outdoor unit, ensuring that the angle to the vertical does not exceed 30°.

## 2.3 Outdoor unit

### 2.3.1 Placement Considerations

Placement of the outdoor unit should take account of the following considerations:

- Outdoor units should not be exposed to direct radiation from a high-temperature heat source.
- Outdoor units should not be installed in positions where dust or dirt may affect heat exchangers.
- Outdoor units should not be installed in locations where exposure to oil or to corrosive or harmful gases, such as acidic or alkaline gases, may occur.
- Outdoor units should not be installed in locations where exposure to salinity may occur.
- Outdoor units should be installed in well-drained, well-ventilated positions.
- Outdoor units should be installed in locations where the noise from the unit will not disturb neighbors.

### 2.3.2 Strong Wind Installation

Wind of 5m/s or more blowing against an outdoor unit's air outlet blocks the flow of air through the unit, leading to deterioration in unit capacity, accelerated frost accumulation when in heating mode or domestic hot water mode, and potential disruption to operation due to increased pressure in the refrigerant circuit. Exposure to very strong wind can also cause the fan to rotate excessively fast, potentially leading to damage to the fan. In locations where exposure to high winds may occur should take account of the following considerations:

- For installation of the outdoor unit in a place where the wind direction can be foreseen. Set the outlet side at a right angle to the direction of the wind, refer to Figure 3-2.1.
- If turn the air outlet side toward the building's wall, fence or screen. Make sure there is enough room to do the installation

Figure 3-2.1: Strong wind installation direction

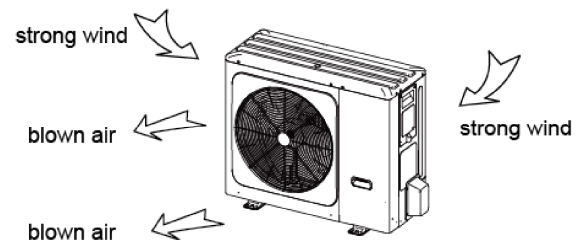

### 2.3.3 Cold Climate Installation

In cold climate locations installation should take account of the following considerations:

- Never install the unit at a site where the suction side may be exposed directly to wind.
- To prevent exposure to wind, install a baffle plate on the air discharge side of the unit.
- To prevent exposure to wind, install the unit with its suction side facing the wall.
- In areas of heavy snowfall, a canopy should be installed to prevent snow entering the unit. Additionally, the height of the base structure should be increased so as to raise the unit further off the ground. Refer to Figure 3-2.2.

Figure 3-2.2: Snow shielding

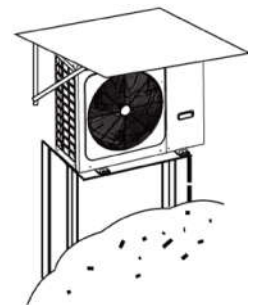

### 2.3.4 Hot Climate Installation

As the outdoor temperature is measured via the outdoor unit air thermistor, make sure to install the outdoor unit in the shade or a canopy should be constructed to avoid direct sunlight, so that it is not influenced by the sun's heat, otherwise protection may be possible to the unit.

### 2.3.5 Base Structure

Outdoor unit base structure design should take account of the following considerations:

- A solid base prevents excess vibration and noise. Outdoor unit bases should be constructed on solid ground or on structures of sufficient strength to support the unit's weight.
- Bases should be at least 100mm high to provide sufficient drainage and to prevent water ingress into the base of the unit.
- Either steel or concrete bases may be suitable.
- Outdoor units should not be installed on supporting structures that could be damaged by water build-in in the event

## S-Therm Yukon split series

of a blocked drain.

- Fix the unit securely to foundation by means of the  $\Phi 10$  expansion bolt. It is best to screw in the foundation bolts until their length is 20 mm from the foundation surface.

Figure 3-2.3: Outdoor unit fixing

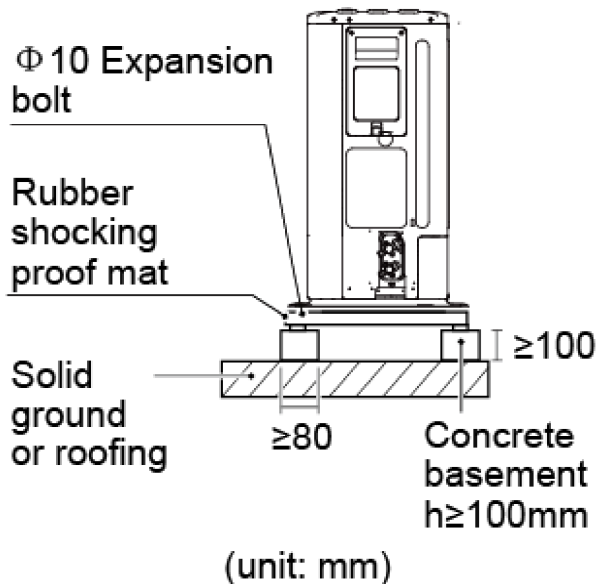

### 2.3.6 Drainage

Drainage ditch should be provided to allow drainage of condensate that may form on the air side heat exchanger when the unit is running in heating mode or domestic hot water mode. The drainage should ensure that condensate is directed away from roadways and footpaths, especially in locations where the climate is such that condensate may freeze.

Figure 3-2.4: 4-6kW models drainage hole

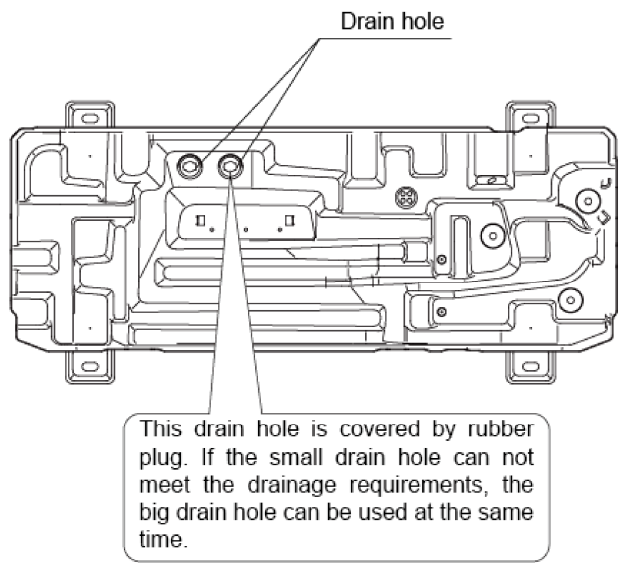
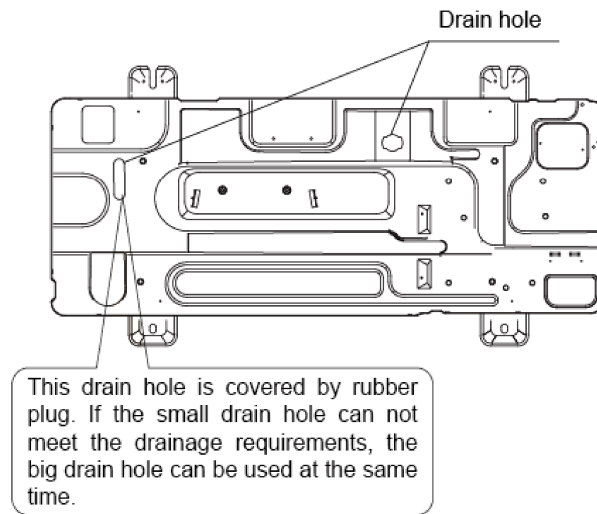

Figure 3-2.5: 8-16kW models drainage hole



### 2.3.7 Transportation support

For 12/14/16kW model, there is a transportation support which is used to protect tubes from breaking during transportation and this support should be taken off before turning on the heat pump.

Figure 3-2.6: 12-16kW models 2.3.7 transportation support

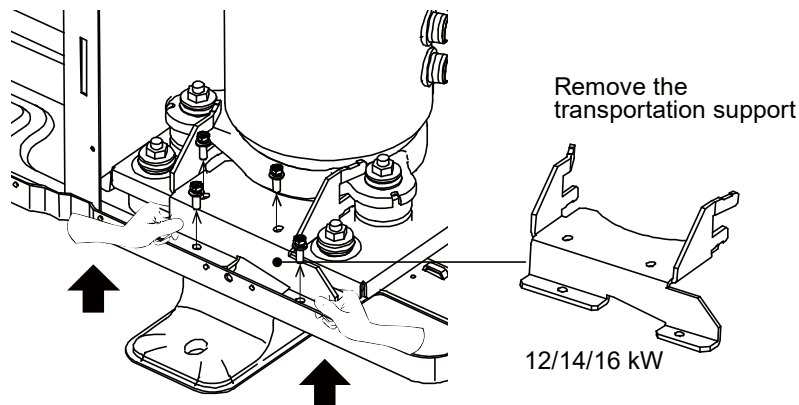

### 2.3.8 Spacing

#### Single unit installation

Outdoor unit must be spaced such that sufficient air may flow through each unit. Sufficient airflow across heat exchangers is essential for outdoor units to function properly.

Figure 3-2.7: Single unit installation requirement (Unit: mm)

# S-Therm Yukon split series

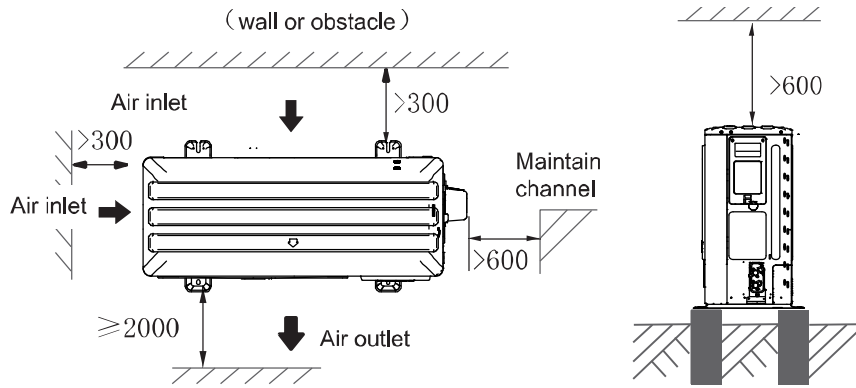

## Stacked installation

Figure 3-2.8: Installation with obstacles in front of the unit

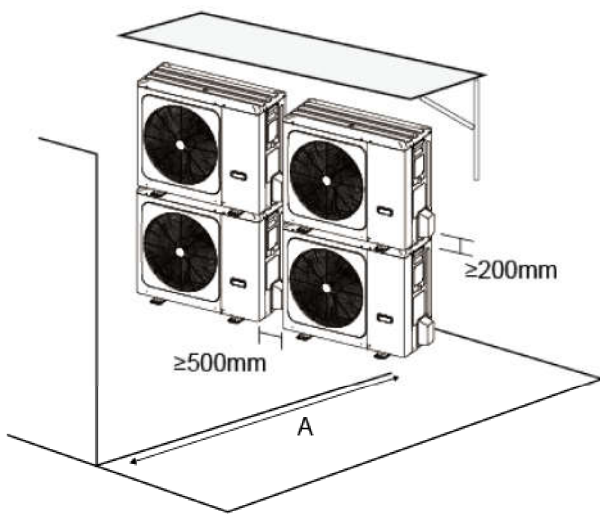
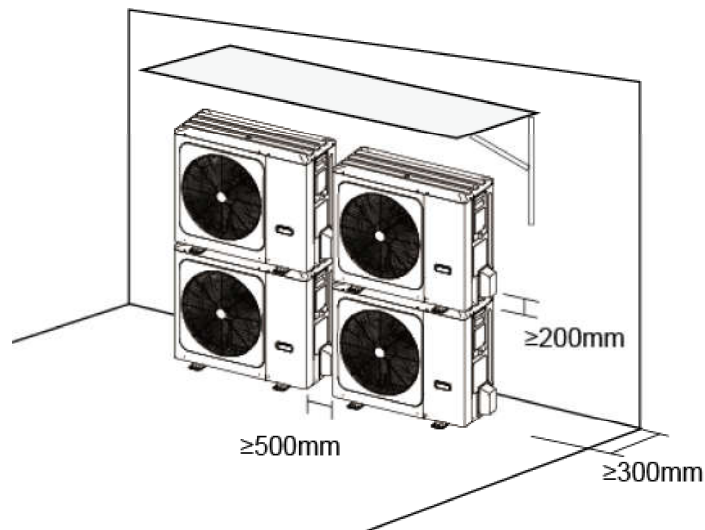

Table 3-2.1: Minimum spacing from obstacles in front of the unit

Model name	A (mm)
MSH-40EB	2000
MSH-60EB	
MSH-80EB	
MSH-100EB	
MSH-120EB	
MSH-140EB	
MSH-160EB	
MSH-120EB-3	
MSH-140EB-3	
MSH-160EB-3	

Figure 3-2.9: Installation with obstacles behind the unit



## Installation in Rows

Figure 3-2.10: Single row installation

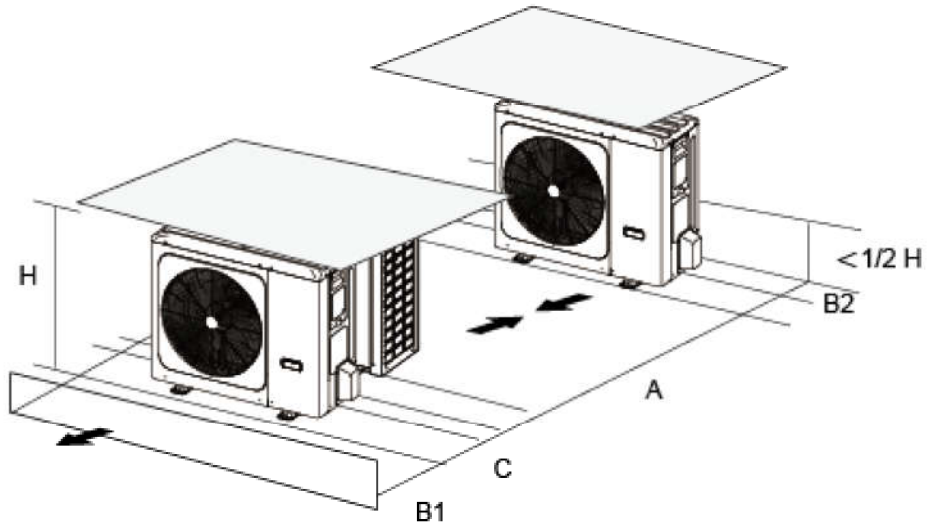

Table 3-2.2: Single row installation spacing requirements

Model name	A (mm)	B1 (mm)	B2 (mm)	C (mm)
MSH-40EB				
MSH-60EB				
MSH-80EB				
MSH-100EB				
MSH-120EB	$\geq 3000$	$\geq 2000$	$\geq 150$	$\geq 600$
MSH-140EB				
MSH-160EB				
MSH-120EB-3				
MSH-140EB-3				
MSH-160EB-3				

Figure 3-2.11: Multi-row installation

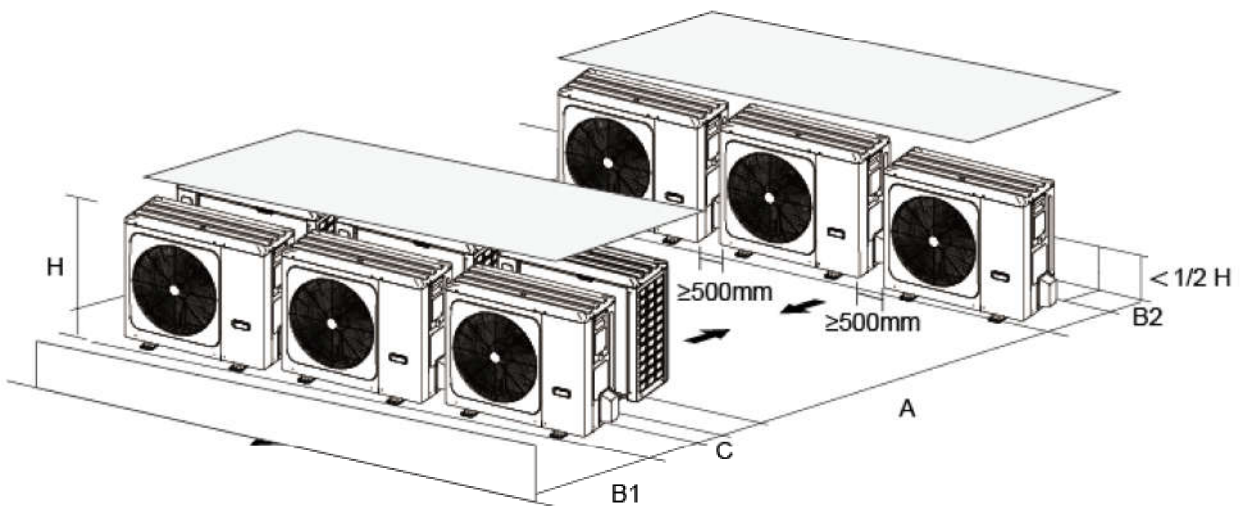

Table 3-2.3: Multiple row installation spacing requirements

Model name	A (mm)	B1 (mm)	B2 (mm)	C (mm)
MSH-40EB	≥3000	≥2000	≥300	≥600
MSH-60EB				
MSH-80EB				
MSH-100EB				
MSH-120EB				
MSH-140EB				
MSH-160EB				
MSH-120EB-3				
MSH-140EB-3				
MSH-160EB-3				

## 2.4 Hydronic box

### 2.4.1 Placement Considerations

- Hydronic box should be installed in positions that are as close as possible to the heat emitters.
- Hydronic box should be installed in positions that are sufficiently close to the desired position of the wired controller that the controller’s wiring length limitation will not be exceeded.
- In systems that are configured to heat domestic hot water, hydronic box should be installed in positions that are sufficiently close to the domestic hot water tank that the temperature sensor wiring length limitations will not be exceeded.

### 2.4.2 Mounting the hydronic box

- Fix the wall mounting bracket to the wall using appropriate plugs and screws.

Figure 3-2.12: Wall bracket

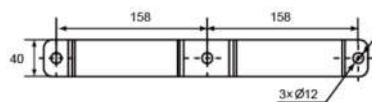
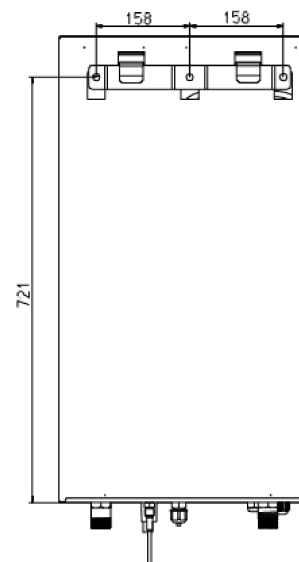
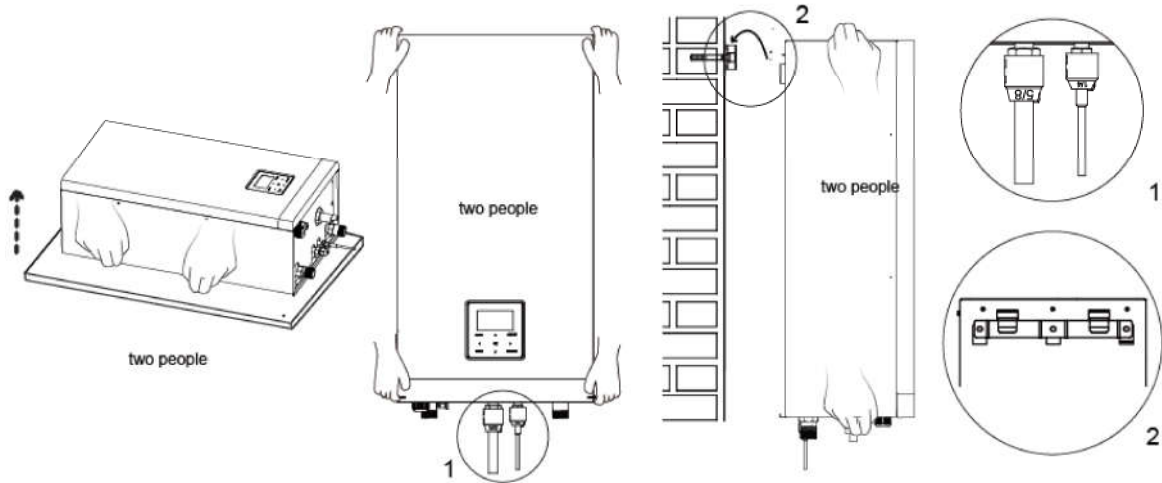

Figure 3-2.13: Hydronic box backside



- Make sure the wall mounting bracket is completely level. When the unit is not installed level, air might get trapped in the water circuit resulting in malfunctioning of the unit. Pay special attention to this when installing the hydronic box to prevent overflow of the drain pan.
- Hang the hydronic box on the wall mounting bracket.
- Fix the hydronic box at the bottom inside using appropriate plugs and screws. The hydronic box is equipped with 2 holes at the bottom outer edges of the frame.

Figure 3-2.14: Fix hydronic box



### 2.4.3 Service space requirement

The service space requirements refer to Figure 3-2.15.

Figure 3-2.15: Service space requirement (unit:mm)

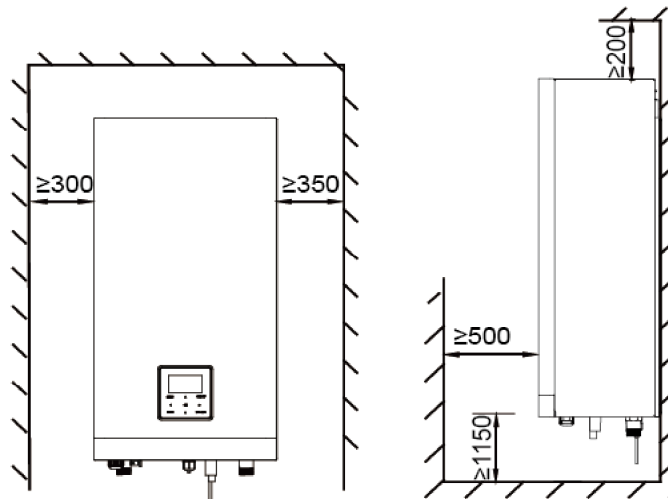

### 2.4.4 Drainage

The drainage connections of hydronic box refer to Figure 3-2.16.

Figure 3-2.16: Drainage

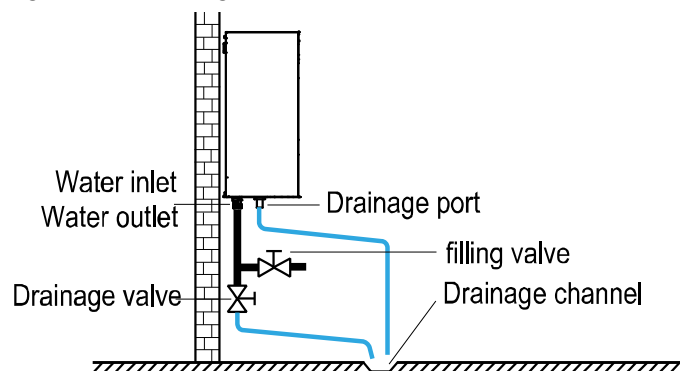

# S-Therm Yukon split series

## 3 Refrigerant Pipework

### 3.1 Permitted Piping Length and Level Difference

The piping length and level difference limitations that apply are summarized in Table 3-3.1. Before installation, it is necessary to check if the piping length and height difference are meeting the requirements.

Table 3-3.1: Permitted Piping Length and Level Difference

Models	4-16kW
Max. piping length	30m
Max. difference in height	20m

Figure 3-3.1: Connect method

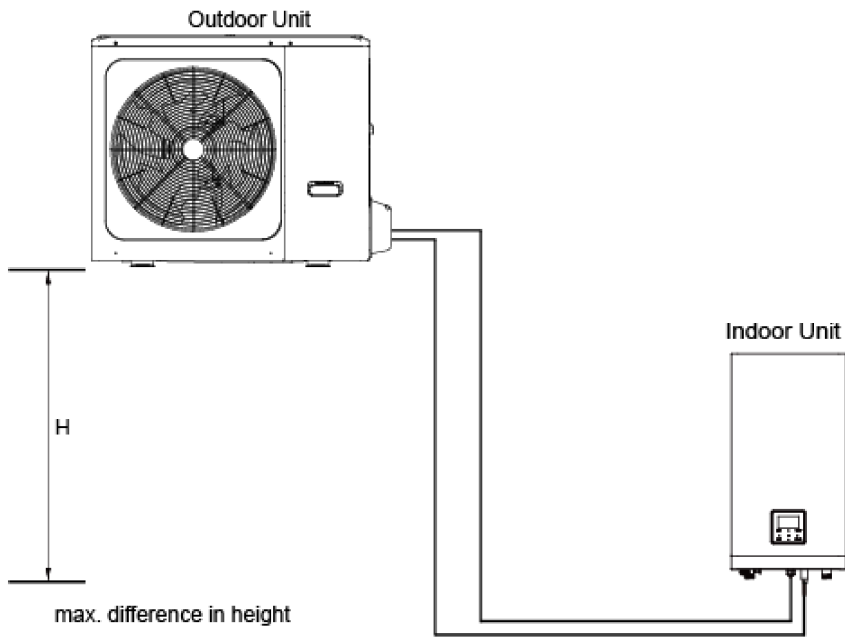

The largest level difference between indoor unit and outdoor unit should not exceed 20m.

### 3.2 Pipe Size and Connect method

Table 3-3.2: Refrigerant pipe connection

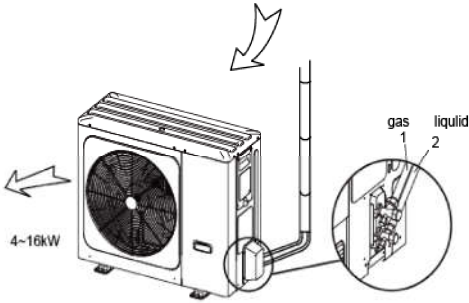
Models	4/6kW	8/10kW	12/14/16kW
Pipe connect			
Pipe size	Gas side (Φ15.9); Liquid side (Φ6.35);	Gas side (Φ15.9); Liquid side (Φ9.52);	Gas side (Φ15.9); Liquid side (Φ9.52);
Connect method	Flare	Flare	Flare

### 3.3 Procedure and Principles

#### 3.3.1 Installation procedure

##### Notes for installers



Installation of the refrigerant piping system should proceed in the following order:



Note: Pipe flushing should be performed once the brazed connections have been completed with the exception of the final connections to the indoor units. That is, flushing should be performed once the outdoor units have been connected but before the indoor units are connected.

#### 3.3.2 Three principles for refrigerant piping

	Reasons	Measures
CLEAN	Particles such as oxide produced during brazing and/or building dust can lead to compressor malfunction	<ul style="list-style-type: none"> <li>Seal piping during storage<sup>1</sup></li> <li>Flow nitrogen during brazing<sup>2</sup></li> <li>Pipe flushing<sup>3</sup></li> </ul>
DRY	Moisture can lead to ice formation or oxidization of internal components leading to abnormal operation or compressor damage	<ul style="list-style-type: none"> <li>Pipe flushing<sup>3</sup></li> <li>Vacuum drying<sup>4</sup></li> </ul>
SEALED	Imperfect seals can lead to refrigerant leakage	<ul style="list-style-type: none"> <li>Pipe manipulation<sup>5</sup> and brazing<sup>2</sup> techniques</li> <li>Gas tightness test<sup>6</sup></li> </ul>

Notes:

- See Part 3, 3.4.1 "Pipe delivery, storage and sealing".
- See Part 3, 3.7 "Brazing".
- See Part 3, 3.8 "Pipe Flushing".
- See Part 3, 3.10 "Vacuum Drying".
- See Part 3, 0 "Manipulating Copper Piping".
- See Part 3, 3.9 "Gas tightness Test".

### 3.4 Storing Copper Piping

#### 3.4.1 Pipe delivery, storage and sealing

##### Notes for installers



- Ensure that piping does not get bent or deformed during delivery or whilst stored.
- On construction sites store piping in a designated location.
- To prevent dust or moisture entering, piping should be kept sealed whilst in storage and until it is about to be connected. If piping is to be used soon, seal the openings with plugs or adhesive tape. If piping is to be stored for a long time, charge the piping with nitrogen at 0.2-0.5MPa and seal the openings by brazing.
- Storing piping directly on the ground risks dust or water ingress. Wooden supports can be used to raise piping off the ground.
- During installation, ensure that piping to be inserted through a hole in a wall is sealed to ensure dust and/or fragments of wall do not enter.
- Be sure to seal piping being installed outdoors (especially if being installed vertically) to prevent rain entering.

### 3.5 Manipulating Copper Piping

#### 3.5.1 De-oiling

##### Notes for installers



- Lubrication oil used during some copper pipe manufacturing processes can cause deposits to form in R32 refrigerant systems, causing system errors. Oil-free copper piping should therefore be selected. If ordinary (oily) copper piping is used, it must be cleaned with gauze dipped in tetrachloroethylene solution prior to installation.

##### Caution

- Never use carbon tetrachloride (CCl<sub>4</sub>) for pipe cleansing or flushing, as doing so will seriously damage the system.

#### 3.5.2 Cutting copper piping and removing burrs

##### Notes for installers



- Use a pipe cutter rather than a saw or cutting machine to cut piping. Rotate the piping evenly and slowly, applying even force to ensure that the piping does not become deformed during cutting. Using a saw or cutting machine to cut piping runs the risk of copper shavings entering the piping. Copper shavings are difficult to remove and pose a serious risk to the system if they enter the compressor or block the throttling unit.
- After cutting using a pipe cutter, use a reamer/scrapper to remove any burrs that have formed at the opening, keeping the opening of the piping downwards to avoid copper shavings from entering the piping.
- Remove burrs carefully to avoid scratches, which may prevent a proper seal being formed and lead to refrigerant leakage.

### 3.5.3 Expanding copper piping ends

#### Notes for installers



- Ends of copper piping can be expanded so that another length of piping can be inserted and the joint brazed.
- Insert the expanding head of the pipe expander into the pipe. After completing pipe expansion, rotate the copper pipe a few degrees to rectify the straight line mark left by the expanding head.

#### Caution

- Ensure that the expanded section of piping is smooth and even. Remove any burrs that remain after cutting.

Figure 3-3.2: Expanding copper piping ends

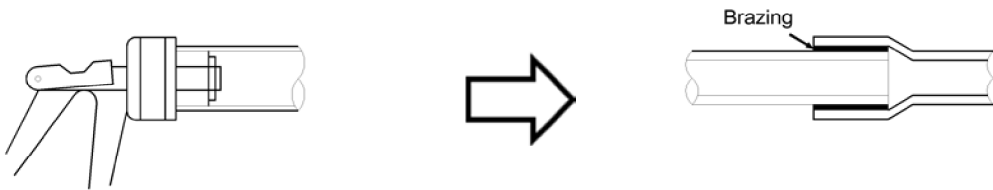

### 3.5.4 Flared joints

Flared joints should be used where a screw thread connection is required.

#### Notes for installers



- Before flaring 1/2H (half hard) piping, anneal the end of the pipe to be flared.
- Remember to place the flare nut on the piping before flaring.
- Ensure the flared opening is not cracked, deformed or scratched, otherwise it will not form a good seal and refrigerant leakage may occur.
- The diameter of the flared opening should be within the ranges specified in Table 3-3.3. Refer to Figure 3-3.3.

pipe (mm)	Flared opening diameter (A) (mm)
φ6.35	8.7 - 9.1
φ9.53	12.8 - 13.2
φ12.7	16.2 - 16.6
φ15.9	19.3 - 19.7
φ19.1	26.6 - 24.0

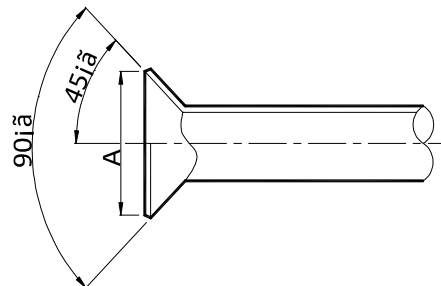

- When connecting a flared joint, apply some compressor oil to the inner and outer surfaces of the flared opening to facilitate the connection and rotation of the flare nut, ensure firm connection between the sealing surface and the bearing surface, and avoid the pipe becoming deformed.

### 3.5.5 Bending piping

Bending copper piping reduces the number of brazed joints required and can improve quality and save material.

#### Notes for installers



##### Piping bending methods

- Hand bending is suitable for thin copper piping ( $\Phi 6.35\text{mm} - \Phi 12.7\text{mm}$ ).
- Mechanical bending (using a bending spring, manual bending machine or powered bending machine) is suitable for a wide range of diameters ( $\Phi 6.35\text{mm} - \Phi 54.0\text{mm}$ ).

##### Caution

- When using a spring bender, ensure that the bender is clean before inserting it in the piping.
- After bending a copper pipe, ensure that there are no wrinkles or deformation on either side of the pipe.
- Ensure that bend angles do not exceed  $90^\circ$ , otherwise wrinkles may appear on the inner side of the pipe, and the pipe may buckle or crack. Refer to Figure 3-3.4.
- Do not use a pipe that has buckled during the bending process; ensure that the cross section at the bend is greater than  $2/3$  of the original area.

Figure 3-3.4: Pipe bending in excess of  $90^\circ$

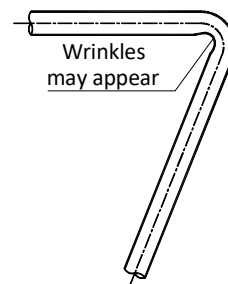

### 3.6 Refrigerant Piping Supports

When the air conditioning is running, the refrigerant piping will deform (shrink, expand and droop). To avoid damage to piping, hangers or supports should be spaced as per the criteria in the Table 3-3.4. In general, the gas and liquid pipes should be suspended in parallel and the interval between support points should be selected according to the diameter of the gas pipe.

Table 3-3.4: Refrigerant piping support spacings

Pipe (mm)	Interval between support points (m)	
	Horizontal Piping	Vertical Piping
< $\Phi 20$	1	1.5
$\Phi 20 - \Phi 40$	1.5	2
> $\Phi 40$	2	2.5

Suitable insulation should be provided between the piping and the supports. If wooden dowels or blocks are to be used, use wood that has undergone preservative treatment.

Changes in refrigerant flow direction and refrigerant temperature result in movement, expansion and shrinkage of the refrigerant piping. Piping should therefore not be fixed too tightly, otherwise stress concentrations may occur in the piping, with the potential for rupturing.

### 3.7 Brazing

Care must be taken to prevent oxide forming on the inside of copper piping during brazing. The presence of oxide in a refrigerant system adversely affects the operation of valves and compressors, potentially leading to low efficiency or even compressor failure. To prevent oxidation, during brazing nitrogen should be flowed through the refrigerant piping.

#### Notes for installers



#### Warning

- Never flow oxygen through piping as doing so aids oxidation and could easily lead to explosion and as such is extremely dangerous.
- Take appropriate safety precautions such as having a fire extinguisher to hand whilst brazing.

#### Flowing nitrogen during brazing

- Use a pressure reducing valve to flow nitrogen through copper piping at 0.02-0.03MPa during brazing.
- Start the flow before brazing starts and ensure that the nitrogen continuously passes through the section being brazed until the brazing is complete and the copper has cooled down completely.

Figure 3-3.5: Flowing nitrogen through piping during brazing

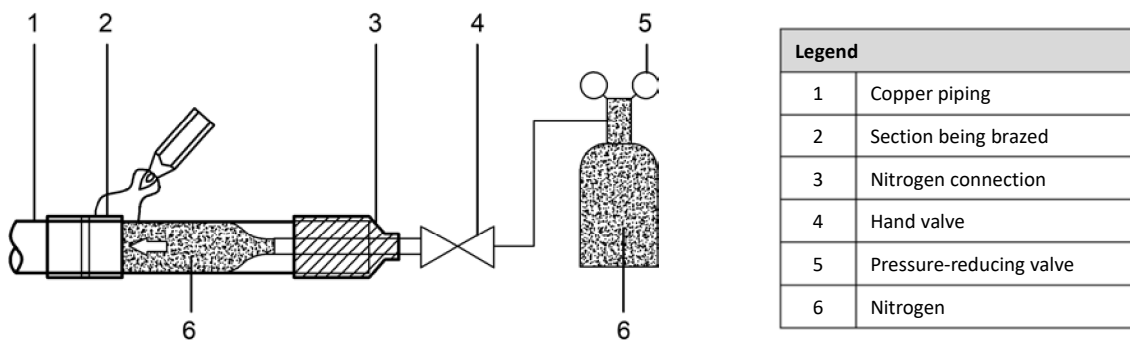

- When joining a shorter section of piping to a longer section, flow nitrogen from the shorter side to allow better displacement of air with nitrogen.
- If the distance from the point where nitrogen enters the piping to the joint to be brazed is long, ensure that the nitrogen is flowed for sufficient time to discharge all the air from the section to be brazed before commencing brazing.

Figure 3-3.6: Flowing nitrogen from shorter side during brazing

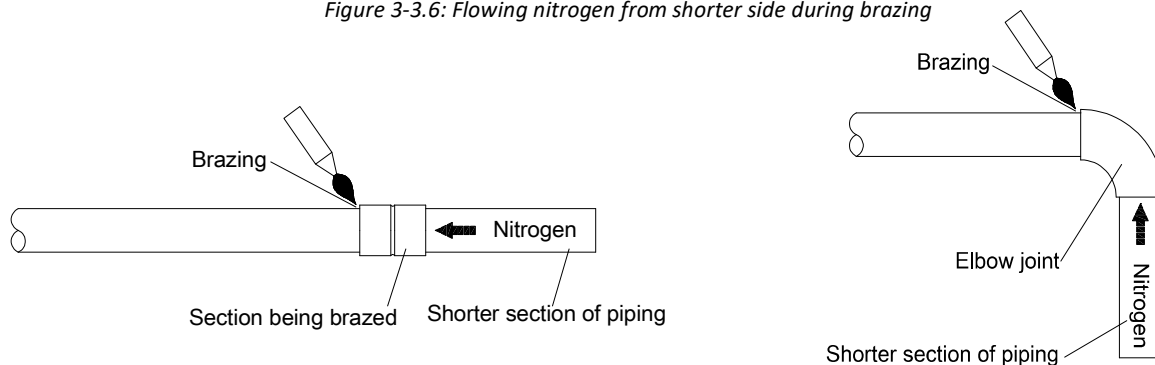

Box continued on next page ...

... box continued from previous page

**Piping orientation during brazing**

Brazing should be conducted downwards or horizontally to avoid filler leakage.

Figure 3-3.7: Piping orientation during brazing

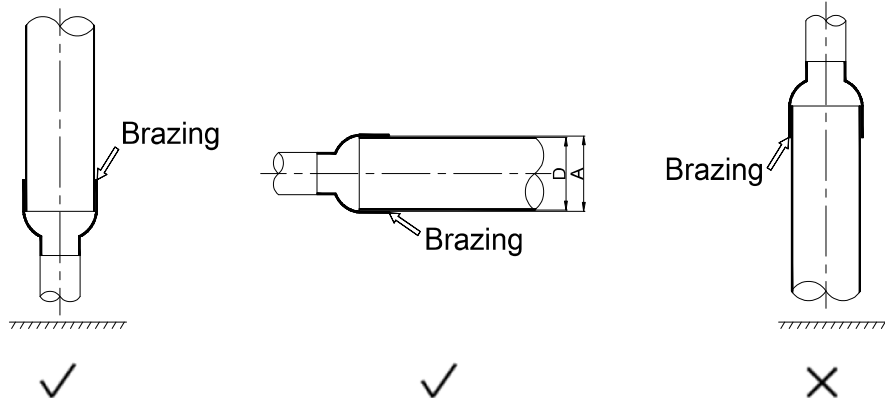

**Piping overlap during brazing**

Table 3-3.5 specifies the minimum permissible piping overlap and the range of permissible gap sizes for brazed joints on piping of different diameters. Refer also to Figure 3-3.8.

Figure 3-3.8: Piping overlap and gap for brazed joints

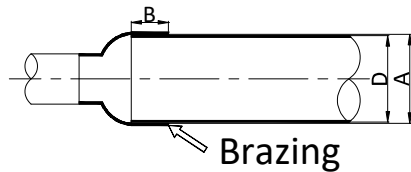

Legend	
A	Inner diameter of larger pipe
D	Outer diameter of smaller pipe
B	Inlaid depth (overlap)

Table 3-3.5: Piping overlap and gap for brazed joints<sup>1</sup>

D (mm)	Minimum permissible B (mm)	Permissible A – D (mm)
5 < D < 8	6	0.05 - 0.21
8 < D < 12	7	
12 < D < 16	8	0.05 - 0.27
16 < D < 25	10	
25 < D < 35	12	0.05 - 0.35
35 < D < 45	14	

Notes:

- 1. A, B, D refer to the dimensions shown in Figure 3-5.7.

**Filler**

- Use a copper/phosphorus brazing alloy (BCuP) filler that does not require flux.
- Do not use flux. Flux can cause corrosion of piping and can affect the performance of compressor oil.
- Do not use anti-oxidants when brazing. Residue can clog piping and damage components.

### 3.8 Pipe Flushing

#### 3.8.1 Purpose

To remove dust, other particles and moisture, which could cause compressor malfunction if not flushed out before the system is run, the refrigerant piping should be flushed using nitrogen. As described in Part 3, 3.3.1 “Installation procedure”, pipe flushing should be performed once the piping connections have been completed with the exception of the final connections to the hydronic box. That is, flushing should be performed once the outdoor unit have been connected but before the hydronic box is connected.

#### 3.8.2 Procedure

##### Notes for installers



##### Warning

Only use nitrogen for flushing. Using carbon dioxide risks leaving condensation in the piping. Oxygen, air, refrigerant, flammable gases and toxic gases must not be used for flushing. Use of such gases may result in fire or explosion.

##### Procedure

The liquid and gas sides can be flushed simultaneously; alternatively, one side can be flushed first and then Steps 1 to 6 repeated, for the other side. The flushing procedure is as follows:

1. Attach a pressure reducing valve to a nitrogen cylinder.
2. Connect the pressure reducing valve outlet to the inlet on the liquid (or gas) side of the outdoor unit.
3. Start to open the nitrogen cylinder valve and gradually increase the pressure to 0.5MPa.
4. Allow time for nitrogen to flow as far as the opening at hydronic box.
5. Flush the opening:
  - a) Using suitable material, such as a bag or cloth, press firmly against the opening at hydronic box.
  - b) When the pressure becomes too high to block with your hand, suddenly remove your hand allowing gas to rush out.
  - c) Repeatedly flush in this manner until no further dirt or moisture is emitted from the piping. Use a clean cloth to check for dirt or moisture being emitted. Seal the opening once it has been flushed.
6. Once flushing is complete, seal the opening to prevent dust and moisture from entering.

*Figure 3-3.9: Pipe flushing using nitrogen*

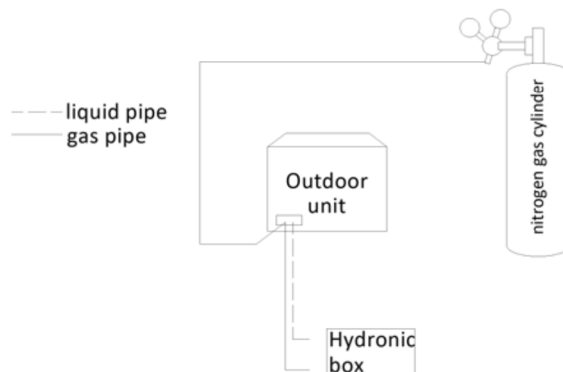

## S-Therm Yukon split series

### 3.9 Gastightness Test

#### 3.9.1 Purpose

To prevent faults caused by refrigerant leakage, a gastightness test should be performed before system commissioning.

#### 3.9.2 Procedure

##### Notes for installers



##### Warning

Only dry nitrogen should be used for gastightness testing. Oxygen, air, flammable gases and toxic gases must not be used for gastightness testing. Use of such gases may result in fire or explosion.

##### Procedure

The gastightness test procedure is as follows:

##### Step 1

- Once the piping system is complete and the hydronic box and outdoor unit have been connected, vacuum the piping to -0.1MPa.

##### Step 2

- Charge the piping with nitrogen at 0.3MPa and leave for at least 3 minutes to check large leakage, then 1.5MPa leave for at least 3 minutes to check small leakage, finally 4.3MPa leave for at least 24 hours to check micro leakage.
- After the test period of at least 24 hours, observe the pressure in the piping and assess whether or not the observed pressure indicates the presence of a leak. Allow for any change in ambient temperature over the test period by adjusting the reference pressure by 0.01MPa per 1°C of temperature difference. Adjusted reference pressure = Pressure at pressurization + (temperature at observation – temperature at pressurization) x 0.01MPa. Compare the observed pressure with the adjusted reference pressure. If they are the same, the piping has passed the gastightness test.
- If the observed pressure is lower than the adjusted reference pressure, the piping has failed the test. Refer to Part 3, [3.9.3 “Leak detection”](#). Once the leak has been found and fixed, the gastightness test should be repeated.

##### Step 3

- If not continuing straight to vacuum drying (see Part 3, [3.10 “Vacuum Drying”](#)) once the gastightness test is complete, reduce the system pressure to 0.5-0.8MPa and leave the system pressurized until ready to carry out the vacuum drying procedure.

Figure 3-3.10: Gastightness test

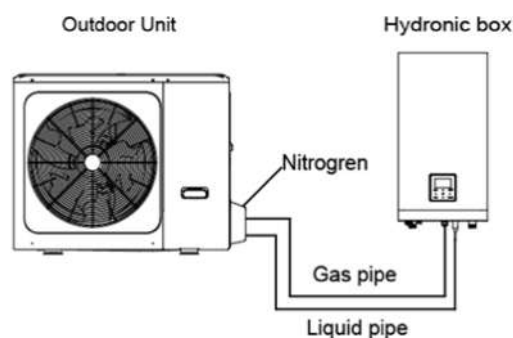

**3.9.3 Leak detection**
**Notes for installers**

The general methods for identifying the source of a leak are as follows:

1. Audio detection: relatively large leaks are audible.
2. Touch detection: place your hand at joints to feel for escaping gas.
3. Soapy water detection: small leaks can be detected by the formation of bubbles when soapy water is applied to a joint.

*Figure 3-3.11: Leak detection*

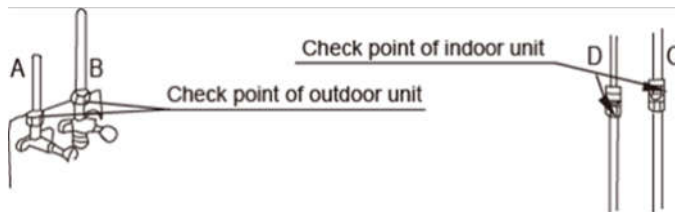

A: Liquid side stop valve  
 B: Gas side stop valve  
 C/D: Connect joints between outdoor unit and hydronic box

4. Refrigerant leak detection: for leaks that are difficult to detect, refrigerant leak detection may be used as follows:
  - a) Pressurize the piping with nitrogen at 0.3MPa.
  - b) Add refrigerant into the piping until the pressure reaches 0.5MPa.
  - c) Use a halogen refrigerant detector to find the leak.
  - d) If the leak source cannot be found, continuing charging with refrigerant to a pressure of 4.3 MPa and then search again.

**3.10 Vacuum Drying**
**3.10.1 Purpose**

Vacuum drying should be performed in order to remove moisture and non-condensable gases from the system. Removing moisture prevents ice formation and oxidization of copper piping or other internal components. The presence of ice particles in the system would cause abnormal operation, whilst particles of oxidized copper can cause compressor damage. The presence of non-condensable gases in the system would lead to pressure fluctuations and poor heat exchange performance.

Vacuum drying also provides additional leak detection (in addition to the gas tightness test).

### Notes for installers



During vacuum drying, a vacuum pump is used to lower the pressure in the piping to the extent that any moisture present evaporates. At 5mmHg (755mmHg below typical atmospheric pressure) the boiling point of water is 0°C. Therefore a vacuum pump capable of maintaining a pressure of -755mmHg or lower should be used. Using a vacuum pump with a discharge in excess of 4L/s and a precision level of 0.02mmHg is recommended.

#### Caution

- Before performing vacuum drying, make sure that the outdoor unit stop valves are firmly closed.
- Once the vacuum drying is complete and the vacuum pump is stopped, the low pressure in the piping could suck vacuum pump lubricant into the air conditioning system. The same could happen if the vacuum pump stops unexpectedly during the vacuum drying procedure. Mixing of pump lubricant with compressor oil could cause compressor malfunction and a one-way valve should therefore be used to prevent vacuum pump lubricant seeping into the piping system.

#### Procedure

The vacuum drying procedure is as follows:

##### Step 1

- Connect the blue (low pressure side) hose of a pressure gauge to the outdoor unit gas pipe stop valve, the red (high pressure side) hose to the outdoor unit liquid pipe stop valve and the yellow hose to the vacuum pump.

##### Step 2

- Start the vacuum pump and then open the pressure gauge valves to start vacuum the system.
- After 30 minutes, close the pressure gauge valves.
- After a further 5 to 10 minutes check the pressure gauge. If the gauge has returned to zero, check for leakages in the refrigerant piping.

##### Step 3

- Re-open the pressure gauge valves and continue vacuum drying for at least 2 hours and until a pressure difference of 756mmHg or more has been achieved. Once the pressure difference of at least 756mmHg has been achieved, continue vacuum drying for 2 hours.

##### Step 4

- Close the pressure gauge valves and then stop the vacuum pump.
- After 1 hour, check the pressure gauge. If the pressure in the piping has not increased, the procedure is finished. If the pressure has increased, check for leakages.
- After vacuum drying, **keep the blue and red hoses connected to the pressure gauge and to the outdoor unit stop valves**, in preparation for refrigerant charging (see Part 3, 3.11 “Charging Refrigerant”).

Figure 3-3.12: Pressure gauge



## 3.11 Charging Refrigerant

### 3.11.1 Calculating additional refrigerant charge

Calculate the added refrigerant according to the diameter and the length of the liquid side pipe of the outdoor unit/indoor unit connection. If the length of the liquid side pipe is less than 15 meters it is no need to add more refrigerant, so calculating the added refrigerant the length of the liquid side pipe must subtract 15 meters.

Table 3-3.6: Additional refrigerant charge

Refrigerant to be added	Model	L(m)	
		≤15m	>15m
Total additional refrigerant	4/6kW	0g	(L-15)*20g
	8/10/12/14/16kW	0g	(L-15)*38g

### 3.11.2 Adding refrigerant

#### Notes for installers



#### Caution

- Only charge refrigerant after performing a gas tightness test and vacuum drying.
- Never charge more refrigerant than required as doing so can lead to liquid hammering.
- Only use refrigerant R32 - charging with an unsuitable substance may cause explosions or accidents.
- Use tools and equipment designed for use with R32 to ensure required pressure resistance and to prevent foreign materials from entering the system.
- Refrigerant must be treated in accordance with applicable legislation.
- Always use protective gloves and protect your eyes when charging refrigerant.
- Open refrigerant containers slowly.
- Keep the site well ventilated, no ignition source and fire extinguisher in hand for R32 is a flammable refrigerant.

#### Procedure

The procedure for adding refrigerant is as follows:

#### Step 1

- Calculate additional refrigerant charge R (kg) (see Part 3, [3.11.1](#) "Calculating Additional Refrigerant Charge")

#### Step 2

- Place a tank of R32 refrigerant on a weighing scale. Turn the tank upside down to ensure refrigerant is charged in a liquid state.
- After vacuum drying (see Part 3, [3.10](#) "Vacuum Drying"), the blue and red pressure gauge hoses should still be connected to the pressure gauge and to the outdoor unit stop valves.
- Connect the yellow hose from the pressure gauge to the R32 refrigerant tank.

#### Step 3

- Open the valve where the yellow hose meets the pressure gauge, and open the refrigerant tank slightly to let the refrigerant eliminate the air. Caution: open the tank slowly to avoid freezing your hand.
- Set the weighing scale to zero.

Box continued on next page ...

... box continued from previous page

**Step 4**

- Open the three valves on the pressure gauge to begin charging refrigerant.
- When the amount charged reaches R (kg), close the three valves. If the amount charged has not reached R (kg) but no additional refrigerant can be charged, close the three valves on the pressure gauge, run the outdoor unit in cooling mode, and then open the yellow and blue valves. Continue charging until the full R (kg) of refrigerant has been charged, then close the yellow and blue valves. Note: Before running the system, be sure to complete all test run checks as listed in Part 3, 8.15 "TEST RUN" and be sure to open stop valves as running the system with the stop valves closed would damage the compressor.

Figure 3-3.13: Charging refrigerant

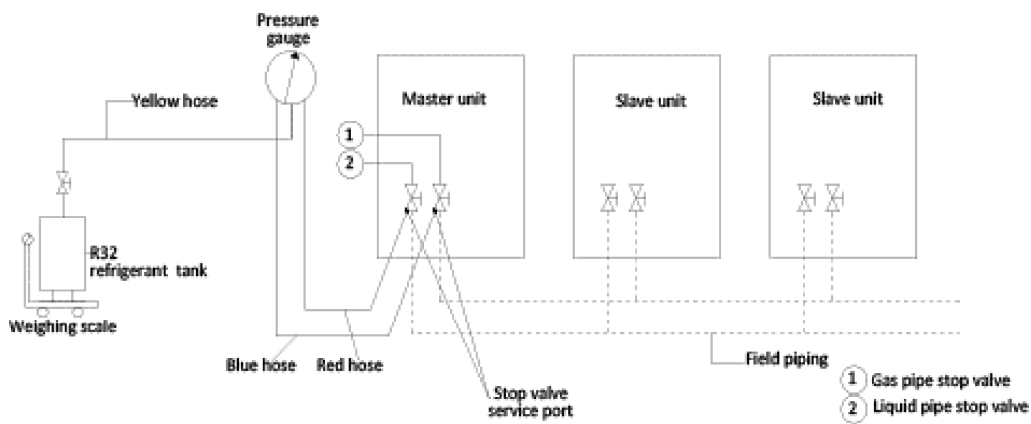

Pressure gauge

## 4 Water Pipework

### 4.1 Water Circuit Checks

Hydronic boxes are equipped with a water inlet and outlet for connection to a water circuit. S-Therm Yukon units should only be connected to closed water circuits. Connection to an open water circuit would lead to excessive corrosion of the water piping. Only materials complying with all applicable legislation should be used.

Before continuing installation of the unit, check the following:

- The maximum water pressure  $\leq 3$  bar.
- The maximum water temperature  $\leq 70^{\circ}\text{C}$  according to safety device setting.
- Always use materials that are compatible with the water used in the system and with the materials used in the unit.
- Ensure that components installed in the field piping can withstand the water pressure and temperature.
- Drain taps must be provided at all low points of the system to permit complete drainage of the circuit during maintenance.
- Air vents must be provided at all high points of the system. The vents should be located at points that are easily accessible for service. An automatic air purge is provided inside the unit. Check that this air purge valve is not tightened so that automatic release of air in the water circuit is possible.

### 4.2 Water volume and sizing expansion vessels

The units are equipped with an expansion vessel of 8L that has a default pre-pressure of 1.5 bar. To assure proper operation of the unit, the pre-pressure of the expansion vessel might need to be adjusted.

- Check that the total water volume in the installation, excluding the internal water volume of the unit, is at least 40L.
- Expansion vessel volume must fit the total water system volume.
- To size the expansion for the heating and cooling circuit.

The expansion vessel volume can follow the figure below:

*Figure 3-4.1: Expansion vessel volume*

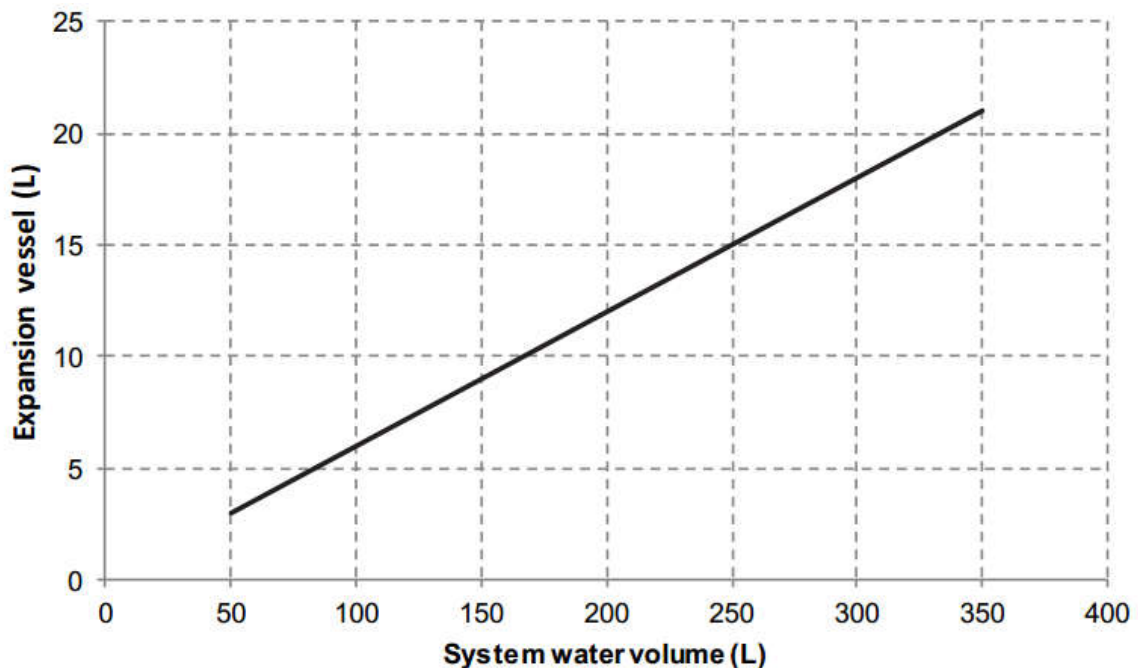

Notes:

- In most applications this minimum water volume will be satisfactory.
- In critical processes or in rooms with a high heat load though, extra water might be required.
- When circulation in each space heating loop is controlled by remotely controlled valves, it is important that this

## S-Therm Yukon split series

minimum water volume is kept even if all the valves are closed.

### 4.3 Water Circuit Connection

Water connections must be made correctly in accordance with the labels on the hydronic box, with respect to the water inlet and water outlet. If air, moisture or dust gets in the water circuit, problems may occur. Therefore, always take into account the following when connecting the water circuit:

- Use clean pipes only.
- Hold the pipe end downwards when removing burrs
- Cover the pipe end when inserting it through a wall to prevent dust and dirt entering.
- Use a good thread sealant for sealing the connections. The sealing must be able to withstand the pressures and temperatures of the system.
- When using non-copper metallic piping, be sure to insulate the two kinds of materials from each other to prevent galvanic corrosion.
- For copper is a soft material, use appropriate tools for connecting the water circuit. Inappropriate tools will cause damage to the pipes
- 

### 4.4 Water Circuit Anti-freeze Protection

Ice formation can cause damage to the hydronic system. All internal hydronic parts are insulated to reduce heat loss. Insulation must also be added to the field piping.

- The software contains special functions using the heat pump to protect the entire system against freezing. When the temperature of the water flow in the system drops to a certain value, the unit will heat the water, either using the heat pump, the electric heating tap, or the backup heater. The freeze protection function will turn off only when the temperature increases to a certain value.
- In event of a power failure, the above features would not protect the unit from freezing. Since a power failure could happen when the unit is unattended, the supplier recommends use anti-freeze fluid to the water system.
- Depending on the expected lowest outdoor temperature, make sure the water system is filled with a concentration of glycol as mentioned in the table below. When glycol is added to the system, the performance of the unit will be affected. The correction factor of the unit capacity, flow rate and pressure drop of the system is listed in the table 3-4.1 and 3-4.2
- 

Table 3-4.1: Ethylene Glycol

Concentration of ethylene glycol (%)	Modification coefficient				Minimum outdoor temperature (°C)
	Cooling capacity modification	Power input modification	Water resistance	Water flow modification	
0	1.000	1.000	1.000	1.000	0
10	0.984	0.998	1.118	1.019	-5
20	0.973	0.995	1.268	1.051	-15
30	0.965	0.992	1.482	1.092	-25

Table 3-4.2: Propylene Glycol

Concentration of propylene glycol (%)	Modification coefficient				Minimum outdoor temperature (°C)
	Cooling capacity modification	Power input modification	Water resistance	Water flow modification	
0	1.000	1.000	1.000	1.000	0
10	0.976	0.996	1.071	1.000	-4
20	0.961	0.992	1.189	1.016	-12

30	0.948	0.988	1.380	1.034	-20
----	-------	-------	-------	-------	-----

Uninhibited glycol will turn acidic under the influence of oxygen. This process is accelerated by presence of copper and at higher temperatures. The acidic uninhibited glycol attacks metal surfaces and forms galvanic corrosion cells that cause severe damage to the system. It is of extreme importance:

- That the water treatment is correctly executed by a qualified water specialist.
- That a glycol with corrosion inhibitors is selected to counteract acids formed by the oxidation of glycols.
- That in case of an installation with a domestic hot water tank, only the use of propylene glycol is allowed. In other installations the use of ethylene glycol is fine.
- That no automotive glycol is used because their corrosion inhibitors have a limited lifetime and contain silicates that can foul or plug the system;
- That galvanized piping is not used in glycol systems since it may lead to the precipitation of certain elements in the glycol's corrosion inhibitor;
- To ensure that the glycol is compatible with the materials used in the system.

#### 4.5 Water Flow Switch

Water may enter into the flow switch and cannot be drained out and may freeze when the temperature is low enough. The flow switch should be removed and dried, then can be reinstalled in the unit.

- Counterclockwise rotation, remove the water flow switch.
- Drying the water flow switch completely.

Figure 3-4.2: Water flow switch

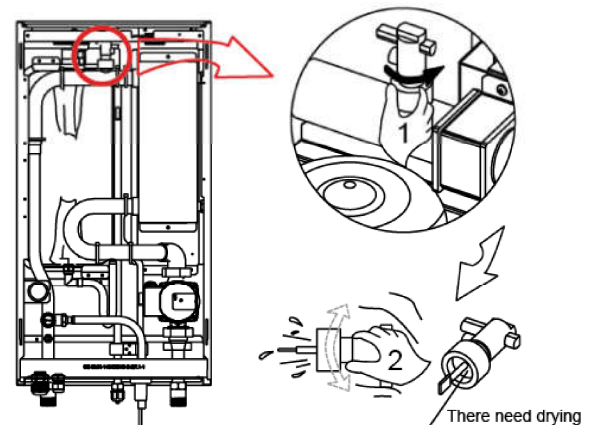

#### 4.6 Adding Water

- Connect the water supply to the fill valve and open the valve.
- Make sure the automatic air purge valve is open (at least 2 turns).
- Fill with water until the manometer indicates a pressure of approximately 2.0 bars. Remove air in the circuit as much as possible using the air purge valve. Air in the water circuit could lead to malfunction of the backup electric heater.

#### 4.7 Water Piping Insulation

The complete water circuit including all piping, water piping must be insulated to prevent condensation during cooling operation and reduction of the heating and cooling capacity as well as prevention of freezing of the outside water piping during winter. The insulation material should at least of B1 fire resistance rating and complies with all applicable legislation. The thickness of the sealing materials must be at least 13mm with thermal conductivity 0.039W/mK in order to prevent freezing on the outside water piping. If the outdoor ambient temperature is higher than 30°C and the humidity is higher than RH 80%, the thickness of the sealing materials should be at least 20mm in order to avoid condensation on the surface of the seal.

## 5 Electrical Wiring

### 5.1 General

#### Notes for installers



##### Caution

- All installation and wiring must be carried out by competent and suitably qualified, certified and accredited professionals and in accordance with all applicable legislation.
- Electrical systems should be grounded in accordance with all applicable legislation.
- Overcurrent circuit breakers and residual-current circuit breakers (ground fault circuit interrupters) should be used in accordance with all applicable legislation.
- Wiring patterns shown in this data book are general connection guides only and are not intended for, or to include all details for, any specific installation.
- The water piping, power wiring and communication wiring are typically run in parallel. However the communication wiring should not be bound together with power wiring. To prevent signal interference, the power wiring and communication wiring should not be run in the same conduit. If the power supply is less than 10A, a separation of at least 300mm between power wiring and communication wiring conduits should be maintained; if the power supply is in the range 10A to 50A then a separation of at least 500mm should be maintained.

### 5.2 Precautions

- Fix cables so that cables do not make contact with the pipes (especially on the high pressure side).
- Secure the electrical wiring with cable ties so that it does not come in contact with the piping, particularly on the high-pressure side.
- Make sure no external pressure is applied to the terminal connectors.
- When installing the ground fault circuit interrupter make sure that it is compatible with the inverter (resistant to high frequency electrical noise) to avoid unnecessary opening of the ground fault circuit interrupter
- This unit is equipped with an inverter. Installing a phase advancing capacitor not only reduce the power factor improvement effect, but also may cause abnormal heating of the capacitor due to high frequency waves. Never install a phase advancing capacitor as it could lead to an accident.

### 5.3 Guidance

- Most field wiring on the unit is to be made on the terminal block inside the switch box. To gain access to the terminal block, remove the switch box service panel.
- Fix all cables using cable ties.
- A dedicated power circuit is required for the backup electric heater.
- Installation equipped with a domestic hot water tank (field supplied) requires a dedicated power circuit for the immersion heater.

Secure the wiring in the order shown below:

- Lay out the electrical wiring so that the front cover does not rise up when doing wiring work and attach the front cover securely.
- Follow the electric wiring diagrams for electrical wiring works. Refer to Figure 2-4:1 to Figure 2-4:5 in part 2, 4 “Wiring Diagram”.
- Install the wires and fix the cover firmly so that the cover may be fit in properly.

5.4 Wiring Overview

Figure 3-5.1: Wiring overview

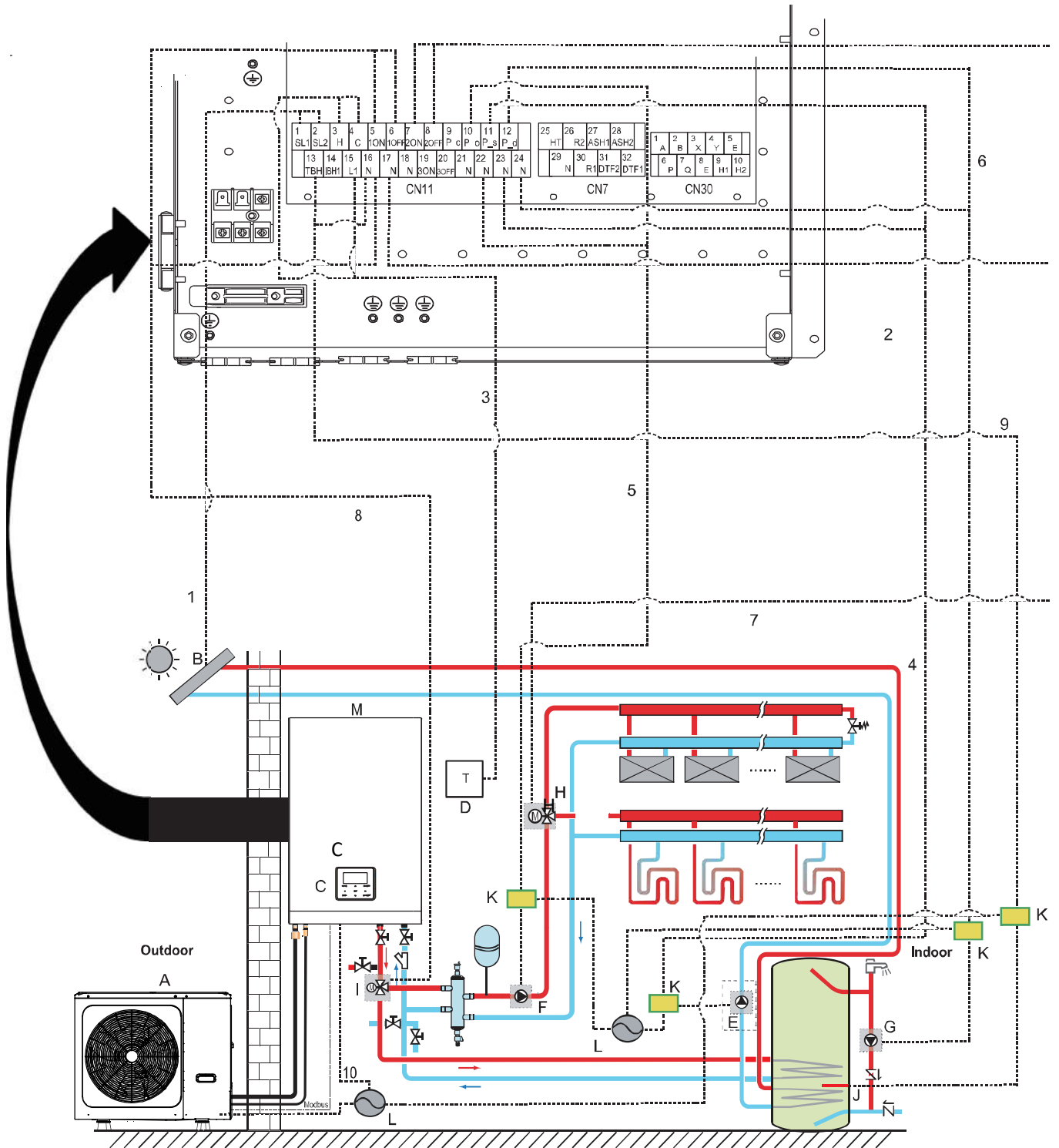

Legend			
A	Outdoor unit	H	SV2: 3-way valve (field supply)
B	Solar energy kit (field supplied)	I	SV1: 3-way valve for domestic hot water tank (field supply)
C	User interface	J	Booster heater
D	High voltage room thermostat (field supplied)	K	Contactors
E	P_s: Solar pump (field supply)	L	Power supply
F	P_o: Outside circulation pump (field supply)	M	Indoor unit
G	P_d: DHW pump (field supply)		

## S-Therm Yukon split series

Table 3-5.1: Wiring requirements



Item	Description	Current	Required number of conductors	Maximum running current
1	Solar energy kit signal cable	AC	2	200mA
2	User interface cable	AC	5	200mA
3	Room thermostat cable	AC	2	200mA <sup>1</sup>
4	Solar pump control cable	AC	2	200mA <sup>1</sup>
5	Outside circulation pump control cable	AC	2	200mA <sup>1</sup>
6	DHW pump control cable	AC	2	200mA <sup>1</sup>
7	SV2: 3-way valve control cable	AC	3	200mA <sup>1</sup>
8	SV1: 3-way valve control cable	AC	3	200mA <sup>1</sup>
9	Booster heater control cable	AC	2	200mA <sup>1</sup>
10	Power supply cable for indoor unit	AC	2+GND	0.4A

Notes:

5. Minimum cable section AWG18 (0.75 mm<sup>2</sup>)
6. The thermistor cable are delivered with the unit: if the current of the load is large, an AC contactor is needed.

## 6 DIP Switch Settings

DIP switch S1,S2 is located on the hydraulic module main control board and allows configuration of additional heating source thermistor installation, the second inner backup heater installation, etc. Refer to Table 3-6.1 and to the S-Therm Yukon Service Manual, Part 4, 2.2 "Main PCB for Hydronic System".

Switch		ON=1	OFF=0
<b>S1</b> ON OFF 	1/2	0/0=IBH(One-step control) 0/1=IBH(Two-step control) 1/1=IBH(Three-stage control)	
	3/4	0/0=Without IBH and AHS 1/0=With IBH 0/1=With AHS for heating mode 1/1=With AHS for heating mode and DHW mode	
<b>S2</b> ON OFF 	1	Start pump after 24 hours will be invalid	Start pump after 24 hours will be valid
	2	without TBH	with TBH
	3/4	00=pump 1 01=pump 2 10=pump 3 11=pump 4	
<b>S4</b> ON OFF 	1	Reserved	Reserved
	2	IBH for DHW=valid	IBH for DHW=invalid
	3/4	Reserved	

## 7 Internal Circulation Pump

The pump is controlled via a digital low-voltage pulse-width modulation signal which means that the speed of rotation depends on the input signal. The speed changes as a function of the input profile. The relationship between external static pressure and water flow rate is described in Part 2, 7 "Hydronic Performance".

Figure 3-7.1: Internal circulator pump

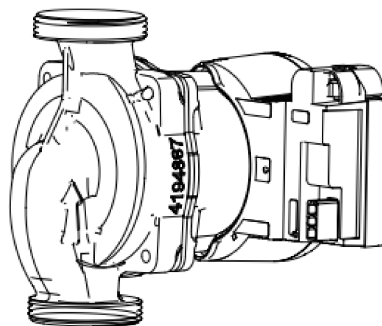

# S-Therm Yukon split series

## 8 User Interface Field Settings

### 8.1 Introduction

During installation, the M thermal settings and parameters should be configured by the installer to suit the installation configuration, climate conditions and end-user preferences. The relevant settings are accessible and programmable through the **FOR SERVICEMAN** menu on the M thermal user interface. The user interface menus and settings can be navigated using the user interface’s touch-sensitive keys, as detailed in Table 3-8.1.

Figure 3-8.1: User interface

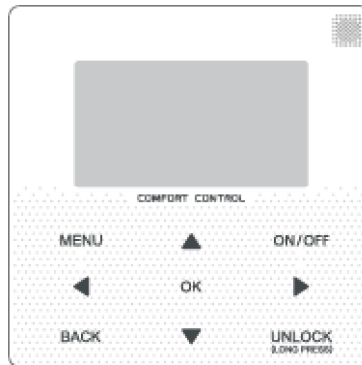
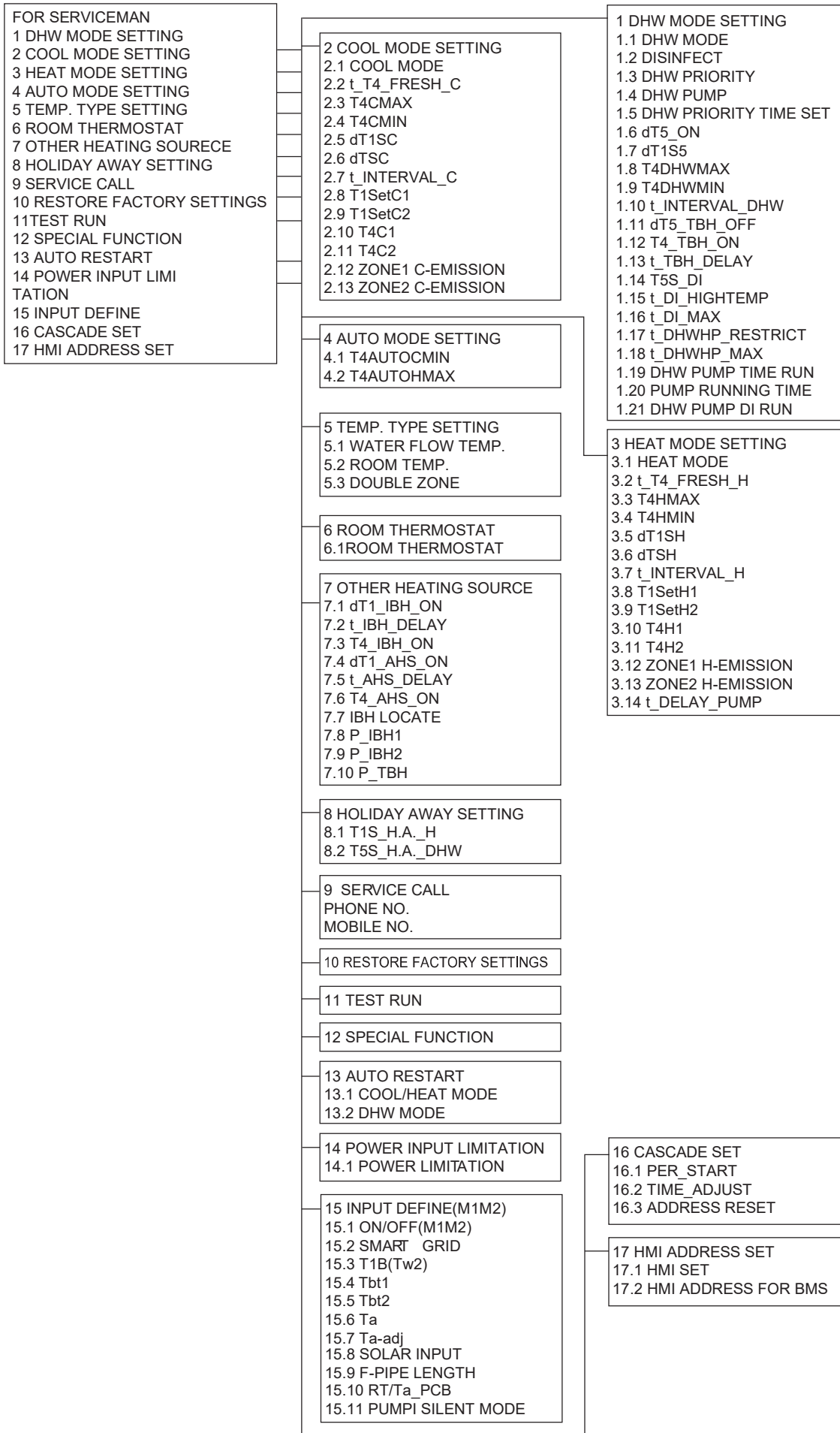

Table 3-8.1: User interface keys

Keys	Function
<b>MENU</b>	<ul style="list-style-type: none"> <li>Go to the menu structure</li> </ul>
◀ ▶ ▼ ▲	<ul style="list-style-type: none"> <li>Navigate the cursor on the display</li> <li>Navigate in the menu structure</li> <li>Adjust settings</li> </ul>
<b>ON/OFF</b>	<ul style="list-style-type: none"> <li>Turn on/off the space heating/cooling operation or DHW mode</li> <li>Turn on/off functions in the menu structure</li> </ul>
<b>BACK</b>	<ul style="list-style-type: none"> <li>Come back to the up level</li> </ul>
<b>UNLOCK</b>	<ul style="list-style-type: none"> <li>Long press for unlock/lock the controller</li> <li>Unlock /lock some functions such as “DHW temperature adjusting”</li> </ul>
<b>OK</b>	<ul style="list-style-type: none"> <li>Go to the next step when programming a schedule in the menu structure and confirm a selection to enter in the submenu of the menu structure.</li> </ul>

**8.2 Menu Structure**

## S-Therm Yukon split series

### 8.3 FOR SERVICEMAN Menu

**FOR SERVICEMAN** allows installers to input the system configuration and set the system parameters. To enter **FOR SERVICEMAN**, go to **MENU > FOR SERVICEMAN**.

Enter the password, using ◀ ▶ to navigate between digits and using ▼ ▲ to adjust the numerical values, and then press **OK**. The password is 234. Refer to Figure 3-8.2

Then the following pages will be displayed after putting the password. Refer to Figure 3-8.3

Figure 3-8.2: FOR SERVICEMAN password screen

FOR SERVICEMAN	
Please input the password:	
0 0 0	
OK ENTER	ADJUST

Figure 3-8.3: FOR SERVICEMAN menu

FOR SERVICEMAN 1/3	FOR SERVICEMAN 2/3
1. DHW MODE SETTING	7. OTHER HEATING SOURCE
2. COOL MODE SETTING	8. HOLIDAY AWAY MODE SET
3. HEAT MODE SETTING	9. SERVICE CALL SETTING
4. AUTO MODE SETTING	10. RESTORE FACTORY SETTINGS
5. TEMP.TYPE SETTING	11. TEST RUN
6. ROOM THERMOSTAT	12. SPECIAL FUNCTION
OK ENTER	OK ENTER

FOR SERVICEMAN 3/3
13. AUTO RESTART
14. POWER INPUT LIMITATION
15. INPUT DEFINE
16. CASCADE SET
17. HMI ADDRESS SET
OK ENTER

### 8.4 DHW MODE SETTING Menu

#### 8.4.1 DHW MODE SETTING menu overview

**MENU > FOR SERVICEMAN > DHW MODE SETTING**

Figure 3-8.4: DHW MODE SETTING menu

1 DHW MODE SETTING 1/5	1 DHW MODE SETTING 2/5
1.1 DHW MODE YES	1.6 dT5_ON 5 °C
1.2 DISINFECT YES	1.7 dT1S5 10 °C
1.3 DHW PRIORITY YES	1.8 T4DHWMAX 43 °C
1.4 DHW PUMP YES	1.9 T4DHWMIN -10 °C
1.5 DHW PRIORITY TIME SET NON	1.10 t_INTERVAL_DHW 5 MIN
ADJUST	ADJUST

1 DHW MODE SETTING 3/5
1.11 dT5_TBH_OFF 5 °C
1.12 T4_TBH_ON 5 °C
1.13 t_TBH_DELAY 30 MIN
1.14 T5S_DI 65 °C
1.15 t_DI HIGHTEMP. 15MIN
ADJUST

1 DHW MODE SETTING	4/5
1.16 t_DI_MAX	210 MIN
1.17 t_DHWHP_RESTRICT	30 MIN
1.18 t_DHWHP_MAX	120 MIN
1.19 DHWPUMP TIME RUN	YES
1.20 PUMP RUNNING TIME	5 MIN
ADJUST	

1 DHW MODE SETTING	5/5
1.21 DHW PUMP DI RUN	NON
ADJUST	

In **DHW MODE SETTING** the following parameters should be set.

**DHW MODE** enables or disables DHW mode. For installations with DHW tanks, select **YES** to enable DHW mode. For installations without DHW tanks, select **NON** to disable DHW mode.

**DISINFECT** sets whether or not the disinfection operation is performed.

**DHW PRIORITY** sets whether domestic hot water heating or space heating/cooling takes priority. If **NON** is selected in the **DHW PRIORITY** mode, when it is available and the space heating/cooling is **OFF**, the heat pump will heat the water as required. If space heating/cooling is **ON**, the water will be heated as required when the immersion heater is unavailable. Only when the space heating/cooling is **OFF** will the heat pump operate to heat domestic water.

**DHW PUMP** sets whether or not the DHW pump is controlled by the S-Therm Yukon unit. If the DHW pump is to be controlled by the S-Therm Yukon, select **YES**. If the DHW pump is not to be controlled by the S-Therm Yukon unit, select **NON**.

**DHW PUMP PRIORITY TIME SET** set the operation time of DHW during **DHW PRIORITY** mode.

**dT5\_ON** sets the temperature difference between the DHW set temperature (T5S) and the DHW tank water temperature (T5) above which the heat pump providing heated water to the DHW tank. When  $T5S - T5 \geq dT5\_ON$  the heat pump providing heated water to the DHW tank.

Note: When the heat pump's leaving water temperature is above the DHW mode leaving water temperature operating limit (T5stop), the heat pump does not provide heated water to the DHW tank. The DHW mode leaving water temperature operating limit is related to ambient temperature as shown in Figure 2-6.3 in Part 2, 6 "Operating Limits".

**dT1S5** sets the heat pump's leaving water set temperature (T1S) relative to DHW tank water temperature (T5). For DHW mode, the user sets the DHW set temperature (T5S) on the main screen and cannot manually set T1S. T1S is set as  $T1S = T5 + dT1S5$ .

Figure 3-8.5: dT5\_ON

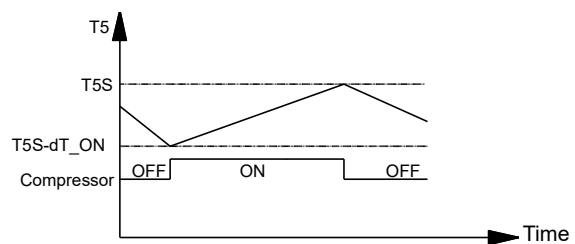

Abbreviations:  
T5: DHW tank water temperature  
T5S: DHW set temperature

Figure 3-8.6: DHW mode operation

## S-Therm Yukon split series

Figure 3-8.6 illustrates the operation of the heat pump and immersion heater(optional) in DHW mode. If the DHW tank water temperature ( $T5$ ) is less than the minimum of the DHW set temperature ( $T5S$ ) and the heat pump leaving water temperature operating limit ( $T5stop$ ) (refer to Figure 2-6.3 in Part 2, 6 “Operating Limits”) less  $dT5\_ON$ , the heat pump starts providing heated water to the DHW tank. After  $t\_TBH\_delay$  minutes have elapsed, the immersion heater is turned on. If  $T5$  reaches  $T5stop$ , the heat pump stops but the immersion heater continues running until  $T5$  has reached  $T5S + dT5\_TBH\_OFF$

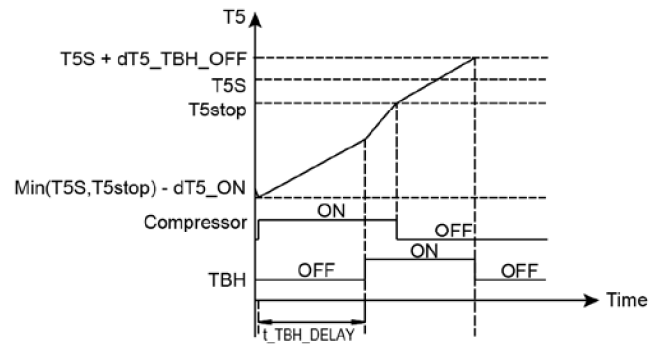

Abbreviations:  
 $T5$ : DHW tank water temperature  
 $T5S$ : DHW set temperature  
 $T5stop$ : DHW mode leaving water temperature operating limit  
 $TBH$ : Immersion heater in DHW tank

**T4DHWMAX** sets the ambient temperature above which the heat pump will not operate in DHW mode. The highest value that **T4DHWMAX** can take is 43°C, which is the DHW mode upper ambient temperature operating limit of the heat pump.

**T4DHWMIN** sets the ambient temperature below which the heat pump will not operate in DHW mode. The lowest value that **T4DHWMIN** can take is -25°C, which is the DHW mode lower ambient temperature operating limit of the heat pump.

**t\_INTERVAL\_DHW** sets the DHW mode compressor re-start delay. When the compressor stops running, it will not re-start until at least **t\_INTERVAL\_DHW** minutes have elapsed.

**dT5\_TBH\_OFF** sets the temperature difference between the DHW set temperature ( $T5S$ ) and the DHW tank water temperature ( $T5$ ) below which the immersion is not used. When  $T5 > \text{Min}(T5Stop+dT5\_TBH\_OFF, 65^\circ\text{C})$ , the immersion heater is off.

**T4\_TBH\_ON** sets the ambient temperature above which the immersion heater will not be used.

**t\_TBH\_DELAY** sets the delay between the compressor starting and the immersion heater being turned on.

**T5S\_DI** sets the DHW tank disinfection operation target temperature. Caution: during the disinfection operation (duration: **t\_DI\_MAX**) the domestic hot water temperature at the hot water taps will at times be equal to the value set for **T5S\_DI**.

**t\_DI\_HIGHTEMP** sets that length of time that the DHW tank disinfection operation target temperature is maintained.

**t\_DI\_MAX** sets the total duration of the DHW tank disinfect operation.

**t\_DHWHP\_RESTRICT** sets the maximum length of time that the heat pump will run in space heating or space cooling modes before switching to DHW mode, if a requirement for DHW mode exists. When running in space heating mode or space cooling mode, the heat pump becomes available for DHW mode either as soon as

Figure 3-8.7:  $T4DHWMAX$  and  $T4DHWMIN$

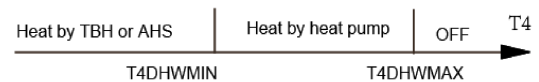

Abbreviations:  
 $HP$ : Heat pump  
 $TBH$ : DWH tank immersion heater  
 $AHS$ : Additional heating source

Figure 3-8.8: DHW tank disinfection

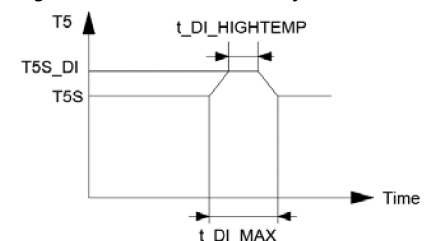

Abbreviations:  
 $T5$ : DHW tank water temperature  
 $T5S$ : DHW set temperature

the space heating/cooling set temperatures have been reached (refer to Part 3, [8.5](#) “COOL MODE SETTING Menu” and Part 3, [8.6](#) “HEAT MODE SETTING Menu”) or after **t\_DHWHP\_MAX** minutes have elapsed.

**t\_DHWHP\_MAX** sets the maximum length of time that the heat pump will run in DWH mode before switching to space heating mode or space cooling mode if a requirement for space heating/cooling modes exists. When running in DWH mode, the heat pump becomes available for space heating/cooling either as soon as the DHW tank water temperature (T5) reaches the DHW set temperature (T5S) or after **t\_DHWHP\_MAX** minutes have elapsed.

Figure 3-8.9 illustrates the effects of **t\_DHWHP\_MAX** and **t\_DHWHP\_RESTRICT** when **DHW PRIORITY** is enabled. The heat pump initially runs in DWH mode. After **t\_DHWHP\_MAX** minutes, T5 has not reached

Figure 3-8.9: Operation in DHW PRIORITY

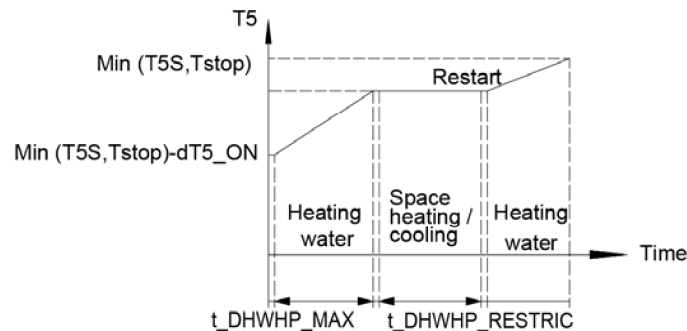

Abbreviations:

T5: DHW tank water temperature

T5S: DHW set temperature

T5stop: DHW mode leaving water temperature operating limit

**DHW PUMP TIME RUN** sets whether or not the user is able to set the DHW pump (field supply) in DHW mode. For installations with a DHW pump, select ON so that the user is able to set pump start times.

**PUMP RUNNING TIME** sets the length of time the pump runs for at each of the user-specified start times on the **DHW PUMP** tab on the **DOMESTIC HOT WATER (DHW)** menu, if **TIMER RUNNING** is enabled.

**DHW PUMP DI RUN** sets whether or not the DHW pump (field supply) operates during the disinfection mode.

## 8.5 COOL MODE SETTING Menu

MENU > FOR SERVICEMAN > COOL MODE SETTING

Figure 3-8.10: COOL MODE SETTING menu

2 COOL MODE SETTING	1/3	2 COOL MODE SETTING	2/3
2.1 COOL MODE	YES	2.6 dTSC	2°C
2.2 t_T4_FRESH_C	2.0HRS	2.7 t_INTERVAL_C	5MIN
2.3 T4CMAX	43°C	2.8 T1SetC1	10°C
2.4 T4CMIN	20°C	2.9 T1SetC2	16°C
2.5 dT1SC	5°C	2.10 T4C1	35°C
ADJUST		ADJUST	

2 COOL MODE SETTING	3/3
2.11 T4C2	25°C
2.12 ZONE1 C-EMISSION	FCU
2.13 ZONE2 C-EMISSION	FLH
ADJUST	

## S-Therm Yukon split series

In **COOL MODE SETTING** the following parameters should be set.

**COOL MODE** enables or disables cooling mode. For installations with space cooling terminals, select **YES** to enable cooling mode. For installations without space cooling terminals, select **NON** to disable cooling mode.

**t\_T4\_FRESH\_C** sets the refresh time of cooling mode climate temperature curve.

**T4CMAX** sets the ambient temperature above which the heat pump will operate in cooling mode with lowest compressor frequency. The highest value that **T4CMAX** can take is 46°C, which is the cooling mode upper ambient temperature operating limit of the heat pump. Refer to Figure 3-8.11.

Figure 3-8.11: T4CMAX, T4CMIN

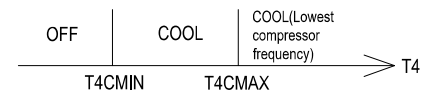

Abbreviations:

T4: Outdoor ambient temperature

**T4CMIN** sets the ambient temperature below which the heat pump will not operate in cooling mode. The lowest value that **T4CMIN** can take is -5°C, which is the cooling mode lower ambient temperature operating limit of the heat pump. Refer to Figure 3-8.12.

**dT1SC** sets the minimum temperature difference between the heat pump leaving water temperature (T1) and the heat pump leaving water set temperature (T1S) at which the heat pump provides chilled water to the space cooling terminals. When  $T1 - T1S \geq dT1SC$  the heat pump provides chilled water to the space cooling terminals and when  $T1 \leq T1S$  the heat pump does not provide chilled water to the space cooling terminals.

Figure 3-8.12: dT1SC

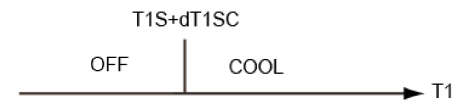

Abbreviations:

T1: Heat pump leaving water temperature

T1S: Heat pump leaving water set temperature

**dTSC** sets the temperature difference between the actual room temperature (Ta) and set room temperature (TS) above which the heat pump provides chilled water to the space cooling terminals. When  $Ta - TS \geq dTSC$  the heat pump provides chilled water to the space cooling terminals and when  $Ta \leq TS$  the heat pump does not provide chilled water to the space cooling terminals. Refer to Figure 3-8.18. **dTSC** is only applicable if **YES** is selected for **ROOM TEMP** in the **TEMP. TYPE SETTING** menu. Refer to Part 3, [8.8](#) "TEMP. TYPE SETTING Menu".

Figure 3-8.13: dTSC

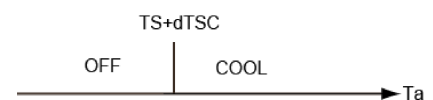

**t\_INTERVAL\_C** sets the cooling mode compressor re-start delay. When the compressor stops running, it will not re-start until at least **t\_INTERVAL\_C** minutes have elapsed.

**T1SetC1** sets the temperature 1 of automatic setting curve for cooling mode.

**T1SetC2** sets the temperature 2 of automatic setting curve for cooling mode.

**T4C1** sets the ambient temperature 1 of automatic setting curve for cooling mode.

**T4C2** sets the ambient temperature 2 of automatic setting curve for cooling mode.

**ZONE1 C-EMISSION** sets the emission type of zone1 for cooling mode.

**ZONE2 C-EMISSION** sets the emission type of zone2 for cooling mode.

**8.6 HEAT MODE SETTING Menu**
**MENU > FOR SERVICEMAN > HEAT MODE SETTING**
*Figure 3-8.14: HEAT MODE SETTING menu*

3 HEAT MODE SETTING 1/3	3 HEAT MODE SETTING 2/3	3 HEAT MODE SETTING 3/3
3.1 HEAT MODE <b>YES</b>	3.6 dTSH <b>2</b> °C	3.11 T4H2 <b>7</b> °C
3.2 t_T4_FRESH_H 2.0HRS	3.7 t_INTERVAL_H 5MIN	3.12 ZONE1 H-EMISSION RAD.
3.3 T4HMAX 16°C	3.8 T1SetH1 35°C	3.13 ZONE2 H-EMISSION FLH
3.4 T4HMIN -15°C	3.9 T1SetH2 28°C	3.14 t_DELAY_PUMP 2MIN
3.5 dT1SH 5°C	3.10 T4H1 -5°C	
⬇️ ADJUST ⬅️	⬇️ ADJUST ⬅️	⬇️ ADJUST ⬅️

In **HEAT MODE SETTING** the following parameters should be set.

**HEAT MODE** enables or disables heating mode.

**t\_T4\_FRESH\_H** sets the refresh time of heating model climate temperature curve.

**T4HMAX** sets the ambient temperature above which the heat pump will operate heating mode with lowest compressor frequency. The highest value that **T4HMAX** can take is 35°C, which is the heating mode upper ambient temperature operating limit of the heat pump. Refer to Figure 3-8.15.

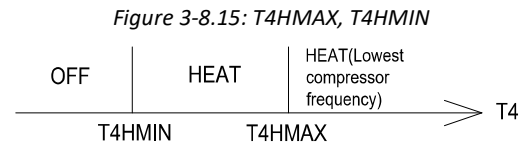

Abbreviations:  
T4: Outdoor ambient temperature

**T4HMIN** sets the ambient temperature below which the heat pump will not operate in heating mode. The lowest value that **T4HMIN** can take is -25°C, which is the heating mode lower ambient temperature operating limit of the heat pump. Refer to Figure 3-8.16.

**dT1SH** sets the temperature difference between the heat pump leaving water temperature (T1) and the heat pump leaving water set temperature (T1S) above which the heat pump provides heated water to the space heating terminals.

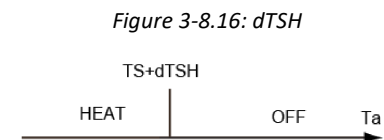

Note:  
Only when ROOM TEMP is enabled will this function be available

**dTSH** sets the temperature difference between the actual room temperature (Ta) and set room temperature (TS) above which the heat pump provides heated water to the space heating terminals. When  $TS - Ta \geq dTSH$  the heat pump provides heated water to the space heating terminals and when  $Ta \geq TS$  the heat pump does not provide heated water to the space heating terminals. Refer to Figure 3-8.23. **dTSH** is only relevant if **YES** is selected for **ROOM TEMP** in the **TEMP. TYPE SETTING** menu. Refer to Part 3, [8.8](#) “TEMP. TYPE SETTING Menu”.

**t\_INTERVAL\_H** sets the heating mode compressor re-start delay. When the compressor stops running, it will not re-start until at least **t\_INTERVAL\_H** minutes have elapsed.

**T1SetH1** sets the temperature 1 of automatic setting curve for heating mode.

**T1SetH2** sets the temperature 2 of automatic setting curve for heating mode.

## S-Therm Yukon split series

**T4H1** sets the ambient temperature 1 of automatic setting curve for heating mode.

**T4H2** sets the ambient temperature 2 of automatic setting curve for heating mode.

**ZONE1 H-EMISSION** sets the emission type for heating mode.

**ZONE2 H-EMISSION** sets the emission type for heating mode.

### 8.7 AUTO MODE SETTING Menu

**MENU > FOR SERVICEMAN > AUTO MODE SETTING**

In **AUTO MODE SETTING** the following parameters should be set.

**T4AUTOCMIN** sets the ambient temperature below which the heat pump will not provide chilled water for space cooling in auto mode. Refer to Figure 3-8.18.

**T4AUTOHMAX** sets the ambient temperature above which the heat pump will not provide heated water for space heating in auto mode. Refer to Figure 3-8.18.

Figure 3-8.17: AUTO MODE SETTING menu

4 AUTO. MODE SETTING	
4.1 T4AUTOCMIN	25°C
4.2 T4AUTOHMAX	17°C
⬇️ ADJUST	⬆️

Figure 3-8.18: T4AUTOCMAX, T4AUTOCMIN

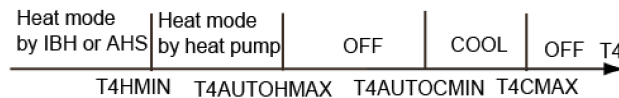

Abbreviations:

HP: Heat pump

AHS: Additional heating source

IBH: Backup electric heater

T4CMAX: The ambient temperature above which the heat pump will not operate in cooling mode.

T4HMIN: The ambient temperature below which the heat pump will not operate in heating mode.

### 8.8 TEMP. TYPE SETTING Menu

**MENU > FOR SERVICEMAN > TEMP. TYPE SETTING**

The **TEMP. TYPE SETTING** is used for selecting whether the water flow temperature or room temperature is used to control the ON/OFF of the heat pump.

When **ROOM TEMP.** is enabled, the target water flow temperature will be calculated from climate-related curves (refer to “9.1 Climate related curves”).

Figure 3-8.19: TEMP. TYPE SETTING menu

5 TEMP. TYPE SETTING	
5.1 WATER FLOW TEMP.	YES
5.2 ROOM TEMP.	NON
5.3 DOUBLE ZONE	NON
⬇️ ADJUST	⬆️

For installations without room thermostats, space heating and cooling modes can be controlled in one of two different ways:

- according to the M thermal leaving water temperature alone

- according to the room temperature detected by the S-Therm Yukon user interface's built-in temperature sensor alone

**WATER FLOW TEMP.** sets whether space heating/cooling modes are controlled according to the M thermal leaving water temperature. If **YES** is selected, the user is able to set the S-Therm Yukon unit's leaving water temperature set temperature on the user interface's main screen.

Figure 3-8.20: Only set WATER FLOW TEMP to YES

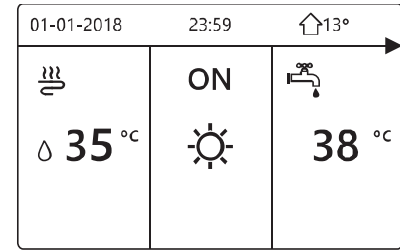

**ROOM TEMP.** sets whether space heating/cooling modes are controlled according to the room temperature detected by the temperature sensor in the S-Therm Yukon user interface. If **YES** is selected, the user is able to set the room temperature set temperature on the user interface's main screen, no matter what is the setting of **WATER FLOW TEMP.**

Figure 3-8.21: Only set ROOM TEMP to YES

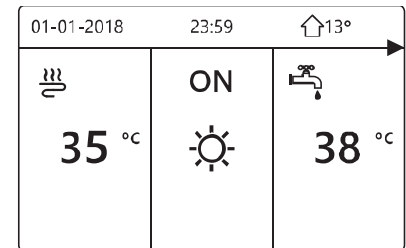

**DOUBLE ZONE** sets whether there are two zones.

If set **WATER FLOW TEMP.** and **ROOM TEMP.** to YES, meanwhile set **DOUBLE ZONE** to NON or YES, the following pages will be displayed. In this case, the setting value of zone 1 is T1S, the setting value of zone 2 is T1S2 (The corresponding T1S2 is calculated according to the climate related curves.)

Figure 3-8.22: Set WATER FLOW TEMP. and ROOM TEMP. to YES; Set DOUBLE ZONE to NON or YES

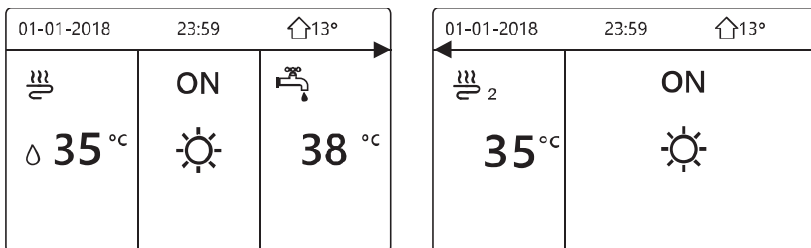

Homepage (zone 1)

Addition page (zone 2)  
(Double zone is effective)

If set **DOUBLE ZONE** to YES and set **ROOM TEMP.** to NON, meanwhile set **WATER FLOW TEMP.** to YES or NON, the following pages will be displayed. In this case, the setting value of zone 1 is T1S, the setting value of zone 2 is T1S2.

Figure 3-8.23: Set DOUBLE ZONE to YES and set ROOM TEMP. to NON; Set WATER FLOW TEMP. to YES or NON

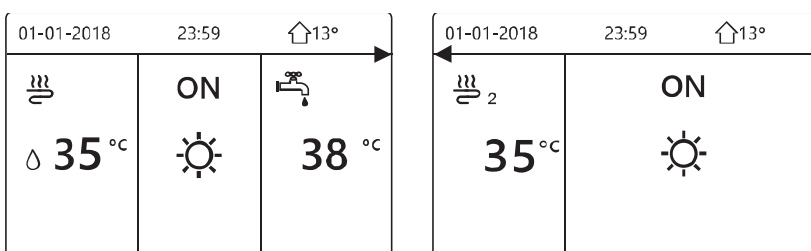

Homepage (zone 1)

Addition page (zone 2)

## S-Therm Yukon split series

If set DOUBLE ZONE and ROOM TEMP. to YES, meanwhile set WATER FLOW TEMP. to YES or NON, the following page will be displayed. In this case, the setting value of zone 1 is T1S, the setting value of zone 2 is T1S2. (The corresponding T1S2 is calculated according to the climate related curves.)

Figure 3-8.24: Set DOUBLE ZONE and ROOM TEMP. to YES; Set WATER FLOW TEMP. to YES or NON

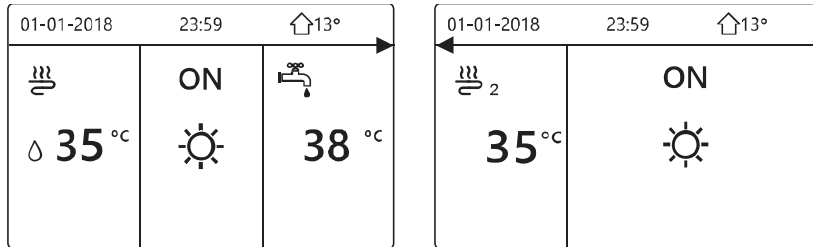

Homepage (zone 1)

Addition page (zone 2)  
(Double zone is effective)

## 8.9 ROOM THERMOSTAT Menu

### MENU > FOR SERVICEMAN > ROOM THERMOSTAT

As an alternative to controlling space heating/cooling modes according to the S-Therm Yukon unit's leaving water temperature and/or the room temperature detected by the temperature sensor in the S-Therm Yukon user interface, a separate room thermostat can be installed and used to control space heating/cooling modes.

Figure 3-8.25: ROOM THERMOSTAT menu

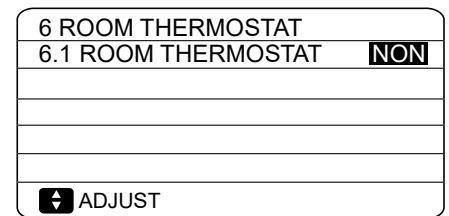

In **ROOM THERMOSTAT** the following parameters should be set.

**ROOM THERMOSTAT** sets whether or not room thermostats are installed. For installations with room thermostats, select **YES**. For installations without room thermostats, select **NON**.

ROOM THERMOSTAT = NON: No room thermostat.

ROOM THERMOSTAT = MODE SET: Room thermostat can control heating and cooling individually.

ROOM THERMOSTAT=ONE ZONE: Room thermostat provides the switch signal to unit.

ROOM THERMOSTAT=DOUBLE ZONE: Indoor unit is connected with two room thermostats.

## 8.10 OTHER HEATING SOURCE Menu

### 8.10.1 OTHER HEATING SOURCE menu overview

#### MENU > FOR SERVICEMAN > OTHER HEATING SOURCE

Figure 3-8.26: OTHER HEATING SOURCE menu

7 OTHER HEATING SOURCE 1/2		7 OTHER HEATING SOURCE 2/2	
7.1 dT1_IBH_ON	5°C	7.6 T4_AHS_ON	-5°C
7.2 t_IBH_DELAY	30MIN	7.7 IBH LOCATE	PIPE LOOP
7.3 T4_IBH_ON	-5°C	7.8 P_IBH1	0.0kW
7.4 dT1_AHS_ON	5°C	7.9 P_IBH2	0.0kW
7.5 t_AHS_DELAY	30MIN	7.10 P_TBH	2.0kW
ADJUST		ADJUST	

In **OTHER HEATING SOURCE** the following parameters should be set. Backup electric heater is optional.

**dT1\_IBH\_ON** sets the temperature difference between the heat pump's leaving water set temperature (T1S) and the heat pump's leaving water temperature (T1) above which the backup electric heater heating element(s) are on. When  $T1S - T1 \geq dT1\_IBH\_ON$  the backup electric heater is on (on models where the backup electric heater has a simple on/off control function).

**t\_IBH\_DELAY** sets the delay between the compressor starting and the backup electric heater being turned on.

**T4\_IBH\_ON** sets the ambient temperature below which the backup electric heater is used. If the ambient temperature is above **T4\_IBH\_ON**, the backup electric heater is not used. The relationship between operation of the backup heater and the ambient is shown in Figure 3-8.27.

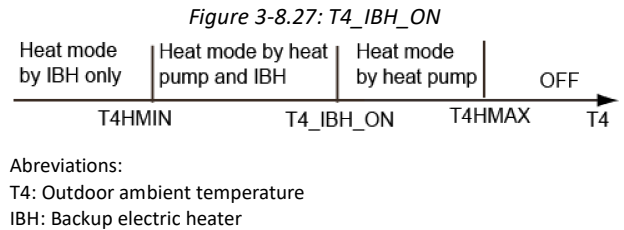

**dT1\_ASH\_ON** sets the temperature difference between the heat pump's leaving water set temperature (T1S) and the heat pump's leaving water temperature (T1) above which the additional heating source is on. When  $T1S - T1 \geq dT1\_AHS\_ON$  the additional heating source is on.

**t\_ASH\_DELAY** sets the delay between the compressor starting and the additional heating source being turned on.

**T4\_AHS\_ON** sets the ambient temperature below which the additional heating source is used. If the ambient temperature is above **T4\_AHS\_ON**, the additional heating source is not used. The relationship between operation of the additional heating source and the ambient is shown in the picture below.

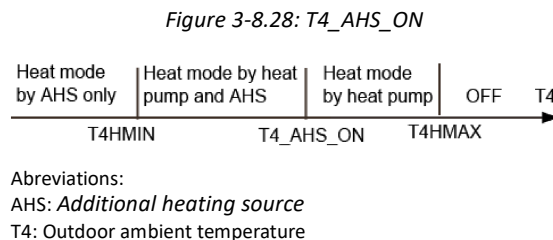

**IBH LOCATE** means IBH is installed for pipe heating.

**P\_IBH1, P\_IBH2** set heating capacity of IBH and **P\_TBH** sets heating capacity of TBH, which are used for energy consumption statistics.

## 8.11 HOLIDAY AWAY SETTING Menu

### MENU > FOR SERVICEMAN > HOLIDAY AWAY SETTING

The **HOLIDAY AWAY SETTING** menu settings are used to set the outlet water temperature to prevent water pipes freezing when away from home in cold weather seasons. In **HOLIDAY AWAY SETTING** the following parameters should be set.

**T1S\_H.A.\_H** sets the heat pump's leaving water set temperature for space heating mode when in holiday away mode.

*Figure 3-8.29: HOLIDAY AWAY SETTING menu*

8 HOLIDAY AWAY SETTING	
8.1 T1S_H.A._H	20°C
8.2 T5S_H.A._DHW	20°C
↕ ADJUST	⏪

T5S\_H.A.\_DHW sets the heat pump’s leaving water set temperature for DHW mode when in holiday away mode.

## 8.12 SERVICE CALL Menu

**MENU > FOR SERVICEMAN > SERVICE CALL**

In **SERVICE CALL** the following parameters can be set.

**PHONE NO.** and **MOBILE NO.** can be used to set after-sales service contact numbers. If set, these numbers are displayed to users in **MENU > FOR SERVICEMAN > SERVICE CALL**

Use ▼ ▲ to adjust the numerical values. The maximum length of the phone numbers is 14 digits.

Figure 3-8.30: SERVICE CALL menu

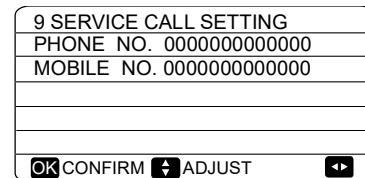

The black rectangle found between 0 and 9 when scrolling up and down using ▼ ▲ is converted to a blank space when the phone numbers are displayed to users in **MENU > FOR SERVICEMAN > SERVICE CALL** and can be used for phone numbers less than 14 digits in length.

## 8.13 RESTORE FACTORY SETTINGS

**MENU > FOR SERVICEMAN > RESTORE FACTORY SETTINGS**

**RESTORE FACTORY SETTINGS** is used to restore all the parameters set in the user interface to their factory defaults.

On selecting **YES**, the process of restoring all settings to their factory defaults begins and progress is displayed as a percentage.

Figure 3-8.31: RESTORE FACTORY SETTINGS screens

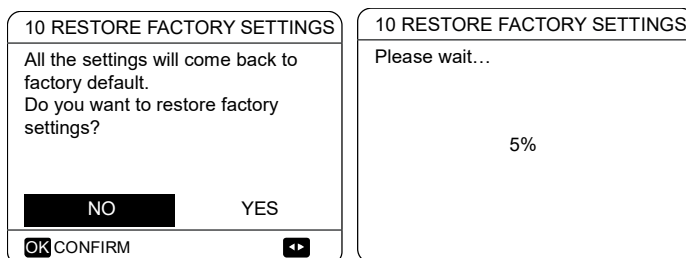

## 8.14 TEST RUN

### 8.14.1 TEST RUN Menu overview

**MENU > FOR SERVICEMAN > TEST RUN**

**TEST RUN** is used to check that the valves, air purge function, circulation pump, space cooling mode, space heating mode and DHW mode are all operating correctly.

Figure 3-8.32: TEST RUN start screen and TEST RUN menu

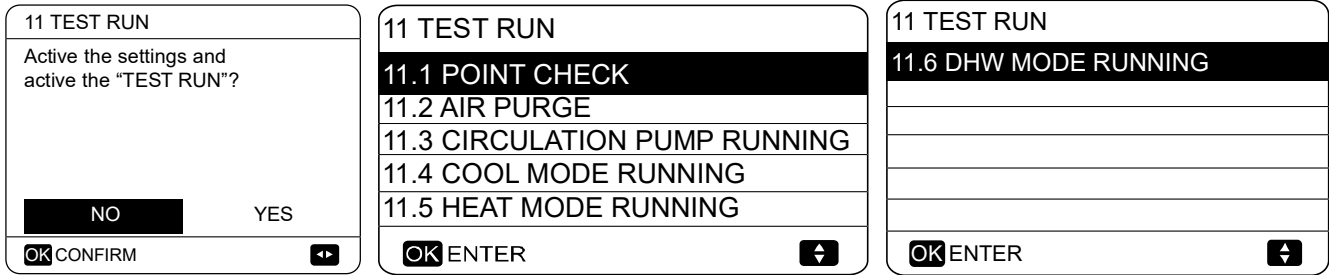

During test run, all buttons except OK are invalid. If you want to turn off the test run, please press OK. For example, when the unit is in air purge mode, after you press OK, the following page will be displayed:

Figure 3-8.33: Exit air purge screen

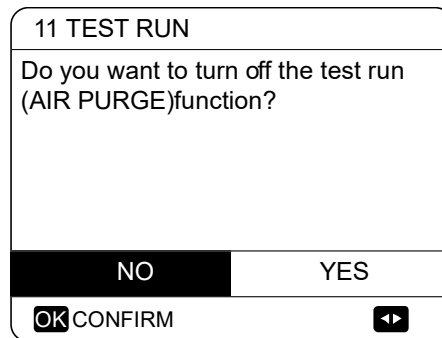

#### 8.14.2 POINT CHECK menu

**MENU > FOR SERVICEMAN > TEST RUN > POINT CHECK**

The **POINT CHECK** menu is used to check the operation of individual components. Use ▼ ▲ to scroll to the components you want to check and press ON/OFF to toggle the on/off state of the component. If a valve does not turn on/off when its on/off state is toggled or if a pump/heater does not operate when turned on, check the component's connection to the hydronic system main PCB.

Figure 3-8.34: POINT CHECK menu

11 TEST RUN	1/2
3-WAY VALVE 1	OFF
3-WAY VALVE 2	OFF
PUMP I	OFF
PUMP O	OFF
PUMP C	OFF
ON/OFF ON/OFF	↕

11 TEST RUN( POINT CHECK) 2/2	
PUMPSOLAR	OFF
PUMPDHW	OFF
INNER BACKUP HEATER	OFF
TANK HEATER	OFF
3-WAY VALVE 3	OFF
ON/OFF ON/OFF	↕

#### 8.14.3 AIR PURGE operation

**MENU > FOR SERVICEMAN > TEST RUN > AIR PURGE**

Once installation is complete it is important to run the air purge function to remove any air which may be present in the water piping and which could cause malfunctions during operation.

Figure 3-8.35: AIR PURGE operation

## S-Therm Yukon split series

The **AIR PURGE** operation is used to remove air from the water piping. Before running AIR PURGE mode, make sure that the air purge valve is open. When the air purge operation starts, the 3-way valve opens and the 2-way valve closes. 60 secs later the pump in the unit (PUMPI) operates for 10min during which the flow switch does not work. After the pump stops, the 3-way valve closes and the 2-way valve opens. 60 secs later both PUMPI and PUMPO operate until the next command is received. If any error code is displayed during the air purge operation, the cause should be investigated. Refer to Part 3, [9.2](#) "Error Code table".

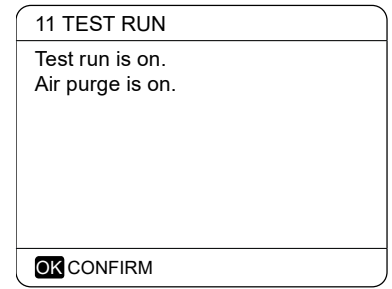

### 8.14.4 CIRCULATION PUMP RUNNING operation

**MENU > FOR SERVICEMAN > TEST RUN > CIRCULATION PUMP RUNNING**

The **CIRCULATION PUMP RUNNING** operation is used to check the operation of the circulation pump. When the circulation pump running operation starts, all running components stop. 60 secs later, the 3-way valve opens and the 2-way valve closes. After a further 60 secs PUMPI starts. 30 seconds later, if the flow switch detects that the water flow is normal, PUMPI operates for 3 min. After the pump stops 60s, the 3-way valve closes and the 2-way valve opens. 60s later both PUMI and PUMPO

Figure 3-8.36: CIRCULATION PUMP RUNNING display

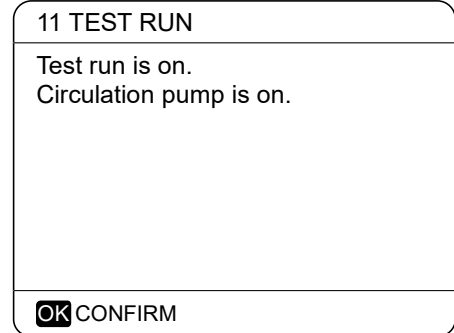

will operate. After a further 2 min the flow switch start to check the water flow. If the water flow rate is sufficient, both PUMPI and PUMPO operate until the next command is received. If the water flow rate is insufficient over any 15-second period, PUMPI and PUMPO stop and error code E8 is displayed. Refer to Part 3, [8.2](#) "Error Code table".

### 8.14.5 COOL MODE RUNNING operation

**MENU > FOR SERVICEMAN > TEST RUN > COOL MODE RUNNING**

The **COOL MODE RUNNING** operation is used to check the operation of the system in space cooling mode.

During the **COOL MODE RUNNING** operation, the S-Therm Yukon unit leaving water set temperature is 7°C. The current actual leaving water temperature is displayed on the user interface. The unit operates until the leaving water temperature drops to the set temperature or the next command is received.

Figure 3-8.37: COOL MODE RUNNING display

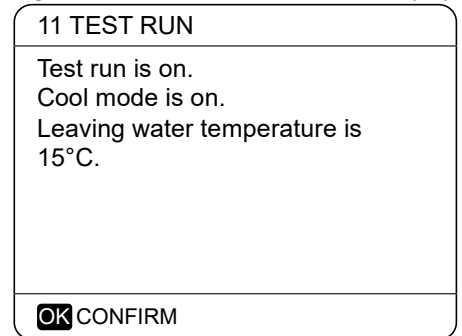

If any error code is displayed during the cool mode running operation, the cause should be investigated. Refer to Part 3, [8.2](#) "Error Code table".

### 8.14.6 HEAT MODE RUNNING operation

The **HEAT MODE RUNNING** operation is used to check the operation of the system in space heating mode.

During the **HEAT MODE RUNNING** operation the S-Therm Yukon unit leaving water set temperature is 35°C. The current actual leaving water temperature is displayed on the user interface. When the **HEAT MODE RUNNING** operation starts, the heat pump first runs for 10 mins.

After 10 mins:

- On systems where an auxiliary heat source (AHS) is installed, the AHS starts and runs for 10 mins (whilst the heat pump continues running), after which the AHS stops and the heat pump continues to operate until the water temperature rises to the set temperature or the heat mode running operation is exited by pressing **OK**.
- On systems where a backup electric heater is being used, the backup heater turn on (on models where the backup heater has a simple on/off control function). 3 mins later the backup electric heater will turn off. The heat pump will then operate until the water temperature rises to the set temperature or the **next command is received**.
- On systems with no auxiliary heat source (AHS), the heat pump will then operate until the water temperature rises to the set temperature or the **next command is received**.

If any error code is displayed during the cool mode running operation, the cause should be investigated. Refer to Part 3, [8.2](#) "Error Code table".

#### 8.14.7 DHW MODE RUNNING operation

The **DHW MODE RUNNING** operation is used to check the operation of the system in DHW mode.

During the **DHW MODE RUNNING** operation, the DHW set temperature is 55°C. On systems where a tank boost heater is installed, the tank boost heater will turn on once the heat pump has run for 10 mins. The tank boost heater will turn off 3 min later and the heat pump will operate until the water temperature rises to the set temperature or the **next command is received**.

### S-Therm Yukon split series

Figure 3-8.38: HEAT MODE RUNNING display

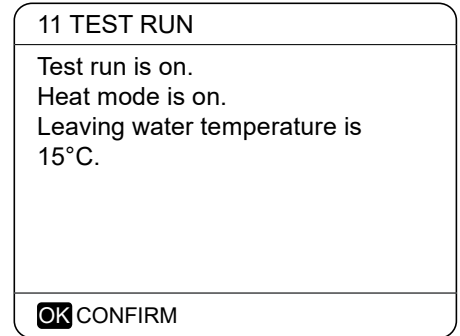
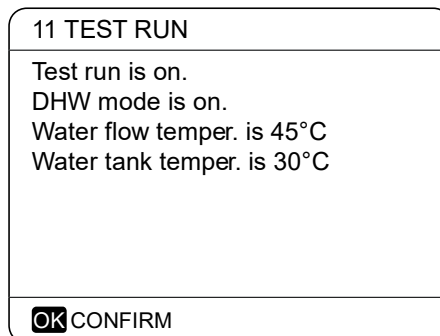

Figure 3-8.39: DHW MODE RUNNING display



## S-Therm Yukon split series

### 8.15 SPECIAL FUNCTION

#### 8.15.1 SPECIAL FUNCTION menu overview

**MENU > FOR SERVICEMAN > SPECIAL FUNCTION**

**SPECIAL FUNCTION** is used to pre-heating floor and drying up floor once installation is complete or the first time start up the unit or restart the unit after a long time stop.

Figure 3-8.40: Special functions menu

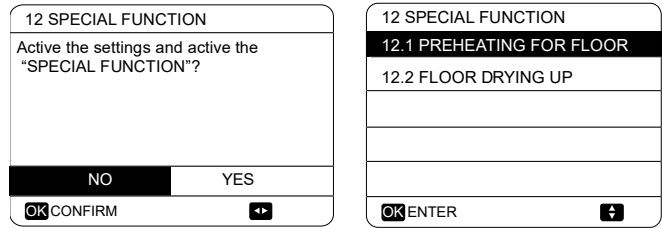

#### 8.15.2 PREHEATING FOR FLOOR

**MENU > FOR SERVICEMAN > SPECIAL FUNCTION > PREHEATING FOR FLOOR**

Before floor heating, if a large amount of water remains on the floor, the floor may be warped or even rupture during floor heating operation, in order to protect the floor, floor drying is necessary, during which the temperature of the floor should be increased gradually.

During first operation of the unit, air may remain in the water system which can cause malfunctions during operation. It is necessary to run the air purge function to release the air (make sure the air purge valve is open).

**T1S** sets the heat pump's leaving water set temperature in preheating for floor mode.

**t\_fristFH** sets the duration of preheating for floor mode.

The operation of the unit during preheating for floor mode is illustrated in Figure 3-8.42.

Figure 3-8.41: Preheating for floor menu

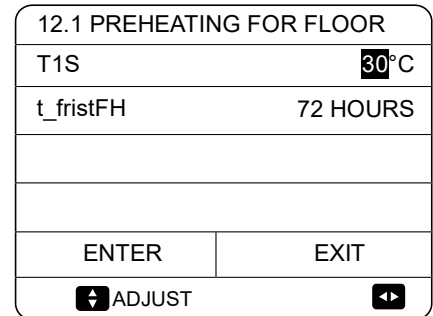
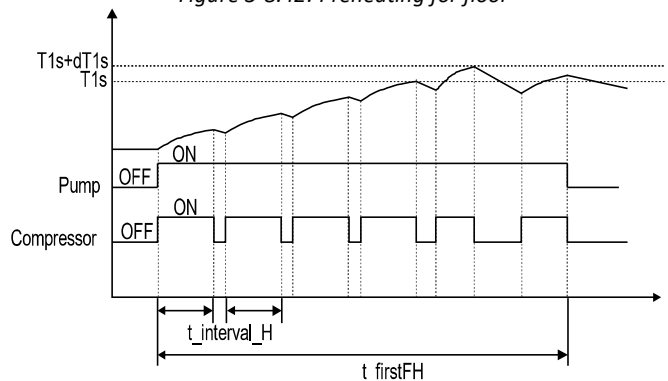

Figure 3-8.42: Preheating for floor



Abbreviations:

t\_interval\_H: Compressor re-start delay in space heating mode. (Refer to Part 3, [8.6](#) "HEAT MODE SETTING Menu").

Whilst the preheating for floor operation is running, the number of minutes that it has been running for and the heat pump's leaving water temperature are displayed on the user interface. During the preheating for floor operation all buttons except **OK** are inactivated. To exit the preheating for floor operation, press **OK** and then select **YES** when prompted. Refer to Figure 3-8.43.

Figure 3-8.43: Preheating for floor screens

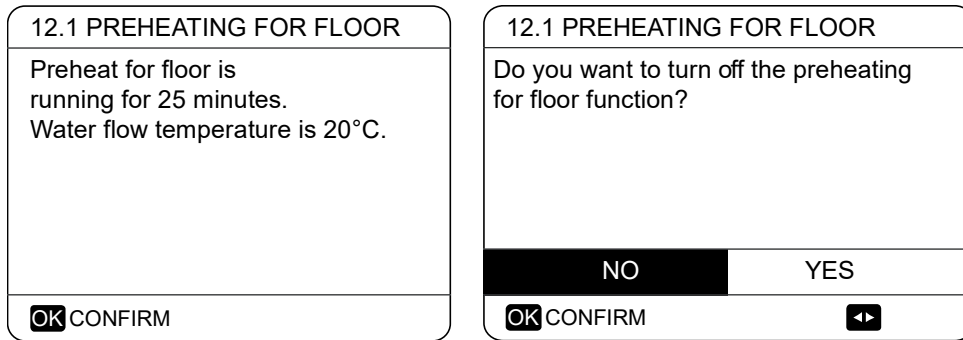

8.15.3 FLOOR DRYING UP

MENU > FOR SERVICEMAN > SPECIAL FUNCTION > FLOOR DRYING UP

For newly-installed under-floor heating systems, floor drying up mode can be used to remove moisture from the floor slab and subfloor to prevent warping or rupture of the floor during floor heating operation. There are three phases to the floor drying up operation:

- Phase 1: gradual temperature increase from a starting point of 25°C to the peak temperature
- Phase 2: maintain peak temperature
- Phase 3: gradual temperature decrease from the peak temperature to 45°C

Figure 3-8.44: FLOOR DRYING UP menu

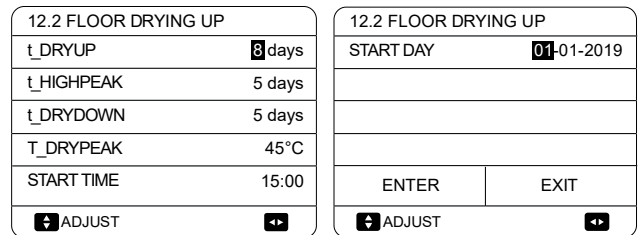

t\_DRYUP sets the duration of Phase 1.

t\_HIGHPEAK sets the duration of Phase 2.

t\_DRYDOWN is the duration of Phase 3.

T\_DRYPEAK sets the heat pump’s leaving water set temperature for Phase 2.

START TIME sets the floor drying up operation start time.

START DATE sets the floor drying up operation start date.

Figure 3-8.45: FLOOR DRYING UP settings

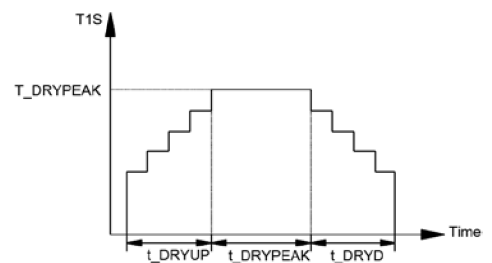

The heat pump’s leaving water set temperature during the floor drying up operation is illustrated in Figure 3-8.45.

During the floor drying up operation all buttons except OK are inactivated. To exit the floor drying up operation, press OK and then select YES when prompted.

Figure 3-8.46: FLOOR DRYING UP screen

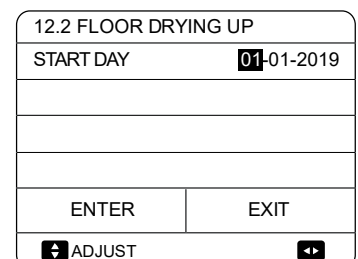

Note: In the event of a heat pump malfunction, floor drying up mode will continue if a backup electric heater and/or additional heating source is available and configured to support space heating mode.

## S-Therm Yukon split series

### 8.16 AUTO RESTART

**MENU > FOR SERVICEMAN > AUTO RESTART**

**AUTO RESTART** sets whether or not the unit re-applies the user interface settings when the power returns following a power failure. Select **YES** to enable auto restart or **NON** to disable auto restart.

If the auto restart function is enabled, when the power returns following a power failure, the unit re-applies the user interface settings from before the power failure. If the auto restart function is disabled, when the power returns after a power failure, the unit won't auto restart.

Figure 3-8.47: AUTO RESTART menu

13 AUTO RESTART	
13.1 COOL/HEAT MODE	<b>YES</b>
13.2 DHW MODE	NON
ADJUST	

### 8.17 POWER INPUT LIMITATION

**MENU > FOR SERVICEMAN > POWER INPUT LIMITATION**

**POWER INPUT LIMITATION** sets the type of power input limitation and the setting range is 0-8. If the unit will operate at larger power input, 0 should be selected. If the unit will operate at a lower power input, 1-8 should be selected and the power input and capacity will decrease.

Figure 3-8.48: POWER INPUT LIMITATION menu

14 POWER INPUT LIMITATION	
14.1 POWER INPUT LIMITATION	<b>0</b>
ADJUST	

Figure 3-8.49: Limitation value (unit:A)

Model \ No.	0	1	2	3	4	5	6	7	8
4/6kW	18	18	16	15	14	13	12	12	12
8/10kW	19	19	18	16	14	12	12	12	12
12/14kW(1N)	30	30	28	26	24	22	20	18	16
16kW(1N)	30	30	29	27	25	23	21	19	17
12/14kW(3N)	14	14	13	12	11	10	9	9	9
16kW(3N)	14	14	13	12	11	10	9	9	9

### 8.18 INPUT DEFINE

**MENU > FOR SERVICEMAN > INPUT DEFINE**

Figure 3-8.50: INPUT DEFINE

15 INPUT DEFINE	
15.1 ON/OFF(M1M2)	<b>REMOTE</b>
15.2 SMART GRID	NON
15.3 T1b(Tw2)	NON
15.4 Tbt1	NON
15.5 Tbt2	NON
ADJUST	

15 INPUT DEFINE	
15.6 Ta	HMI
15.7 Ta-adj	-2°C
15.8 SOLAR INPUT	NON
15.9 F-PIPE LENGTH	<10m
15.10 RT/Ta_PCB	NON
ADJUST	

15 INPUT DEFINE	
15.11 PUMPI SILENT MODE	NON
ADJUST	

**INPUT DEFINE** sets sensors and functions to fulfill with installation.

**ON/OFF(M1M2)** sets the control function of M1M2 for remote ON/OFF of unit or AHS or TBH

**SMART GRID** sets whether SMART GRID control signal is connected to hydronic PCB.

**T1b(Tw2)** sets whether T1b sensor exist in the installation.

**Tbt1** set whether balance tank temperature sensors are installed in the balance tank. (Tbt1 sensor, individually purchase;Tbt2,

reserved)

**Ta** sets the Ta sensor connection type (HMI: Ta on wired controller; IDU: Ta connected on hydronic PCB)

**Ta-adj** is an correction value for Ta.

**SOLAR INPUT** sets whether solar control signal is connected to hydronic PCB. (0=NON; 1=CN18; Tsolar 2=CN11SL1SL2)

**F-PIPE LENGTH** sets the length of refrigerant pipes between outdoor unit and indoor unit.

**RT/Ta\_PCB** sets whether M-kit is valid.

**Pump silent mode** can decrease water pump maximum output by 5% in order to decrease the noise of heat pump.

## 8.19 HMI ADDRESS SET

**MENU > FOR SERVICEMAN > HMI ADDRESS SET**

Figure 3-8.52: HMI ADDRESS SET

17 HMI ADDRESS SET	
17.1 HMI SET	MASTER
17.2 HMI ADDRESS FOR BMS	1
<input type="button" value="ADJUST"/> <input type="button" value="↕"/>	

**HMI SET** sets the wired controller is master or slave. (0=MASTER, 1=SLAVE)

When HMI SET is set to SLAVE, the controller can only switch the operation mode, turn on or off, set the temperature, and cannot set other parameters and functions.

**HMI ADDRESS FOR BMS** sets the HMI address code for BMS.(only valid for master controller)

# S-Therm Yukon split series

## 9 Operation parameter

### MENU > OPERATION PARAMETER

This menu is for installer or service engineer reviewing the operation parameters. There are nine pages for the operating parameter as following

Figure 3-9.1: Operation parameter

OPERATION PARAMETER	#01
ONLINE UNITS NUMBER	1
OPERATE MODE	COOL
SV1 STATE	ON
SV2 STATE	OFF
SV3 STATE	OFF
PUMP_I	ON
ADDRESS	1/9

OPERATION PARAMETER	#01
PUMP-O	OFF
PUMP-C	OFF
PUMP-S	OFF
PUMP-D	OFF
PIPE BACKUP HEATER	OFF
TANK BACKUP HEATER	ON
ADDRESS	2/9

OPERATION PARAMETER	#01
GAS BOILER	OFF
T1 LEAVING WATER TEMP.	35°C
WATER FLOW	1.72m <sup>3</sup> /h
HEAT PUMP CAPACTIY	11.52kW
POWER CONSUM.	1000kWh
Ta ROOM TEMP	25°C
ADDRESS	3/9

OPERATION PARAMETER	#01
T5 WATER TANK TEMP.	53°C
Tw2 CIRCUIT2 WATER TEMP.	35°C
TIS' C1 CLIMATE CURVE TEMP.	35°C
TIS2' C2 CLIMATE CURVE TEMP.	35°C
TW_O PLATE W-OUTLET TEMP.	35°C
TW_I PLATE W-OUTLET TEMP.	30°C
ADDRESS	4/9

OPERATION PARAMETER	#01
Tbt1 BUFFERTANK_UP TEMP.	35°C
Tbt2 BUFFERTANK_LOW TEMP.	35°C
Tsolar	25°C
IDU SOFTWARE	01-09-2019V01
ADDRESS	5/9

OPERATION PARAMETER	#01
ODU MODEL	6kW
COMP.CURRENT	12A
COMP.FREQUENCY	24Hz
COMP.RUN TIME	54 MIN
COMP.TOTAL RUN TIME	1000Hrs
EXPANSION VALVE	200P
ADDRESS	6/9

OPERATION PARAMETER	#01
FAN SPEED	600R/MIN
IDU TARGET FREQUENCY	46Hz
FREQUENCY LIMITED TYPE	5
SUPPLY VOLTAGE	230V
DC GENERATRIX VOLTAGE	420V
DC GENERATRIX CURRENT	18A
ADDRESS	7/9

OPERATION PARAMETER	#01
TW_O PLATE W-OUTLET TEMP.	35°C
TW_I PLATE W-INLET TEMP.	30°C
T2 PLATE F-OUT TEMP.	35°C
T2B PLATE F-IN TEMP.	35°C
Th COMP. SUCTION TEMP.	5°C
Tp COMP. DISCHARGE TEMP.	75°C
ADDRESS	8/9

OPERATION PARAMETER	#01
T3 OUTDOOR EXCHANGE TEMP.	5°C
T4 OUTDOOR AIR TEMP.	5°C
TF MODULE TEMP.	55°C
P1 COMP. PRESSURE	2300kPa
ODU SOFTWARE	01-09-2018V01
HMI SOFTWARE	01-09-2018V01
ADDRESS	9/9

## 10 Network Configuration Guidelines

The wired controller realizes intelligent control with a built-in WIFI module, which receives control signal from the APP. Before connecting the WLAN, please check for it if the router in your environment is active and make sure that the wired controller is well-connected to the wireless signal. When the product is connected to the network, please make sure that the phone is as close as possible to the product. S-Therm Yukon only supports 2.4GHz band routers at present. Special characters (punctuation, spaces, etc.) are not recommended as part of the WLAN name. It is recommended that you connect no more than 10 devices to a single router lest home appliances are affected by weak or unstable network signal. If the password of the router or WLAN is changed, clear all settings and reset the appliance. APP interface changes from time to time as APP is updated and may change slightly vary from those in this document.

### 10.1 Install APP

Scan the following QR code to install Comfort Home App



Please research "Comfort Home" in APP STORE or GOOGLE PLAY to install the APP. This APP is only applicable to Android 7.0 and IOS7, or newer operation systems.

Please input your registration code. Or scan the QR code on the controller packaging box if existed. And register your account according to the guidance.

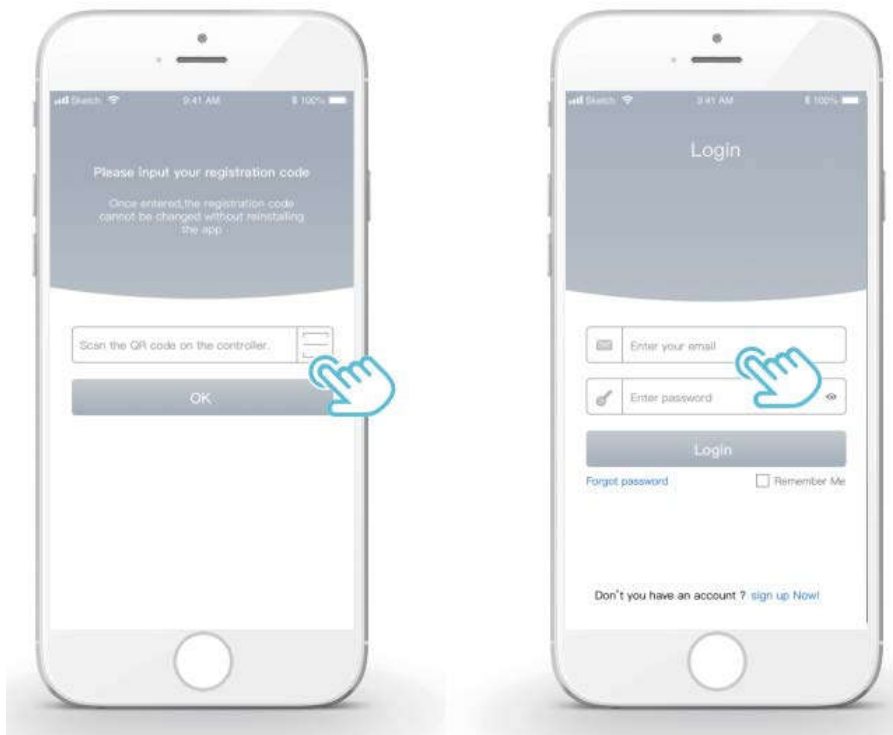

## S-Therm Yukon split series

- 1) Add your device following the guidance

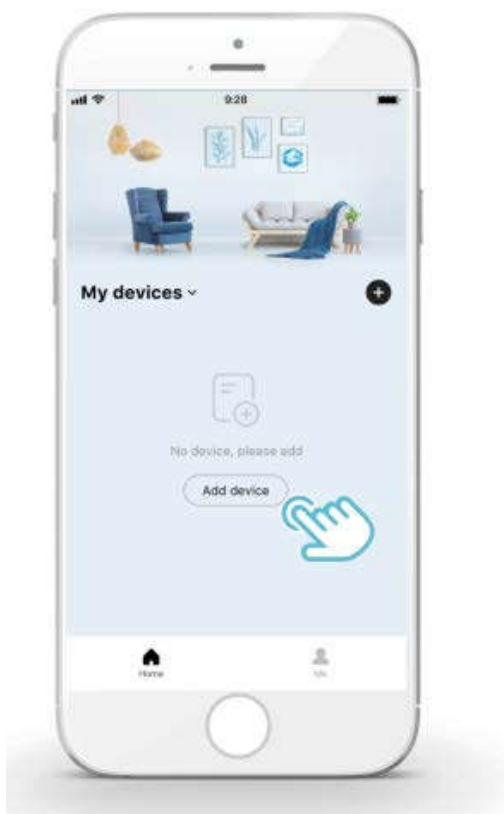

- 2) Operate the wired controller according to APP prompts

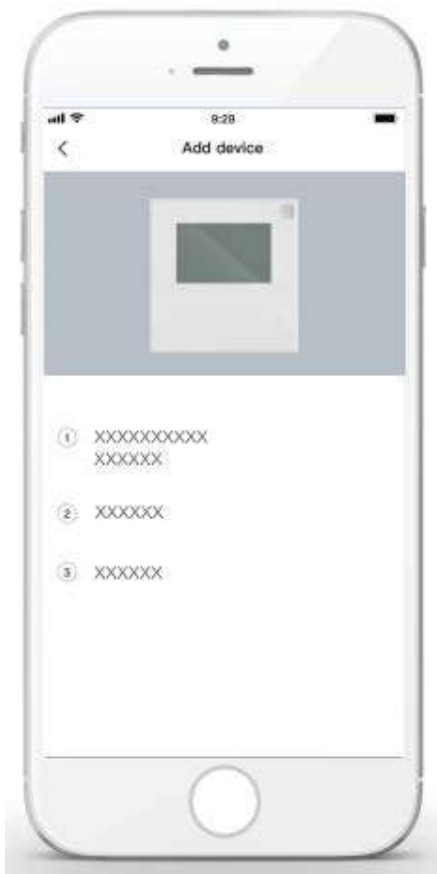

- 3) Wait for the home appliance to connect, and click “Sure”.

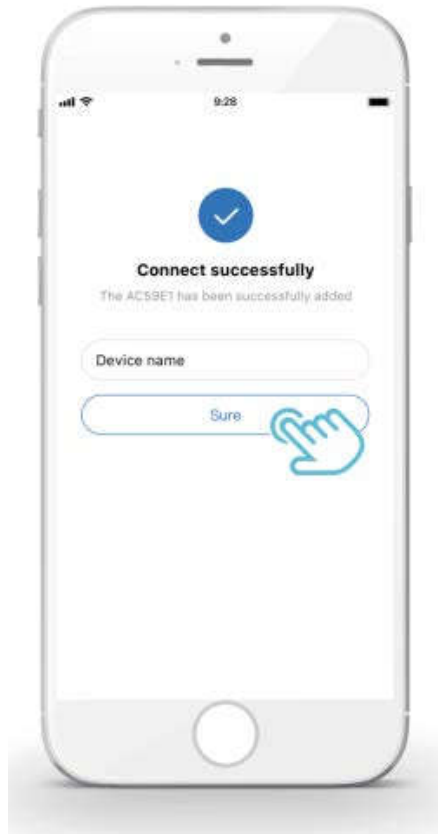

- 4) After the appliance is successfully connected, the LCD icon“” of the wired controller is constantly on, and the heat pump can be controlled through the APP.
- 5) If the network distribution process fails, or the mobile connection demands reconnection and replacement, operate “RESTORE WLAN SETTING” on the wired controller, and then repeat the above process.



### **Warning and troubleshooting for networking failures**

When the product is connected to the network, please make sure that the phone is as close as possible to the product.

---

We only support 2.4GHz band routers at present.

---

Special characters (punctuation, spaces, etc.) are not recommended as part of the WLAN name.

---

It is recommended that you connect no more than 10 devices to a single router lest home appliances are affected by weak or unstable network signal.

---

If the password of the router or WLAN is changed, clear all settings and reset the appliance.

---

The contents of APP might change in version updates and actual operation shall prevail.

### WIFI information

WIFI transmit frequency range:2.400 ~ 2.4835 GHz  
EIRP not more than 20dbm

## 11 USB Function Guidelines

### 11.1 Parameters setting transfer between wired controllers

Installer can quickly copy the wired controller parameter settings from unit A to unit B via USB disk, which save the time of on-site installation. Steps are as follows:

Step 1:

Plug U disk into the port of hydronic PCB of A unit.

“USB” appears on digital display

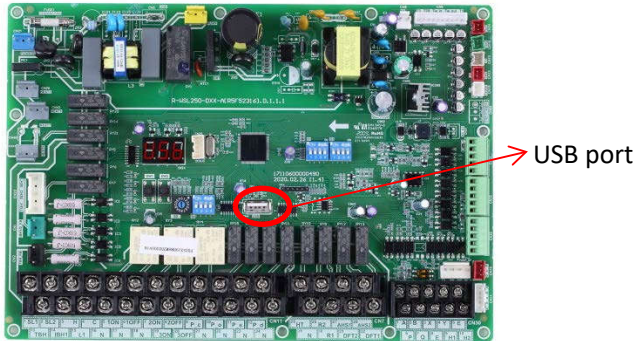

Wired controller interface automatically changes

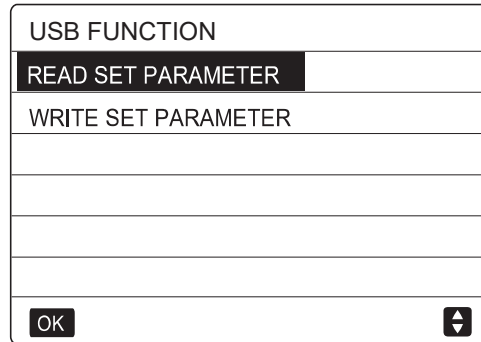

Step 2:

Select “READ SET PARAMETER” and press “OK” button then rate of progress will appear. When the process is finished, “SUCCESS” appears below and an EXCEL file which can not be seen in the wired controller interface but users can find it on computer will be generated inside the USB disk.

Select “READ SET PARAMETER”

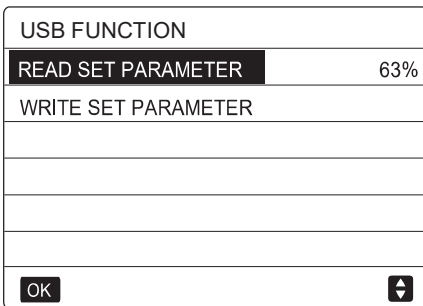

Finished

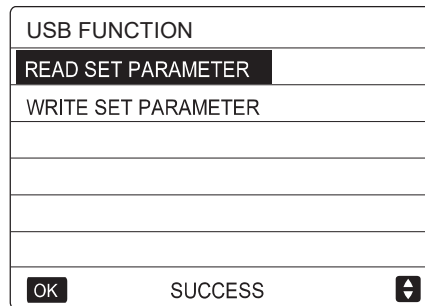

EXCEL generated

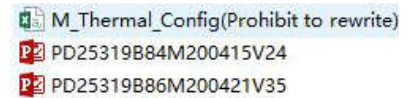

After that, if parameter correction is needed, please connect the USB with computer and open the EXCEL file to change parameters and then save it. Please do not change the file name or format. Parameters are not allowed for non-professionals to change and Sinclair recommends to use the wired controller to change the parameters.

Step 3:

Plug USB disk into the port of hydronic PCB of B unit and select “WRITE SET PARAMETER” then rate of progress will appear. When the process is finished, “SUCCESS” appears below.

Select “WRITE SET PARAMETER”

Finished

## S-Therm Yukon split series

USB FUNCTION
READ SET PARAMETER
<b>WRITE SET PARAMETER</b> 25%
OK <span style="float: right;">↕</span>

USB FUNCTION
READ SET PARAMETER
<b>WRITE SET PARAMETER</b>
OK SUCCESS <span style="float: right;">↕</span>

### 11.2 Convenient program upgrade for unit

There is no need to carry any heavy equipment but only USB disk can realize program upgrade. Steps are as follows:

Step 1:

Copy new program in U disk root directory where other files in bin format are not allowed in

Step 2:

Power on and make sure communication is normal.

Step 3:

Plug U disk into the port of hydronic PCB.

“USB” appears on digital display

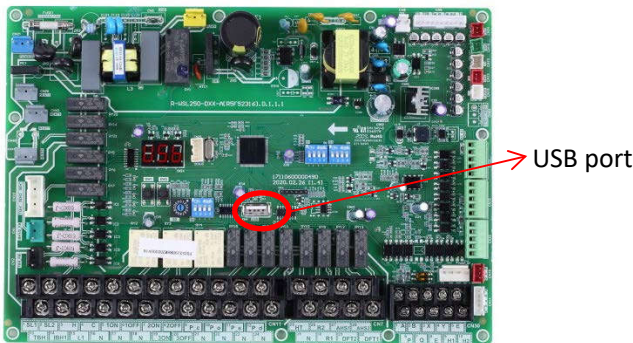

Wired controller interface automatically changes

USB FUNCTION
<b>READ SET PARAMETER</b>
WRITE SET PARAMETER
PD25319B84M200415V24.bin
PD25319B86M200421V35.bin
OK <span style="float: right;">↕</span>

Step 4:

Please distinguish between programs for main control PCB and hydronic PCB. Select one of them and press “OK” button then rate of progress appears. When the process is finished, “SUCCESS” appears below. For upgrading outdoor unit, the process normally lasts for several minutes while only few seconds is needed for indoor unit.

Select program

USB FUNCTION
READ SET PARAMETER
WRITE SET PARAMETER
<b>PD25319B84M200415V24.bin</b> 51%
PD25319B86M200421V35.bin
OK <span style="float: right;">↕</span>

Finished

USB FUNCTION
READ SET PARAMETER
WRITE SET PARAMETER
<b>PD25319B84M200415V24.bin</b>
PD25319B86M200421V35.bin
OK SUCCESS <span style="float: right;">↕</span>

Step 5:

Pull out U disk and power on again to finish upgrading program. Check the program version to make sure upgrade is successful.

## Check IDU software version

OPERATION PARAMETER	#00
Tbt1 BUFFERTANK_UP TEMP.	XX °C
Tbt2 BUFFERTANK_LOW TEMP.	XX °C
Tsolar	XX °C
IDU SOFTWARE	XX-XX-XXXXXXX
ADDRESS	5/9

## Check ODU software version

OPERATION PARAMETER	#00
T3 OUTDOOR EXCHANGE TEMP.	XX °C
T4 OUTDOOR AIR TEMP	XX °C
TF MODULE TEMP.	XX °C
P1 COMP PRESSURE	XX Kpa
ODU SOFTWARE	XX-XX-XXXXXXX
HMI SOFTWARE	XX-XX-XXXXXXX
ADDRESS	9/9

## 12 Climate Related Curves

The climate related curves can be selected in the user interface, **MENU > PRESET TEMPERATURE > WEATHER TEMP. SET.**

The curves for heating mode and ECO heating mode are the same but the default curve is curve 4 in heating mode, while in ECO mode, the default curve is curve 6. The default curves for cooling mode is curve 4. Once the curve is selected, the leaving water set temperature (T1s) is determined by the outdoor temperature. In each mode, each curve from the eight curves in the user interface can be selected. The relationship between outdoor ambient temperature (T4) and leaving water set temperature (T1s) is described as in Figure 3-12.2, Figure 3-12.3, Figure 3-12.4 and Figure 3-12.5.

Figure 3-12.1: WEATHER TEMP.SET menu

PRESET TEMPERATURE		
PRESET TEMP.	WEATHER TEMP.SET	ECO MODE
ZONE1 C-MODE LOW TEMP.		OFF
ZONE1 H-MODE LOW TEMP.		OFF
ZONE2 C-MODE LOW TEMP.		OFF
ZONE2 H-MODE LOW TEMP.		OFF
ON/OFF	ON/OFF	

The automatic setting curves are the ninth curve for cooling and heating mode, the ninth curve can be set as in Figure 3-12.6 and Figure 3-12.7.

Figure 3-12.2: Low temperature curves for heating mode<sup>1</sup>

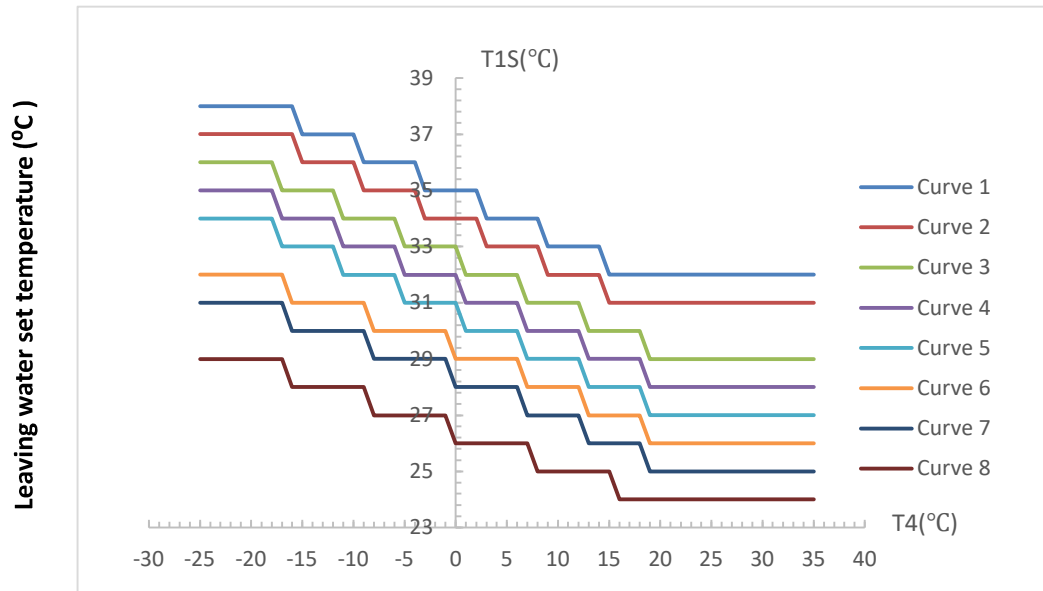

Notes:

1. It only has the curves of the low temperature setting for heating, if the low temperature is set for heating.
2. Curve 4 is default in low temperature heating mode and curve 6 is default in ECO mode.

Figure 3-12.3: High temperature curves for heating mode<sup>1</sup>

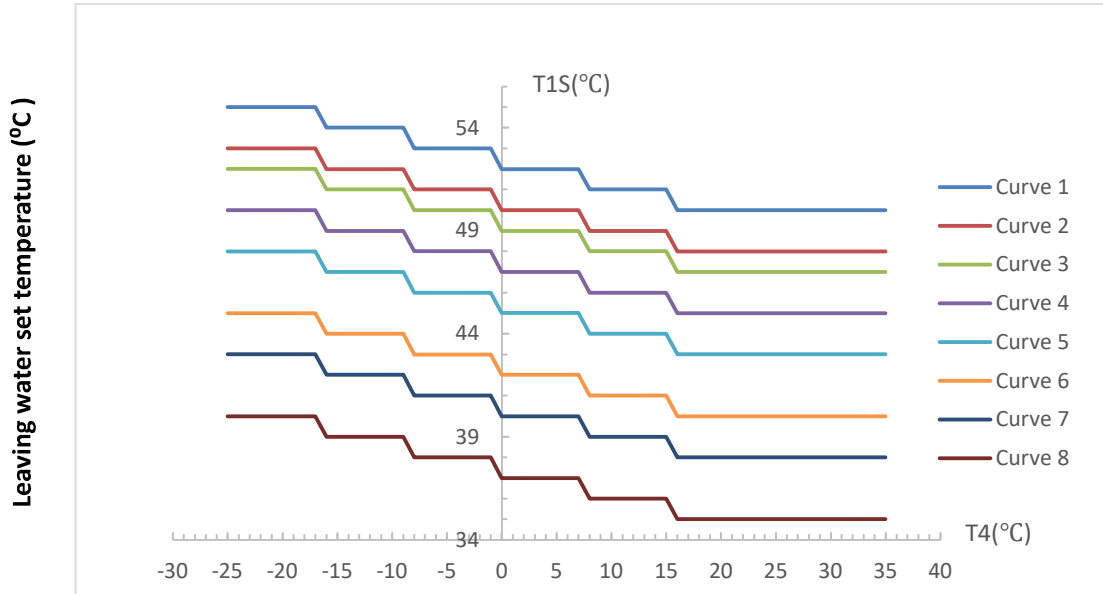

Notes:

1. It only has the curves of the high temperature setting for heating, if the high temperature is set for heating.
2. Curve 4 is default in high temperature heating mode and curve 6 is default in ECO mode.

Figure 3-12.4: Low temperature curves for cooling mode<sup>1</sup>

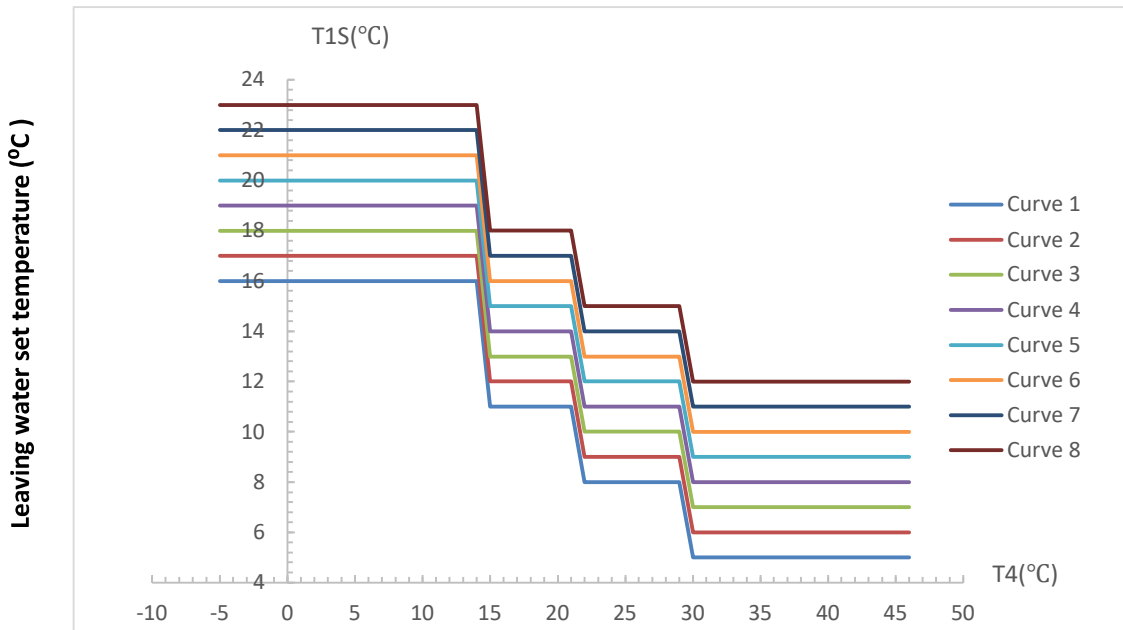

Notes:

1. It only has the curves of the low temperature setting for cooling, if the low temperature is set for cooling.
2. Curve 4 is default in low temperature cooling mode.

Figure 3-12.5: High temperature curves for cooling mode<sup>1</sup>

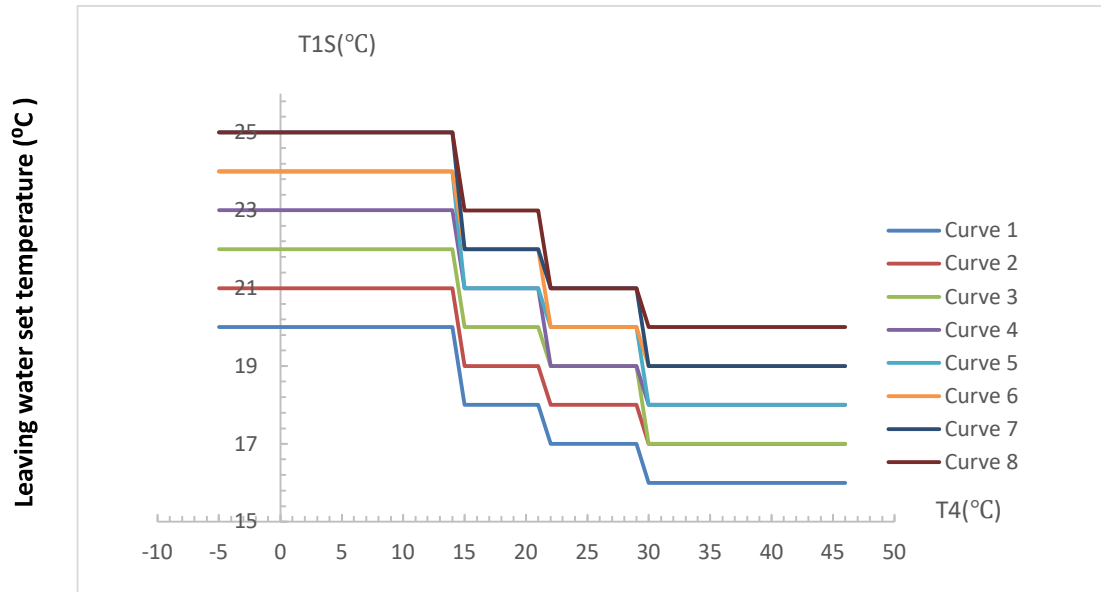

Notes:

1. It only has the curves of the high temperature setting for cooling, if the high temperature is set for cooling.
2. Curve 4 is default in high temperature cooling mode.

Figure 3-12.6: Automatic setting curve for heating mode

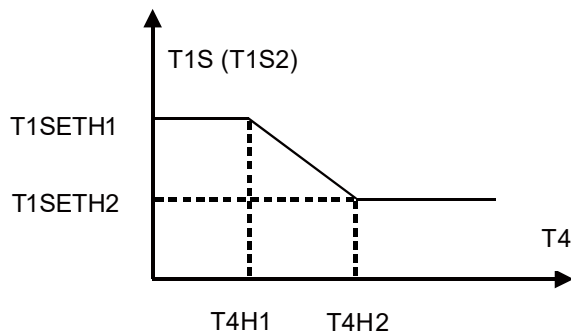
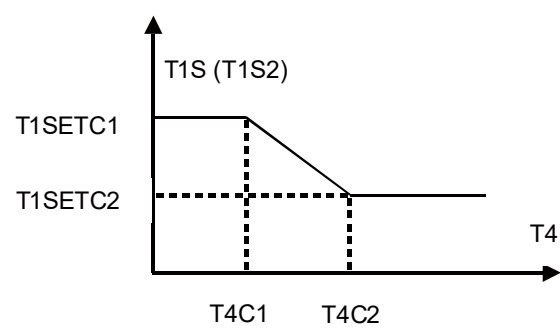

Figure 3-12.7: Automatic setting curve for cooling mode



The setting of T1SETH1, T1SETH2, T4H1, T4H2 refer to Part 3, 8.6" HEATING MODE SETTING Menu" and T1SETC1, T1SETC2, T4C1, T4C2 refer to Part 3, 8.5" COOLING MODE SETTING Menu".

13 Error Code Table

Table 3-13.1: Error code table

Error code	Content
C7	Transducer module temperature too high protection
E0	Water flow failure (E8 appears 3 times)
E1	Phase sequence error (for 3 phase models)
E2	Communication error between the main control board of hydraulic module and user interface
E3	Backup electric heater exchanger water outlet temperature sensor T1 error
E4	Domestic hot water tank temperature sensor T5 error
E5	Air side heat exchanger refrigerant outlet temperature sensor T3 error
E6	Outdoor ambient temperature sensor T4 error
E7	Balance tank sensor Tbt1 error
E8	Water flow failure within 3 times
E9	Suction pipe temperature sensor Th error
EA	Discharge pipe temperature sensor Tp error
Eb	Solar board sensor Tsolar error
Ec	Balance tank sensor Tbt2 error
Ed	Water side heat exchanger water inlet temperature sensor Twin error
EE.	Hydronic box EEPROM error
F1	DC generatrix voltage is too low
H0	Communication error between outdoor unit main control chip and hydronic box main control chip
H1	Communication error between outdoor unit main control chip and inverter driver chip
H2	Water side heat exchanger refrigerant outlet (liquid pipe) temperature sensor T2 error
H3	Water side heat exchanger refrigerant inlet (gas pipe) temperature sensor T2B error
H4	Inverter module protection (L0/L1 appear 3 times in one hour)
H5	Room temperature sensor Ta error
H6	DC fan error
H7	Abnormal main circuit voltage
H8	Pressure sensor error
H9	Zone 2 water outlet temperature sensor Tw2 error
HA	Water side heat exchanger water outlet temperature sensor error
Hb	PP protection appears three times in a row and Twout<7°C
H.F.	Invert module EEPROM error
HH	H6 appears 10 times in 120min
HP	Low pressure protection (pressure < 0.6MPa for 3 times in one hour)
P0	Low pressure protection
P1	High pressure protection
P3	Compressor current protection
P4	Discharge temperature sensor Tp protection
P5	High temperature difference between water side heat exchanger water inlet and water outlet temperatures protection
P6	Inverter module protection
L0	Inverter module protection
L1	DC bus low voltage protection
L2	DC bus high voltage protection

*Table 3-13.1: Error code table(continued)*

L4	MCE error
L5	Zero speed protection
L7	Phase sequence error
L8	Compressor frequency variation greater than 15Hz within one second protection
L9	Actual compressor frequency differs from target frequency by more than 15Hz protection
Pb	Water side heat exchanger anti-freeze protection
Pd	Air side heat exchanger refrigerant outlet temperature sensor T3 error
PP	Water side heat exchanger inlet temperature is higher than outlet temperature in heating/DHW mode
bH	PED board error

# Exploded spare parts view

MSH-60EB

MSH-80EB

MSH-100EB

MSH-120EB

MSH-140EB

MSH-160EB

MSH-60IB/3

MSH-100IB-3/9

MSH-160IB-3/9

# MSH-60EB

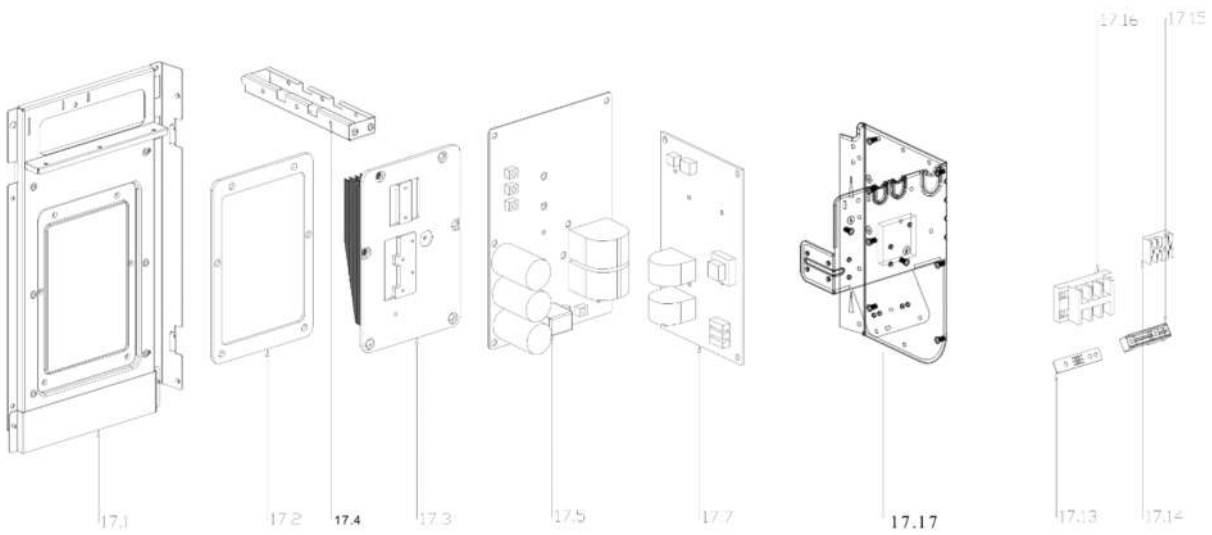
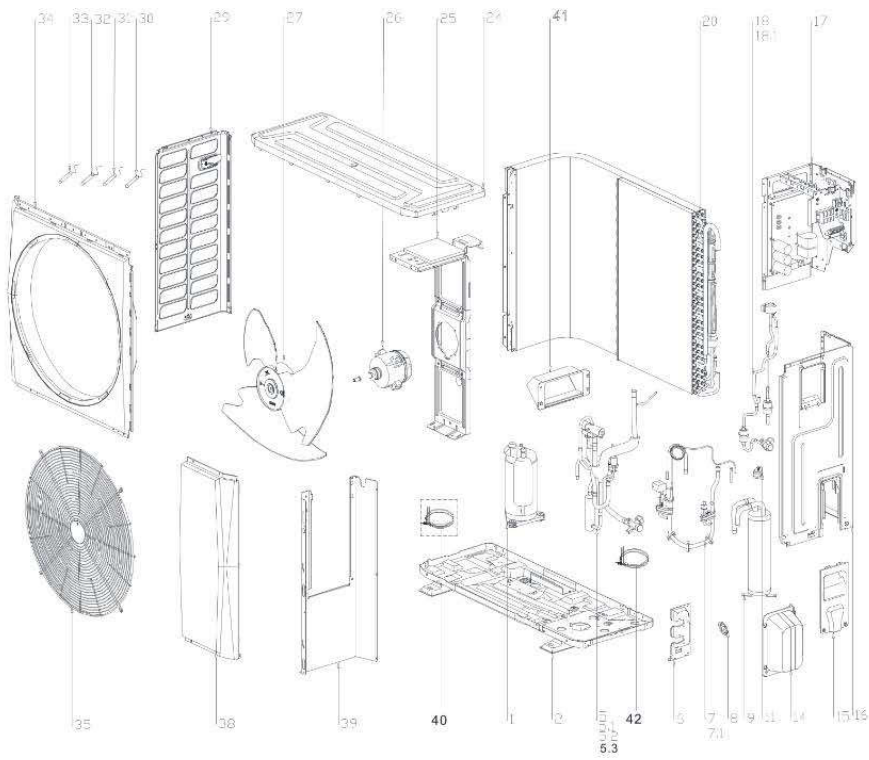

# S-Therm Yukon split series



EX_ID	Spare Parts Code	Part Name(EN)	QTY.	Remark
1	11103020005759	DC Inverter Rotary Compressor	1	
2	12227000016165	Chassis part	1	
5	15427000004445	Four-way valve assembly	1	
5.1	15500216000103	4-way valve suite	1	
5.2	11201008000033	Pressure sensor	1	
5.3	17400516000808	Pressure switch	1	
6	12223000012694	Valve plate	1	
7	15427000004447	Suction pipe assembly	1	
7.1	17400516000008	Pressure switch	1	
8	12600401003653	Rubber washer	1	
9	15425300003060	Liquid storage tank assembly	1	
11	12600401000158	rubber base	1	
14	12122000029462	Water collector	1	
15	12227000011039	Large handle	1	
16	12223000012692	Right Rear Side Panel Assembly	1	
17	17223000A07099	E-box assembly	1	
17.1	12227000015799	Radiator support plate	1	
17.2	12627000000646	Seal gasket	1	
17.3	12927000001412	Optional heat exchanger	1	
17.4	12227100007240	Connecting plate assembly	1	
17.5	17125300003909	Module board assembly	1	
17.7	17125300004203	Outdoor main control board assembly	1	
17.13	12122000006931	Insulation plate	1	
17.14	17400401000183	Wire joint	1	
17.15	12100303001082	Wire clip	1	
17.16	17400401000026	Terminal	1	
17.16	17400401000073	Wire joint	1	
17.17	12223000015288	Electrical appliance mounting plate assembly	1	
18	15427000004444	Expansion valve assembly	1	
18.1	15500213001526	Electronic expansion valve suite	1	
20	15827000001668	Condenser part	1	
24	12227000012331	Top cover assembly	1	
25	12223000012695	Motor holder assembly	1	
26	11002015010746	Brushless DC Motor	1	
27	12100105000022	Axial flow fan	1	
29	12223000012696	Column	1	
30	11201007000039	Room Temperature Sensor	1	T4 : OUTDOOR AMBIENT TEMPERATURE SENSOR
31	11201007002463	Discharge Temperature Sensor	1	Tp : COMP DISCHARGE TEMPERATURE
32	11201007000382	Pipe Temperature Sensor	1	Th : EVAPORATOR INPUT TEMPERATURE
33	11201007000164	Pipe Temperature Sensor	1	T3:CONDENSOR TEMPERATURE SENSOR
34	12223000012698	Front panel	1	
35	12927000001413	Wind nets	1	

38	12223000012691	Right Front Side Panel Assembly	1	
39	12222500002372	Partition board assembly	1	
40	17402001000259	Chassis electric heating	1	Optional function parts
41	12127000001300	Rainproof cover	1	
42	17402001000339	Compressor electric heater	2	

# MSH-60IB/3

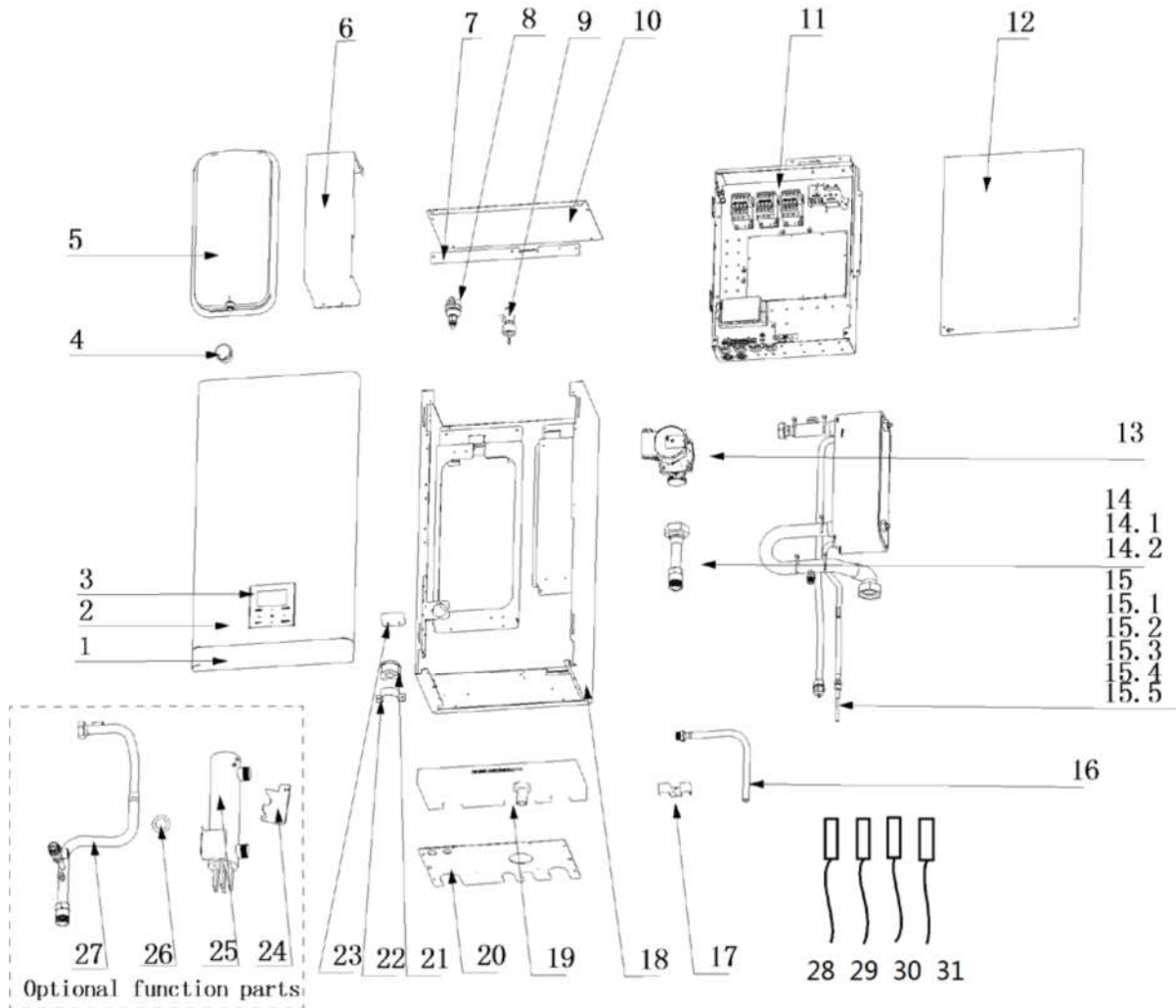

EX_ID	Spare Parts Code	Part Name(EN)	QTY.	Remark
1	12110600000129	Decorative plate	1	
2	12210600001518	Panel	1	
2	17317100A35072	Wired controller	1	
4	17500501000121	Pressure gauge	1	
5	15500509000107	closed expansion vessels with built in diaphragm	1	
6	12210600001491	Plate heat exchanger fixed plate	1	
7	12210600001515	E-Part box bracket	1	
8	15500211000047	Exhaust valve	1	
9	17400510000474	Water flow switch	1	
10	12210600001506	Top cover	1	
11	17210600A00190	E-part box assembly	1	
11.1	17110600000570	Hydraulic module, Main control board assembly	1	
12	12210600001629	Electric control box cover	1	
13	17400802001733	Shielded pump	1	
14	15410600000433	Water Inlet pipe assembly	1	
14.1	15500303002324	Pipe joint	1	
14.2	15500406000033	Hex nut	1	
15	15710600000263	Plate heat exchanger assembly	1	
15.1	15710600000264	Plate heat exchanger assembly	1	
15.1.1	15700101000977	Plate heat exchanger	1	
15.1.2	15410600000491	Water outlet pipe assembly	1	
15.1.3	15410600000431	Water Inlet pipe assembly	1	
15.1.4	15110600000659	Liquid pipe assembly	1	
15.1.5	15110600000652	Gas pipe assembly	1	
16	12100509000532	Connecting hose	1	
17	12210600001513	Refrigerant pipe fixed plate	1	
18	12210600001493	Base assembly	1	
19	12210600001517	Drainage pan assembly	1	
20	12210600001504	Under plate	1	
21	12600401002915	Rubber gasket	2	
22	12200202000266	Pipe fixing clamp	2	
23	12210600001508	Expansion tank retaining clip	2	
24	12210600001632	Small water tank fixed plate	1	Optional function parts
25	12225300009063	Small water tank	1	Optional function parts
26	12600701000082	Seal ring (RoHS)	2	Optinal function parts
27	15410600000492	Water Outlet pipe assembly	1	Optional function parts
28	11201007000223	Water Temperature Sensor	1	T1
29	11201007001983	Water Temperature Sensor	1	Twin
30	11201007001982	Water Temperature Sensor	2	Twout
31	11201007000382	Pipe Temperature Sensor	2	T2 T2B

# MSH-80EB

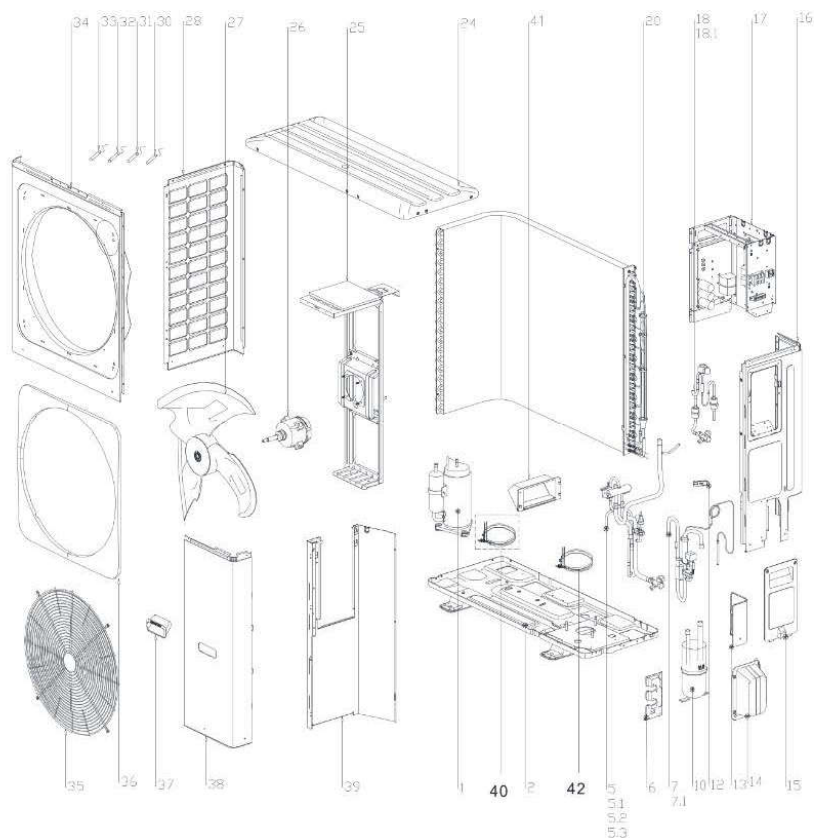
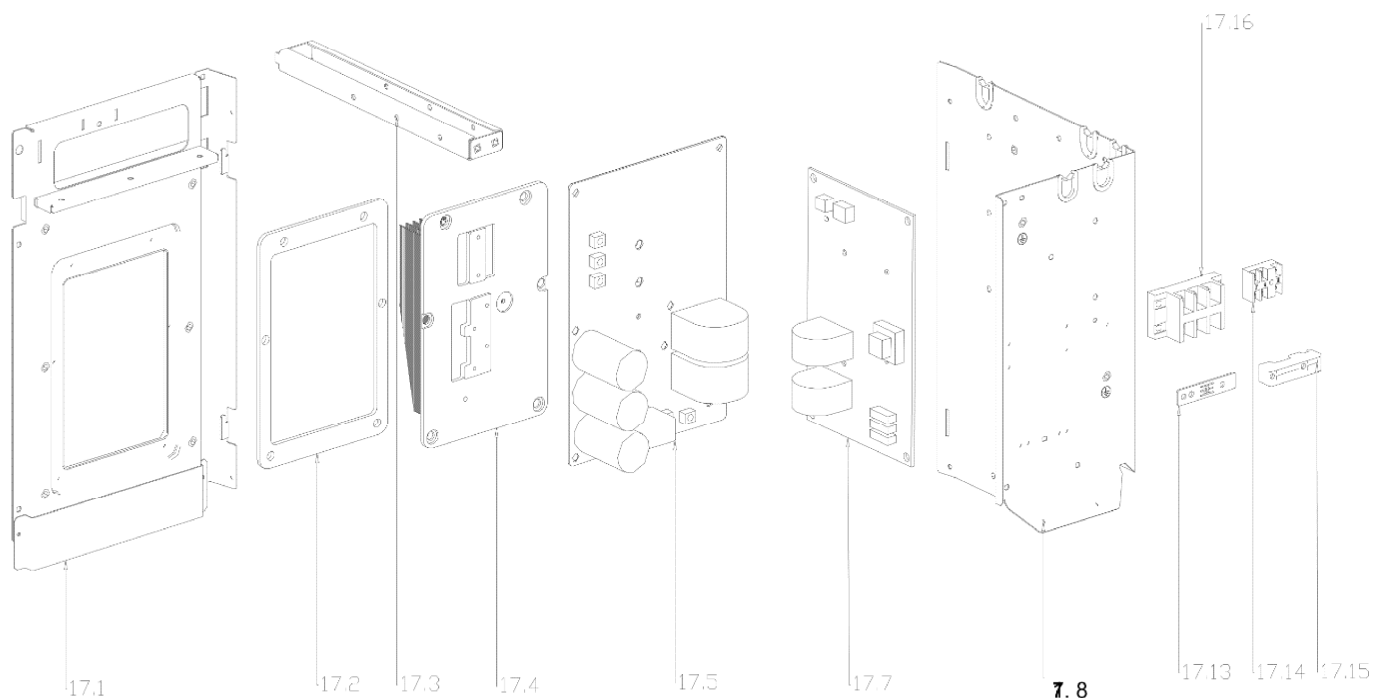

EX_ID	Spare Parts Code	Part Name(EN)	QTY.	Remark
1	11103020005012	DC Inverter Rotary Compressor	1	
2	12227000016164	Chassis part	1	
5	15427000005246	Four-way valve assembly	1	
5.1	15500216000103	4-way valve suite	1	

5.2	11201008000033	Pressure sensor	1	
5.3	17400516000808	Pressure switch	1	
6	12223000012694	Valve plate	1	
7	15427000005245	D unit suction pipe assembly	1	
7.1	17400516000008	Pressure switch	1	
10	15500501001809	Gas-liquid separator	1	
12	12200202000023	Pipe fixing clamp	1	
13	12227000007795	Clapboard	1	
14	12122000029462	Water collector	1	
15	12227000007741	Big handle assembly	1	
16	12227000012342	Rear-Right Side Plate Assembly	1	
17	17223000A07098	E-box assembly	1	
17.1	12227000015799	Radiator support plate	1	
17.2	12627000000646	Seal gasket	1	
17.3	12927000001412	Optional heat exchanger	1	
17.4	12227100007239	Connecting plate assembly	1	
17.5	17125300003905	Module board assembly	1	
17.7	17125300004203	Outdoor main control board assembly	1	
17.8	12227000015800	Electrical appliance mounting plate assembly	1	
17.13	12122000006931	Insulation plate	1	
17.14	17400401000183	Wire joint	1	
17.15	12100303001082	Wire clip	1	
17.16	17400401000073	Wire joint	1	
17.16	17400401000026	Terminal	1	
18	15427000004449	Expansion valve assembly	1	
18.1	15500213001527	Electronic expansion valve suite	1	
20	15827000001670	B unit condenser assembly	1	
24	12227000012341	Top cover assembly	1	
25	12227000012340	Motor bracket I assembly	1	
26	11002015006321	Brushless DC Motor	1	
27	12100105000641	Axial fan	1	
28	12227000007803	Clapboard	1	
30	11201007000039	Room Temperature Sensor	1	T4 : OUTDOOR AMBIENT TEMPERATURE SENSOR
31	11201007002463	Discharge Temperature Sensor	1	Tp : COMP DISCHARGE TEMPERATURE
32	11201007000382	Pipe Temperature Sensor	1	Th : EVAPORATOR INPUT TEMPERATURE
33	11201007000164	Pipe Temperature Sensor	1	T3:CONDENSOR TEMPERATURE SENSOR
34	12227000009453	Right front panel	1	
35	12927000001414	Wind nets	1	
36	12127000001137	Panel	1	
38	12227000015910	Front Right Side Plate Assembly	1	
39	12227000015810	Partition board assembly	1	
40	17402001000259	Chassis electric heating	1	Optional function parts
41	12127000001300	Rainproof cover	1	
42	17402001000339	Compressor electric heater	2	

# MSH-100EB

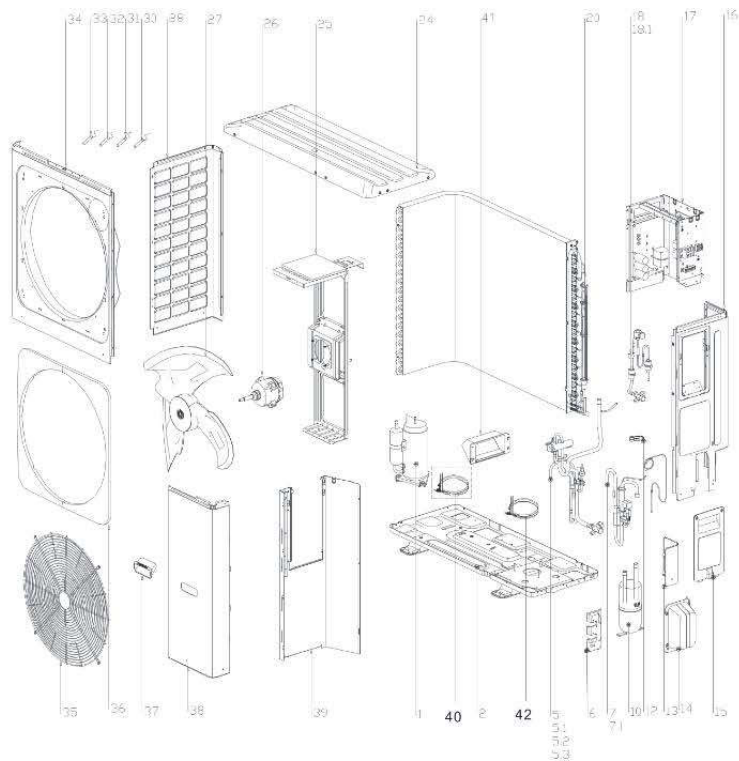
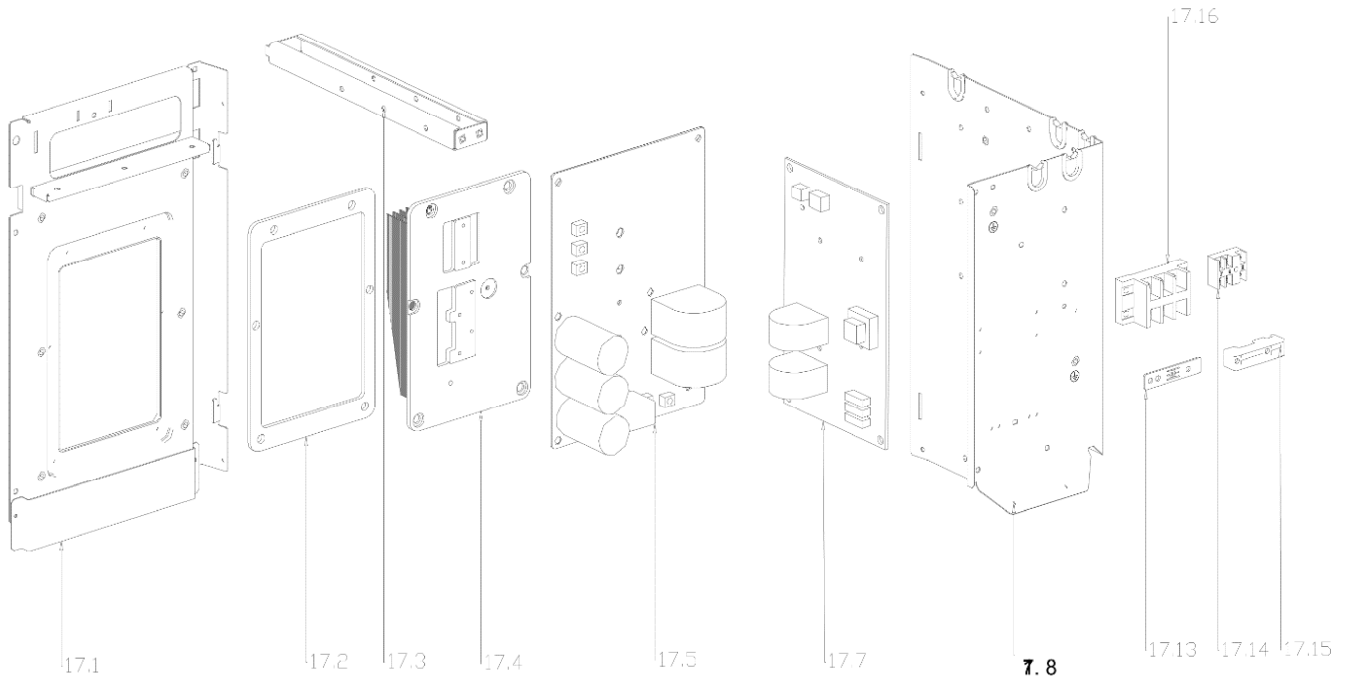

EX_ID	Spare Parts Code	Part Name(EN)	QTY.	Remark
1	11103020005012	DC Inverter Rotary Compressor	1	
2	12227000016164	Chassis part	1	
5	15427000005246	Four-way valve assembly	1	
5.1	15500216000103	4-way valve suite	1	
5.2	11201008000033	Pressure sensor	1	
5.3	17400516000808	Pressure switch	1	
6	12223000012694	Valve plate	1	
7	15427000005245	D unit suction pipe assembly	1	
7.1	17400516000008	Pressure switch	1	
10	15500501001809	Gas-liquid separator	1	
12	12200202000023	Pipe fixing clamp	1	
13	12227000007795	Clapboard	1	
14	12122000029462	Water collector	1	
15	12227000007741	Big handle assembly	1	
16	12227000012342	Rear-Right Side Plate Assembly	1	
17	17223000A07098	E-box assembly	1	
17.1	12227000015799	Radiator support plate	1	
17.2	12627000000646	Seal gasket	1	
17.3	12927000001412	Optional heat exchanger	1	
17.4	12227100007239	Connecting plate assembly	1	
17.5	17125300003905	Module board assembly	1	
17.7	17125300004203	Outdoor main control board assembly	1	
17.8	12227000015800	Electrical appliance mounting plate assembly	1	
17.13	12122000006931	Insulation plate	1	
17.14	17400401000183	Wire joint	1	
17.15	12100303001082	Wire clip	1	
17.16	17400401000073	Wire joint	1	
17.16	17400401000026	Terminal	1	
18	15427000004449	Expansion valve assembly	1	
18.1	15500213001527	Electronic expansion valve suite	1	
20	15827000001670	B unit condenser assembly	1	
24	12227000012341	Top cover assembly	1	
25	12227000012340	Motor bracket I assembly	1	
26	11002015006321	Brushless DC Motor	1	
27	12100105000641	Axial fan	1	
28	12227000007803	Clapboard	1	
30	11201007000039	Room Temperature Sensor	1	T4 : OUTDOOR AMBIENT TEMPERATURE SENSOR
31	11201007002463	Discharge Temperature Sensor	1	Tp : COMP DISCHARGE TEMPERATURE
32	11201007000382	Pipe Temperature Sensor	1	Th : EVAPORATOR INPUT TEMPERATURE
33	11201007000164	Pipe Temperature Sensor	1	T3:CONDENSOR TEMPERATURE SENSOR
34	12227000009453	Right front panel	1	
35	12927000001414	Wind nets	1	
36	12127000001137	Panel	1	

**S-Therm Yukon split series**

38	12227000015910	Front Right Side Plate Assembly	1	
39	12227000015810	Partition board assembly	1	
40	17402001000259	Chassis electric heating	1	Optional function parts
41	12127000001300	Rainproof cover	1	
42	17402001000339	Compressor electric heater	2	

# MSH-100IB-3/9

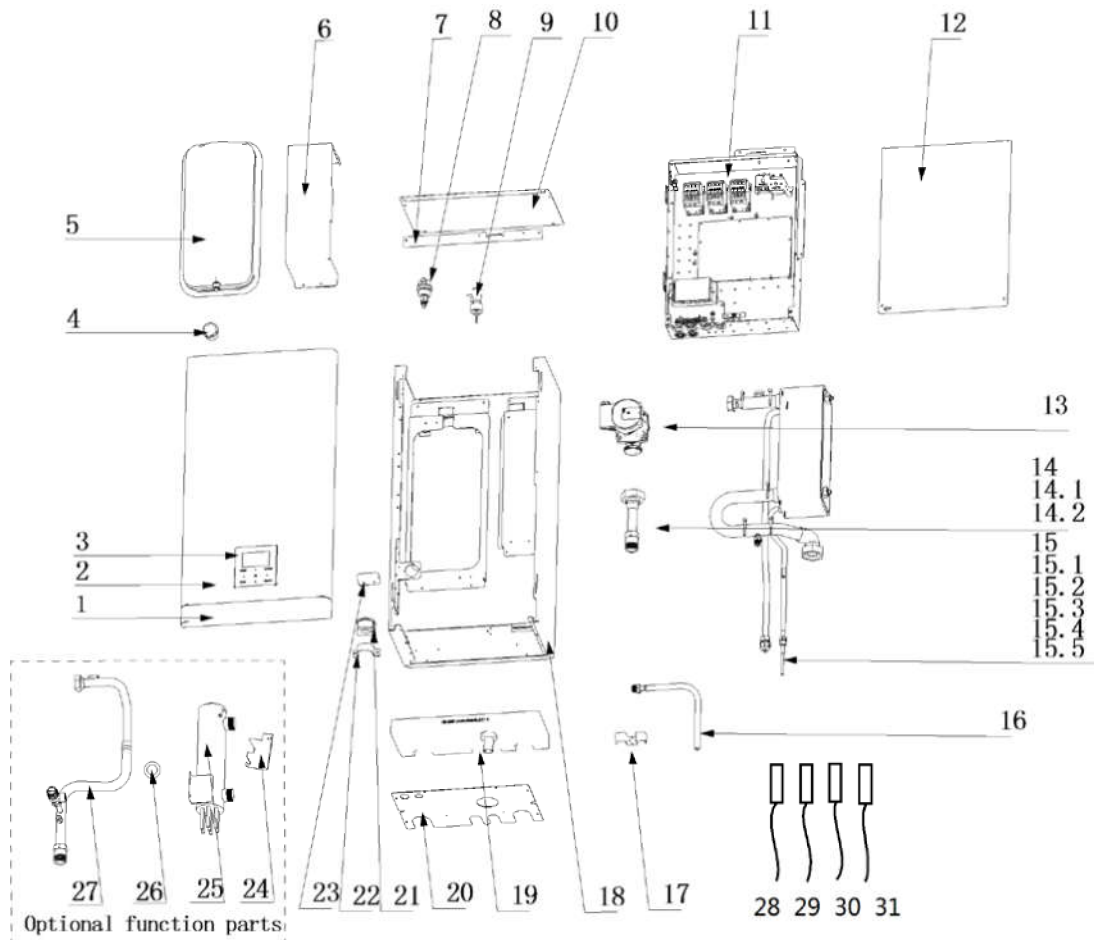

## S-Therm Yukon split series



EX_ID	Spare Parts Code	Part Name(EN)	QTY.	Remark2
1	12110600000129	Decorative plate	1	
2	12210600001518	Panel	1	
2	17317100006817	Wired controller	1	
4	17500501000121	Pressure gauge	1	
5	15500509000107	closed expansion vessels with built in diaphragm	1	
6	12210600001491	Plate heat exchanger fixed plate	1	
7	12210600001515	E-Part box bracket	1	
8	15500211000047	Exhaust valve	1	
9	17400510000474	Water flow switch	1	
10	12210600001506	Top cover	1	
11	17210600A00270	E-part box assembly	1	
11.1	17110600000570	Hydraulic module, Main control board assembly	1	
12	12210600001629	Electric control box cover	1	
13	17400802001733	Shielded pump	1	
14	15410600000433	Water Inlet pipe assembly	1	
14.1	15500303002324	Pipe joint	1	
14.2	15500406000033	Hex nut	1	
15	15710600000265	Plate heat exchanger assembly	1	
15.1	15710600000266	Plate heat exchanger assembly	1	
15.1.1	15700101000977	Plate heat exchanger	1	
15.1.2	15410600000491	Water outlet pipe assembly	1	
15.1.3	15410600000431	Water Inlet pipe assembly	1	
15.1.4	15110600000656	Liquid pipe assembly	1	
15.1.5	15110600000652	Gas pipe assembly	1	
16	12100509000532	Connecting hose	1	
17	12210600001513	Refrigerant pipe fixed plate	1	
18	12210600001493	Base assembly	1	
19	12210600001517	Drainage pan assembly	1	
20	12210600001504	Under plate	1	
21	12600401002915	Rubber gasket	2	
22	12200202000266	Pipe fixing clamp	2	
23	12210600001508	Expansion tank retaining clip	2	
24	12210600001632	Small water tank fixed plate	1	Optional function parts
25	12225300009065	Small water tank	1	Optional function parts
26	12600701000082	Seal ring (RoHS)	2	Optinal function parts
27	15410600000492	Water Outlet pipe assembly	1	Optional function parts
28	11201007000223	Water Temperature Sensor	1	T1
29	11201007001983	Water Temperature Sensor	1	Twin
30	11201007001982	Water Temperature Sensor	2	Twout
31	11201007000382	Pipe Temperature Sensor	2	T2 T2B

# MSH-120EB-3

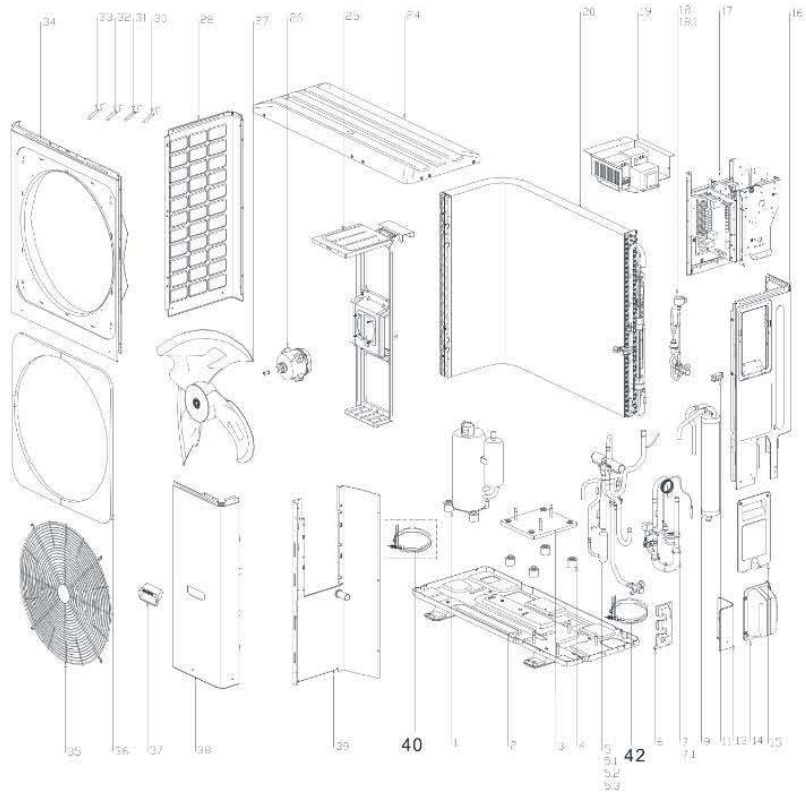
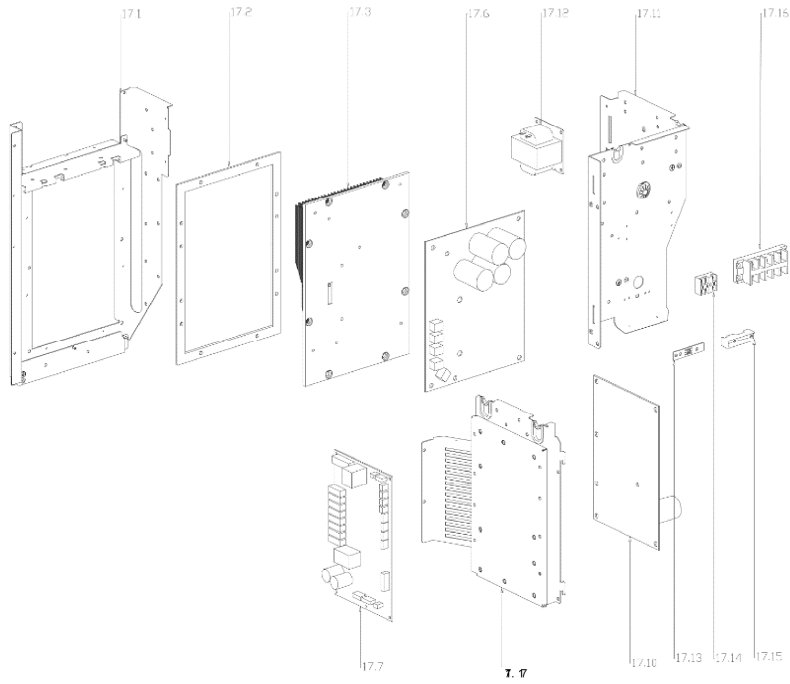

# S-Therm Yukon split series



EX_ID	Spare Parts Code	Part Name(EN)	QTY.	Remark2
1	11103020006960	DC Inverter Rotary Compressor	1	
2	12227000016163	Chassis part	1	
3	12227000012450	Compressor, supporting plate	1	
4	12627000000726	Compressor, damping pad	4	
5	15427000005244	Four-way valve assembly	1	
5.1	15500216001041	four-way valve assembly	1	
5.2	11201008000033	Pressure sensor	1	
5.3	17400516000788	Pressure controller	1	
6	12223000012694	Valve plate	1	
7	15427000004528	D unit suction pipe assembly	1	
7.1	17400516000008	Pressure switch	1	
9	15425300003080	Liquid storage tank assembly	1	
11	12600401000158	rubber base	1	
13	12227000007795	Clapboard	1	
14	12122000029462	Water collector	1	
15	12227000007741	Big handle assembly	1	
16	12227000012342	Rear-Right Side Plate Assembly	1	
17	17223000A07100	E-box assembly	1	
17.1	12227000015796	Radiator support plate	1	
17.2	12627000000647	Seal gasket	1	
17.3	12927000001415	Optional heat exchanger	1	
17.6	17127000008876	Compressor module board assembly	1	
17.7	17127400000355	DC inverter aqua mini chiller - Main control board assembly	1	
17.10	17127000008540	Filter board assembly	1	
17.11	12225300011533	Terminal mounting board assembly	1	
17.12	17400306000163	Reactance	1	
17.13	12122000006931	Insulation plate	1	
17.14	17400401000183	Wire joint	1	
17.15	12100303000123	Tension clip	1	
17.16	17400401000026	Terminal	1	
17.16	17400401000049	Wire joint	1	
17.17	12223000015292	Electrical appliance mounting plate assembly	1	
18	15427000004529	Expansion valve assembly	1	
18.1	15500213001565	Electronic expansion valve suite	1	
19	17225300003000	Inductance box assembly	1	
20	15827000001708	B unit condenser assembly	1	
24	12227000012341	Top cover assembly	1	
25	12227000012449	Motor bracket I assembly	1	
26	11002015006321	Brushless DC Motor	1	
27	12100105000641	Axial fan	1	
28	12227000007803	Clapboard	1	

**S-Therm Yukon split series**

30	11201007000039	Room Temperature Sensor	1	T4 : OUTDOOR AMBIENT TEMPERATURE SENSOR
31	11201007002463	Discharge Temperature Sensor	1	Tp : COMP DISCHARGE TEMPERATURE
32	11201007000382	Pipe Temperature Sensor	1	Th : EVAPORATOR INPUT TEMPERATURE
33	11201007000164	Pipe Temperature Sensor	1	T3:CONDENSOR TEMPERATURE SENSOR
34	12227000009453	Right front panel	1	
35	12927000001414	Wind nets	1	
36	12127000001137	Panel	1	
38	12227000015910	Front Right Side Plate Assembly	1	
39	12227000015803	Partition board assembly	1	
40	17402001000259	Chassis electric heating	1	Optional function parts
42	17402001000539	Compressor electric heater	1	

# MSH-140EB-3

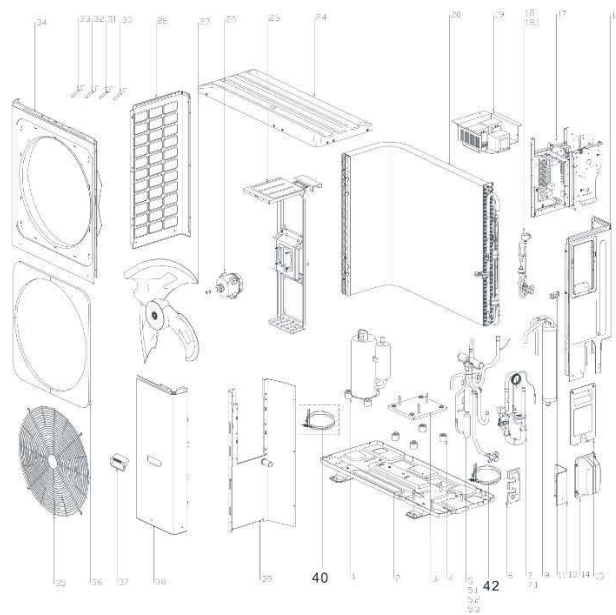
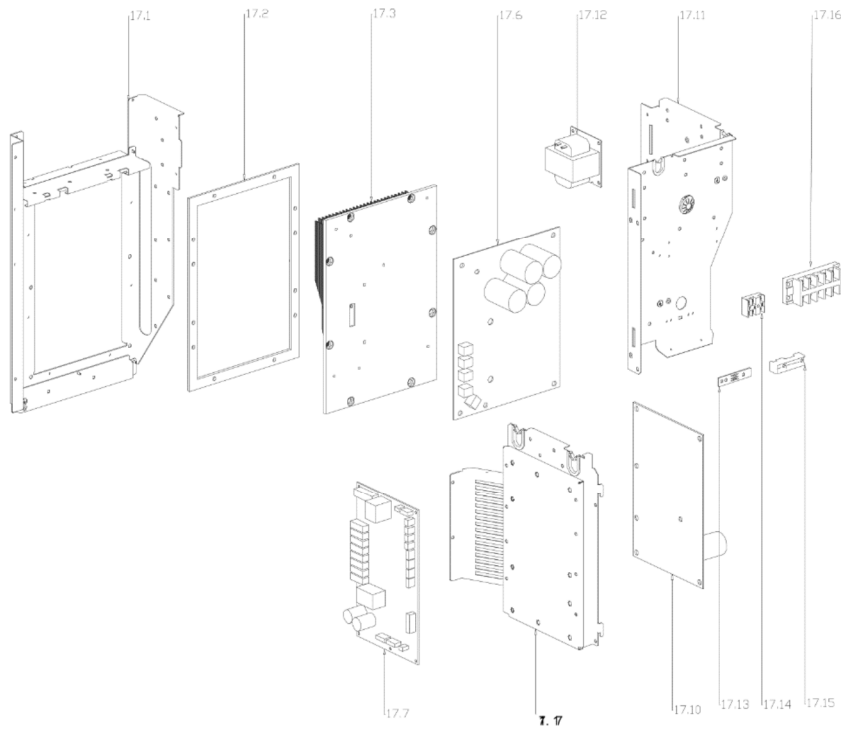

<b>10</b>	<b>Spare Parts Code</b>	<b>Part Name(EN)</b>	<b>QTY.</b>	<b>Remark2</b>
1	11103020006960	DC Inverter Rotary Compressor	1	
2	12227000016163	Chassis part	1	
3	12227000012450	Compressor, supporting plate	1	
4	12627000000726	Compressor, damping pad	4	
5	15427000005244	Four-way valve assembly	1	
5.1	15500216001041	four-way valve assembly	1	
5.2	11201008000033	Pressure sensor	1	
5.3	17400516000788	Pressure controller	1	
6	12223000012694	Valve plate	1	
7	15427000004528	D unit suction pipe assembly	1	
7.1	17400516000008	Pressure switch	1	
9	15425300003080	Liquid storage tank assembly	1	
11	12600401000158	rubber base	1	
13	12227000007795	Clapboard	1	
14	12122000029462	Water collector	1	
15	12227000007741	Big handle assembly	1	
16	12227000012342	Rear-Right Side Plate Assembly	1	
17	17223000A07100	E-box assembly	1	
17.1	12227000015796	Radiator support plate	1	
17.2	12627000000647	Seal gasket	1	
17.3	12927000001415	Optional heat exchanger	1	
17.6	17127000008876	Compressor module board assembly	1	
17.7	17127400000355	DC inverter aqua mini chiller - Main control board assembly	1	
17.10	17127000008540	Filter board assembly	1	
17.11	12225300011533	Terminal mounting board assembly	1	
17.12	17400306000163	Reactance	1	
17.13	12122000006931	Insulation plate	1	
17.14	17400401000183	Wire joint	1	
17.15	12100303000123	Tension clip	1	
17.16	17400401000026	Terminal	1	
17.16	17400401000049	Wire joint	1	
17.17	12223000015292	Electrical appliance mounting plate assembly	1	
18	15427000004529	Expansion valve assembly	1	
18.1	15500213001565	Electronic expansion valve suite	1	
19	17225300003000	Inductance box assembly	1	
20	15827000001708	B unit condenser assembly	1	
24	12227000012341	Top cover assembly	1	
25	12227000012449	Motor bracket I assembly	1	
26	11002015006321	Brushless DC Motor	1	
27	12100105000641	Axial fan	1	

**S-Therm Yukon split series**

28	12227000007803	Clapboard	1	
30	11201007000039	Room Temperature Sensor	1	T4 : OUTDOOR AMBIENT TEMPERATURE SENSOR
31	11201007002463	Discharge Temperature Sensor	1	Tp : COMP DISCHARGE TEMPERATURE
32	11201007000382	Pipe Temperature Sensor	1	Th : EVAPORATOR INPUT TEMPERATURE
33	11201007000164	Pipe Temperature Sensor	1	T3:CONDENSOR TEMPERATURE SENSOR
34	12227000009453	Right front panel	1	
35	12927000001414	Wind nets	1	
36	12127000001137	Panel	1	
38	12227000015910	Front Right Side Plate Assembly	1	
39	12227000015803	Partition board assembly	1	
40	17402001000259	Chassis electric heating	1	Optional function parts
42	17402001000539	Compressor electric heater	1	

# MSH-160EB-3

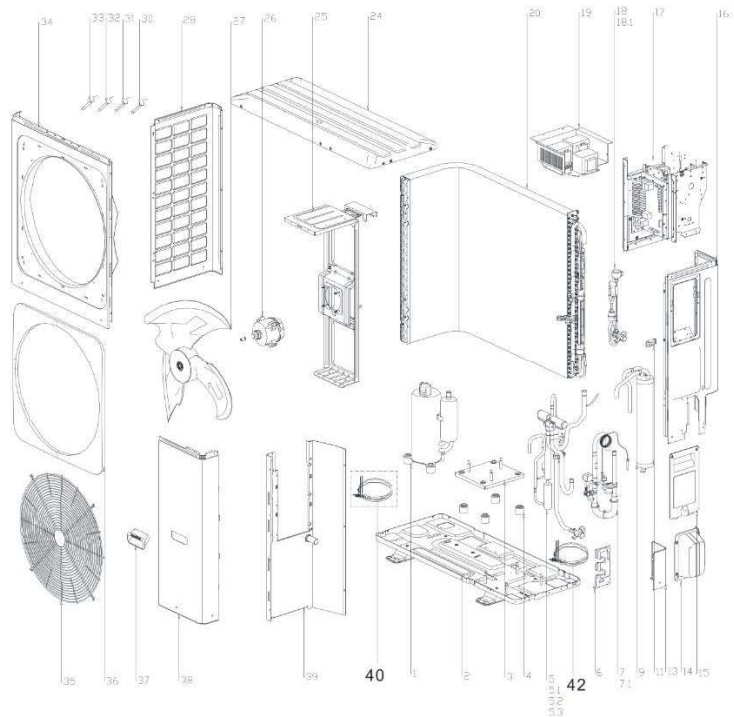
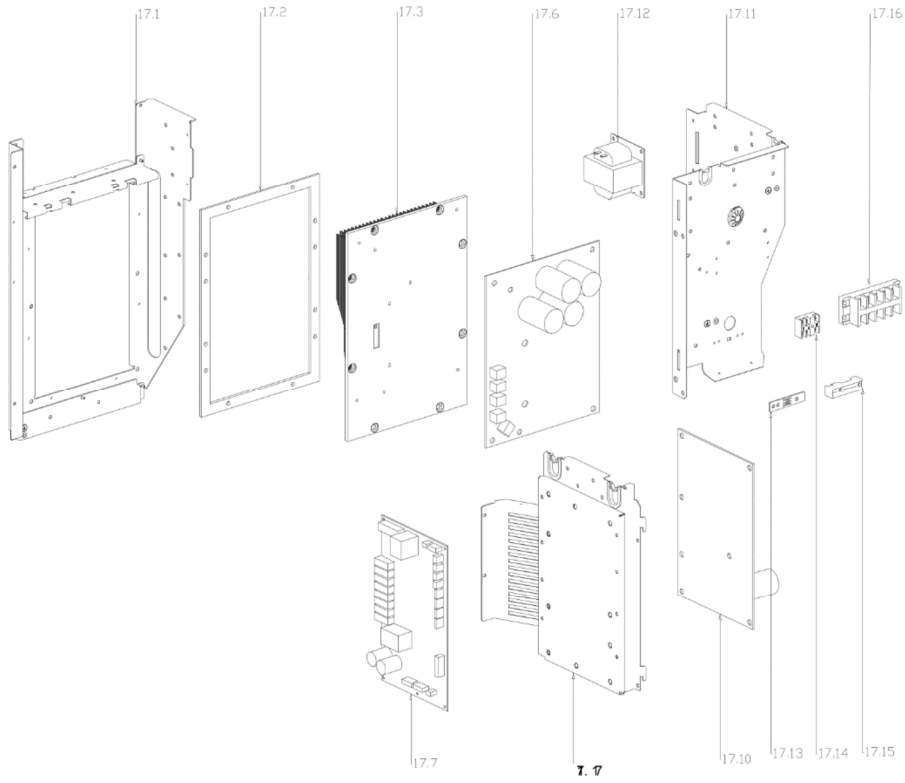

S-Therm Yukon split series



EX_ID	Spare Parts Code	Part Name(EN)	QTY.	Remark2
1	11103020006960	DC Inverter Rotary Compressor	1	
2	12227000016163	Chassis part	1	
3	12227000012450	Compressor, supporting plate	1	
4	12627000000726	Compressor, damping pad	4	
5	15427000005244	Four-way valve assembly	1	
5.1	15500216001041	four-way valve assembly	1	
5.2	11201008000033	Pressure sensor	1	
5.3	17400516000788	Pressure controller	1	
6	12223000012694	Valve plate	1	
7	15427000004528	D unit suction pipe assembly	1	
7.1	17400516000008	Pressure switch	1	
9	15425300003080	Liquid storage tank assembly	1	
11	12600401000158	rubber base	1	
13	12227000007795	Clapboard	1	
14	12122000029462	Water collector	1	
15	12227000007741	Big handle assembly	1	
16	12227000012342	Rear-Right Side Plate Assembly	1	
17	17223000A07100	E-box assembly	1	
17.1	12227000015796	Radiator support plate	1	
17.2	12627000000647	Seal gasket	1	
17.3	12927000001415	Optional heat exchanger	1	
17.6	17127000008876	Compressor module board assembly	1	
17.7	17127400000355	DC inverter aqua mini chiller - Main control board assembly	1	
17.10	17127000008540	Filter board assembly	1	
17.11	12225300011533	Terminal mounting board assembly	1	
17.12	17400306000163	Reactance	1	
17.13	12122000006931	Insulation plate	1	
17.14	17400401000183	Wire joint	1	
17.15	12100303000123	Tension clip	1	
17.16	17400401000026	Terminal	1	
17.16	17400401000049	Wire joint	1	
17.17	12223000015292	Electrical appliance mounting plate assembly	1	
18	15427000004529	Expansion valve assembly	1	
18.1	15500213001565	Electronic expansion valve suite	1	
19	17225300003000	Inductance box assembly	1	
20	15827000001708	B unit condenser assembly	1	
24	12227000012341	Top cover assembly	1	
25	12227000012449	Motor bracket I assembly	1	
26	11002015006321	Brushless DC Motor	1	

27	12100105000641	Axial fan	1	
28	12227000007803	Clapboard	1	
30	11201007000039	Room Temperature Sensor	1	T4 : OUTDOOR AMBIENT TEMPERATURE SENSOR
31	11201007002463	Discharge Temperature Sensor	1	Tp : COMP DISCHARGE TEMPERATURE
32	11201007000382	Pipe Temperature Sensor	1	Th : EVAPORATOR INPUT TEMPERATURE
33	11201007000164	Pipe Temperature Sensor	1	T3:CONDENSOR TEMPERATURE SENSOR
34	12227000009453	Right front panel	1	
35	12927000001414	Wind nets	1	
36	12127000001137	Panel	1	
38	12227000015910	Front Right Side Plate Assembly	1	
39	12227000015803	Partition board assembly	1	
40	17402001000259	Chassis electric heating	1	Optional function parts
42	17402001000539	Compressor electric heater	1	

# MSH-160IB-3/9

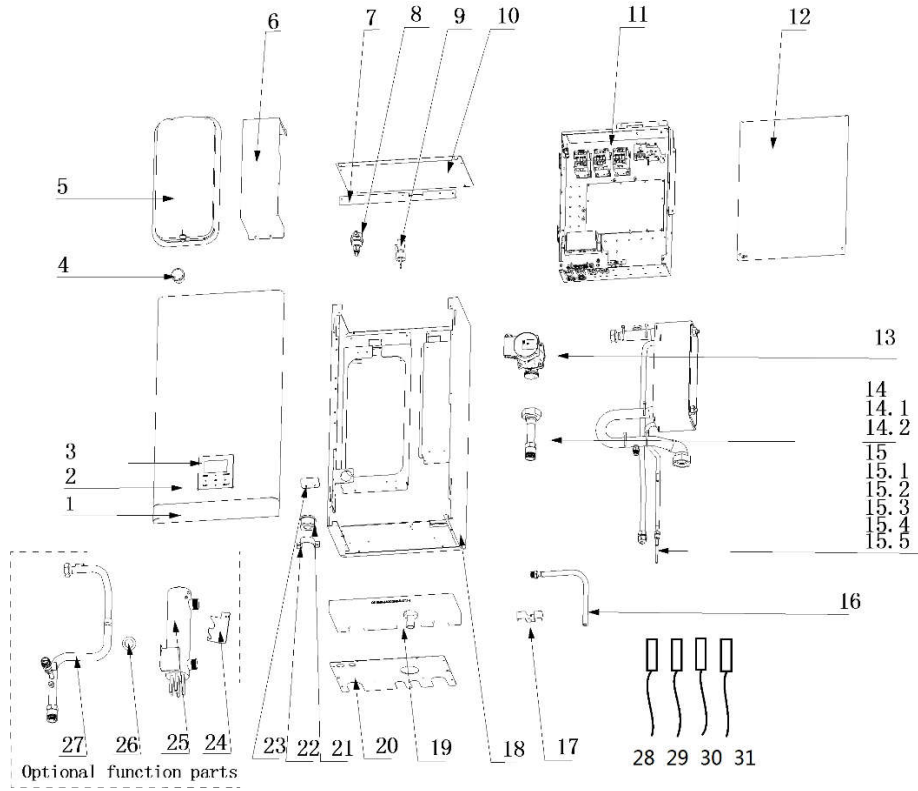

<b>EX_ID</b>	<b>Spare Parts Code</b>	<b>Part Name(EN)</b>	<b>QTY.</b>	<b>Remark2</b>
1	1211060000129	Decorative plate	1	
2	12210600001518	Panel	1	
2	17317100A35072	Wired controller	1	
4	17500501000121	Pressure gauge	1	
5	15500509000107	closed expansion vessels with built in diaphragm	1	
6	12210600001489	Plate heat exchanger fixed plate	1	
7	12210600001515	E-Part box bracket	1	
8	15500211000047	Exhaust valve	1	
9	17400510000007	Water flow switch	1	
10	12210600001506	Top cover	1	
11	17210600A00270	E-part box assembly	1	
11.1	17110600000570	Hydraulic module, Main control board assembly	1	
12	12210600001629	Electric control box cover	1	
13	17400802001733	Shielded pump	1	
14	15410600000433	Water Inlet pipe assembly	1	
14.1	15500303002324	Pipe joint	1	
14.2	15500406000033	Hex nut	1	
15	15710600000261	Plate heat exchanger assembly	1	
15.1	15710600000262	Plate heat exchanger assembly	1	
15.1.1	15700101000976	Plate heat exchanger	1	
15.1.2	15410600000491	Water outlet pipe assembly	1	
15.1.3	15410600000431	Water Inlet pipe assembly	1	
15.1.4	15110600000656	Liquid pipe assembly	1	
15.1.5	15110600000652	Gas pipe assembly	1	
16	12100509000532	Connecting hose	1	
17	12210600001513	Refrigerant pipe fixed plate	1	
18	12210600001493	Base assembly	1	
19	12210600001517	Drainage pan assembly	1	
20	12210600001504	Under plate	1	
21	12600401002915	Rubber gasket	2	
22	12200202000266	Pipe fixing clamp	2	
23	12210600001508	Expansion tank retaining clip	2	
24	12210600001632	Small water tank fixed plate	1	Optional function parts
25	12225300009065	Small water tank	1	Optional function parts
26	12600701000082	Seal ring (RoHS)	2	Optinal function parts
27	15410600000492	Water Outlet pipe assembly	1	Optional function parts
28	11201007000223	Water Temperature Sensor	1	T1

### S-Therm Yukon split series

29	11201007001983	Water Temperature Sensor	1	Twin
30	11201007001982	Water Temperature Sensor	2	Twout
31	11201007000382	Pipe Temperature Sensor	2	T2 T2B

## NOTE CONCERNING PROTECTION OF ENVIRONMENT



This product must not be disposed of via normal household waste after its service life, but must be taken to a collection station for the recycling of electrical and electronic devices. The symbol on the product, the operating instructions or the packaging indicate such disposal procedures. The materials are recyclable in accordance with their respective symbols. By means of re-use, material recycling or any other form of recycling old appliances you are making an important contribution to the protection of our environment. Please ask your local council where your nearest disposal station is located.

## INFORMATION CONCERNING USED REFRIGERANT MEDIUM

This unit is containing fluorinated gases included in the Kyoto protocol.  
The maintenance and the liquidation must be carried out by qualified personnel.

Type of refrigerant: R32

The quantity of the refrigerant: Please see the unit label.

The value GWP: 675 (1 kg R32 = 0,675 t CO<sub>2</sub> eq)

GWP = Global Warming Potential



Appliance filled with flammable gas R32.

In case of quality problem or other please contact your local supplier or authorized service center.

**Emergency number: 112**

## PRODUCER

SINCLAIR CORPORATION Ltd.

16 Great Queen Street

WC2B 5AH London

United Kingdom

[www.sinclair-world.com](http://www.sinclair-world.com)

This product was manufactured in China (Made in China).

## REPRESENTATIVE

SINCLAIR Global Group s.r.o.

Purkynova 45

612 00 Brno

Czech Republic

## TECHNICAL SUPPORT

SINCLAIR Global Group s.r.o.

Purkynova 45

612 00 Brno

Czech Republic

Tel.: +420 800 100 285 | Fax: +420 541 590 124

[www.sinclair-solutions.com](http://www.sinclair-solutions.com) | [info@sinclair-solutions.com](mailto:info@sinclair-solutions.com)



