

**SERVICE MANUAL**

# ARCTIC SERIE

**ASH-13AIA PT, ASH-18AIA PT**



## Table of Contents

|                                                              |    |
|--------------------------------------------------------------|----|
| <b>Part I : Technical Information</b> .....                  | 1  |
| <b>1. Summary</b> .....                                      | 1  |
| <b>2. Specifications</b> .....                               | 2  |
| 2.1 Specification Sheet.....                                 | 2  |
| 2.2 Operation Characteristic Curve.....                      | 8  |
| 2.3 Capacity Variation Ratio According to Temperature.....   | 9  |
| 2.4 Cooling and Heating Data Sheet in Rated Frequency.....   | 10 |
| 2.5 Noise Curve.....                                         | 10 |
| <b>3. Outline Dimension Diagram</b> .....                    | 11 |
| 3.1 Indoor Unit.....                                         | 11 |
| 3.2 Outdoor Unit.....                                        | 12 |
| <b>4. Refrigerant System Diagram</b> .....                   | 13 |
| <b>5. Electrical Part</b> .....                              | 14 |
| 5.1 Wiring Diagram.....                                      | 14 |
| 5.2 PCB Printed Diagram.....                                 | 17 |
| <b>6. Function and Control</b> .....                         | 21 |
| 6.1 Remote Controller Introduction.....                      | 21 |
| 6.2 Operation of Smart Control (Smart Phone, Tablet PC)..... | 26 |
| 6.3 Brief Description of Modes and Functions.....            | 31 |
| <b>Part II : Installation and Maintenance</b> .....          | 40 |
| <b>7. Notes for Installation and Maintenance</b> .....       | 40 |
| <b>8. Installation</b> .....                                 | 42 |
| 8.1 Installation Dimension Diagram.....                      | 42 |
| 8.2 Installation Parts-checking.....                         | 44 |
| 8.3 Selection of Installation Location.....                  | 44 |
| 8.4 Electric Connection Requirement.....                     | 44 |
| 8.5 Installation of Indoor Unit.....                         | 44 |
| 8.6 Installation of Outdoor Unit.....                        | 47 |
| 8.7 Vacuum Pumping and Leak Detection.....                   | 48 |
| 8.8 Check after Installation and Test Operation.....         | 48 |

|                                                             |     |
|-------------------------------------------------------------|-----|
| <b>9. Maintenance</b> .....                                 | 49  |
| 9.1 Error Code List .....                                   | 49  |
| 9.2 Troubleshooting for Main Malfunction .....              | 56  |
| 9.3 Troubleshooting for Normal Malfunction.....             | 80  |
| <b>10. Exploded View and Parts List</b> .....               | 82  |
| 10.1 Indoor Unit.....                                       | 82  |
| 10.2 Outdoor Unit.....                                      | 86  |
| <b>11. Removal Procedure</b> .....                          | 90  |
| 11.1 Removal Procedure of Indoor Unit .....                 | 90  |
| 11.2 Removal Procedure of Outdoor Unit .....                | 99  |
| <b>Appendix:</b> .....                                      | 110 |
| Appendix 1: Reference Sheet of Celsius and Fahrenheit ..... | 110 |
| Appendix 2: Configuration of Connection Pipe.....           | 110 |
| Appendix 3: Pipe Expanding Method .....                     | 111 |
| Appendix 4: List of Resistance for Temperature Sensor ..... | 112 |

# Part I : Technical Information

---

## 1. Summary

**Indoor Unit:**

ASH-13AIA PT  
ASH-18AIA PT

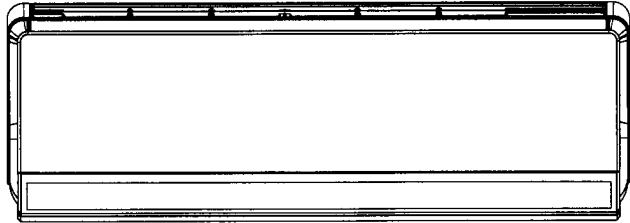

**Outdoor Unit:**

ASH-13AIA PT

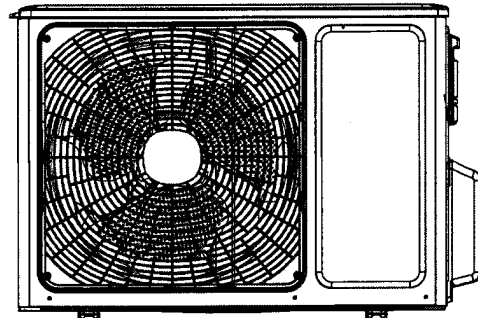

ASH-18AIA PT

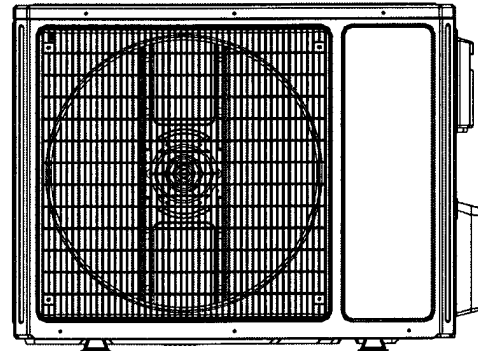

**Remote Controller:**

SAA1FB1



## 2. Specifications

### 2.1 Specification Sheet

| Parameter                           | Unit                                          | Value                                    |
|-------------------------------------|-----------------------------------------------|------------------------------------------|
| Model                               |                                               | ASH-13AIA PT                             |
| Power Supply                        | Rated Voltage                                 | V~ 220-240                               |
|                                     | Rated Frequency                               | Hz 50                                    |
|                                     | Phases                                        | 1                                        |
| Power Supply Mode                   |                                               | Outdoor                                  |
| Cooling Capacity                    | W                                             | 3500                                     |
| Heating Capacity                    | W                                             | 3600                                     |
| Cooling Power Input                 | W                                             | 920                                      |
| Heating Power Input                 | W                                             | 970                                      |
| Cooling Power Current               | A                                             | 4.1                                      |
| Heating Power Current               | A                                             | 4.2                                      |
| Rated Input                         | W                                             | 1680                                     |
| Rated Current                       | A                                             | 6.8                                      |
| Air Flow Volume (SH/H/MH/M/ML/L/SL) | m <sup>3</sup> /h                             | 720/550/490/420/370/320/290              |
| Dehumidifying Volume                | L/h                                           | 1.4                                      |
| EER                                 | W/W                                           | 3.80                                     |
| COP                                 | W/W                                           | 3.71                                     |
| SEER                                |                                               | 7.0                                      |
| SCOP                                |                                               | 4.6                                      |
| Application Area                    | m <sup>2</sup>                                | 16-24                                    |
| Indoor Unit                         | Model                                         | ASH-13AIA PT                             |
|                                     | Fan Type                                      | Cross-flow                               |
|                                     | Diameter Length(DXL)                          | mm $\Phi$ 92X616                         |
|                                     | Fan Motor Cooling Speed (SH/H/MH/M/ML/L/SL/Q) | r/min 1400/1185/1053/920/829/741/650/550 |
|                                     | Fan Motor Heating Speed (SH/H/MH/M/ML/L/SL/Q) | r/min 1400/1185/1119/1053/958/870/842/-  |
|                                     | Output of Fan Motor                           | W 10                                     |
|                                     | Fan Motor RLA                                 | A 0.3                                    |
|                                     | Fan Motor Capacitor                           | $\mu$ F /                                |
|                                     | Input of Heater                               | W /                                      |
|                                     | Evaporator Form                               | Aluminum Fin-copper Tube                 |
|                                     | Pipe Diameter                                 | mm $\Phi$ 7                              |
|                                     | Row-fin Gap                                   | mm 2-1.5                                 |
|                                     | Coil Length (LXD <sub>X</sub> W)              | mm 623X25.4X304.8                        |
|                                     | Swing Motor Model                             | MP24HD                                   |
|                                     | Output of Swing Motor                         | W 1.5                                    |
|                                     | Fuse                                          | A 3.15                                   |
|                                     | Sound Pressure Level (SH/H/MH/M/ML/L/SL)      | dB (A) 43/38/36/34/31/23/20              |
|                                     | Sound Power Level (SH/H/MH/M/ML/L/SL)         | dB (A) 57/51/49/47/44/36/33              |
|                                     | Dimension (WXHXD)                             | mm 860X305X170                           |
|                                     | Dimension of Carton Box (LXWXH)               | mm 932X385X280                           |
|                                     | Dimension of Package (LXWXH)                  | mm 935X388X295                           |
|                                     | Net Weight                                    | kg 12.5                                  |
|                                     | Gross Weight                                  | kg 15                                    |

|                                                    |                                                                 |                   |                                  |
|----------------------------------------------------|-----------------------------------------------------------------|-------------------|----------------------------------|
| Outdoor Unit                                       | Model                                                           |                   | ASH-13AIA PT                     |
|                                                    | Compressor Manufacturer/Trademark                               |                   | ZHUHAI LANDA COMPRESSOR CO.,LTD. |
|                                                    | Compressor Model                                                |                   | QXAT-B121zE070                   |
|                                                    | Compressor Oil                                                  |                   | FV50S                            |
|                                                    | Compressor Type                                                 |                   | Rotary                           |
|                                                    | L.R.A.                                                          | A                 | 35                               |
|                                                    | Compressor RLA                                                  | A                 | 6.7                              |
|                                                    | Compressor Power Input                                          | W                 | 1430                             |
|                                                    | Overload Protector                                              |                   | 1NT11L-6233                      |
|                                                    | Throttling Method                                               |                   | Electron expansion valve         |
|                                                    | Operation temp                                                  | °C                | 16~30                            |
|                                                    | Ambient temp (cooling)                                          | °C                | -18~54                           |
|                                                    | Ambient temp (heating)                                          | °C                | -30~24                           |
|                                                    | Condenser Form                                                  |                   | Aluminum Fin-copper Tube         |
|                                                    | Pipe Diameter                                                   | mm                | Φ7                               |
|                                                    | Rows-fin Gap                                                    | mm                | 2.5-1.4                          |
|                                                    | Coil Length (LXDXW)                                             | mm                | 763X57X550                       |
|                                                    | Fan Motor Speed                                                 | rpm               | 780                              |
|                                                    | Output of Fan Motor                                             | W                 | 30                               |
|                                                    | Fan Motor RLA                                                   | A                 | 0.24                             |
|                                                    | Fan Motor Capacitor                                             | μF                | /                                |
|                                                    | Air Flow Volume of Outdoor Unit                                 | m <sup>3</sup> /h | 2400                             |
|                                                    | Fan Type                                                        |                   | Axial-flow                       |
|                                                    | Fan Diameter                                                    | mm                | Φ438                             |
|                                                    | Defrosting Method                                               |                   | Automatic Defrosting             |
|                                                    | Climate Type                                                    |                   | T1                               |
|                                                    | Isolation                                                       |                   | I                                |
|                                                    | Moisture Protection                                             |                   | IP24                             |
|                                                    | Permissible Excessive Operating Pressure for the Discharge Side | MPa               | 4.3                              |
|                                                    | Permissible Excessive Operating Pressure for the Suction Side   | MPa               | 2.5                              |
|                                                    | Sound Pressure Level (H/M/L)                                    | dB (A)            | 50/-/-                           |
|                                                    | Sound Power Level (H/M/L)                                       | dB (A)            | 60/-/-                           |
| Dimension (WXHxD)                                  | mm                                                              | 899X596X378       |                                  |
| Dimension of Carton Box (LXWXH)                    | mm                                                              | 945X417X630       |                                  |
| Dimension of Package (LXWXH)                       | mm                                                              | 948X420X645       |                                  |
| Net Weight                                         | kg                                                              | 43                |                                  |
| Gross Weight                                       | kg                                                              | 46                |                                  |
| Refrigerant                                        |                                                                 | R410A             |                                  |
| Refrigerant Charge                                 | kg                                                              | 1.3               |                                  |
| Connection Pipe                                    | Length                                                          | m                 | 5                                |
|                                                    | Gas Additional Charge                                           | g/m               | 20                               |
|                                                    | Outer Diameter Liquid Pipe                                      | mm                | Φ6                               |
|                                                    | Outer Diameter Gas Pipe                                         | mm                | Φ12                              |
|                                                    | Max Distance Height                                             | m                 | 10                               |
|                                                    | Max Distance Length                                             | m                 | 20                               |
| Note: The connection pipe applies metric diameter. |                                                                 |                   |                                  |

The above data is subject to change without notice; please refer to the nameplate of the unit.

| Parameter                           | Unit                                          | Value                       |                                    |
|-------------------------------------|-----------------------------------------------|-----------------------------|------------------------------------|
| Model                               |                                               | ASH-18AIA PT                |                                    |
| Power Supply                        | Rated Voltage                                 | V~ 220-240                  |                                    |
|                                     | Rated Frequency                               | Hz 50                       |                                    |
|                                     | Phases                                        | 1                           |                                    |
| Power Supply Mode                   |                                               | Outdoor                     |                                    |
| Cooling Capacity                    | W                                             | 5275                        |                                    |
| Heating Capacity                    | W                                             | 5275                        |                                    |
| Cooling Power Input                 | W                                             | 1600                        |                                    |
| Heating Power Input                 | W                                             | 1420                        |                                    |
| Cooling Power Current               | A                                             | 7.1                         |                                    |
| Heating Power Current               | A                                             | 6.2                         |                                    |
| Rated Input                         | W                                             | 2400                        |                                    |
| Rated Current                       | A                                             | 9.1                         |                                    |
| Air Flow Volume (SH/H/MH/M/ML/L/SL) | m <sup>3</sup> /h                             | 850/750/650/600/500/400/340 |                                    |
| Dehumidifying Volume                | L/h                                           | 1.8                         |                                    |
| EER                                 | W/W                                           | 3.30                        |                                    |
| COP                                 | W/W                                           | 3.72                        |                                    |
| SEER                                |                                               | 6.1                         |                                    |
| SCOP                                |                                               | 4.0                         |                                    |
| Application Area                    | m <sup>2</sup>                                | 23-34                       |                                    |
| Indoor Unit                         | Model                                         | ASH-18AIA PT                |                                    |
|                                     | Fan Type                                      | Cross-flow                  |                                    |
|                                     | Diameter Length(DXL)                          | mm                          | Φ107X699                           |
|                                     | Fan Motor Cooling Speed (SH/H/MH/M/ML/L/SL/Q) | r/min                       | 1350/1150/1050/930/800/700/650/600 |
|                                     | Fan Motor Heating Speed (SH/H/MH/M/ML/L/SL/Q) | r/min                       | 1400/1200/1100/1000/900/800/750/-  |
|                                     | Output of Fan Motor                           | W                           | 20                                 |
|                                     | Fan Motor RLA                                 | A                           | 0.44                               |
|                                     | Fan Motor Capacitor                           | μF                          | /                                  |
|                                     | Input of Heater                               | W                           | /                                  |
|                                     | Evaporator Form                               |                             | Aluminum Fin-copper Tube           |
|                                     | Pipe Diameter                                 | mm                          | Φ7                                 |
|                                     | Row-fin Gap                                   | mm                          | 2-1.5                              |
|                                     | Coil Length (LXD <sub>X</sub> W)              | mm                          | 706X25.4X303.8                     |
|                                     | Swing Motor Model                             |                             | MP24AQ                             |
|                                     | Output of Swing Motor                         | W                           | 1.5                                |
|                                     | Fuse                                          | A                           | 3.15                               |
|                                     | Sound Pressure Level (SH/H/M/L/SL)            | dB (A)                      | 46/42/40/36/33/25/22               |
|                                     | Sound Power Level (SH/H/M/L/SL)               | dB (A)                      | 58/54/52/48/45/37/34               |
|                                     | Dimension (WXHXD)                             | mm                          | 960X320X205                        |
|                                     | Dimension of Carton Box (LXWXH)               | mm                          | 1040X400X318                       |
|                                     | Dimension of Package (LXWXH)                  | mm                          | 1043X403X333                       |
|                                     | Net Weight                                    | kg                          | 14                                 |
|                                     | Gross Weight                                  | kg                          | 17                                 |

|                                                    |                                                                 |                   |                                  |
|----------------------------------------------------|-----------------------------------------------------------------|-------------------|----------------------------------|
| Outdoor Unit                                       | Model                                                           |                   | ASH-18AIA PT                     |
|                                                    | Compressor Manufacturer/Trademark                               |                   | ZHUHAI LANDA COMPRESSOR CO.,LTD. |
|                                                    | Compressor Model                                                |                   | QXAT-B121zF070                   |
|                                                    | Compressor Oil                                                  |                   | 68EP                             |
|                                                    | Compressor Type                                                 |                   | Rotary                           |
|                                                    | L.R.A.                                                          | A                 | 40                               |
|                                                    | Compressor RLA                                                  | A                 | 6.6                              |
|                                                    | Compressor Power Input                                          | W                 | 1430                             |
|                                                    | Overload Protector                                              |                   | 1NT11L-6233                      |
|                                                    | Throttling Method                                               |                   | Electron expansion valve         |
|                                                    | Operation temp                                                  | °C                | 16~30                            |
|                                                    | Ambient temp (cooling)                                          | °C                | -18~54                           |
|                                                    | Ambient temp (heating)                                          | °C                | -30~24                           |
|                                                    | Condenser Form                                                  |                   | Aluminum Fin-copper Tube         |
|                                                    | Pipe Diameter                                                   | mm                | Φ7                               |
|                                                    | Rows-fin Gap                                                    | mm                | 2-1.4                            |
|                                                    | Coil Length (LXDXW)                                             | mm                | 852X38.1X660                     |
|                                                    | Fan Motor Speed                                                 | rpm               | 800                              |
|                                                    | Output of Fan Motor                                             | W                 | 60                               |
|                                                    | Fan Motor RLA                                                   | A                 | 0.5                              |
|                                                    | Fan Motor Capacitor                                             | μF                | /                                |
|                                                    | Air Flow Volume of Outdoor Unit                                 | m <sup>3</sup> /h | 3200                             |
|                                                    | Fan Type                                                        |                   | Axial-flow                       |
|                                                    | Fan Diameter                                                    | mm                | Φ520                             |
|                                                    | Defrosting Method                                               |                   | Automatic Defrosting             |
|                                                    | Climate Type                                                    |                   | T1                               |
|                                                    | Isolation                                                       |                   | I                                |
|                                                    | Moisture Protection                                             |                   | IP24                             |
|                                                    | Permissible Excessive Operating Pressure for the Discharge Side | MPa               | 4.3                              |
|                                                    | Permissible Excessive Operating Pressure for the Suction Side   | MPa               | 2.5                              |
|                                                    | Sound Pressure Level (H/M/L)                                    | dB (A)            | 56/-/-                           |
|                                                    | Sound Power Level (H/M/L)                                       | dB (A)            | 62/-/-                           |
| Dimension (WXHXD)                                  | mm                                                              | 965X700X396       |                                  |
| Dimension of Carton Box (LXWXH)                    | mm                                                              | 1026X455X735      |                                  |
| Dimension of Package (LXWXH)                       | mm                                                              | 1029X458X750      |                                  |
| Net Weight                                         | kg                                                              | 51                |                                  |
| Gross Weight                                       | kg                                                              | 55.5              |                                  |
| Refrigerant                                        |                                                                 | R410A             |                                  |
| Refrigerant Charge                                 | kg                                                              | 1.65              |                                  |
| Connection Pipe                                    | Length                                                          | m                 | 5                                |
|                                                    | Gas Additional Charge                                           | g/m               | 20                               |
|                                                    | Outer Diameter Liquid Pipe                                      | mm                | Φ6                               |
|                                                    | Outer Diameter Gas Pipe                                         | mm                | Φ12                              |
|                                                    | Max Distance Height                                             | m                 | 10                               |
|                                                    | Max Distance Length                                             | m                 | 25                               |
| Note: The connection pipe applies metric diameter. |                                                                 |                   |                                  |

The above data is subject to change without notice; please refer to the nameplate of the unit.

## 2.2 Operation Characteristic Curve

### ASH-13AIA PT

#### Cooling

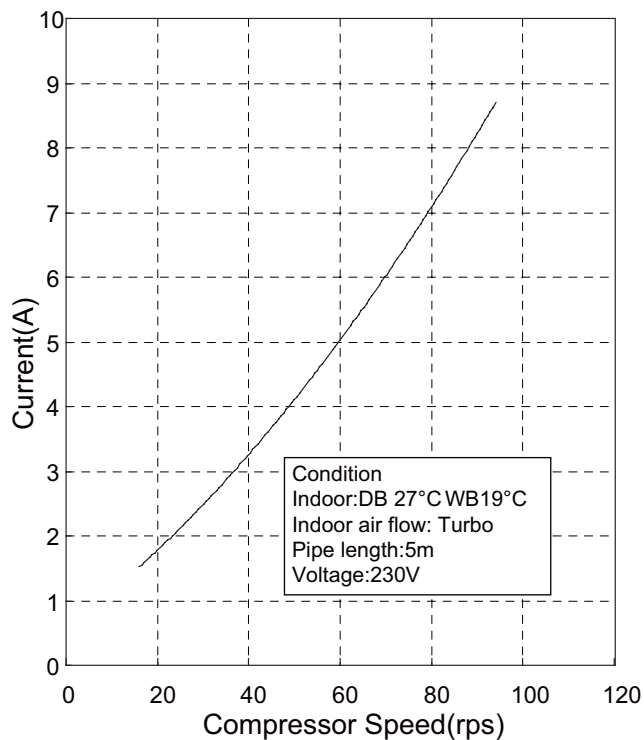

#### Heating

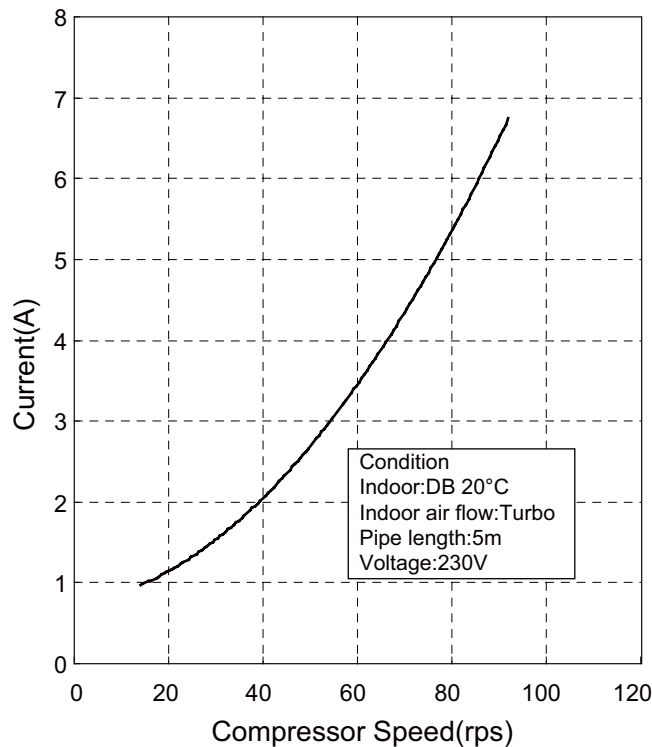

### ASH-18AIA PT

#### Cooling

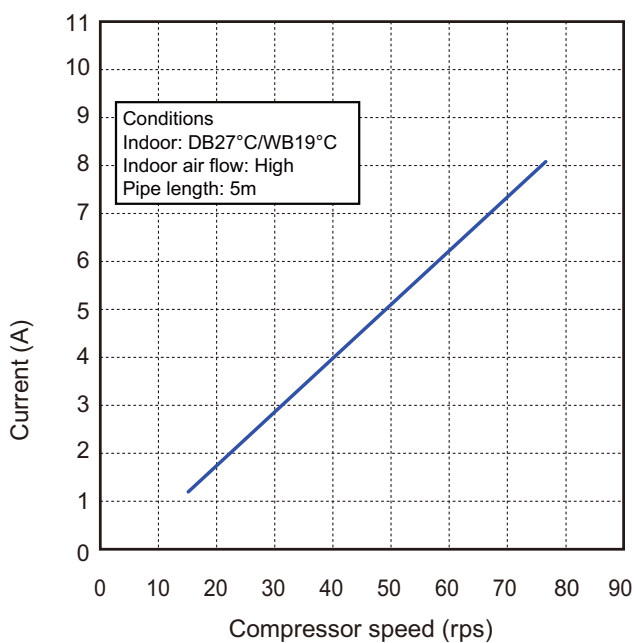

#### Heating

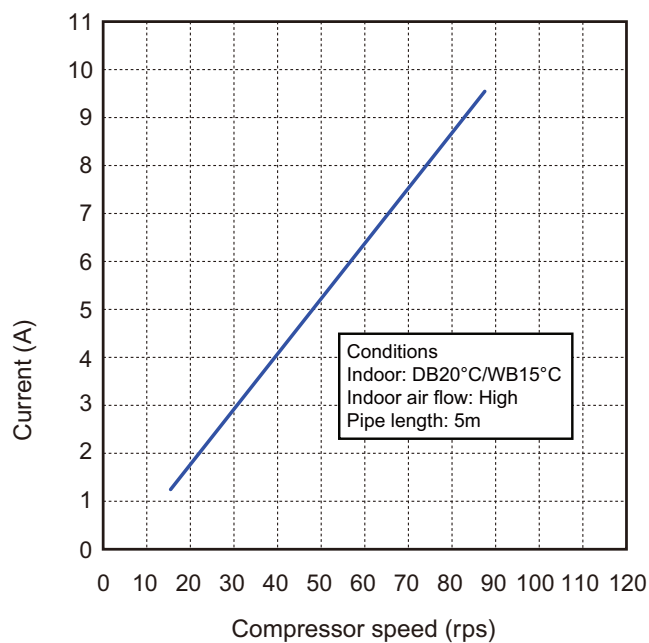

## 2.3 Capacity Variation Ratio According to Temperature

### ASH-13AIA PT

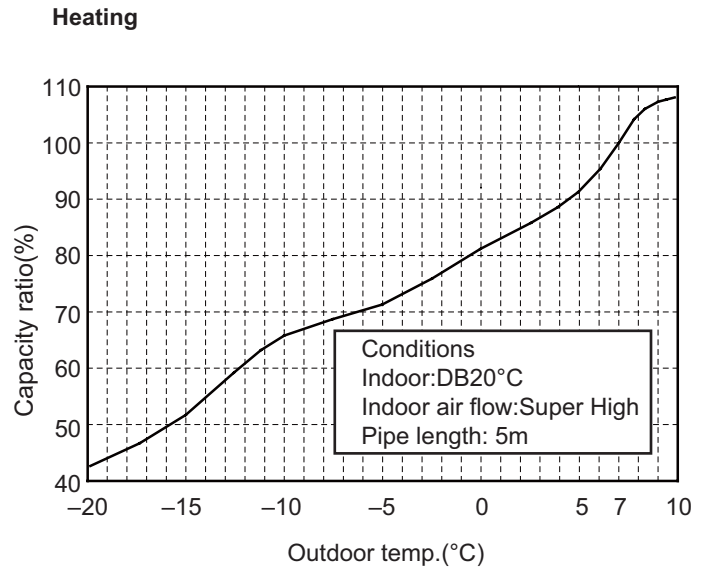
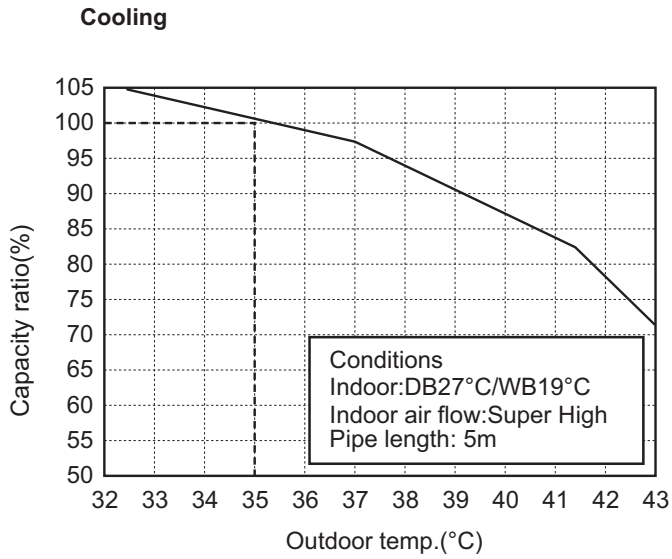

### ASH-18AIA PT

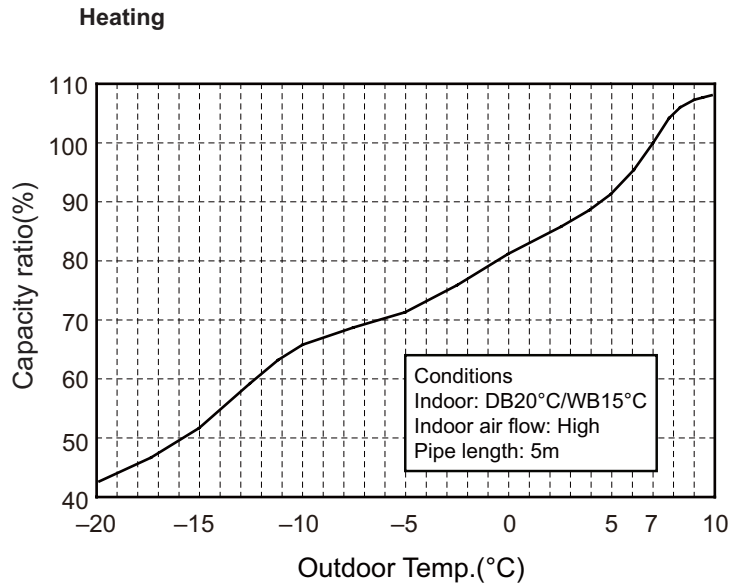
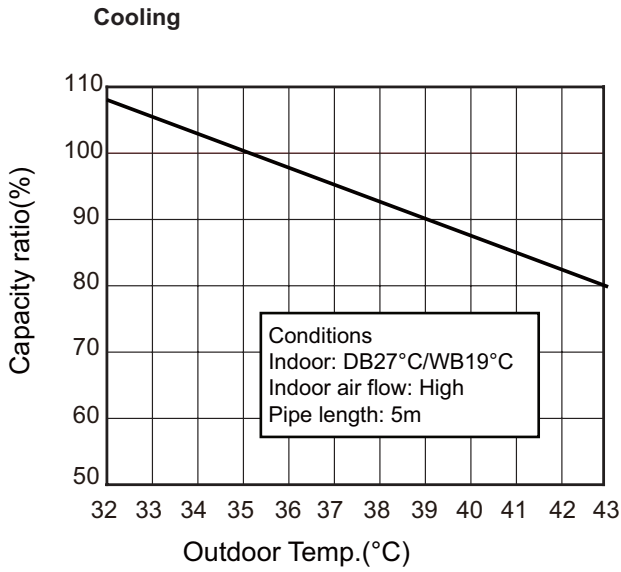

## 2.4 Cooling and Heating Data Sheet in Rated Frequency

Cooling:

| Rated cooling condition(°C) (DB/WB) |         | Model | Pressure of gas pipe connecting indoor and outdoor unit | Inlet and outlet pipe temperature of heat exchanger |                       | Fan speed of indoor unit | Fan speed of outdoor unit | Compressor revolution (Hz) |
|-------------------------------------|---------|-------|---------------------------------------------------------|-----------------------------------------------------|-----------------------|--------------------------|---------------------------|----------------------------|
| Indoor                              | Outdoor |       |                                                         | T1 (°C)                                             | T2 (°C)               |                          |                           |                            |
| 27/19                               | 35/24   | 13K   | 0.85~1.0                                                | in:8~11<br>out:11~14                                | in:50~80<br>out:37~43 | Turbo                    | Suprt High                | 58                         |
| 27/19                               | 35/24   | 18K   | 0.9~1.0                                                 | in:8~11<br>out:11~14                                | in:75~83<br>out:37~48 | Super High               | High                      | 73                         |

Heating:

| Rated heating condition(°C) (DB/WB) |         | Model | Pressure of gas pipe connecting indoor and outdoor unit | Inlet and outlet pipe temperature of heat exchanger |                   | Fan speed of indoor unit | Fan speed of outdoor unit | Compressor revolution (Hz) |
|-------------------------------------|---------|-------|---------------------------------------------------------|-----------------------------------------------------|-------------------|--------------------------|---------------------------|----------------------------|
| Indoor                              | Outdoor |       |                                                         | T1 (°C)                                             | T2 (°C)           |                          |                           |                            |
| 20/-                                | 7/6     | 13K   | 2.5~3.0                                                 | in:50~80<br>out:37~43                               | in:1~3<br>out:2~5 | Turbo                    | Suprt High                | 56                         |
| 20/15                               | 7/6     | 18K   | 2.2~2.4                                                 | in:75~83<br>out:37~45                               | in:1~3<br>out:2~6 | Super High               | High                      | 75                         |

**Instruction:**

T1: Inlet and outlet pipe temperature of evaporator

T2: Inlet and outlet pipe temperature of condenser

P: Pressure at the side of big valve

Connection pipe length: 5 m.

## 2.5 Noise Curve

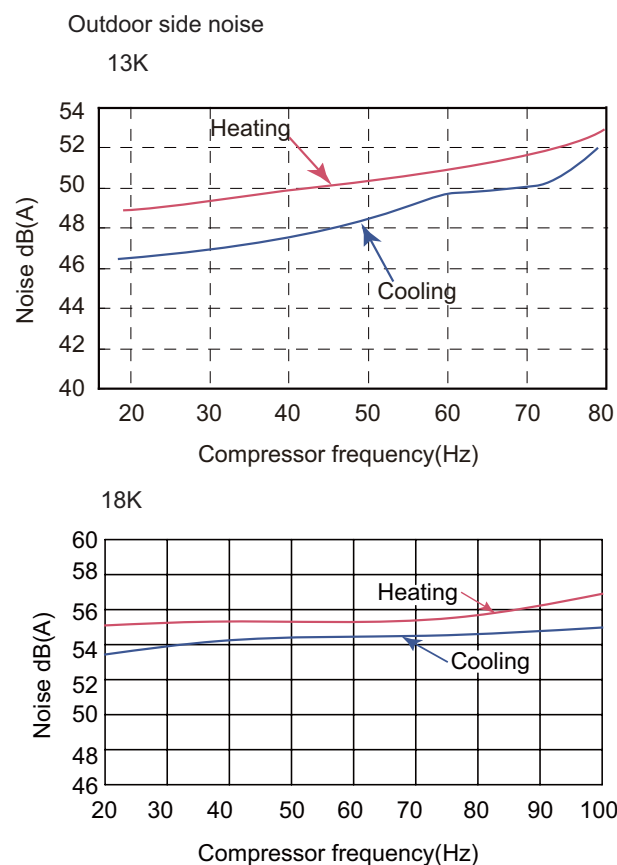
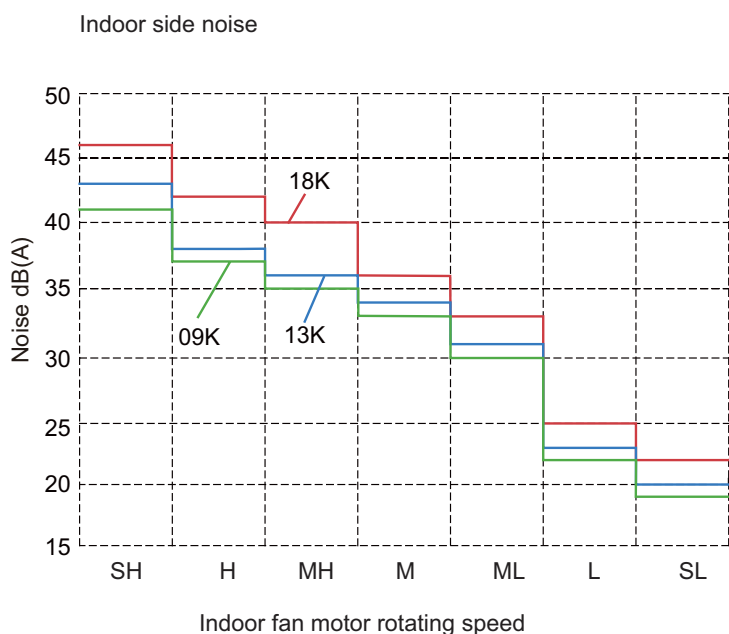

### 3. Outline Dimension Diagram

#### 3.1 Indoor Unit

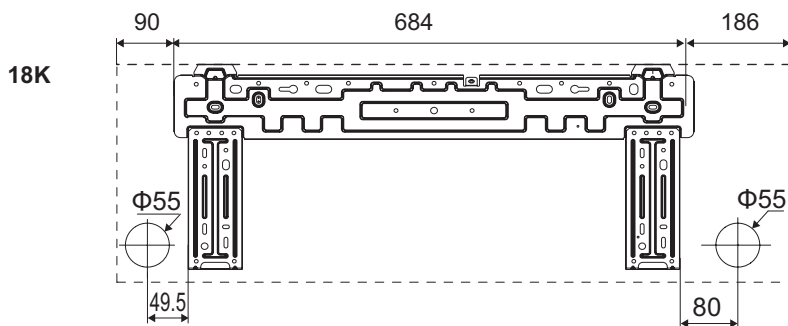
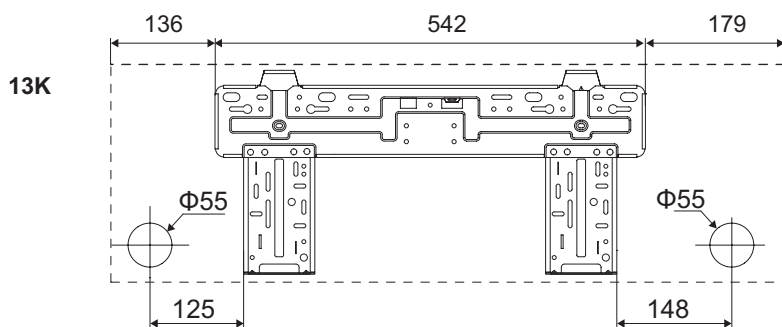
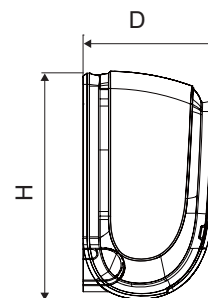
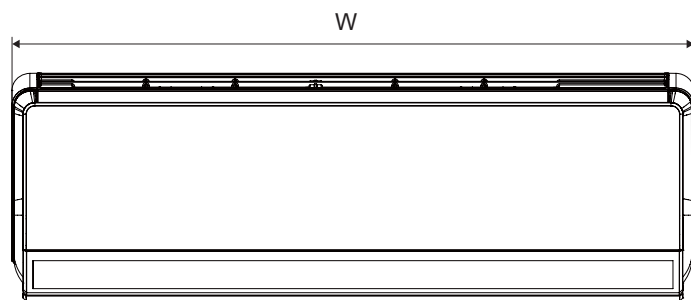

Unit:mm

| Model | W   | H   | D   |
|-------|-----|-----|-----|
| 13K   | 860 | 305 | 170 |
| 18K   | 960 | 320 | 205 |

### 3.2 Outdoor Unit

ASH-13AIA PT

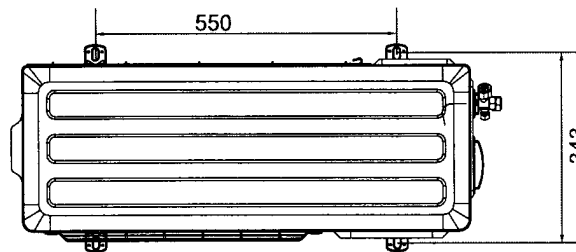
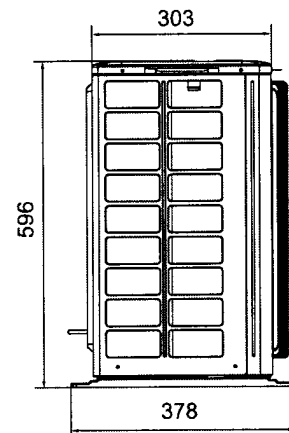
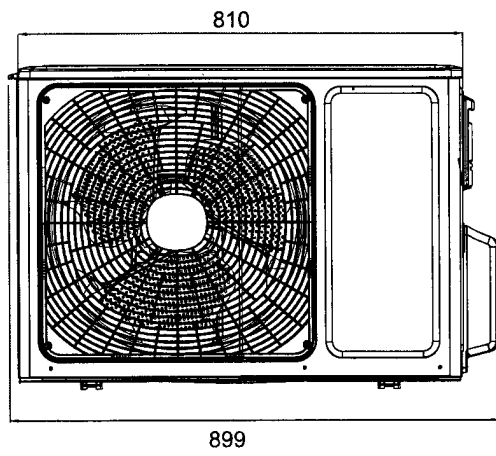

Unit:mm

ASH-18AIA PT

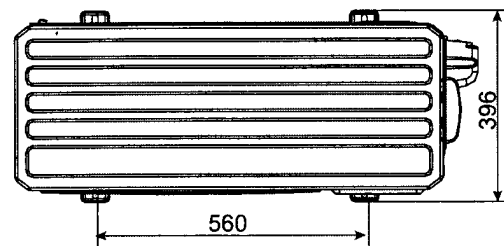
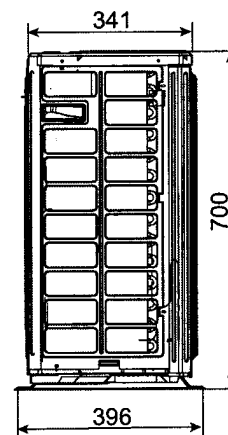
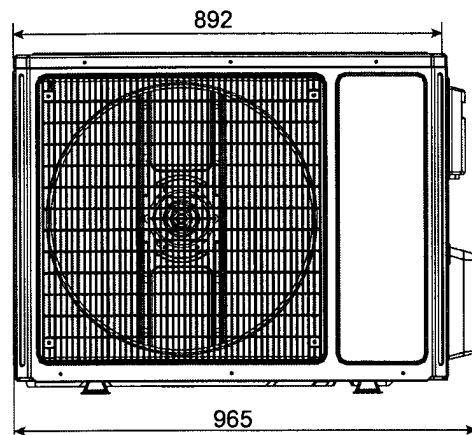

Unit:mm

## 4. Refrigerant System Diagram

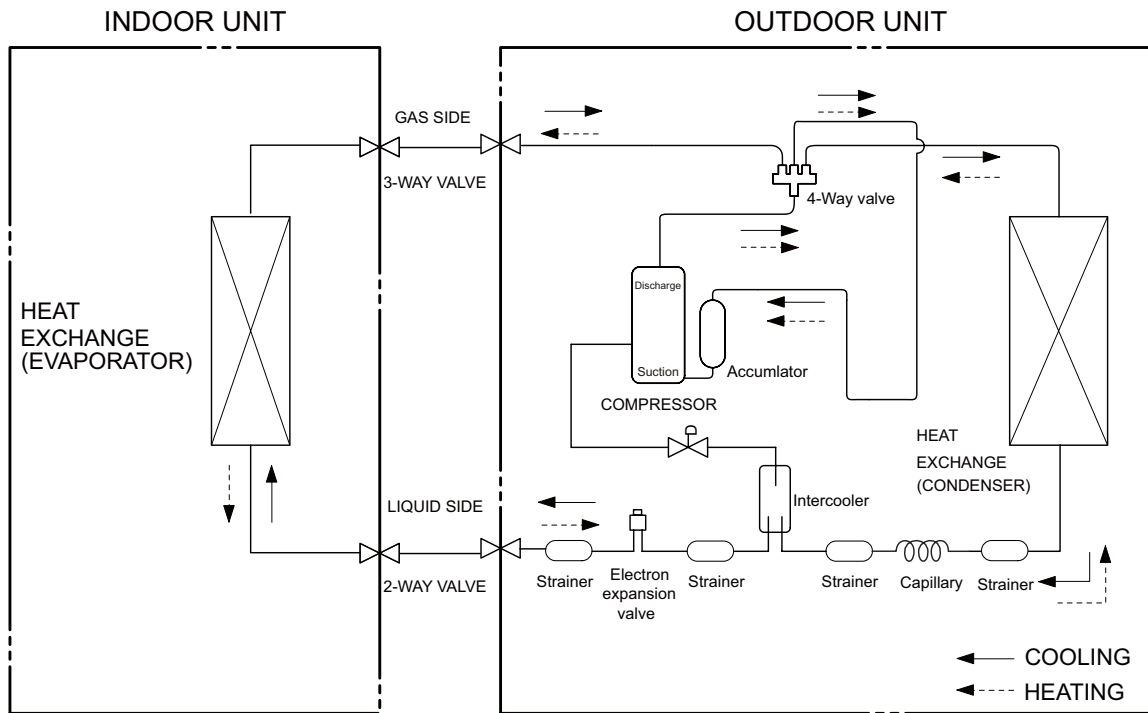

Connection pipe specification:  
Liquid : 1/4" (6mm) Gas : 1/2" (16mm)

## 5. Electrical Part

### 5.1 Wiring Diagram

● Instruction

| Symbol | Symbol Color | Symbol | Symbol Color | Symbol | Name           |
|--------|--------------|--------|--------------|--------|----------------|
| WH     | White        | GN     | Green        | CAP    | Jumper cap     |
| YE     | Yellow       | BN     | Brown        | COMP   | Compressor     |
| RD     | Red          | BU     | Blue         |        | Grounding wire |
| YEGN   | Yellow/Green | BK     | Black        | /      | /              |
| VT     | Violet       | OG     | Orange       | /      | /              |

Note: Jumper cap is used to determine fan speed and the swing angle of horizontal lover for this model.

● Indoor Unit

ASH-13AIA PT

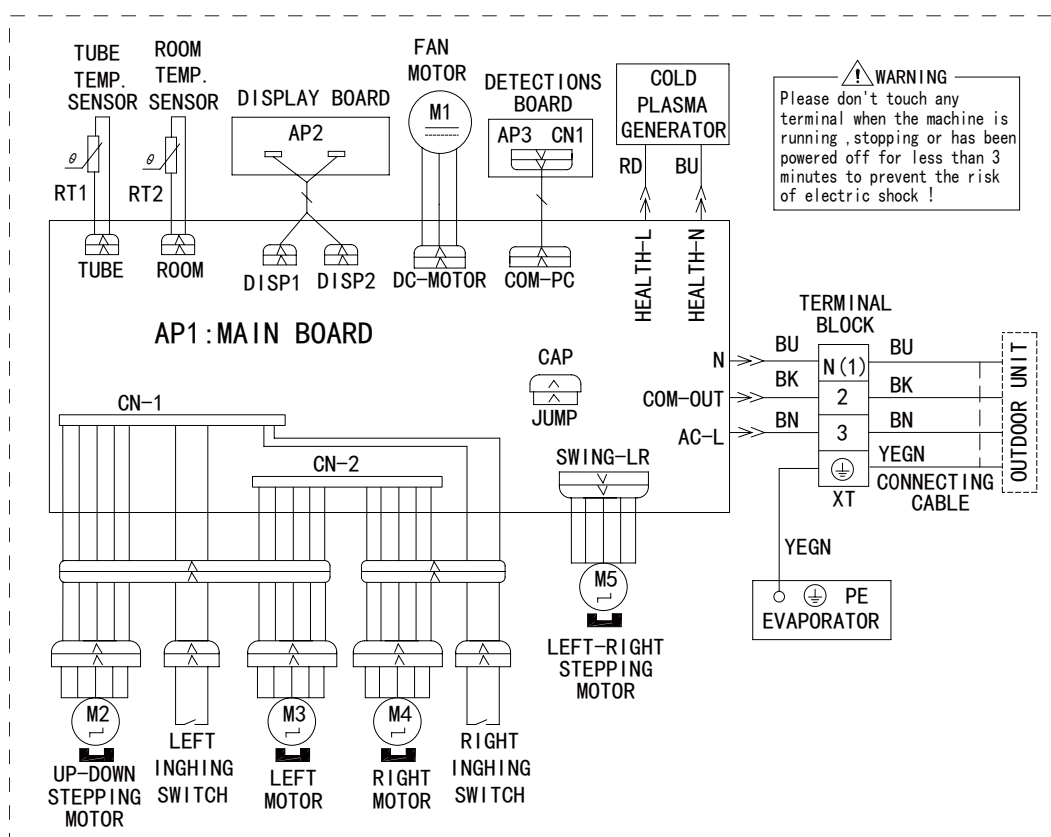



ASH-18AIA PT

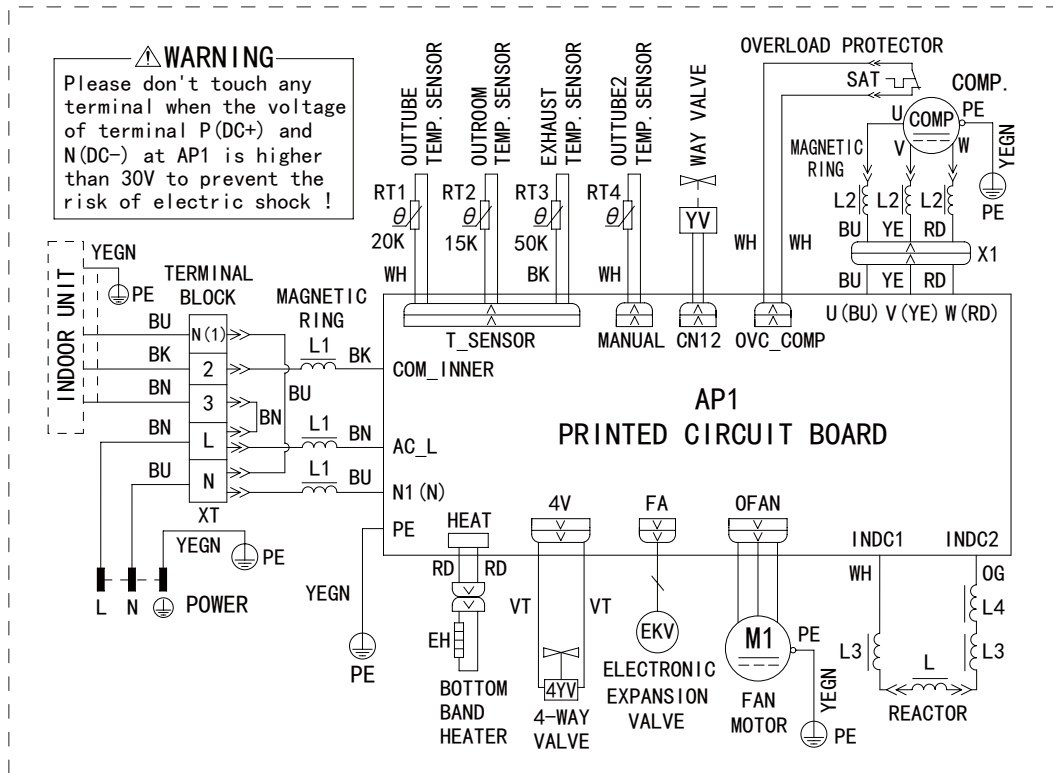

These wiring diagrams are subject to change without notice; please refer to the one supplied with the unit.

## 5.2 PCB Printed Diagram

### Indoor Unit

ASH-13AIA PT

#### • Top view

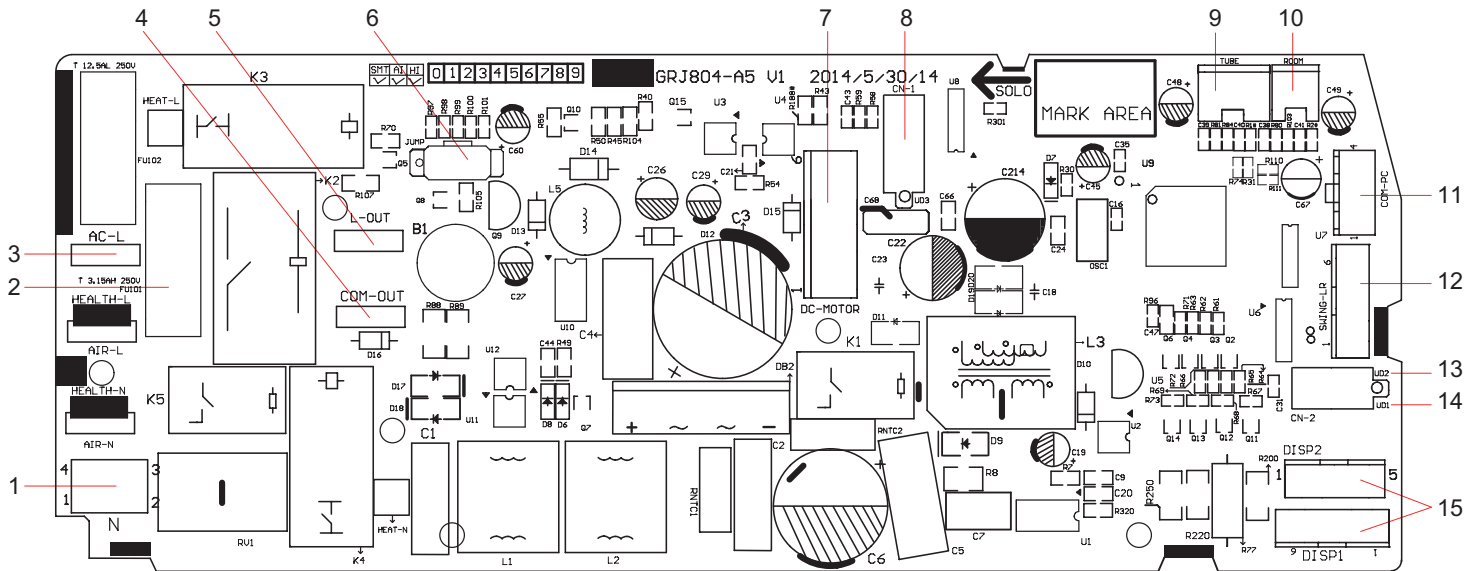

|   |                                                                |   |                                         |    |                                                   |    |                   |
|---|----------------------------------------------------------------|---|-----------------------------------------|----|---------------------------------------------------|----|-------------------|
| 1 | Interface of neutral wire                                      | 5 | Interface of live wire for outdoor unit | 9  | Tube temperature sensor                           | 13 | Up&down swing 2   |
| 2 | Interface of fuse                                              | 6 | Interface of jumper cap                 | 10 | Ambient temperature sensor                        | 14 | Up&down swing 1   |
| 3 | Interface of live wire                                         | 7 | Indoor fan motor                        | 11 | Communication interface for radio-frequency, WIFI | 15 | Display interface |
| 4 | Interface of communication wire for neutral wire and live wire | 8 | Up&down swing 3                         | 12 | Interface of left&right swing                     | /  | /                 |

#### • Bottom view

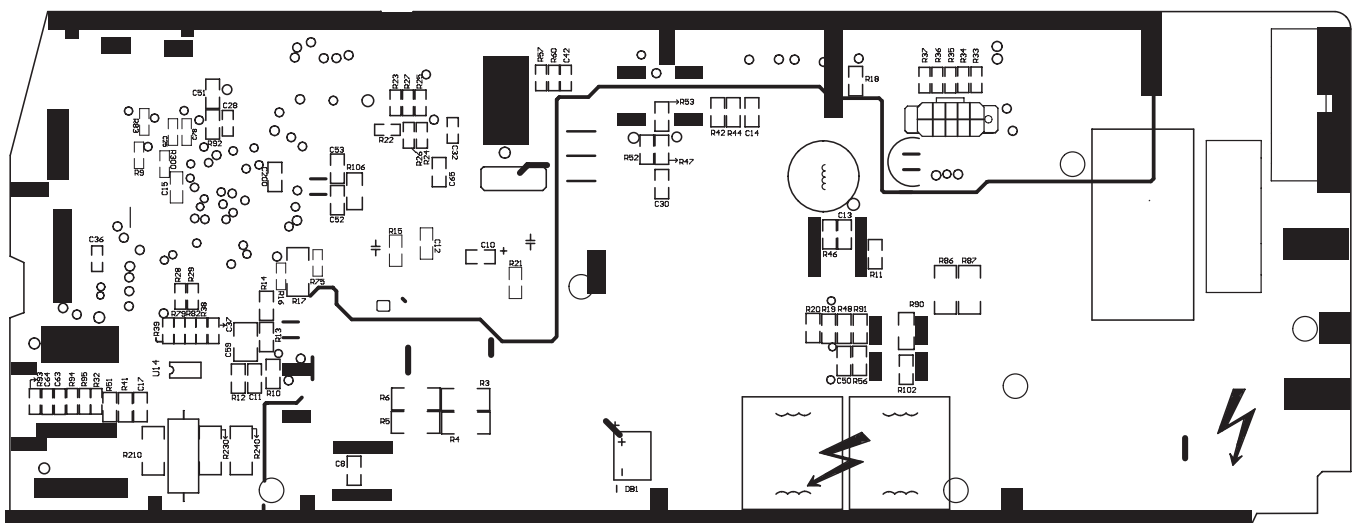

ASH-18AIA PT

• Top view

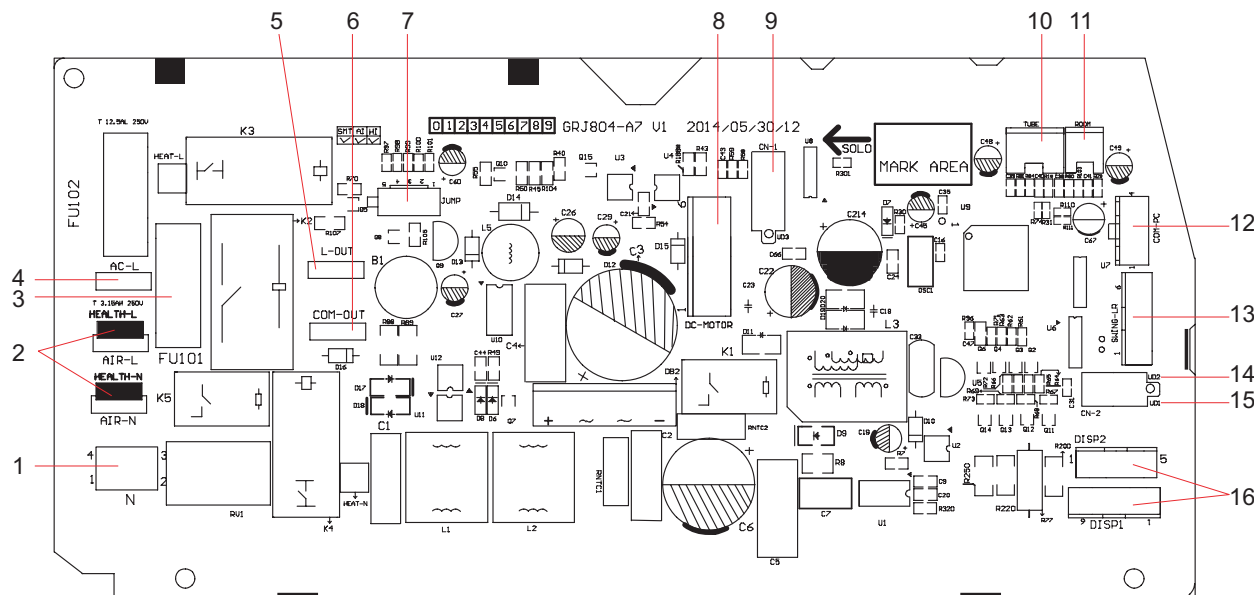

|   |                           |   |                                                                |    |                                                   |    |                               |
|---|---------------------------|---|----------------------------------------------------------------|----|---------------------------------------------------|----|-------------------------------|
| 1 | Interface of neutral wire | 5 | Interface of live wire for outdoor unit                        | 9  | Up&down swing 3                                   | 13 | Interface of left&right swing |
| 2 | Health interface          | 6 | Interface of communication wire for neutral wire and live wire | 10 | Tube temperature sensor                           | 14 | Up&down swing 2               |
| 3 | Interface of fuse         | 7 | Interface of jumper cap                                        | 11 | Ambient temperature sensor                        | 15 | Up&down swing 1               |
| 4 | Interface of live wire    | 8 | Interface of DC motor                                          | 12 | Communication interface for radio-frequency, WIFI | 16 | Display interface             |

• Bottom view

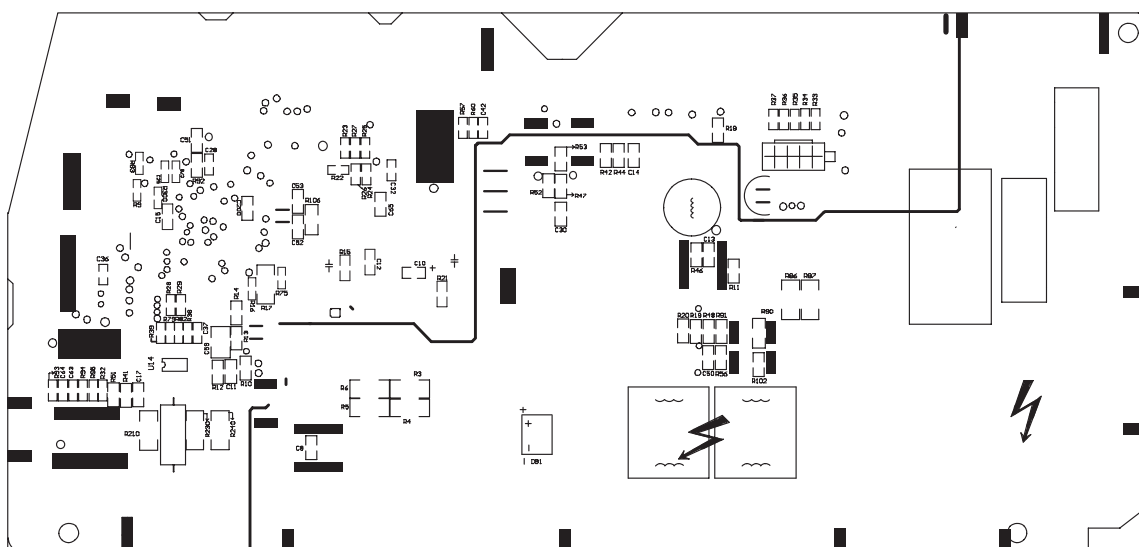

Outdoor Unit

ASH-13AIA PT

• Top view

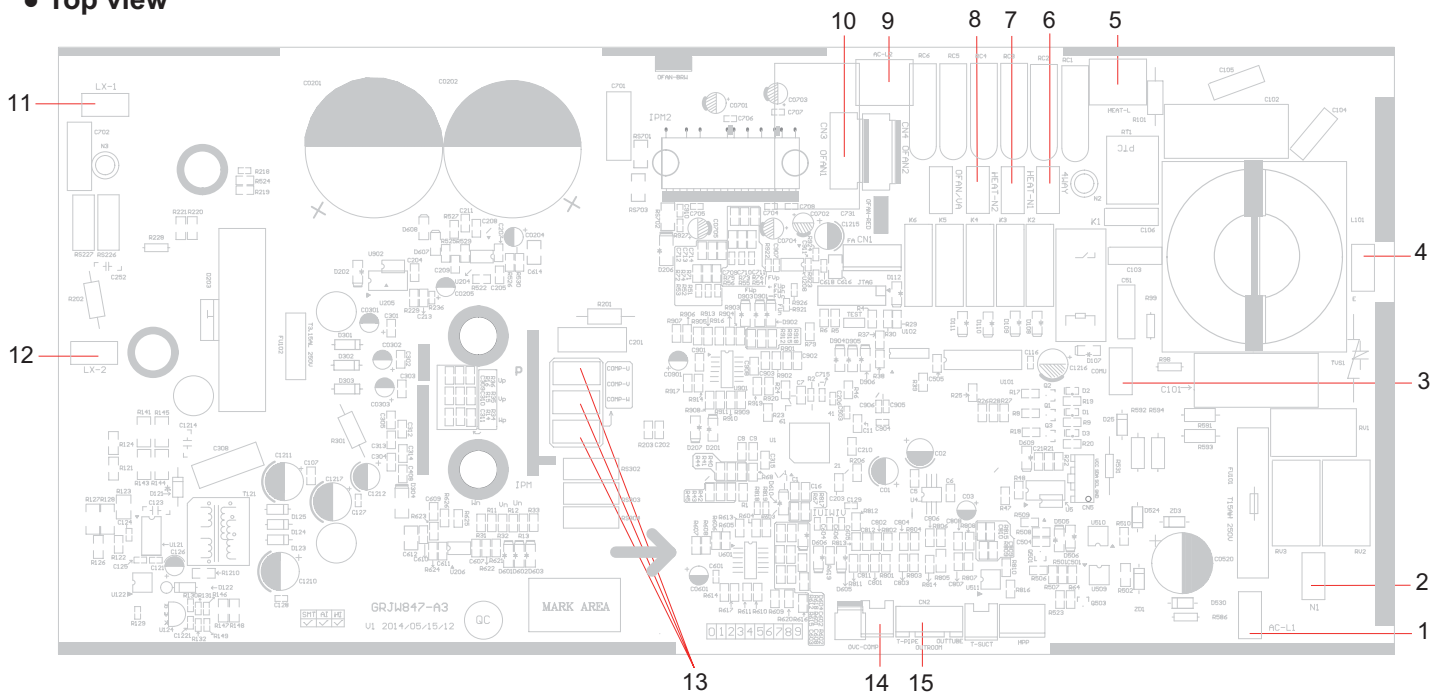

|   |                                |   |                               |   |                                               |    |                                 |    |                                  |
|---|--------------------------------|---|-------------------------------|---|-----------------------------------------------|----|---------------------------------|----|----------------------------------|
| 1 | Input of live wire of power    | 4 | Input of ground wire of power | 7 | Neutral wire of electric heater of compressor | 10 | Interface of fan                | 13 | U,V,W three phases of compressor |
| 2 | Input of neutral wire of power | 5 | Live wire of electric heater  | 8 | Neutral wire of electric heater of chassis    | 11 | Interface 1 of electric reactor | 14 | Input of overload                |
| 3 | Communication interface        | 6 | Neutral wire of 4-way valve   | 9 | Live wire of 4-way valve                      | 12 | Interface 2 of electric reactor | 15 | Temp. sensor                     |

• Bottom view

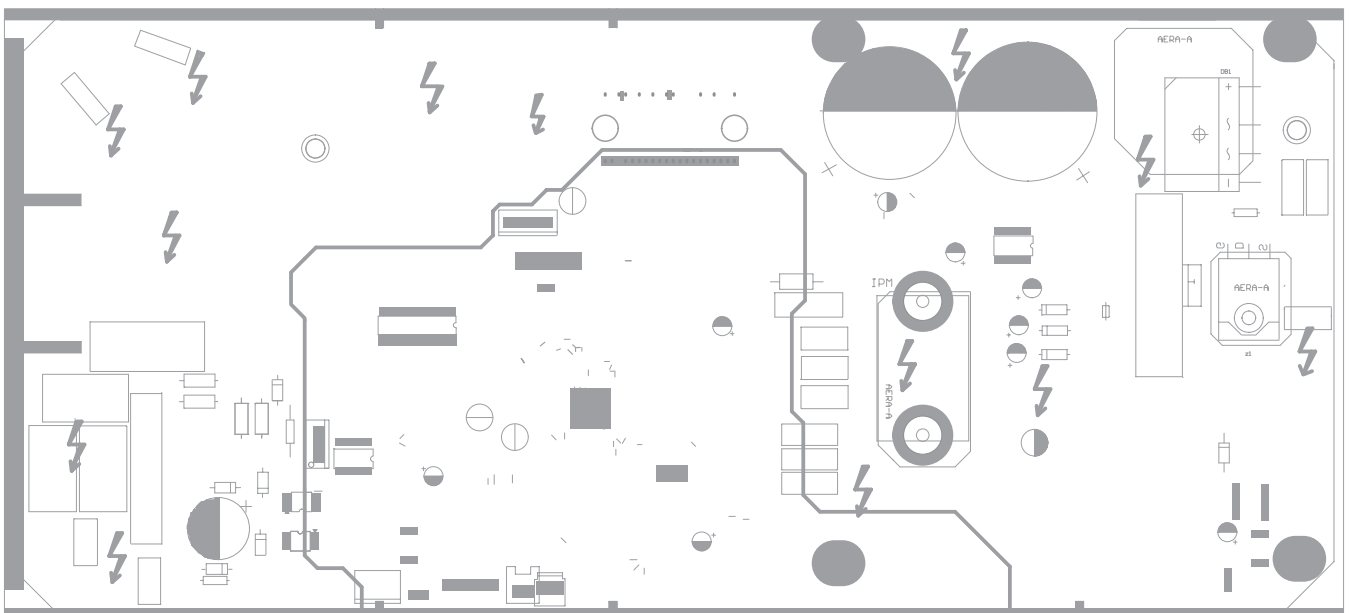

ASH-18AIA PT

• Top view

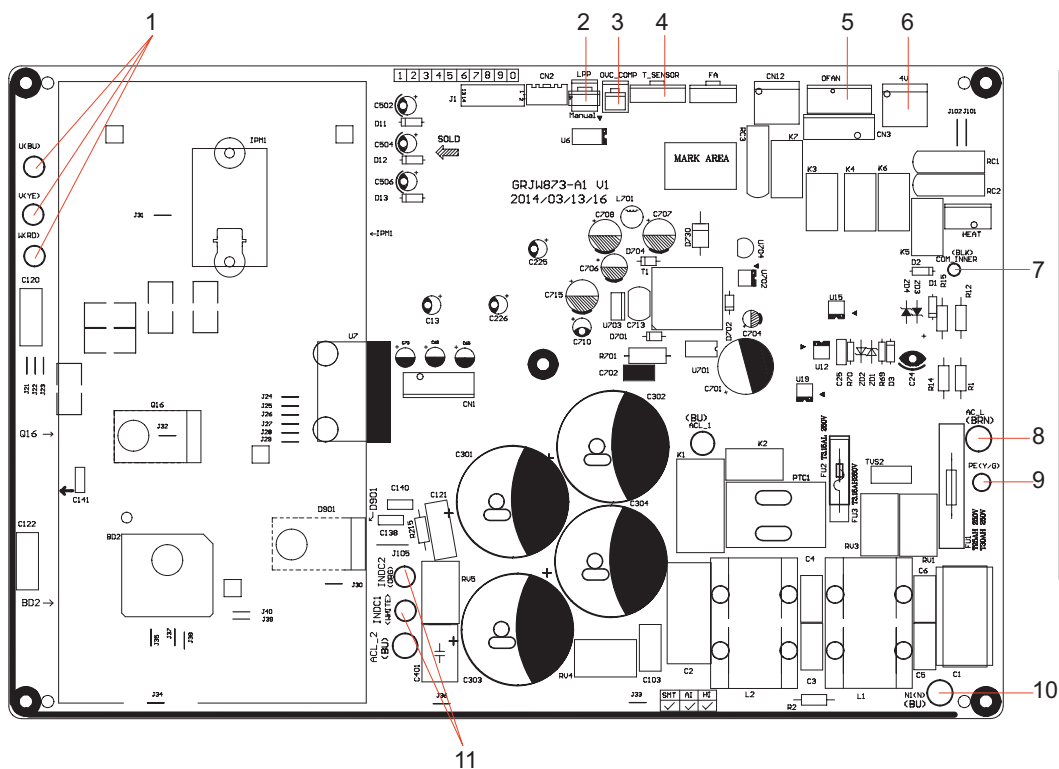

|    |                                            |
|----|--------------------------------------------|
| 1  | Terminal of compressor wire                |
| 2  | Terminal of low pressure protection        |
| 3  | Terminal of compressor overload protection |
| 4  | Terminal of outdoor temperature sensor     |
| 5  | Terminal of outdoor fan                    |
| 6  | Terminal of 4-way valve                    |
| 7  | Communication wire with indoor unit        |
| 8  | Power supply live wire                     |
| 9  | Earthing wire                              |
| 10 | Power supply neutral wire                  |
| 11 | PFC induction wire                         |

• Bottom view

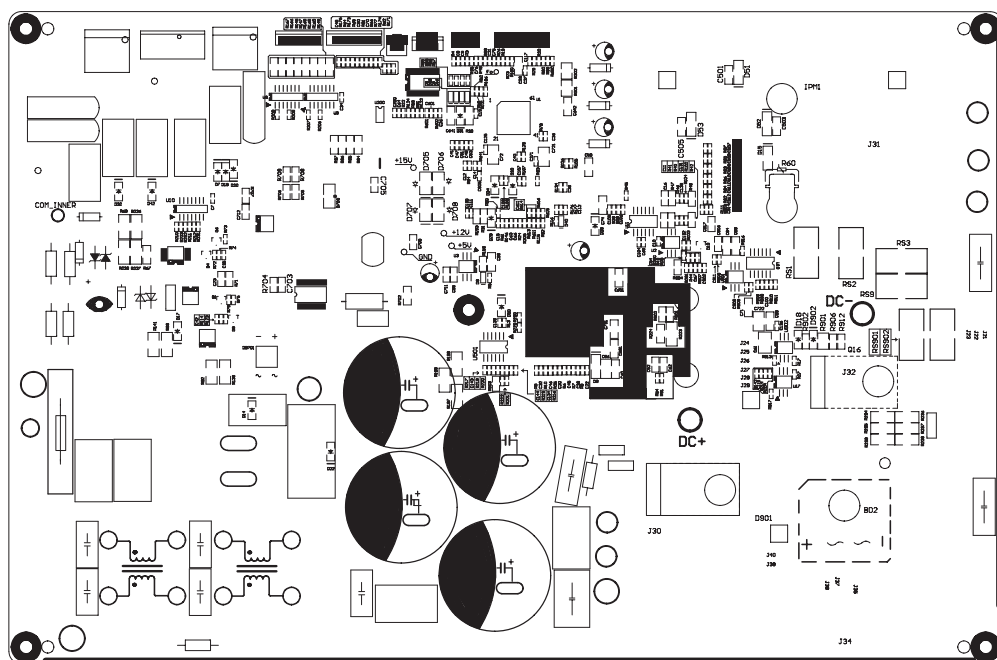

## 6. Function and Control

### 6.1 Remote Controller Introduction

#### Specialties note

##### Matching instructions



This model adopts RF remote control. The remote controller shall be matched with the air conditioner before operation, otherwise the remote control will be invalid. Before operation, please read the instructions in this page carefully and then do the corresponding matching operation.

#### Note:

- Please done the following operation within 6.56ft from the unit. Matching is not needed anymore once it is done.
- During matching, please keep the remote controller and air conditioner under standby status.
- When the signal of remote controller can't be received, please match the remote controller with the unit again.

#### Matching of remote controlle

When the unit is under standby status, please get close to the air conditioner within 6.56ft and then hold on pressing Humidity/Health button for 3s. The remote controller and air conditioner will enter matching automatically. If matching is done, the unit will give out three sounds; if matching is failed, please get closer to the unit and arrange matching again.

#### Buttons on Remote Controller

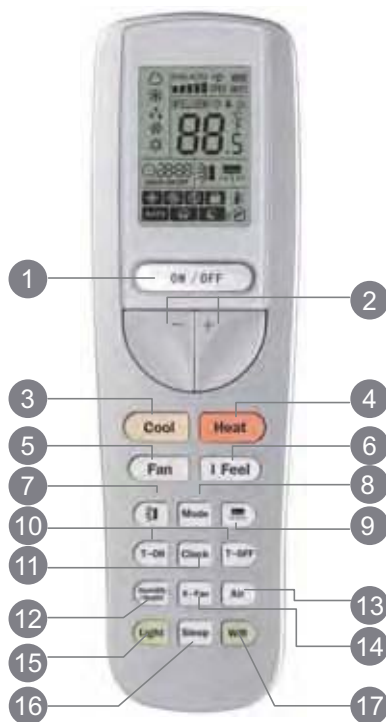

- ① ON/OFF button
- ② +/- button
- ③ Cool button
- ④ Heat button
- ⑤ Fan button
- ⑥ I FEEL button
- ⑦ up down swing button
- ⑧ Mode button
- ⑨ Left right swing button
- ⑩ T-ON/T-OFF button
- ⑪ Clock button
- ⑫ Humidity button/Health button
- ⑬ X-fan button
- ⑭ Air button
- ⑮ Light button
- ⑯ Sleep button
- ⑰ WIFI button

## Introduction for Icons on Display Screen

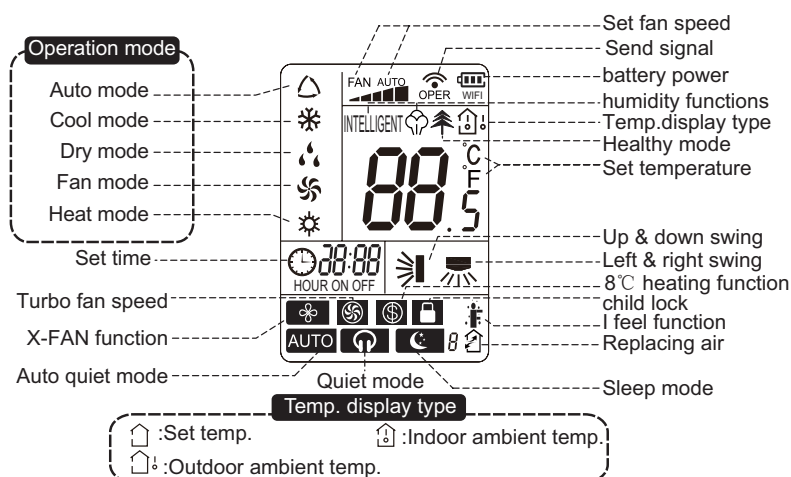

## Introduction for Buttons on Remote Controller

### Note:

- After putting through the power, the air conditioner will give out a sound. Operation indicator " ⏻ " is ON (red indicator). After that, you can operate the air conditioner by using remote controller.
- Under on status, pressing the button on the remote controller, the signal icon " 📶 " on the display of remote controller will blink once and the air conditioner will give out a "de" sound, which means the signal has been sent to the air conditioner.

### 1. ON/OFF Button

Press this button can turn on or turn off the air conditioner. After turning on the air conditioner, operation indicator " ⏻ " on indoor unit's display is ON (green indicator. The colour is different for different models), and indoor unit will give out a sound.

### 2. +/- button

Press "+" or "-" button once increase or decrease set temperature 0.5 °C. Holding "+" or "-" button, 2s later, set temperature on remote controller will change quickly. On releasing button after setting is finished, temperature indicator on indoor unit will change accordingly. (Temperature can't be adjusted under auto mode)

When setting TIMER , press "+" or "-" button to adjust time.

### 3. Cool button

Press this button, unit will operate in cool mode.

### 4. Heat button

Press this button, unit will operate in heat mode.

### 5. FAN button

Pressing this button can set fan speed circularly as: low( ▣ ), low medium( ▣▣ ), medium( ▣▣▣ ), medium high( ▣▣▣▣ ), high( ▣▣▣▣▣ ), super( 🌀 ), auto(AUTO), quiet( 🌀 ).



### Note:

- Turbo function is not available under dry and auto mode.
- Automatically operate silent speed when starting sleep function.
- The unit operates at low speed under dry and auto dry mode. The speed can't be adjusted.
- Under AUTO speed, air conditioner will select proper fan speed automatically according to ambient temperature.



### 6. I FEEL button

Press this button to start I FEEL function and " 🌡️ " will be displayed on the remote controller. After this function is set, the remote controller will send the detected ambient temperature to the controller and the unit will automatically adjust the indoor temperature according to the detected temperature. Press this button again to close I FEEL function and " 🌡️ " will disappear.

- Please put the remote controller near user when this function is set. Do not put the remote controller near the object of high temperature or low temperature in order to avoid detecting inaccurate ambient temperature.

**7.  button**

Under simple swing mode, press this button can turn on (display "" icon ) or turn off ( not display "" icon) left&right swing function.

Under OFF status, press "+" button and "" button simultaneously can switch between simple swing mode and fixed swing mode. During switching time, "" icon on remote controller will flash twice.

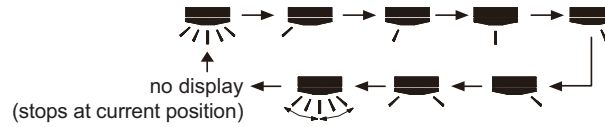

Under fixed-angle swing mode, press this button and the left and right swing status will change in the sequence as below:







**8. MODE button**

Press this button to select your required operation mode.





When selecting auto mode, air conditioner will operate automatically according to ambient temperature. Set temperature can't be adjusted and will not be displayed as well. Press "FAN" button can adjust fan speed. Press "" / "" button can adjust fan blowing angle.

After selecting cool mode, air conditioner will operate under cool mode. Press "+" or "-" button to adjust set temperature. Press "FAN" button to adjust fan speed. Press "" / "" button to adjust fan blowing angle.

When selecting dry mode, the air conditioner operates at low speed under dry mode. Under dry mode, fan speed can't be adjusted. Press "" / "" button to adjust fan blowing angle.

When selecting fan mode, the air conditioner will only blow fan, Press "FAN" button to adjust fan speed. Press "" / "" button to adjust fan blowing angle.

When selecting heating mode, the air conditioner operates under heat mode. Press "+" or "-" button to adjust set temperature. Press "FAN" button to adjust fan speed. Press "" / "" button to adjust fan blowing angle. (Cooling only unit won't receive heating mode signal. If setting heat mode with remote controller, press ON/OFF button can't start up the unit).

**Note:**

- For preventing cold air, after starting up heating mode, indoor unit will delay 1~5 minutes to blow air (actual delay time is depend on indoor ambient temperature).
- Set temperature range from remote controller: 16~30°C (61-86°F);

**9.  button**

Under simple swing mode, press this button can turn on ( display "" icon) or turn off ( not display "" icon) up&down swing function.

Under OFF status, press "+" button and "" button simultaneously can switch between simple swing mode and fixed swing mode.

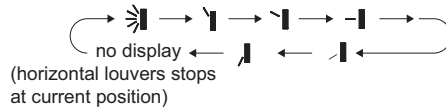

During switching time, "" icon on remote controller will flash twice.

Under fixed swing mode, press this button and up and down swing status will change in the sequence as below:





**10. T-ON/T-OFF button**

**T-ON button**

"T-ON" button can set the time for timer on. After pressing this button, "" icon disappears and the word "ON" on remote controller blinks. Press "+" or "-" button to adjust T-ON setting. After each pressing "+" or "-" button, T-ON setting will increase or decrease 1min. Hold "+" or "-" button, 2s later, the time will change quickly until reaching your required time. Press "T-ON" to confirm it. The word "ON" will stop blinking. "" icon resumes displaying. Cancel TIMER ON: Under the condition that T-ON is started up, press "T-ON" button to cancel it.

**T-OFF button**

"T-OFF" button can set the time for timer off. After pressing this button, "" icon disappears and the word "OFF" on remote controller blinks. Press "+" or "-" button to adjust T-OFF setting. After each pressing "+" or "-" button, T-OFF setting will increase or decrease 1min. Hold "+" or "-" button, 2s later, the time will change until reaching your required time. Press "T-OFF" to confirm it. The word "ON" will "OFF" will stop blinking. "" icon resumes displaying. Cancel T-OFF. Under the condition that T-OFF is started up, press "T-OFF" button to cancel it.

**Note:**

- Under on and off status, you can set T-OFF or T-ON simultaneously.
- Before setting T-ON or T-OFF, please adjust the clock time.
- After starting up T-ON or T-OFF, set the constant circulating valid. After that, air conditioner will be turned on or turned off according to setting time. ON/OFF button has no effect on setting. If you don't need this function, please use remote controller to cancel it.

**11. CLOCK button**

Press this button to set clock time. "🕒" icon on remote controller will blink. Press "+" or "-" button within 5s to set clock time. Each pressing of "+" or "-" button, clock time will increase or decrease 1 minute. Hold "+" or "-" button, 2s later, time will change quickly.

Release this button when reaching your required time. Press "CLOCK" button to confirm the time. "🕒" icon stops blinking.

**Note:**

- Clock time adopts 24-hour mode.
- The interval between two operations can't exceeds 5s. Otherwise, remote controller will quit setting status. Operation for TIMER ON/TIMER OFF is the same.

**12. Humidity/health button**

Press this button to select your required operation mode.



**Note:**there is no this function for this unit. If press this button,the main unit will click, but it also runs under original status.

**13. X-FAN button**

Pressing this button in COOL or DRY mode, the icon "🌀" is displayed and the indoor fan will continue operation for 2 minutes in order to dry the indoor unit even though you have turned off the unit. After energization, X-FAN OFF is defaulted. X-FAN is not available in AUTO, FAN or HEAT mode.

This function indicates that moisture on evaporator of indoor unit will be blown after the unit is stopped to avoid mould.

- Having set X-FAN function on: After turning off the unit by pressing ON/OFF button indoor fan will continue running for about 2 min. at low speed. In this period, press X-FAN button to stop indoor fan directly.
- Having set X-FAN function off: After turning off the unit by pressing ON/OFF button, the complete unit will be off directly.

**14. Air button**

Press this button to select your required operation mode.

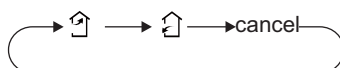

**Note:**there is no this function for this unit. If press this button,the main unit will click, but it also runs under original status.

**15. LIGHT button**

Pressing this button to turn off display light on indoor unit. Press this button again to turn on display light.

**16. SLEEP button**

Pressing this button can select Sleep 1, Sleep 2, Sleep 3, Sleep 4 or cancel Sleep circularly as below:

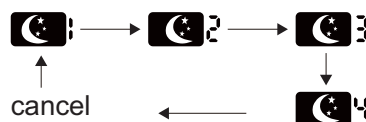

In Sleep 1 and Sleep 2, the air conditioner will run according to a group of presetting temperature curves.

- Sleep 3 - the sleep curve setting under DIY Sleep mode:

- (1) Under Sleep 3 mode, long press "AIR" button, the remote controller will enter the setting of personalized sleep. In this case, the timer zone of remote controller will display "1 hr" and the set temperature zone "88" will display the corresponding temperature of the last set sleep curve and blink (The first entering will display according to the initial curve setting value of manufacturer);
- (2) Press "+" and "-" button to adjust the corresponding temperature. After adjusting, press "AIR" button to confirm it;
- (3) At this time, the timer time on the remote controller will increase automatically by 1hr (that is "2 hr" or "3 hr" ... or "8 hr"). The set temperature zone "88" will display the corresponding temperature of the last set sleep curve and blink;
- (4) Repeat step(2) and step (3) until 8-hour temperature setting is finished, then the sleep curve is set successfully. After that, remote controller will resume displaying the original timer time and temperature zone will resume displaying the original set temperature.

- Sleep 3 - the sleep curve inquiry under DIY Sleep mode:

User can inquire the set sleep curve according to the setting method of sleep curve. Enter the setting of personalized sleep but do not change the temperature. Then press "AIR" button to confirm the setting.

**Note:** In the above setting or inquiry procedure, if there is no button pressing within 10s, remote controller will automatically exit the sleep curve setting and resume the original display. If ON/OFF, MODE, TIMER, HUMIDIFY, SLEEP, COOLING or HEATING button is pressed during the setting or inquiry procedure, remote controller will also exit the sleep curve setting.

- Sleep 4 is Siesta mode. The set temperature will change automatically according to the features of siesta.
- Sleep function will be disabled if the air condition is restarted after power failure; when sleep function is turned on, quite fan speed will be also turned on.
- Sleep function can not be set in AUTO mode.

#### 17. Wifi button

Press this button 3s can set wifi function on or OFF.

At OFF status, press mode button and wifi button, can reset wifi mode parameter and open wifi function.

#### About X-FAN function

This function indicates that moisture on evaporator of indoor unit will be blown after the unit is stopped to avoid mould.

1. Having set X-FAN function on: After turning off the unit by pressing ON/OFF button indoor fan will continue running for about 2 min. at low speed. In this period, press X-FAN button to stop indoor fan directly.
2. Having set X-FAN function off: After turning off the unit by pressing ON/OFF button, the complete unit will be off directly.

#### About AUTO RUN

When AUTO RUN mode is selected, the setting temperature will not be displayed on the LCD, the unit will be in accordance with the room temp. automatically to select the suitable running method and to make ambient comfortable.

#### About lock

Press + and - buttons simultaneously to lock or unlock the keyboard. If the remote controller is locked, the icon  will be displayed on it, in which case, press any button, the mark will flicker for three times. If the keyboard is unlocked, the mark will disappear.

#### About switch between Fahrenheit and Centigrade

Under status of unit off, press MODE and - buttons simultaneously to switch °C and °F.

### Operation guide

1. After putting through the power, press "ON/OFF" button on remote controller to turn on the air conditioner.
2. Press "MODE" button to select your required mode: AUTO, COOL, DRY, FAN, HEAT.
3. Press "+" or "-" button to set your required temperature. (Temperature can't be adjusted under auto mode).
4. Press "FAN" button to set your required fan speed: auto, low, medium and high speed.
5. Press "SWING" button to select fan blowing angle.

### Replacement of batteries in remote controller

1. Press the back side of remote controller marked with  as shown in the fig, and then push out the cover of battery box along the arrow direction.
2. Replace two 7# (AAA 1.5V) dry batteries, and make sure the position of "+" polar and "-" polar are correct.
3. Reinstall the cover of battery box.

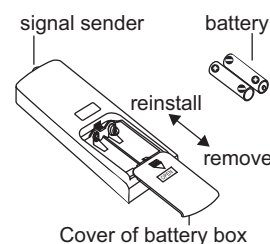

Battery level will be displayed on the remote controller. When  is flickering, please replace the batteries, otherwise, remote controller can't operate normally.

#### Note:

- During operation, point the remote control signal sender at the receiving window on indoor unit.
- The distance between signal sender and receiving window should be no more than 26.25ft, and there should be no obstacles between them.
- Signal may be interfered easily in the room where there is fluorescent lamp or wireless telephone; remote controller should be close to indoor unit during operation.
- Replace new batteries of the same model when replacement is required.
- When you don't use remote controller for a long time, please take out the batteries.
- If the display on remote controller is fuzzy or there's no display, please replace batteries.

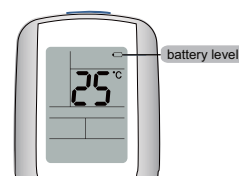

## 6.3 Brief Description of Modes and Functions

Conversion formula for Fahrenheit degree and Celsius degree:  $T_f = T_c \times 1.8 + 32$

### Indoor unit

#### 1. This controller includes functions as below

(1) Auto; (2) Cooling; (3) Dry; (4) Fan; (5) Heating

#### 2. Control object of controller

(1) Indoor unit :

Cooling mode: seven kinds of fan speed in total (including quiet, fan 1, fan 2, fan 3, fan 4, fan 5, turbo).

Heating mode: five kinds of fan speed in total (including quiet, fan 1, fan 2, fan 3, fan 4, fan 5, turbo).

Fan mode: Fan speed is same as that under cooling mode.

Dry mode: Low fan and quiet can be set under this mode. The fan speed is same as that for low fan under cooling mode.

Auto mode: Turbo is not available for this mode and the fan speed is same as that under each operation mode (cooling mode, fan mode, heating mode).

(2) Stepping motor for up&down swing.

(3) Stepping motor for swing mechanism.

(4) Stepping motor for left&right swing.

(5) E-heater.

(6) Health function (cold plasma reserved).

(7) Normal buzzer.

#### 3. Basic functions of system

##### (1) Cooling mode

① Operation condition and process for cooling mode ( refer to outdoor unit instruction for inverter unit).

② Protection function ( refer to outdoor unit instruction for inverter unit).

##### (2) Dry mode

① Operation condition and process for dry mode.

② Protection function ( refer to outdoor unit instruction for inverter unit).

##### (3) Heating mode (not for cooling only unit)

① Operation condition and process for heating mode.

② Defrosting condition and process (refer to outdoor unit instruction for inverter unit): As for normal intelligent defrosting; the unit will defrost automatically according to frosting condition and operation indicator will be on 10s and off 0.5s circularly. As for non-stop defrosting, the indoor fan will be started up according to the frosting condition and the operation indicator will be on 10s and off 0.5s circularly.

③ Protection function (refer to outdoor unit instruction for inverter unit).

##### (4) Fan mode

Under this mode, indoor fan operates at set fan speed. Compressor, outdoor fan, 4-way valve and electric heating tube all stop operation. Under this mode, the temperature setting range is 16~30°C . Operation icon and set temperature is displayed.

##### (5) Auto mode

Under auto mode, the system, the system will select the operation mode (cooling, heating, fan) according to the change of ambient temperature. Operation icon, actual operation mode icon and set temperature will be displayed. There's 30s time delay for protection for mode switchover. Protection function is same as that under each mode.

#### 4. Display status of indoor indicator

##### (1) Display status of indoor unit

① After energization, all display icons will be displayed and then only the power indicator is on. When turning on the unit with remote controller, the operation indicator is on and the current set operation mode will be displayed.

② During defrosting, the operation indicator will be on 10s and off 0.5s circularly. Under auto mode, the dual-8 nixie tube displays 25 under cooling mode or fan mode, and 20 under heating mode. Mode indicator is displayed according to the mode.

③ Dual-8 nixie tube displays set temperature.

##### (2) Error indicator display on indoor unit

| Display table for error status                                                     |                                                   |                     |
|------------------------------------------------------------------------------------|---------------------------------------------------|---------------------|
| Error name                                                                         | Error definition                                  | Dual-8 code display |
| Freon recovery mode                                                                | Operation status is displayed immediately         | Fo                  |
| Malfunction of indoor fan                                                          | Malfunction of hardware                           | H6                  |
| Malfunction of middle temperature sensor of indoor evaporator                      | Malfunction of hardware                           | F2                  |
| Malfunction of indoor ambient temperature sensor                                   | Malfunction of hardware                           | F1                  |
| Communication malfunction between indoor unit and outdoor unit                     | Malfunction of hardware                           | E6                  |
| Malfunction of jumper cap                                                          | Malfunction of hardware                           | C5                  |
| Limit/decrease frequency due to module current protection                          | Display through adjustment with remote controller | En                  |
| Limit/decrease frequency due to module temperature protection                      | Display through adjustment with remote controller | EU                  |
| Limit/decrease frequency due to overload protection                                | Display through adjustment with remote controller | F6                  |
| Limit/decrease frequency due to freeze prevention protection                       | Display through adjustment with remote controller | FH                  |
| Limit/decrease frequency due to discharge protection                               | Display through adjustment with remote controller | F9                  |
| Limit/decrease frequency due to AC current protection of outdoor unit              | Display through adjustment with remote controller | F8                  |
| Malfunction overload temperature sensor                                            | Malfunction of hardware                           | FE                  |
| Malfunction of outdoor discharge temperature                                       | Malfunction of hardware                           | F5                  |
| Malfunction of outdoor ambient temperature sensor                                  | Malfunction of hardware                           | F3                  |
| Malfunction of outdoor condenser temperature sensor                                | Malfunction of hardware                           | F4                  |
| Circuit malfunction of module temperature sensor                                   | Malfunction of hardware                           | P7                  |
| Overload protection of compressor                                                  | Other malfunction                                 | H3                  |
| Discharge protection                                                               | Other malfunction                                 | E4                  |
| Overload protection                                                                | Other malfunction                                 | E8                  |
| AC current protection of outdoor unit                                              | Other malfunction                                 | E5                  |
| Module current protection                                                          | Other malfunction                                 | H5                  |
| Module temperature protection                                                      | Other malfunction                                 | P8                  |
| Freeze prevention protection                                                       | Other malfunction                                 | E2                  |
| High power protection                                                              | Other malfunction                                 | L9                  |
| Lacking/inverse phase protection of compressor                                     | Other malfunction                                 | U2                  |
| PFC current malfunction                                                            | Other malfunction                                 | HC                  |
| High DC bus bar voltage protection                                                 | Other malfunction                                 | PH                  |
| Low DC bus bar voltage protection                                                  | Other malfunction                                 | PL                  |
| Freon-lacking protection                                                           | Other malfunction                                 | F0                  |
| Mode shock                                                                         | Malfunction of hardware                           | E7                  |
| Non-matching between indoor unit and outdoor unit                                  | Malfunction of hardware                           | LP                  |
| Read-write malfunction of memory chip                                              | Malfunction of hardware                           | EE                  |
| Abnormal changeover for 4-way valve                                                | Malfunction of hardware                           | U7                  |
| Malfunction of outdoor fan 2                                                       | Malfunction of hardware                           | LA                  |
| Malfunction of outdoor fan 1                                                       | Malfunction of hardware                           | L3                  |
| Low pressure protection                                                            | Other malfunction                                 | E3                  |
| High pressure protection                                                           | Other malfunction                                 | E1                  |
| Drop malfunction of DC bus bar voltage                                             | Other malfunction                                 | U3                  |
| Current detection malfunction for the complete unit                                | Malfunction of hardware                           | U5                  |
| Charging malfunction for capacity                                                  | Malfunction of hardware                           | PU                  |
| Phase current detection malfunction of compressor                                  | Malfunction of hardware                           | U1                  |
| Desynchronizing of compressor                                                      | Other malfunction                                 | H7                  |
| Demagnetizing protection of compressor                                             | Other malfunction                                 | HE                  |
| Failure startup of compressor                                                      | Other malfunction                                 | Lc                  |
| High peak current of compressor                                                    | Other malfunction                                 | P5                  |
| Conglutination malfunction of relay of refrigerant electric heater of outdoor unit | Malfunction of hardware                           | A2                  |
| Refrigerator heater of outdoor unit is invalid                                     | Display through adjustment with remote controller | A3                  |
| Malfunction of temperature sensor of refrigerant heater                            | Malfunction of hardware                           | A4                  |
| Malfunction exit tube temperature sensor for condenser                             | Malfunction of hardware                           | A5                  |
| Oil return                                                                         | Display through adjustment with remote controller | F7                  |
| Normal cooling and heating (capacity test code)                                    | Operation status is displayed immediately         | P1                  |
| Maximum cooling and heating (capacity test code)                                   | Operation status is displayed immediately         | P2                  |
| Medium cooling and heating (capacity test code)                                    | Operation status is displayed immediately         | P3                  |
| Minimum cooling and heating (capacity test code)                                   | Operation status is displayed immediately         | P0                  |

## 5. Other control

### (1) Timer function

Timer ON: Timer ON can be set under off status. After time is over, the unit will operate at original setting mode. The timer interval is 0.5h and the timer setting range is 05~24h.

Timer OFF: Timer OFF can be set under on status. After time is over, the unit will be turn off. The timer interval is 0.5h and the timer setting range is 05~24h.

### (2) Auto button

Press this button and the unit will operate at auto mode. Indoor fan operates at auto fan speed and the swing motor operates. Press this button again to turn off the unit.

### (3) Buzzer

Upon energization or availably operating the unit or remote controller, the buzzer will give out a beep.

### (4) Sleep function

In SLEEP mode, the unit will automatically select appropriate sleep curve to operate according to different temperature setting.

### (5) Turbo Function

This function can be set in cooling or heating mode.

### (6) X-fan function

X-fan function can be set in cooling or drying mode.

### (7) Compulsory defrosting function

#### ① turn on compulsory defrosting function

Under on status, set heating mode with remote controller and adjust the temperature at 16°C . When pressing “+, -, +, -, +, -” button successively within 5s and the complete unit will enter into compulsory defrosting status. Meanwhile, operation indicator on indoor unit is on 10s and off 0.5s circularly. (Note: If the complete has malfunction or stops operation due to protection, compulsory defrosting function can be started up only after malfunction or protection is resumed.)

#### ② Exit compulsory defrosting mode

After compulsory defrosting is started up, the complete unit will exit defrosting according to actual defrosting result automatically. The complete unit will resume heating operation normally.

### (8) Refrigerant recovery function (applicable for movement or maintenance)

#### ① Start up refrigerant recovery function

Within 5min after energization (on or off status), set cooling mode with remote controller and adjust the temperature at 16°C . When pressing light button on remote controller to any one indoor unit for 3 times within 3s, the complete unit will enter into refrigerant recovery status after setting is succeeded and all indoor unit displayed F0. After that, maintenance staff turns off all liquid valves. 5min later, hold all thimbles at service valves in turn with tools. If there's no refrigerant spurting out, turn off corresponding gas valve immediately, turn off the unit with remote controller and then you can disassemble the connection pipe.

#### ② Quit refrigerant recovery function

During refrigerant recovery process, if any one indoor unit receives any remote control signal or refrigerant recovery function has operated for 25min, the unit will exit refrigerant recovery function. If the complete unit is at standby status before refrigerant recovery, the unit is still at standby status after refrigerant recovery. If the complete unit is at operation status before refrigerant recovery, the unit will operate at original operation mode after refrigerant recovery.

#### ③ After entering refrigeratn recovery function

Indoor unit operates at cooling mode. Fan speed is super high fan speed and the set temperature is 16°C. The horizontal louver will stay at the minimum operation angle.

### (9) Auto fan speed control

Under this mode, indoor fan will select high, high-medium, medium, medium-low or low fan speed according to ambient temperature sensor.

### (10) Left&right swing control

Select different left&right swing direction according to remote control status of left&right swing.

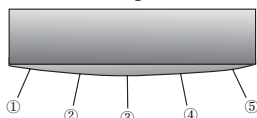

### (11) Up&down swing control

Up&down swing is composed of swing mechanism and swing blade;

After energization, the swing mechanism will perform reset action. The horizontal louver will open to the maximum angle and then be closed;

After turning on the unit, the swing mechanism will extend different length according to remote control status. By view of the position

of swing blade, there are upper swing and lower swing.

When selecting fixed-angle swing, you can select 5 kinds of swing position for blowing fan;

After selecting free swing, lower swing for heating mode and upper swing for cooling mode.

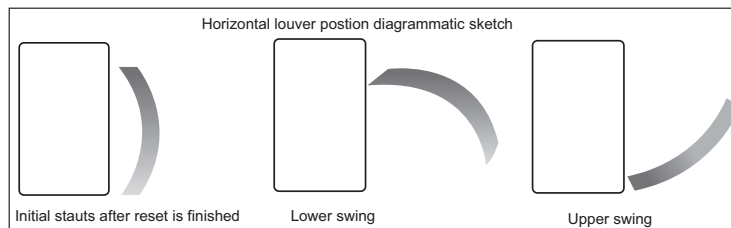

## (12) Display

### ① Display of operation icon and mode icon

After energization, all icon will be displayed for once. Under standby status, operation icon will be in white. After turning on the unit with remote controller, the icon for the current operation mode will be displayed (mode: cooling, heating, 0.5, defrosting, frequency visual). After pressing light button to turn off light, all displays will be turned off. When turning on the unit, the backlight indicator will be turned on; when turning off the unit or light button, backlight indicator won't be turned on.

### ② Dual-8 nixie tube display

When turning on the unit after energization for the first time, the nixie tube is defaulted to display current set temperature (the temperature setting range is 16~30°C). When it received the signal of display set temperature, the nixie tube displays set temperature; when it received the signal of display ambient temperature, the nixie tube will display current indoor ambient temperature; if remote control to set other status, the display won't change. F1 will be displayed for the malfunction of ambient temperature sensor; F2 will be displayed for the malfunction of indoor tube temperature sensor; C5 will be displayed for the malfunction of jumper cap.

## (13) Locked protection to motor

After turning on the fan, when the motor operates at low speed for a period of time, it will stop operation for preventing auto protection of motor and lockage will be displayed. If it's at on status, dual-8 nixie tube displays lockage error code H6; if it's at off status, lockage information won't be displayed.

## 6. Special Functions

### (1) Rf control function

There are three optional mode—air, humidify and air purifier. After matching is succeeded, you can control the related mode through remote controller.

### (2) I Feel function

When I FEEL command is received, the controller will operate according to the ambient temperature sent by the remote controller (For defrosting and cold blow prevention, the unit operates according to the ambient temperature sensed by the air conditioner). The remote controller will regularly send ambient temperature data to the controller. When the data has not been received for a long time, the unit will operate according to the temperature sensed by the air conditioner. If I FEEL function is not selected, the ambient temperature will be that sensed by the air conditioner. I FEEL function is not to be memorized.

### (3) Malfunction detecting of temperature sensor

When it detected that there's malfunction of indoor ambient temperature sensor, it will display F1; when it detected that there's malfunction of indoor tube temperature sensor, it will display F2.

### (4) Low power consumption standby function

When the air conditioner is in power off and at standby status, it will enter into low power consumption standby status 6 minutes later, and the operation indicator will be turned off.

## 7. Error Analysis

### (1) Error 1: No response after energization, and buzzer does not give out a beep.

Solution: Please check the power supply or replace the controller.

### (2) Error 2: Dual-8 nixie tube of display board displays "C5".

Solution: The jumper cap has not been firmly connected to the controller, please reinsert or replace the jumper cap with the same specification.

### (3) Error 3: Dual-8 nixie tube of display board displays "F1".

Solution: The ambient temperature sensor of air conditioner has not been firmly connected to the controller, please reinsert or replace an ambient temperature sensor.

### (4) Error 4: Dual-8 nixie tube of display board displays "F2".

Solution: The tube temperature sensor of air conditioner has not been firmly connected to the controller, please reinsert or replace a tube temperature sensor.

**(5)Error 5: Dual-8 nixie tube of display board displays “H6”.**

Solution: The feedback wire of indoor fan has not been firmly connected to the controller or the indoor fan motor fails to work, please reinsert the feedback line of indoor fan or replace the main board of controller, or replace the motor.

**(6)Error 6: Dul-8 nixie tube of display board displays “FC”.**

Solution: It is malfunction of swing mechanism, which is caused by the looseness of connecting wire or damage of swing mechanism or main board. Please reconnect the connecting wire, or replace the swing mechanism or controller.

**(7)Error 7: Dul-8 nixie tube of display board displays “JF” or “rF”.**

Solution: It is abnormal of detecting board, which is caused by the looseness of communication line between the main board and detecting board, or the malfunction of detecting board or main board. Please reinsert the connecting wire, or replace the detecting board or controller.

**8.Blockage protection to Motor**

(1) When turning on the fan, the motor speed is not more than 300rpm/min for 1 min consecutively, it's blockage protection to motor.

(2)During lockage protection to motor, all load stop operation (indoor fan, outdoor fan, compressor, and electric heating tube stop operation; 4-way valve should delay 2mins to stop operation and then horizontal louver will stop at the current position.

(3)Once there's blockage protection to motor, cut off the power to resume operation.

(4)During blockage protection to motor, remote controller and buttons are valid and they can turn on or turn off the unit, while they won't perform detailed target (indoor fan, outdoor fan, compressor, and electric heating tube stop operation, and 4-way valve should delay 3mins to stop operation; horizontal louver will stop at current position).

(5)During motor blockage protection, if the unit is at on status, the dual-8 nixie tube displayed blockage error code H6; if the unit is at off status, it won't display blockage malfunction information.

**9.Communication malfunction**

If the unit hasn't received correct signal for 3mins consecutively, it's the communication malfunction. Outdoor fan stop operation and stop operation after blowing residual heat under auto heating mode or heating mode. Indoor fan operated at set fan speed under other modes.

**10.Auto inspection function**

Mafunction of jumer cap

After energization, when it's detected the jumper cap outlet is blank, it's the malfunction of jumper cap, which can't resumed. During malfunction protection of jumper cap, if the unit is at on status, the nixie tube displays error code: “C5” and operation indicator is blinking.

If the unit is at off status, it won't display error code.

Note: The controller without this function won't detection this malfunction.

## Outdoor unit

### 09K/13K

#### 1. System function

##### 1.1 Cooling mode

###### 1.1.1 Working condition and process for cooling

When the compressor is at off status, turn on the unit under cooling mode. When indoor unit reaches the condition of turning on the unit, the unit operates under cooling mode. Meanwhile, indoor fan, outdoor fan and compressor stops operation.

###### 1.1.2 Stop operation under cooling mode

Compressor stopped operation, compressor stops operation immediately and outdoor fan delay 30s to stop operation.

###### 1.1.3 Switch to heating mode from cooling mode

When switching to heating mode, 4-way will delay 3min to be energized after compressor is stopped. Others are same with that stopped operation under cooling mode.

###### 1.1.4 4-way valve: 4-way valve will be closed under this mode

###### 1.1.5 Outdoor fan control under cooling mode

After compressor stops operation, outdoor fan will operate at current fan speed for another 30s and then stops operation.

##### 1.2 Drying mode

###### 1.2.1 Working condition and process for drying mode: same with that for cooling mode

###### 1.2.2 Status of 4-way valve: OFF.

###### 1.2.3 Temperature setting range: 16~30°C .

###### 1.2.4 Protection function: Same with that under cooling mode.

###### 1.2.5 The startup condition for electronic expansion valve, outdoor fan and compressor is same as that for cooling mode.

##### 1.3 Heating mode

###### 1.3.1 Working condition and process for heating mode

When indoor unit reaches the startup condition of heating, indoor unit will operate under heating mode.

###### 1.3.2 Stop operation under heating mode:

a. When indoor unit reached OFF or stop operation conditioner, compressor stop operation, and outdoor fan will delay 1min to stop operation.

###### b. Switch to cooling(drying) or fan mode

(a) compressor stops operation; (b) 4-way valve will delay 2min to be de-energized;  
(c) outdoor fan will delayed 30s to stop operation; (d) status of 4-wayvalve: energized.

###### 1.3.3 Outdoor fan control under heating mode

When compressor stops operation, outdoor fan will delay 30s to stop operation.

###### 1.3.4 Defrosting function

When it satisfied defrosting condition, compressor stops operation. After compressor stopped for 30s, outdoor fan stops operation and 4-way valve will change direction; After 4-way valve chaging direction, compressor will be startup, defrosting will start counting time and compressor frquency will be increased to defrosting frequency.

##### 1.4 Fan mode

###### 1.4.1 Compressor, outdoor fan and 4-way valve will all be stopped or closed.

###### 1.4.2 Temperature setting range is 16~30°C .

#### 2. Protection function

##### 2.1 Overload protection function

During cooling mode, measure the temperature of outdoor heat exchanger; during heating mode, measure the temperature of indoor heat exchanger.

(1)When  $T_{\text{tube}} \leq T_1$ , resume original operation status;

(2)When  $T_{\text{tube}} \geq T_2$ , prohibit increasing frequency;

(3)When  $T_{\text{tube}} \geq T_3$ , compressor will decrease frequency to operate.

(4)When  $T_{\text{tube}} \geq T_4$ , compressor stops operation;

During cooling or drying mode:  $T_1=52$ ;  $T_2=55$ ;  $T_3=58$ ;  $T_4=62$ ;

During heating mode:  $T_1=50$ ;  $T_2=53$ ;  $T_3=56$ ;  $T_4=60$ ;

Under auto heating or heating mode, indoor unit will stop operation after blow residual heat. Under other modes, indoor fan operates at set fan speed.

2.2 Delay protection of compressor

When compressor is stopped, it needs 3min to restart up the compressor. Once compressor is started up, compressor won't stop operate within 6in according to the change of temperature.

2.3 Discharge temperature protection of compressor

- (1)When TBdischarge  $B \geq 98^{\circ}\text{C}$  , prohibit increasing frequency;
- (2)When TBdischarge  $B \geq 103^{\circ}\text{C}$  , prohibit decreasing frequency;
- (3)When TBdischarge  $B \geq 110^{\circ}\text{C}$  , compressor stops operation;
- (4)When TBdischarge  $B \leq 90^{\circ}\text{C}$  , protection is released.

2.4 Communication malfunction

When the unit hasn't received correct signal for 3mins consecutively, it's the communication malfunction. The complete unit will stop operation.

2.5 Module protection

During module protection, compressor stops operation. When compressor has stopped operation for 3min, compressor will resume operation. When module protection occurs all the time when starting up compressor for 6 times consecutively, compressor can't be started any more (turn off the unit with remote controller can clear up module, and the accumulative times of module protection). When the operation time of compressor is more than 6mins, the accumulative times will be cleared up.

2.6 When DC bus voltage is lower than 150V or more than 420V, compressor will delay 30s to stop operation. When DC bus voltage is more than 200C and less than 400V, protection will be resumed. Compressor will resume operation after it has stopped for 3mins. During low pressure protection, main relay will break off. When low voltage protection is resumed, main relay will be closed.

2.7 When overload malfunction is occurred, compressor stopped operation and outdoor fan will delay 30s to stop operation; when malfunction is cleared up and compressor has stopped for 3min, the unit will resume operation.

2.8 Power protection of compressor

- (1)When  $\text{PCB} \geq 1500\text{w}$ , prohibit increasing frequency;
- (2)When  $\text{PCB} \geq 1600\text{w}$ , decrease frequency to operate;
- (3)When  $\text{PCB} \geq 1700\text{w}$ , compressor stops operation;
- (4)When  $\text{PCB} \leq 1400\text{w}$ , protection is released.

2.9 Malfunction of temperature sensor

| Name of temperature sensor | Malfunction condition                                                                                                                       |
|----------------------------|---------------------------------------------------------------------------------------------------------------------------------------------|
| Outdoor ambient            | It's detected that the temperature sensor is open/short-circuited for 5s consecutively                                                      |
| Outdoor tube temperature   | It's detected that the temperature sensor is open/short-circuited for 5s consecutively; it won't be detected within 10mins after defrosting |
| Air discharge              | After compressor operates for 3min,it's detected that the temperature sensor is open/short-circuited for 5s consecutively                   |

2.10 When outdoor fan is open-circuited or current is more than 0.8aA, outdoor fan will stop operation and then be restarted up 4s later. If the fan stops operation for 6 times successively, it's the malfunction of fan. And then compressor will stops operation. 3mins later, the malfunction of fan will be cleared and restart up outdoor fan and compressor. If malfunction of fan occurs for 6 times successively, outdoor fan won't be restarted up. Turn off the unit with remote controller can clear up malfunction and the accumulated timer of malfunction. After compressor operates for 6mins successively, the accumulated malfunction times of fan will be cleared.

## 18K

## 1. Compensation function of input parameters

According to the structure of wall-mounting unit, considering the comfortability for operation, indoor ambient temperature when the compressor is at OFF status is higher than set temperature under heating mode.

## 2. Control of detecting the availability of parameters

For ensuring the safety and reliability of operation, please insert the outdoor discharge temperature sensor into the corresponding temperature sensor bushing to make sure that the control system can detect system discharge temperature accurately. Otherwise, the unit will stop operation and it displays malfunction of discharge temperature sensor (discharge temperature sensor hasn't been inserted well), which can only be resumed by pressing ON/OFF button on remote controller. Basic functions:

## 3. Cooling mode

## 3.1 Working condition and process for cooling

3.1.1 If compressor is at OFF status, and  $(T_{\text{preset}} - (T_{\text{indoor amb.}} - \Delta T_{\text{indoor amb. compensation of cooling}})) \leq 0^{\circ}\text{C}$ , the unit operates in cooling mode;

3.1.2 During cooling operation, if  $0^{\circ}\text{C} \leq (T_{\text{preset}} - (T_{\text{indoor amb.}} - \Delta T_{\text{indoor amb. compensation of cooling}})) < 3^{\circ}\text{C}$ , the unit still operates in cooling mode;

3.1.3 During cooling operation, if  $3^{\circ}\text{C} \leq (T_{\text{preset}} - (T_{\text{indoor amb.}} - \Delta T_{\text{indoor amb. compensation of cooling}}))$ , the unit stops operation when reaching the temperature point in cooling.

## 3.2 Temperature setting range:

3.2.1 If  $T_{\text{outdoor amb.}} \geq T_{\text{cooling temperature (low temperature)}}$ , the temperature setting range is 16-30°C (cooling in room temperature);

3.2.2 If  $T_{\text{outdoor amb.}} < T_{\text{cooling temperature (low temperature)}}$ , the temperature setting range is 25-30°C. That is: the lower limit of set temperature for outdoor unit is 25°C.

## 4. Dry mode

4.1 Working conditioner and process for drying is same as that for cooling mode;

4.2 Temperature setting range is 16-30°C;

## 5. Fan mode

5.1 Compressor, outdoor fan and 4-way valve are all turned off;

5.2 Temperature setting range is 16-30°C.

## 6. Heating mode

6.1 Working conditioner and process of heating: ( $T_{\text{indoor amb.}}$  is the actual temperature detected by indoor ambient temperature sensor;  $\Delta T_{\text{indoor amb. compensation of heating}}$  is indoor ambient temperature compensation during heating operation).

6.1.1 If compressor is at OFF status, and  $(T_{\text{indoor amb.}} - \Delta T_{\text{indoor amb. compensation of heating}}) - T_{\text{preset}} \leq -1^{\circ}\text{C}$ , the unit operates in heating mode.

6.1.2 During heating operation, if  $0^{\circ}\text{C} \leq ((T_{\text{indoor amb.}} - \Delta T_{\text{indoor amb. compensation of heating}}) - T_{\text{preset}}) < 2^{\circ}\text{C}$ , the unit still operates in heating mode.

6.1.3 During heating mode, if  $2^{\circ}\text{C} \leq ((T_{\text{indoor amb.}} - \Delta T_{\text{indoor amb. compensation of heating}}) - T_{\text{preset}})$ , the unit stops operation when reaching the temperature point in heating.

6.2 Under this mode, the temperature setting range is 16-30°C.

## 7. Defrosting control (heating mode)

7.1 If it turns to defrosting time and it detected that the defrosting temperature is satisfied for 3mins successively, the unit turns into defrosting process.

7.2 Defrosting-starting: compressor stops operation and restart it up after 55s delayed,

7.3 Defrosting-ending: Compressor stops operation and it starts up after 55s delayed.

7.4 When any one of below defrosting-ending conditions is satisfied, the unit will quit from defrosting operation:

7.4.1  $T_{\text{outdoor tube}} \geq T_{\text{quit temperature 1}}$  for defrosting;

7.4.2 Defrosting operation time is reached  $T_{\text{max. defrosting time}}$ .

## 8. Control of compressor

8.1 Frequency of compressor intangibly controls the frequency according to the relation between ambient temperature and set temperature, and the change speed of ambient temperature;

8.2 Under cooling, heating or drying mode, compressor will be started up after outdoor fan is started for 5s.

8.3 At the OFF status, stop operation because of protection and switchover to fan mode, the compressor stops operation immediately.

8.4 Under each mode: Once the compressor is started up, it can be stopped only after operation.

8.5 Under each mode, once the compressor is stopped, it can be restarted up only after 3min delayed

## 9. Control of outdoor fan

9.1 When turn off the unit by remote controller, stop operation because of protection or stop operation after reaching the temperature point, outdoor fan can stop operation only after the compressor is stopped for 1min;

9.2 Under fan mode: outdoor fan stops operation.

9.3 defrosting-starting: enter into defrosting. Outdoor fan stops operation after compressor stops for 50s.

9.4 Defrosting-ending: quit defrosting. When the compressor stops operation, the outdoor fan operates.

## 10. Control of 4-way valve

10.1 4-way valve status under cooling, drying and fan modes: OFF;

10.2 When the unit turned on and operated in heating mode, the 4-way valve is energized immediately.

10.3 If turn off unit or switch to other mode in heating mode, the 4-way valve is de-energized after the compressor stops for 2min;

10.4 When the unit is turned off because of each protection, the 4-way valve is de-energized after 4 mins delayed.

10.5 Defrosting-starting: enter into defrosting. After the compressor stops for 50s, the 4-way valve will be de-energized.

10.6 Defrosting-ending: quit defrosting. After the compressor stops for 50s, the 4-way valve is energized.

## 11. Freeze protection

11.1 Under cooling or drying mode, if it's detected that  $T_{\text{inner tube}} < 0$  for 3min successively, the unit will stop operation due to freeze protection. If  $T_{\text{limit temperature of freeze protection}} < T_{\text{inner tube}}$ , and compressor stops for 3min, the complete can resume operation;

11.2 Under cooling or drying mode, if  $T_{\text{inner tube}} < 6$ , the operation frequency of compressor may increase or decrease;

11.2.1 If the unit is stopped because of freeze protection for 6 times successively, it can't resume operation automatically and the malfunction will be displayed continuously, which can only be resumed by pressing ON/OFF button. During operation, if operation time of compressor is over, the times of stop operation because of freeze protection will be cleared. If turn off the unit or switch to fan/heating mode, malfunction and times of malfunction is eliminated immediately.

## 12. Overload protection

12.1 Overload protection under cooling or drying mode: If  $T_{\text{overload stop operation temp. in cooling}} \leq T_{\text{outdoor tube}}$ , the unit stops operation because of overload in cooling; if  $T_{\text{outdoor tube}} < T_{\text{overload limit-frequency temp in cooling}}$  and the compressor has stopped for 3min, the complete unit can resume operation.

12.2 Under cooling or drying mode, if  $T_{\text{overload limit-frequency temp. in cooling}} \leq T_{\text{outdoor tube}}$ , the frequency of compressor may increase or decrease;

12.3 Overload protection under heating mode: If  $T_{\text{overload stop operation temp. in heating}} \leq T_{\text{indoor tube}}$ , the unit stops operation because of overload in heating; if  $T_{\text{indoor tube}} < T_{\text{overload limit-frequency temp. in heating}}$  and the compressor has stopped for 3min, the complete unit can resume operation.

12.4 Under heating mode. If  $T_{\text{overload limit-frequency temp. in heating}} \leq T_{\text{indoor tube}}$ , operation frequency of compressor may increase or decrease;

12.5 If the unit is stopped because of overload protection for 6 times successively, it can't resume operation automatically and the malfunction will be displayed continuously, which can only be resumed by pressing ON/OFF button. During operation, if operation time of compressor is over, the times of stop operation because of overload protection will be cleared. If turn off the unit, fan or switch to fan/heating mode, malfunction and times of malfunction is eliminated immediately.

## 13. Discharge temperature protection of compressor

13.1 If  $T_{\text{stop operation temperature for discharge}} \leq T_{\text{discharge}}$ , the unit stops operation because of discharge protection; If  $T_{\text{discharge}} < T_{\text{limit-frequency temperature for discharge}}$  and compressor has stopped for 3min, the complete unit can resume operation;

13.2 If  $T_{\text{normal speed decrease-frequency for discharge}} \leq T_{\text{discharge}}$ , operation frequency of compressor may decrease or increase;

13.3 If the unit is stopped because of discharge protection of compressor for 6 times successively, it can't resume operation automatically, which can only be resumed by pressing ON/OFF button. During operation, if operation time of compressor is over, the times of stop operation because of discharge protection will be cleared. If turn off the unit, or switch to fan/heating mode, malfunction and times of malfunction is eliminated immediately.

## 14. Current protection function

14.1 If  $13A \leq I_{\text{AC current}}$ , operation frequency of compressor may decrease or increase;

14.2 If  $17A \leq I_{\text{AC current}}$ , the system will stop operation because of overcurrent; the complete unit can resume operation only after the compressor stops for 3min;

14.3 If the unit is stopped because of overcurrent for 6 times successively, it can't resume operation automatically, which can only be resumed by pressing ON/OFF button. During operation, if operation time of compressor is over, the times of stop operation because of overcurrent protection will be cleared.

## 15. Voltage drop protection

During operation of compressor, if the voltage is decreasing quickly, the system may stop operation and voltage drop malfunction is caused. 3min later, the system will be restarted up automatically.

## 16. Communication malfunction

When it hasn't received the correct signal from indoor unit for 3min, the unit will stop operation because of communication malfunction; if communication malfunction is eliminated and compressor has stopped for 3min, the complete unit can resume operation.

## 17. OPM module protection

After compressor is turned on, if the overcurrent happens for IPM module, or control voltage is too low because of abnormal causes, IPM will detect module protection signal immediately. Once it detected the module protection signal, the unit will stop operation because of module protection. If module protection is resumed and compressor has stopped for 3min, the complete unit will resume operation.

If the unit is stopped because of module protection for 3 times successively, the unit can resume operation automatically unless press ON/OFF button. If the operation time for compressor is over, the times of stop operation because of module protection will be cleared.

## 18. Overheat protection of module

18.1 If  $T_{\text{normal speed frequency-decreasing temp. of module}} \leq T_{\text{module}}$ , the operation frequency of compressor may decrease or increase;

18.2 If  $T_{\text{stop operation temperature of module}} \leq T_{\text{module}}$ , the system will stop operation for protection. If  $T_{\text{module}} < T_{\text{frequency-limiting temperature of module}}$  and compressor has stopped for 3min, the complete unit will resume operation;

18.3 If the unit is stopped because of overheating of compressor module for 6 times successively, it can't resume operation automatically, which can only be resumed by pressing ON/OFF button. During operation, if operation time of compressor is over, the times of stop operation because of compressor overheating protection will be cleared. If turn off the unit, or switch to fan mode, times of malfunction is eliminated immediately.

## 19. Overload protection of compressor

19.1 If it detected that the overload switch for compressor is open for 3min successively, the complete unit will stop operation for protection;

19.2 If overload protection is resumed and compressor has stopped for 3min, the complete unit can resume operation;

19.3 If the unit stops operation because of overload protection for compressor for 3times successively, it can't resume operation automatically, which can only be resumed by pressing ON/OFF button. After compressor has operated for 30min, overload protection times for compressor will be eliminated.

# Part II : Installation and Maintenance

## 7. Notes for Installation and Maintenance

### Safety Precautions: Important!

Please read the safety precautions carefully before installation and maintenance.

The following contents are very important for installation and maintenance.

Please follow the instructions below.

- The installation or maintenance must accord with the instructions.
- Comply with all national electrical codes and local electrical codes.
- Pay attention to the warnings and cautions in this manual.
- All installation and maintenance shall be performed by distributor or qualified person.
- All electric work must be performed by a licensed technician according to local regulations and the instructions given in this manual.
- Be caution during installation and maintenance. Prohibit incorrect operation to prevent electric shock, casualty and other accidents.



## Warnings

### Electrical Safety Precautions:

1. Cut off the power supply of air conditioner before checking and maintenance.
2. The air condition must apply specialized circuit and prohibit share the same circuit with other appliances.
3. The air conditioner should be installed in suitable location and ensure the power plug is touchable.
4. Make sure each wiring terminal is connected firmly during installation and maintenance.
5. Have the unit adequately grounded. The grounding wire can't be used for other purposes.
6. Must apply protective accessories such as protective boards, cable-cross loop and wire clip.
7. The live wire, neutral wire and grounding wire of power supply must be corresponding to the live wire, neutral wire and grounding wire of the air conditioner.
8. The power cord and power connection wires can't be pressed by hard objects.
9. If power cord or connection wire is broken, it must be replaced by a qualified person.

10. If the power cord or connection wire is not long enough, please get the specialized power cord or connection wire from the manufacture or distributor. Prohibit prolong the wire by yourself.

11. For the air conditioner without plug, an air switch must be installed in the circuit. The air switch should be all-pole parting and the contact parting distance should be more than 3mm.

12. Make sure all wires and pipes are connected properly and the valves are opened before energizing.

13. Check if there is electric leakage on the unit body. If yes, please eliminate the electric leakage.

14. Replace the fuse with a new one of the same specification if it is burnt down; don't replace it with a cooper wire or conducting wire.

15. If the unit is to be installed in a humid place, the circuit breaker must be installed.

### Installation Safety Precautions:

1. Select the installation location according to the requirement of this manual.(See the requirements in installation part)
2. Handle unit transportation with care; the unit should not be carried by only one person if it is more than 20kg.
3. When installing the indoor unit and outdoor unit, a sufficient fixing bolt must be installed; make sure the installation support is firm.
4. Wear safety belt if the height of working is above 2m.
5. Use equipped components or appointed components during installation.
6. Make sure no foreign objects are left in the unit after finishing installation.

### Refrigerant Safety Precautions:

1. Avoid contact between refrigerant and fire as it generates poisonous gas; Prohibit prolong the connection pipe by welding.
2. Apply specified refrigerant only. Never have it mixed with any other refrigerant. Never have air remain in the refrigerant line as it may lead to rupture or other hazards.
3. Make sure no refrigerant gas is leaking out when installation is completed.
4. If there is refrigerant leakage, please take sufficient measure to minimize the density of refrigerant.
5. Never touch the refrigerant piping or compressor without wearing glove to avoid scald or frostbite.

Improper installation may lead to fire hazard, explosion, electric shock or injury.

## Main Tools for Installation and Maintenance

|                                                                                                                          |                                                                                                                           |                                                                                                                                                    |
|--------------------------------------------------------------------------------------------------------------------------|---------------------------------------------------------------------------------------------------------------------------|----------------------------------------------------------------------------------------------------------------------------------------------------|
| <p>1. Level meter, measuring tape</p>   | <p>2. Screw driver</p>                   | <p>3. Impact drill, drill head, electric drill</p>               |
| <p>4. Electroprobe</p>                  | <p>5. Universal meter</p>                | <p>6. Torque wrench, open-end wrench, inner hexagon spanner</p>  |
| <p>7. Electronic leakage detector</p>  | <p>8. Vacuum pump</p>                  | <p>9. Pressure meter</p>                                       |
| <p>10. Pipe pliers, pipe cutter</p>   | <p>11. Pipe expander, pipe bender</p>  | <p>12. Soldering appliance, refrigerant container</p>          |

## 8. Installation

### 8.1 Installation Dimension Diagram

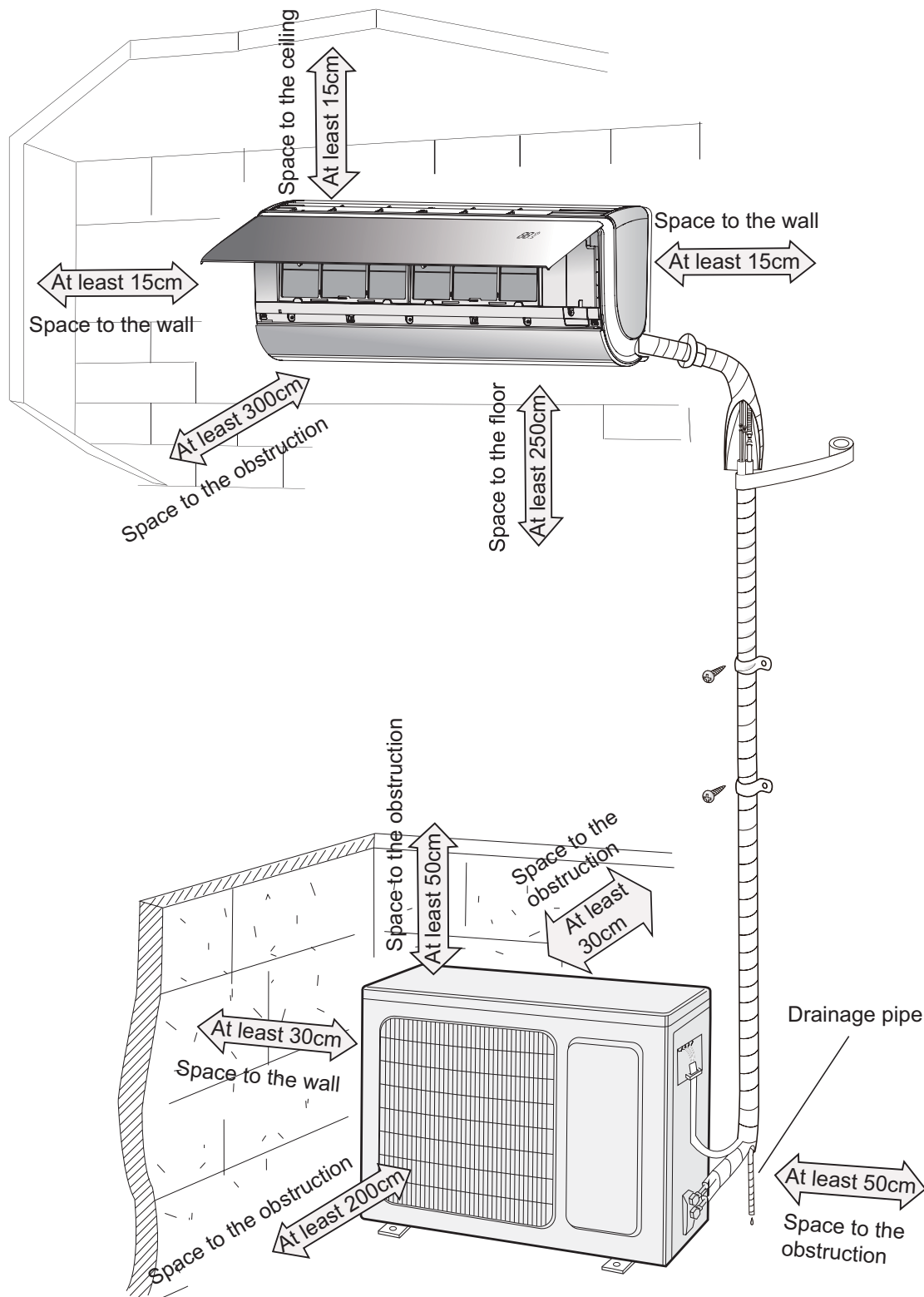

## Installation procedures

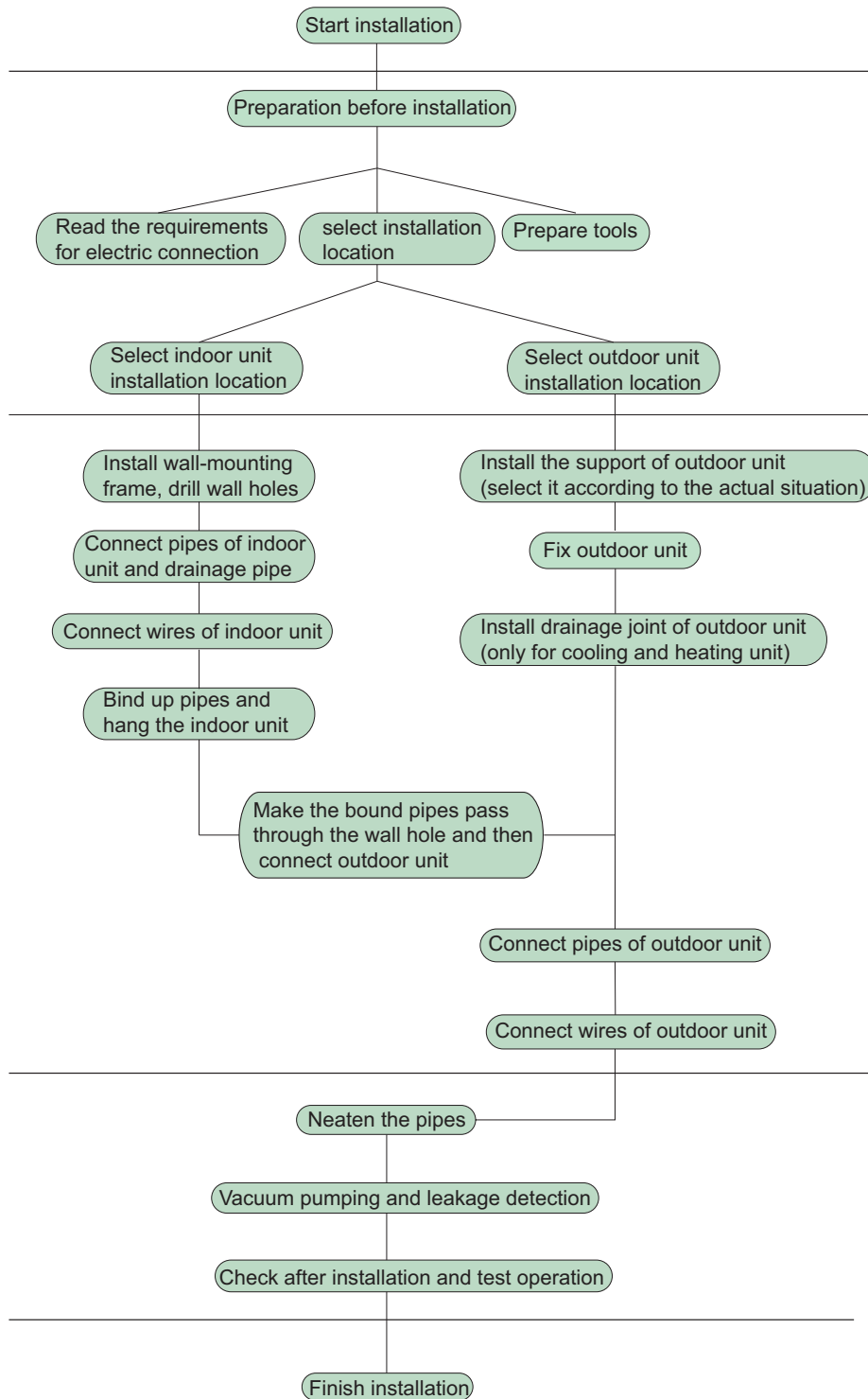

Note: this flow is only for reference; please find the more detailed installation steps in this section.

## 8.2 Installation Parts-checking

| NO. | Name                         | NO. | Name                                    |
|-----|------------------------------|-----|-----------------------------------------|
| 1   | Indoor unit                  | 8   | Sealing gum                             |
| 2   | Outdoor unit                 | 9   | Wrapping tape                           |
| 3   | Connection pipe              | 10  | Support of outdoor unit                 |
| 4   | Drainage pipe                | 11  | Fixing screw                            |
| 5   | Wall-mounting frame          | 12  | Drainage plug(cooling and heating unit) |
| 6   | Connecting cable(power cord) | 13  | Owner's manual, remote controller       |
| 7   | Wall pipe                    |     |                                         |

### ⚠ Note:

- 1.Please contact the local agent for installation.
- 2.Don't use unqualified power cord.

## 8.3 Selection of Installation Location

### 1. Basic Requirement:

Installing the unit in the following places may cause malfunction. If it is unavoidable, please consult the local dealer:

- (1) The place with strong heat sources, vapors, flammable or explosive gas, or volatile objects spread in the air.
- (2) The place with high-frequency devices (such as welding machine, medical equipment).
- (3) The place near coast area.
- (4) The place with oil or fumes in the air.
- (5) The place with sulfureted gas.
- (6) Other places with special circumstances.

### 2. Indoor Unit:

- (1) There should be no obstruction near air inlet and air outlet.
- (2) Select a location where the condensation water can be dispersed easily and won't affect other people.
- (3) Select a location which is convenient to connect the outdoor unit and near the power socket.
- (4) Select a location which is out of reach for children.
- (5) The location should be able to withstand the weight of indoor unit and won't increase noise and vibration.
- (6) The appliance must be installed 250 cm above floor.
- (7) Don't install the indoor unit right above the electric appliance.
- (8) The appliance shall not be installed in the laundry.

### 3. Outdoor Unit:

- (1) Select a location where the noise and outflow air emitted by the outdoor unit will not affect neighborhood.
- (2) The location should be well ventilated and dry, in which the outdoor unit won't be exposed directly to sunlight or strong wind.
- (3) The location should be able to withstand the weight of outdoor unit.
- (4) Make sure that the installation follows the requirement of installation dimension diagram.
- (5) Select a location which is out of reach for children and far away from animals or plants.If it is unavoidable, please add fence for safety purpose.

## 8.4 Electric Connection Requirement

### 1. Safety Precaution

- (1) Must follow the electric safety regulations when installing the unit.
- (2) According to the local safety regulations, use qualified power supply circuit and air switch.
- (3) Make sure the power supply matches with the requirement of air conditioner. Unstable power supply or incorrect wiring may result in electric shock,fire hazard or malfunction. Please install proper power supply cables before using the air conditioner.

| Air-conditioner | Air switch capacity |
|-----------------|---------------------|
| 13K/18K         | 16A                 |

- (4) Properly connect the live wire, neutral wire and grounding wire of power socket.
- (5) Be sure to cut off the power supply before proceeding any work related to electricity and safety.
- (6) Do not put through the power before finishing installation.
- (7) For appliances with type Y attachment,the instructions shall contain the substance of thefollowing.If the supply cord is damaged,it must be replaced by the manufacturer,its service agent or similarly qualified persons in order to avoid a hazard.
- (8) The temperature of refrigerant circuit will be high, please keep the interconnection cable away from the copper tube.

### 2. Grounding Requirement:

- (1) The air conditioner is first class electric appliance. It must be properly grounding with specialized grounding device by a professional. Please make sure it is always grounded effectively, otherwise it may cause electric shock.
- (2) The yellow-green wire in air conditioner is grounding wire, which can't be used for other purposes.
- (3) The grounding resistance should comply with national electric safety regulations.
- (4) The appliance must be positioned so that the plug is accessible.
- (5) An all-pole disconnection switch having a contact separation of at least 3mm in all poles should be connected in fixed wiring.
- (6) Including an air switch with suitable capacity, please note the following table. Air switch should be included magnet buckle and heating buckle function, it can protect the circuit-short and overload. (Caution: please do not use the fuse only for protect the circuit)

## 8.5 Installation of Indoor Unit

### 1. Choosing Installation location

Recommend the installation location to the client and then confirm it with the client.

### 2. Install Wall-mounting Frame

- (1) Hang the wall-mounting frame on the wall; adjust it in horizontal position with the level meter and then point out the screw fixing holes on the wall.
- (2) Drill the screw fixing holes on the wall with impact drill (the specification of drill head should be the same as the plastic expansion particle) and then fill the plastic expansion particles in the holes.

(3) Fix the wall-mounting frame on the wall with tapping screws (ST4.2X25TA) and then check if the frame is firmly installed by pulling the frame. If the plastic expansion particle is loose, please drill another fixing hole nearby.

### 3. Install Wall-mounting Frame

(1) Choose the position of piping hole according to the direction of outlet pipe. The position of piping hole should be a little lower than the wall-mounted frame.(As show in Fig.1)

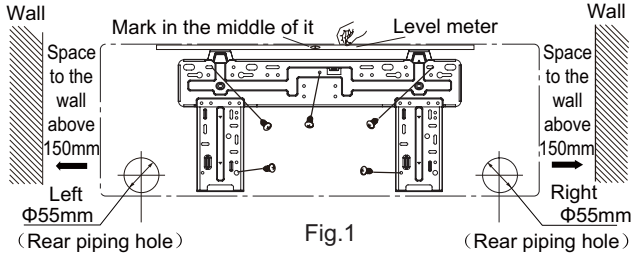

(2) Open a piping hole with the diameter of Φ55mm on the selected outlet pipe position. In order to drain smoothly, slant the piping hole on the wall slightly downward to the outdoor side with the gradient of 5-10°. (As show in Fig.2)

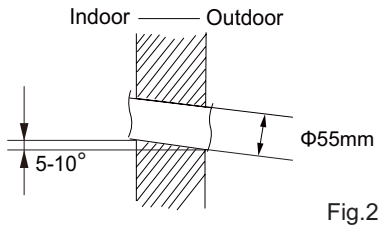

**⚠ Note:**

- (1) Pay attention to dust prevention and take relevant safety measures when opening the hole.
- (2) The plastic expansion particles are not provided and should be bought locally.

### 4. Outlet Pipe

(1) The pipe can be led out in the direction of right, rear right, left or rear left.(As show in Fig.3)

(2) When selecting leading out the pipe from left or right, please cut off the corresponding hole on the bottom case.(As show in Fig.4)

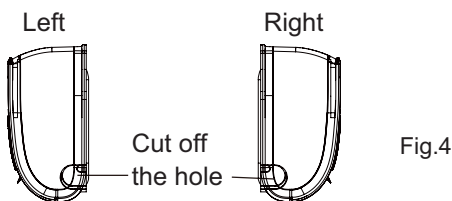
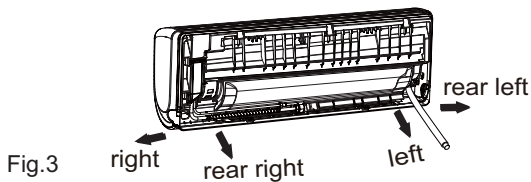

### 5. Connect the Pipe of Indoor Unit

- (1) Aim the pipe joint at the corresponding bellmouth.(As show in Fig.5)
- (2) Pretightening the union nut with hand.
- (3) Adjust the torque force by referring to the following sheet. Place the open-end wrench on the pipe joint and place the torque wrench on the union nut. Tighten the union nut with torque wrench.(As show in Fig.6)
- (4) Wrap the indoor pipe and joint of connection pipe with insulating pipe, and then wrap it with tape.(As show in Fig.7)

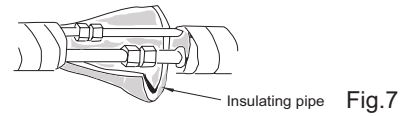
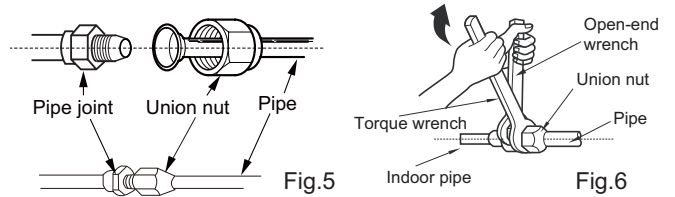

Refer to the following table for wrench moment of force :

| Hex nut diameter(mm) | Tightening torque(N·m) |
|----------------------|------------------------|
| Φ6                   | 15~20                  |
| Φ9.52                | 30~40                  |
| Φ12                  | 45~55                  |
| Φ16                  | 60~65                  |
| Φ19                  | 70~75                  |

### 6. Install Drain Hose

- (1) Connect the drain hose to the outlet pipe of indoor unit.(As show in Fig.8)
- (2) Bind the joint with tape.(As show in Fig.9)

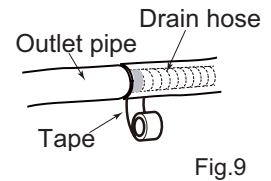
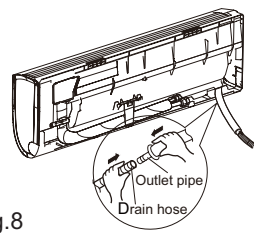

Fig.8

Fig.9

**⚠ Note:**

- (1) Add insulating pipe in the indoor drain hose in order to prevent condensation.
- (2) The plastic expansion particles are not provided. (As show in Fig.10)

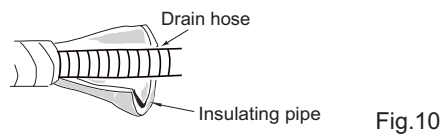
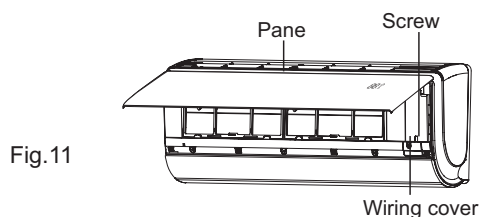

Fig.10

### 7. Connect Wire of Indoor Unit

(1) Open the panel, remove the screw on the wiring cover and then take down the cover.(As show in Fig.11)



(2) Make the power connection wire go through the cable-cross hole at the back of indoor unit and then pull it out from the front side.(As show in Fig.12)

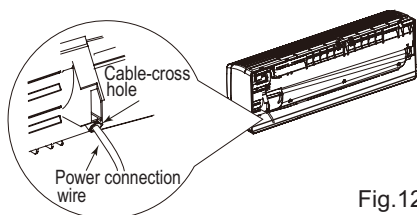

(3) Remove the wire clip; connect the power connection wire to the wiring terminal according to the color; tighten the screw and then fix the power connection wire with wire clip.After finishing wiring of 18K unit, clamp the grounding wire (yellow-green wire) into the wire-crossing groove(As show in Fig.13), in order to avoid pressing the wire when closing the electric box cover.(As show in Fig.13)

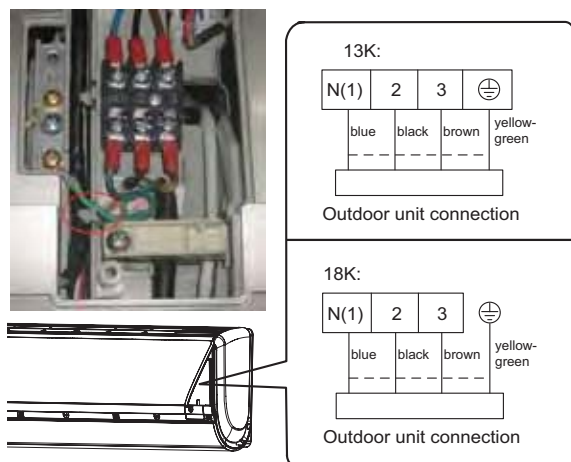

Fig.13

4.Put wiring cover back and then tighten the screw.  
5.Close the panel.

#### ⚠ Note:

- (1) All wires of indoor unit and outdoor unit should be connected by a professional.
- (2) If the length of power connection wire is insufficient, please contact the supplier for a new one. Avoid extending the wire by yourself.
- (3) For the air conditioner with plug, the plug should be reachable after finishing installation.
- (4) For the air conditioner without plug, an air switch must be installed in the line. The air switch should be all-pole parting and the contact parting distance should be more than 3mm.

### 8. Bind up Pipe

- (1) Bind up the connection pipe, power cord and drain hose with the band.(As show in Fig.14)
- (2) Reserve a certain length of drain hose and power cord for installation when binding them. When binding to a certain degree, separate the indoor power and then separate the drain hose.(As show in Fig.15)
- (3) Bind them evenly.
- (4) The liquid pipe and gas pipe should be bound separately at the end.

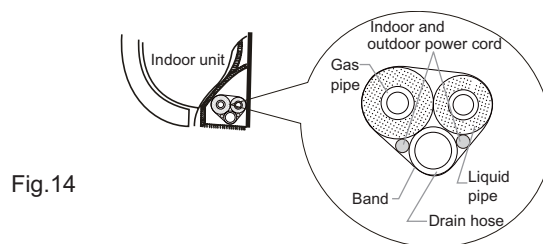

Fig.14

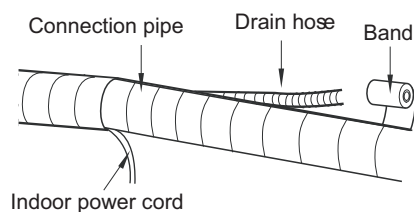

Fig.15

#### ⚠ Note:

- (1) The power cord and control wire can't be crossed or winding.
- (2) The drain hose should be bound at the bottom.

### 9. Hang the Indoor Unit

- (1) Put the bound pipes in the wall pipe and then make them pass through the wall hole.
- (2) Hang the indoor unit on the wall-mounting frame.
- (3) Stuff the gap between pipes and wall hole with sealing gum.
- (4) Fix the wall pipe.(As show in Fig.16)
- (5) Check if the indoor unit is installed firmly and closed to the wall.(As show in Fig.17)

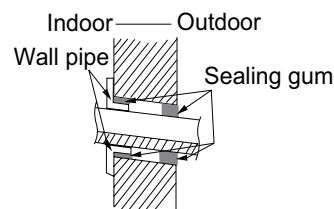

Fig.16

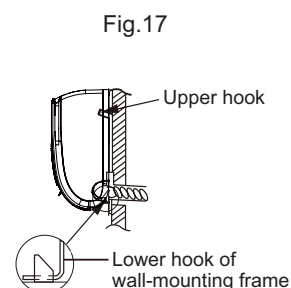

Fig.17

#### ⚠ Note:

Do not bend the drain hose too excessively in order to prevent blocking.

## 8.6 Installation of Outdoor Unit

### 1. Fix the Support of Outdoor Unit(Select it according to the actual installation situation)

- (1) Select installation location according to the house structure.
- (2) Fix the support of outdoor unit on the selected location with expansion screws.

**⚠ Note:**

- (1) Take sufficient protective measures when installing the outdoor unit.
- (2) Make sure the support can withstand at least four times the unit weight.
- (3) The outdoor unit should be installed at least 3cm above the floor in order to install drain joint.(As show in Fig.18)
- (4) For the unit with cooling capacity of 2300W~5000W, 6 expansion screws are needed; for the unit with cooling capacity of 6000W~8000W, 8 expansion screws are needed; for the unit with cooling capacity of 10000W~16000W, 10 expansion screws are needed.

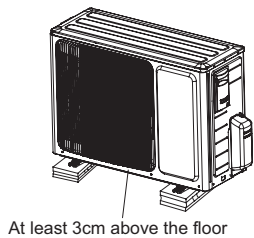

Fig.18

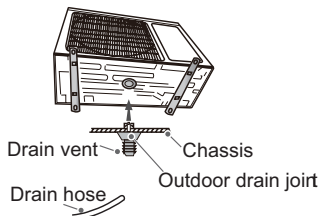

Fig.19

### 2. Install Drain Joint(Only for cooling and heating unit)

- (1) Connect the outdoor drain joint into the hole on the chassis.
  - (2) Connect the drain hose into the drain vent.
- (As show in Fig.19)

### 3. Fix Outdoor Unit

- (1) Place the outdoor unit on the support.
  - (2) Fix the foot holes of outdoor unit with bolts.
- (As show in Fig.20)

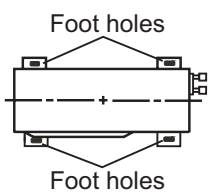

Fig.20

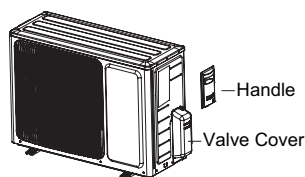

Fig.21

### 4. Connect Indoor and Outdoor Pipes

- (1) Remove the screw on the right handle and valve cover of outdoor unit and then remove the handle and valve cover.(As show in Fig.21)
- (2) Remove the screw cap of valve and aim the pipe joint at the bellmouth of pipe.(As show in Fig.22)

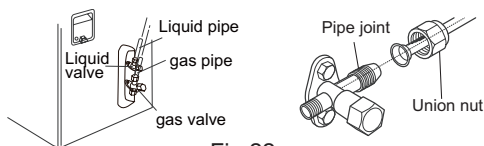

Fig.22

- (3) Pretightening the union nut with hand.
- (4) Tighten the union nut with torque wrench .

Refer to the following table for wrench moment of force :

| Hex nut diameter(mm) | Tightening torque(N·m) |
|----------------------|------------------------|
| Φ6                   | 15~20                  |
| Φ9.52                | 30~40                  |
| Φ12                  | 45~55                  |
| Φ16                  | 60~65                  |
| Φ19                  | 70~75                  |

### 5. Connect Outdoor Electric Wire

- (1) Remove the wire clip; connect the power connection wire and power cord to the wiring terminal according to the color ; fix the them with screws.(As show in Fig.23)

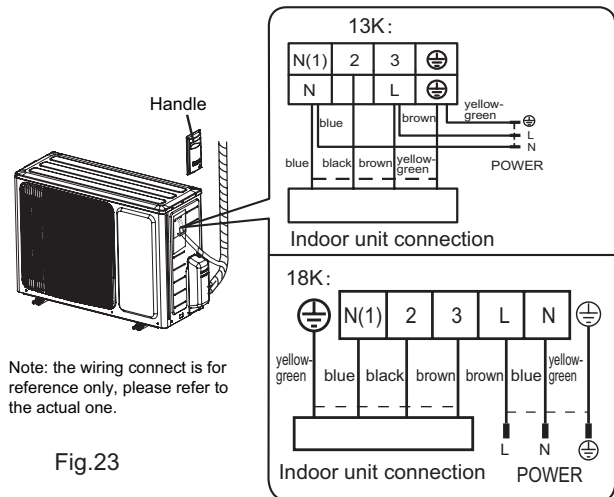

Fig.23

- (2) Fix the power connection wire and power cord with wire clip.

**⚠ Note:**

- (1) After tightening the screw, pull the power cord slightly to check if it is firm.
- (2) Never cut the power connection wire to prolong or shorten the distance.

### 6. Neaten the Pipes

- (1) The pipes should be placed along the wall, bent reasonably and hidden possibly. Min. semidiameter of bending the pipe is 10cm.
- (2) If the outdoor unit is higher than the wall hole, you must set a U-shaped curve in the pipe before pipe goes into the room, in order to prevent rain from getting into the room.(As show in Fig.24)

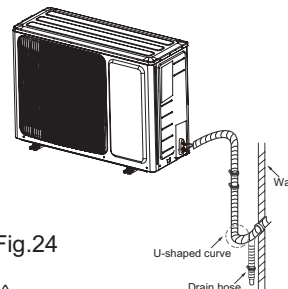

Fig.24

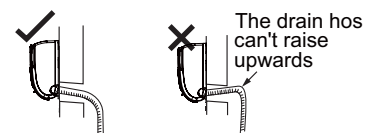
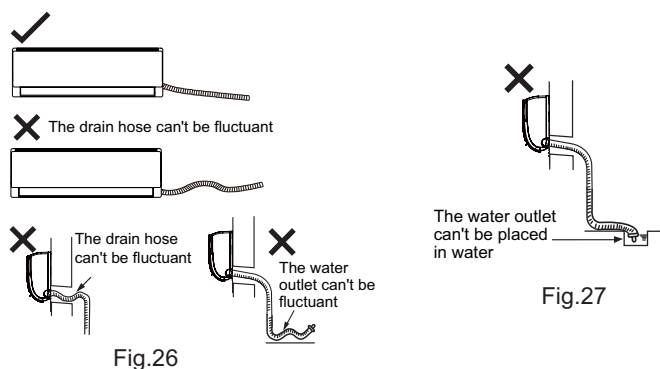

Fig.25

**⚠ Note:**

- (1) The through-wall height of drain hose shouldn't be higher than the outlet pipe hole of indoor unit.(As show in Fig.25)
- (2) Slant the drain hose slightly downwards. The drain hose can't be curved, raised and fluctuant, etc.(As show in Fig.26)

(3) The water outlet can't be placed in water in order to drain smoothly.(As show in Fig.27)



## 8.7 Vacuum Pumping and Leak Detection

### 1. Use Vacuum Pump

- (1) Remove the valve caps on the liquid valve and gas valve and the nut of refrigerant charging vent.
- (2) Connect the charging hose of piezometer to the refrigerant charging vent of gas valve and then connect the other charging hose to the vacuum pump.
- (3) Open the piezometer completely and operate for 10-15min to check if the pressure of piezometer remains in -0.1MPa.
- (4) Close the vacuum pump and maintain this status for 1-2min to check if the pressure of piezometer remains in -0.1MPa. If the pressure decreases, there may be leakage.
- (5) Remove the piezometer, open the valve core of liquid valve and gas valve completely with inner hexagon spanner.
- (6) Tighten the screw caps of valves and refrigerant charging vent.(As show in Fig.28)

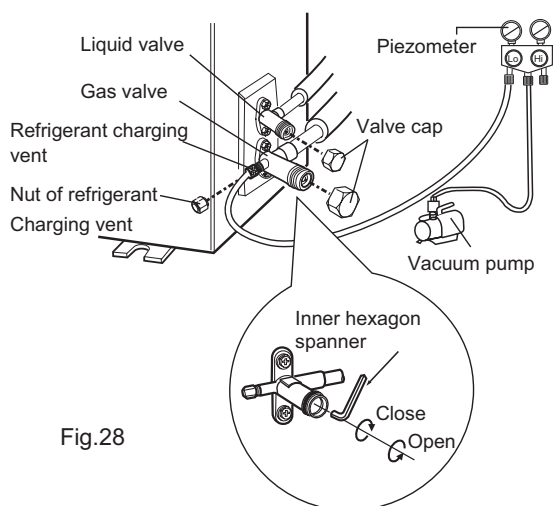

## 8.8 Check after Installation and Test Operation

### 1. Check after Installation

Check according to the following requirement after finishing installation.

| NO. | Items to be checked                                                              | Possible malfunction                                  |
|-----|----------------------------------------------------------------------------------|-------------------------------------------------------|
| 1   | Has the unit been installed firmly?                                              | The unit may drop, shake or emit noise.               |
| 2   | Have you done the refrigerant leakage test?                                      | It may cause insufficient cooling (heating) capacity. |
| 3   | Is heat insulation of pipeline sufficient?                                       | It may cause condensation and water dripping.         |
| 4   | Is water drained well?                                                           | It may cause condensation and water dripping.         |
| 5   | Is the voltage of power supply according to the voltage marked on the nameplate? | It may cause malfunction or damage the parts.         |
| 6   | Is electric wiring and pipeline installed correctly?                             | It may cause malfunction or damage the parts.         |
| 7   | Is the unit grounded securely?                                                   | It may cause electric leakage.                        |
| 8   | Does the power cord follow the specification?                                    | It may cause malfunction or damage the parts.         |
| 9   | Is there any obstruction in air inlet and air outlet?                            | It may cause insufficient cooling (heating).          |
| 10  | The dust and sundries caused during installation are removed?                    | It may cause malfunction or damaging the parts.       |
| 11  | The gas valve and liquid valve of connection pipe are open completely?           | It may cause insufficient cooling (heating) capacity. |

### 2. Test Operation

(1) Preparation of test operation

- The client approves the air conditioner installation.
- Specify the important notes for air conditioner to the client.

(2) Method of test operation

- Put through the power, press ON/OFF button on the remote controller to start operation.
- Press MODE button to select AUTO, COOL, DRY, FAN and HEAT to check whether the operation is normal or not.
- If the ambient temperature is lower than 16°C , the air conditioner can't start cooling.

### 2. Leakage Detection

(1) With leakage detector:

Check if there is leakage with leakage detector.

(2) With soap water:

If leakage detector is not available, please use soap water for leakage detection. Apply soap water at the suspected position and keep the soap water for more than 3min. If there are air bubbles coming out of this position, there's a leakage.

## 9. Maintenance

### 9.1 Error Code List

| NO. | Malfunction Name                                           | Display Method of Indoor Unit |                                                           |                | Display Method of Outdoor Unit |                                                                                   |                          | A/C status | Possible Causes                                                                                                                                  |                                                                                                                                                                                                                                                          |
|-----|------------------------------------------------------------|-------------------------------|-----------------------------------------------------------|----------------|--------------------------------|-----------------------------------------------------------------------------------|--------------------------|------------|--------------------------------------------------------------------------------------------------------------------------------------------------|----------------------------------------------------------------------------------------------------------------------------------------------------------------------------------------------------------------------------------------------------------|
|     |                                                            | Dual-8 Code Display           | Indicator Display (during blinking, ON 0.5s and OFF 0.5s) |                |                                | Indicator has 3 kinds of display status and during blinking, ON 0.5s and OFF 0.5s |                          |            |                                                                                                                                                  |                                                                                                                                                                                                                                                          |
|     |                                                            |                               | Operation Indicator                                       | Cool Indicator | Heating Indicator              | Yellow Indicator                                                                  | Red Indicator            |            |                                                                                                                                                  | Green Indicator                                                                                                                                                                                                                                          |
| 1   | High pressure protection of system                         | E1                            |                                                           |                |                                |                                                                                   |                          |            | During cooling and drying operation, except indoor fan operates, all loads stop operation.<br>During heating operation, the complete unit stops. | Possible reasons:<br>1. Refrigerant was superabundant;<br>2. Poor heat exchange (including filth blockage of heat exchanger and bad radiating environment );<br>Ambient temperature is too high.                                                         |
| 2   | Antifreezing protection                                    | E2                            |                                                           |                |                                | OFF 1S and blink 3 times                                                          |                          |            | During cooling and drying operation, compressor and outdoor fan stop while indoor fan operates.                                                  | 1. Poor air-return in indoor unit;<br>2. Fan speed is abnormal;<br>3. Evaporator is dirty.                                                                                                                                                               |
| 3   | Refrigerant leakage protection                             | F0                            |                                                           |                |                                |                                                                                   | OFF 1S and blink 9 times |            | The Dual-8 Code Display will show F0 and the complete unit stops.                                                                                | 1.Refrigerant leakage;<br>2.Indoor evaporator temperature sensor works abnormally;<br>3.The unit has been plugged up somewhere.                                                                                                                          |
| 4   | High discharge temperature protection of compressor        | E4                            |                                                           |                |                                | OFF 1S and blink 7 times                                                          |                          |            | During cooling and drying operation, compressor and outdoor fan stop while indoor fan operates. During heating operation, all loads stop.        | Please refer to the malfunction analysis (discharge protection, overload).                                                                                                                                                                               |
| 5   | Overcurrent protection                                     | E5                            |                                                           |                |                                | OFF 1S and blink 5 times                                                          |                          |            | During cooling and drying operation, compressor and outdoor fan stop while indoor fan operates. During heating operation, all loads stop.        | 1. Supply voltage is unstable;<br>2. Supply voltage is too low and load is too high;<br>3. Evaporator is dirty.                                                                                                                                          |
| 6   | Communication Malfunction                                  | E6                            |                                                           |                |                                | Always                                                                            |                          |            | During cooling operation, compressor stops while indoor fan motor operates. During heating operation, the complete unit stops.                   | Refer to the corresponding malfunction analysis.                                                                                                                                                                                                         |
| 7   | High temperature resistant protection                      | E8                            |                                                           |                |                                | OFF 1S and blink 6 times                                                          |                          |            | During cooling operation: compressor will stop while indoor fan will operate. During heating operation, the complete unit stops.                 | Refer to the malfunction analysis (overload, high temperature resistant).                                                                                                                                                                                |
| 8   | EEPROM malfunction                                         | EE                            |                                                           |                |                                | OFF 1S and blink 11 times                                                         |                          |            | During cooling and drying operation, compressor will stop while indoor fan will operate; During heating operation, the complete unit will stop   | Replace outdoor control panel AP1                                                                                                                                                                                                                        |
| 9   | Limit/decrease frequency due to high temperature of module | EU                            |                                                           |                |                                |                                                                                   |                          |            | All loads operate normally, while operation frequency for compressor is decreased                                                                | Discharging after the complete unit is de-energized for 20mins, check whether the thermal grease on IPM Module of outdoor control panel AP1 is sufficient and whether the radiator is inserted tightly. If its no use, please replace control panel AP1. |
| 10  | Malfunction protection of jumper cap                       | C5                            |                                                           |                |                                |                                                                                   |                          |            | Wireless remote receiver and button are effective, but can not dispose the related command                                                       | 1. No jumper cap insert on mainboard.<br>2. Incorrect insert of jumper cap.<br>3. Jumper cap damaged.<br>4. Abnormal detecting circuit of mainboard.                                                                                                     |

| NO. | Malfunction Name                                             | Display Method of Indoor Unit |                                                           |                | Display Method of Outdoor Unit |                                                                                   |                          | A/C status | Possible Causes                                                                                                                                                                                                   |                                                                                                                                                                                                                                                                           |
|-----|--------------------------------------------------------------|-------------------------------|-----------------------------------------------------------|----------------|--------------------------------|-----------------------------------------------------------------------------------|--------------------------|------------|-------------------------------------------------------------------------------------------------------------------------------------------------------------------------------------------------------------------|---------------------------------------------------------------------------------------------------------------------------------------------------------------------------------------------------------------------------------------------------------------------------|
|     |                                                              | Dual-8 Code Display           | Indicator Display (during blinking, ON 0.5s and OFF 0.5s) |                |                                | Indicator has 3 kinds of display status and during blinking, ON 0.5s and OFF 0.5s |                          |            |                                                                                                                                                                                                                   |                                                                                                                                                                                                                                                                           |
|     |                                                              |                               | Operation Indicator                                       | Cool Indicator | Heating Indicator              | Yellow Indicator                                                                  | Red Indicator            |            |                                                                                                                                                                                                                   | Green Indicator                                                                                                                                                                                                                                                           |
| 11  | Gathering refrigerant                                        | Fo                            |                                                           |                |                                | OFF 1S and blink 17 times                                                         |                          |            | When the outdoor unit receive signal of Gathering refrigerant ,the system will be forced to run under cooling mode for gathering refrigerant                                                                      | Nominal cooling mode                                                                                                                                                                                                                                                      |
| 12  | Indoor ambient temperature sensor is open/short circuited    | F1                            |                                                           |                |                                |                                                                                   |                          |            | During cooling and drying operation, indoor unit operates while other loads will stop; during heating operation, the complete unit will stop operation.                                                           | 1. Loosening or bad contact of indoor ambient temp. sensor and mainboard terminal.<br>2. Components in mainboard fell down leads short circuit.<br>3. Indoor ambient temp. sensor damaged.(check with sensor resistance value chart)<br>4. Mainboard damaged.             |
| 13  | Indoor evaporator temperature sensor is open/short circuited | F2                            |                                                           |                |                                |                                                                                   |                          |            | AC stops operation once reaches the setting temperature. Cooling, drying; internal fan motor stops operation while other loads stop operation; heating: AC stop operation                                         | 1. Loosening or bad contact of Indoor evaporator temp. sensor and mainboard terminal.<br>2. Components on the mainboard fall down leads short circuit.<br>3. Indoor evaporator temp. sensor damaged.(check temp. sensor value chart for testing)<br>4. Mainboard damaged. |
| 14  | Outdoor ambient temperature sensor is open/short circuited   | F3                            |                                                           |                |                                |                                                                                   | OFF 1S and blink 6 times |            | During cooling and drying operating, compressor stops while indoor fan operates; During heating operation, the complete unit will stop operation                                                                  | Outdoor temperature sensor hasnt been connected well or is damaged. Please check it by referring to the resistance table for temperature sensor)                                                                                                                          |
| 15  | Outdoor condenser temperature sensor is open/short circuited | F4                            |                                                           |                |                                |                                                                                   | OFF 1S and blink 5 times |            | During cooling and drying operation, compressor stops while indoor fan will operate; During heating operation, the complete unit will stop operation.                                                             | Outdoor temperature sensor hasnt been connected well or is damaged. Please check it by referring to the resistance table for temperature sensor)                                                                                                                          |
| 16  | Outdoor discharge temperature sensor is open/short circuited | F5                            |                                                           |                |                                |                                                                                   | OFF 1S and blink 7 times |            | During cooling and drying operation, compressor will sop after operating for about 3 mins, while indoor fan will operate; During heating operation, the complete unit will stop after operating for about 3 mins. | 1.Outdoor temperature sensor hasnt been connected well or is damaged. Please check it by referring to the resistance table for temperature sensor)<br>2.The head of temperature sensor hasnt been inserted into the copper tube                                           |
| 17  | Limit/ decrease frequency due to overload                    | F6                            |                                                           |                |                                |                                                                                   | OFF 1S and blink 3 times |            | All loads operate normally, while operation frequency for compressor is decreased                                                                                                                                 | Refer to the malfunction analysis (overload, high temperature resistant)                                                                                                                                                                                                  |
| 18  | Decrease frequency due to overcurrent                        | F8                            |                                                           |                |                                |                                                                                   | OFF 1S and blink once    |            | All loads operate normally, while operation frequency for compressor is decreased                                                                                                                                 | The input supply voltage is too low; System pressure is too high and overload                                                                                                                                                                                             |

| NO. | Malfunction Name                              | Display Method of Indoor Unit |                                                           |                | Display Method of Outdoor Unit |                                                                                   |                           | A/C status                                                                                                                                                   | Possible Causes                                                                                                                                                                                                                                                                                                                                                                      |                 |
|-----|-----------------------------------------------|-------------------------------|-----------------------------------------------------------|----------------|--------------------------------|-----------------------------------------------------------------------------------|---------------------------|--------------------------------------------------------------------------------------------------------------------------------------------------------------|--------------------------------------------------------------------------------------------------------------------------------------------------------------------------------------------------------------------------------------------------------------------------------------------------------------------------------------------------------------------------------------|-----------------|
|     |                                               | Dual-8 Code Display           | Indicator Display (during blinking, ON 0.5s and OFF 0.5s) |                |                                | Indicator has 3 kinds of display status and during blinking, ON 0.5s and OFF 0.5s |                           |                                                                                                                                                              |                                                                                                                                                                                                                                                                                                                                                                                      |                 |
|     |                                               |                               | Operation Indicator                                       | Cool Indicator | Heating Indicator              | Yellow Indicator                                                                  | Red Indicator             |                                                                                                                                                              |                                                                                                                                                                                                                                                                                                                                                                                      | Green Indicator |
| 19  | Decrease frequency due to high air discharge  | F9                            |                                                           |                |                                |                                                                                   | OFF 1S and blink twice    | All loads operate normally, while operation frequency for compressor is decreased                                                                            | Overload or temperature is too high;<br>Refrigerant is insufficient;<br>Malfunction of electric expansion valve (EKV)                                                                                                                                                                                                                                                                |                 |
| 20  | Limit/ decrease frequency due to antifreezing | FH                            |                                                           |                |                                |                                                                                   | OFF 1S and blink 4 times  | All loads operate normally, while operation frequency for compressor is decreased                                                                            | Poor air-return in indoor unit or fan speed is too low                                                                                                                                                                                                                                                                                                                               |                 |
| 21  | Voltage for DC bus-bar is too high            | PH                            |                                                           |                |                                |                                                                                   | OFF 1S and blink 13 times | During cooling and drying operation, compressor will stop while indoor fan will operate;<br>During heating operation, the complete unit will stop operation. | 1. Measure the voltage of position L and N on wiring board (XT), if the voltage is higher than 265VAC, turn on the unit after the supply voltage is increased to the normal range.<br>2.If the AC input is normal, measure the voltage of electrolytic capacitor C on control panel (AP1), if its normal, theres malfunction for the circuit, please replace the control panel (AP1) |                 |
| 22  | Voltage of DC bus-bar is too low              | PL                            |                                                           |                |                                |                                                                                   | OFF 1S and blink 12 times | During cooling and drying operation, compressor will stop while indoor fan will operate;<br>During heating operation, the complete unit will stop            | 1. Measure the voltage of position L and N on wiring board (XT), if the voltage is higher than 150VAC, turn on the unit after the supply voltage is increased to the normal range.<br>2.If the AC input is normal, measure the voltage of electrolytic capacitor C on control panel (AP1), if its normal, theres malfunction for the circuit, please replace the control panel (AP1) |                 |
| 23  | Compressor Min frequency in test state        | P0                            |                                                           |                |                                |                                                                                   |                           |                                                                                                                                                              | Showing during min. cooling or min. heating test                                                                                                                                                                                                                                                                                                                                     |                 |
| 24  | Compresso r rated frequenc e in test state    | P1                            |                                                           |                |                                |                                                                                   |                           |                                                                                                                                                              | Showing during nominal cooling or nominal heating test                                                                                                                                                                                                                                                                                                                               |                 |
| 25  | Compressor maximum frequency in test state    | P2                            |                                                           |                |                                |                                                                                   |                           |                                                                                                                                                              | Showing during max. cooling or max. heating test                                                                                                                                                                                                                                                                                                                                     |                 |

| NO. | Malfunction Name                                                              | Display Method of Indoor Unit |                                                           |                | Display Method of Outdoor Unit |                                                                                   |               | A/C status                                                                                                                                                | Possible Causes                                                                                                                                                                                                                              |                 |
|-----|-------------------------------------------------------------------------------|-------------------------------|-----------------------------------------------------------|----------------|--------------------------------|-----------------------------------------------------------------------------------|---------------|-----------------------------------------------------------------------------------------------------------------------------------------------------------|----------------------------------------------------------------------------------------------------------------------------------------------------------------------------------------------------------------------------------------------|-----------------|
|     |                                                                               | Dual-8 Code Display           | Indicator Display (during blinking, ON 0.5s and OFF 0.5s) |                |                                | Indicator has 3 kinds of display status and during blinking, ON 0.5s and OFF 0.5s |               |                                                                                                                                                           |                                                                                                                                                                                                                                              |                 |
|     |                                                                               |                               | Operation Indicator                                       | Cool Indicator | Heating Indicator              | Yellow Indicator                                                                  | Red Indicator |                                                                                                                                                           |                                                                                                                                                                                                                                              | Green Indicator |
| 26  | Compressor intermediate frequency in test state                               | P3                            |                                                           |                |                                |                                                                                   |               |                                                                                                                                                           | Showing during middle cooling or middle heating test                                                                                                                                                                                         |                 |
| 27  | Overcurrent protection of phase current for compressor                        | P5                            |                                                           |                |                                |                                                                                   |               | During cooling and drying operation, compressor will stop while indoor fan will operate; During heating operation, the complete unit will stop operation. | Refer to the malfunction analysis (IPM protection, loss of synchronism protection and overcurrent protection of phase current for compressor).                                                                                               |                 |
| 28  | Charging malfunction of capacitor                                             | PU                            |                                                           |                |                                |                                                                                   |               | During cooling and drying operation, compressor will stop while indoor fan will operate; During heating operation, the complete unit will stop            | Refer to the part three—charging malfunction analysis of capacitor                                                                                                                                                                           |                 |
| 29  | Malfunction of module temperature sensor circuit                              | P7                            |                                                           |                |                                |                                                                                   |               | During cooling and drying operation, compressor will stop while indoor fan will operate; During heating operation, the complete unit will stop            | Replace outdoor control panel AP1                                                                                                                                                                                                            |                 |
| 30  | Module high temperature protection                                            | P8                            |                                                           |                |                                |                                                                                   |               | During cooling operation, compressor will stop while indoor fan will operate; During heating operation, the complete unit will stop                       | After the complete unit is de-energized for 20mins, check whether the thermal grease on IPM Module of outdoor control panel AP1 is sufficient and whether the radiator is inserted tightly. If its no use, please replace control panel AP1. |                 |
| 31  | Decrease frequency due to high temperature resistant during heating operation | H0                            |                                                           |                |                                |                                                                                   |               | All loads operate normally, while operation frequency for compressor is decreased                                                                         | Refer to the malfunction analysis (overload, high temperature resistant)                                                                                                                                                                     |                 |
| 32  | Static dedusting protection                                                   | H2                            |                                                           |                |                                |                                                                                   |               |                                                                                                                                                           |                                                                                                                                                                                                                                              |                 |
| 33  | Overload protection for compressor                                            | H3                            |                                                           |                |                                | OFF 1S and blink 8 times                                                          |               | During cooling and drying operation, compressor will stop while indoor fan will operate; During heating operation, the complete unit will stop operation. | 1. Wiring terminal OVC-COMP is loosened. In normal state, the resistance for this terminal should be less than 1ohm.<br>2.Refer to the malfunction analysis (discharge protection, overload)                                                 |                 |

| NO. | Malfunction Name                           | Display Method of Indoor Unit |                                                           |                | Display Method of Outdoor Unit |                                                                                   |                           | A/C status      | Possible Causes                                                                                                                                           |                                                                                                                                                                                                      |
|-----|--------------------------------------------|-------------------------------|-----------------------------------------------------------|----------------|--------------------------------|-----------------------------------------------------------------------------------|---------------------------|-----------------|-----------------------------------------------------------------------------------------------------------------------------------------------------------|------------------------------------------------------------------------------------------------------------------------------------------------------------------------------------------------------|
|     |                                            | Dual-8 Code Display           | Indicator Display (during blinking, ON 0.5s and OFF 0.5s) |                |                                | Indicator has 3 kinds of display status and during blinking, ON 0.5s and OFF 0.5s |                           |                 |                                                                                                                                                           |                                                                                                                                                                                                      |
|     |                                            |                               | Operation Indicator                                       | Cool Indicator | Heating Indicator              | Yellow Indicator                                                                  | Red Indicator             | Green Indicator |                                                                                                                                                           |                                                                                                                                                                                                      |
| 34  | System is abnormal                         | H4                            |                                                           |                |                                | OFF 1S and blink 6 times                                                          |                           |                 | During cooling and drying operation, compressor will stop while indoor fan will operate; During heating operation, the complete unit will stop operation. | Refer to the malfunction analysis (overload, high temperature resistant)                                                                                                                             |
| 35  | IPM protection                             | H5                            |                                                           |                |                                | OFF 1S and blink 4 times                                                          |                           |                 | During cooling and drying operation, compressor will stop while indoor fan will operate; During heating operation, the complete unit will stop operation. | Refer to the malfunction analysis (IPM protection, loss of synchronism protection and overcurrent protection of phase current for compressor.                                                        |
| 36  | Module temperature is too high             | H5                            |                                                           |                |                                | OFF 1S and blink 10 times                                                         |                           |                 |                                                                                                                                                           |                                                                                                                                                                                                      |
| 37  | Internal motor (fan motor) do not operate  | H6                            |                                                           |                |                                |                                                                                   |                           |                 | Internal fan motor, external fan motor, compressor and electric heater stop operation,guide louver stops at present location.                             | 1. Bad contact of DC motor feedback terminal.<br>2. Bad contact of DC motor control end.<br>3. Fan motor is stalling.<br>4. Motor malfunction.<br>5. Malfunction of mainboard rev detecting circuit. |
| 38  | Desynchronizing of compressor              | H7                            |                                                           |                |                                |                                                                                   |                           |                 | During cooling and drying operation, compressor will stop while indoor fan will operate; During heating operation, the complete unit will stop operation. | Refer to the malfunction analysis (IPM protection, loss of synchronism protection and overcurrent protection of phase current for compressor.                                                        |
| 39  | PFC protection                             | HC                            |                                                           |                |                                | OFF 1S and blink 14 times                                                         |                           |                 | During cooling and drying operation, compressor will stop while indoor fan will operate; During heating operation, the complete unit will stop operation. | Refer to the malfunction analysis                                                                                                                                                                    |
| 40  | Outdoor DC fan motor malfunction           | L3                            |                                                           |                |                                |                                                                                   | OFF 1S and blink 14 times |                 | Outdoor DC fan motor malfunction lead to compressor stop operation,                                                                                       | DC fan motor malfunction or system blocked or the connector loosed                                                                                                                                   |
| 41  | power protection                           | L9                            |                                                           |                |                                | OFF 1S and blink 9 times                                                          |                           |                 | compressor stop operation and Outdoor fan motor will stop 30s latter , 3 minutes latter fan motor and compressor will restart                             | To protect the electrical components when detect high power                                                                                                                                          |
| 42  | Indoor unit and outdoor unit doesn't match | LP                            |                                                           |                |                                | OFF 1S and blink 16 times                                                         |                           |                 | compressor and Outdoor fan motor can't work                                                                                                               | Indoor unit and outdoor unit doesn't match                                                                                                                                                           |
| 43  | Failure start-up                           | LC                            |                                                           |                |                                |                                                                                   |                           |                 | During cooling and drying operation, compressor will stop while indoor fan will operate; During heating operation, the complete unit will stop operation. | Refer to the malfunction analysis                                                                                                                                                                    |

| NO. | Malfunction Name                                              | Display Method of Indoor Unit |                                                           |                | Display Method of Outdoor Unit |                                                                                   |                           | A/C status | Possible Causes                                                                                                                                               |                                                                                                                              |
|-----|---------------------------------------------------------------|-------------------------------|-----------------------------------------------------------|----------------|--------------------------------|-----------------------------------------------------------------------------------|---------------------------|------------|---------------------------------------------------------------------------------------------------------------------------------------------------------------|------------------------------------------------------------------------------------------------------------------------------|
|     |                                                               | Dual-8 Code Display           | Indicator Display (during blinking, ON 0.5s and OFF 0.5s) |                |                                | Indicator has 3 kinds of display status and during blinking, ON 0.5s and OFF 0.5s |                           |            |                                                                                                                                                               |                                                                                                                              |
|     |                                                               |                               | Operation Indicator                                       | Cool Indicator | Heating Indicator              | Yellow Indicator                                                                  | Red Indicator             |            |                                                                                                                                                               | Green Indicator                                                                                                              |
| 44  | Malfunction of phase current detection circuit for compressor | U1                            |                                                           |                |                                |                                                                                   |                           |            | During cooling and drying operation, compressor will stop while indoor fan will operate; During heating operation, the complete unit will stop                | Replace outdoor control panel AP1                                                                                            |
| 45  | Malfunction of voltage dropping for DC bus-bar                | U3                            |                                                           |                |                                |                                                                                   |                           |            | During cooling and drying operation, compressor will stop while indoor fan will operate; During heating operation, the complete unit will stop                | Supply voltage is unstable                                                                                                   |
| 46  | Malfunction of complete units current detection               | U5                            |                                                           |                |                                |                                                                                   |                           |            | During cooling and drying operation, the compressor will stop while indoor fan will operate; During heating operating, the complete unit will stop operation. | Theres circuit malfunction on outdoor units control panel AP1, please replace the outdoor units control panel AP1.           |
| 47  | The four-way valve is abnormal                                | U7                            |                                                           |                |                                |                                                                                   |                           |            | If this malfunction occurs during heating operation, the complete unit will stop operation.                                                                   | 1.Supply voltage is lower than AC175V;<br>2.Wiring terminal 4V is loosened or broken;<br>3.4V is damaged, please replace 4V. |
| 48  | Zero-crossing malfunction of outdoor unit                     | U9                            |                                                           |                |                                |                                                                                   |                           |            | During cooling operation, compressor will stop while indoor fan will operate; during heating,the complete unit will stop operation.                           | Replace outdoor control panel AP1                                                                                            |
| 49  | Frequency limiting (power)                                    |                               |                                                           |                |                                |                                                                                   | OFF 1S and blink 13 times |            |                                                                                                                                                               |                                                                                                                              |
| 50  | Compressor running                                            |                               |                                                           |                |                                |                                                                                   | OFF 1S and blink once     |            |                                                                                                                                                               |                                                                                                                              |
| 51  | The temperature for turning on the unit is reached            |                               |                                                           |                |                                |                                                                                   | OFF 1S and blink 8 times  |            |                                                                                                                                                               |                                                                                                                              |
| 52  | Frequency limiting (module temperature)                       |                               |                                                           |                |                                |                                                                                   | OFF 1S and blink 11 times |            |                                                                                                                                                               |                                                                                                                              |

| NO. | Malfunction Name     | Display Method of Indoor Unit |                                                              |                     | Display Method of Outdoor Unit |                   |                                                                                   | A/C status | Possible Causes                                                                                      |                      |
|-----|----------------------|-------------------------------|--------------------------------------------------------------|---------------------|--------------------------------|-------------------|-----------------------------------------------------------------------------------|------------|------------------------------------------------------------------------------------------------------|----------------------|
|     |                      | Dual-8 Code Display           | Indicator Display (during blinking, ON 0.5s and OFF 0.5s)    | Operation Indicator | Cool Indicator                 | Heating Indicator | Indicator has 3 kinds of display status and during blinking, ON 0.5s and OFF 0.5s |            |                                                                                                      | Yellow Indicator     |
| 53  | Normal communication |                               |                                                              |                     |                                |                   |                                                                                   |            | OFF 0.5S and blink once                                                                              |                      |
| 54  | Defrosting           |                               | OFF 3S and blink once (during blinking, ON 10s and OFF 0.5s) |                     |                                |                   | OFF 1S and blink twice                                                            |            | Defrosting will occur in heating mode. Compressor will operate while indoor fan will stop operation. | Its the normal state |

## 9.2 Troubleshooting for Main Malfunction

### Indoor Unit

#### 1. Malfunction of Temperature Sensor F1, F2

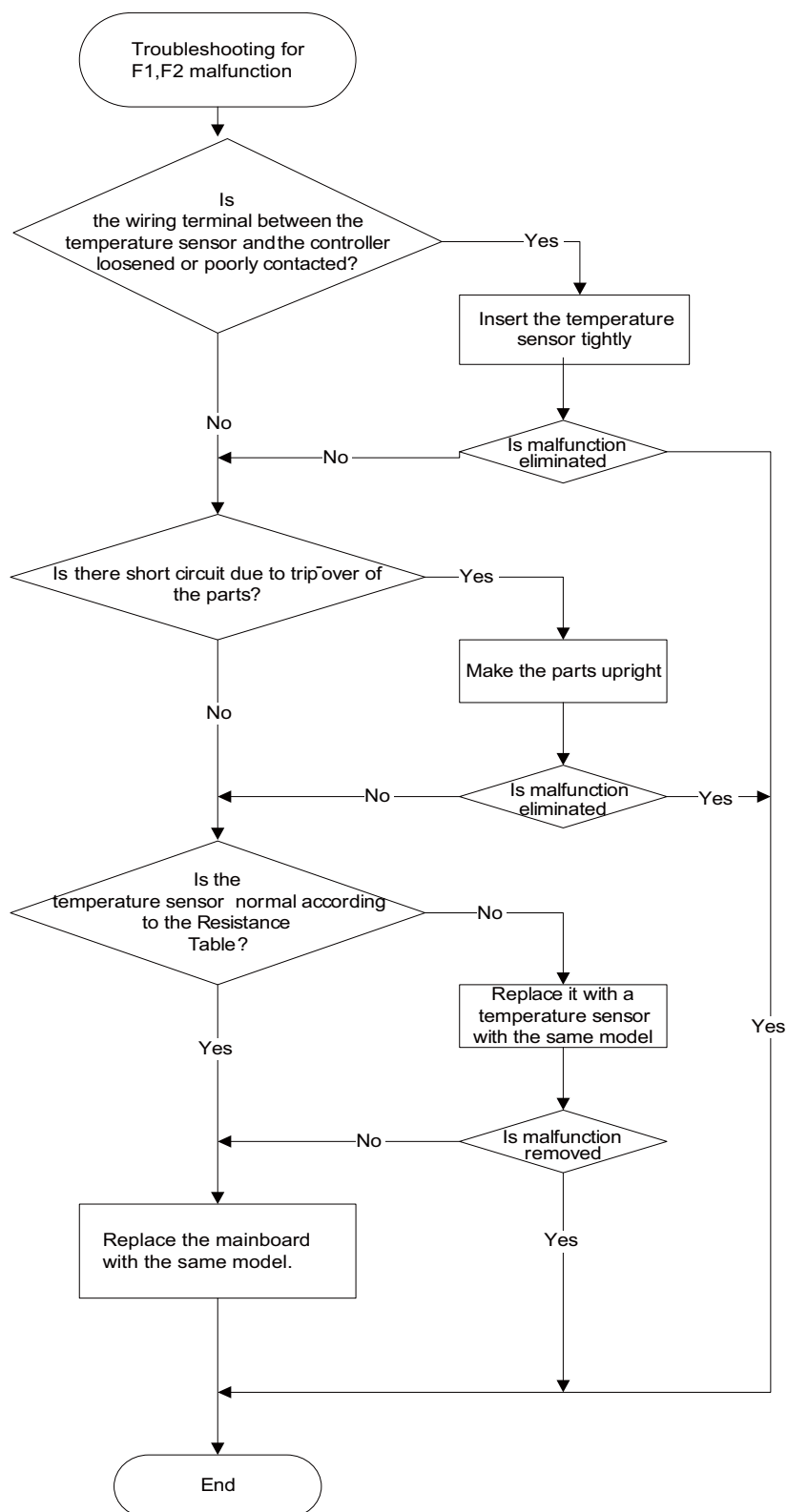

## 2. Malfunction of Blocked Protection of IDU Fan Motor H6

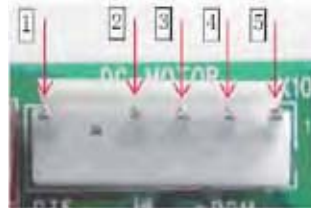
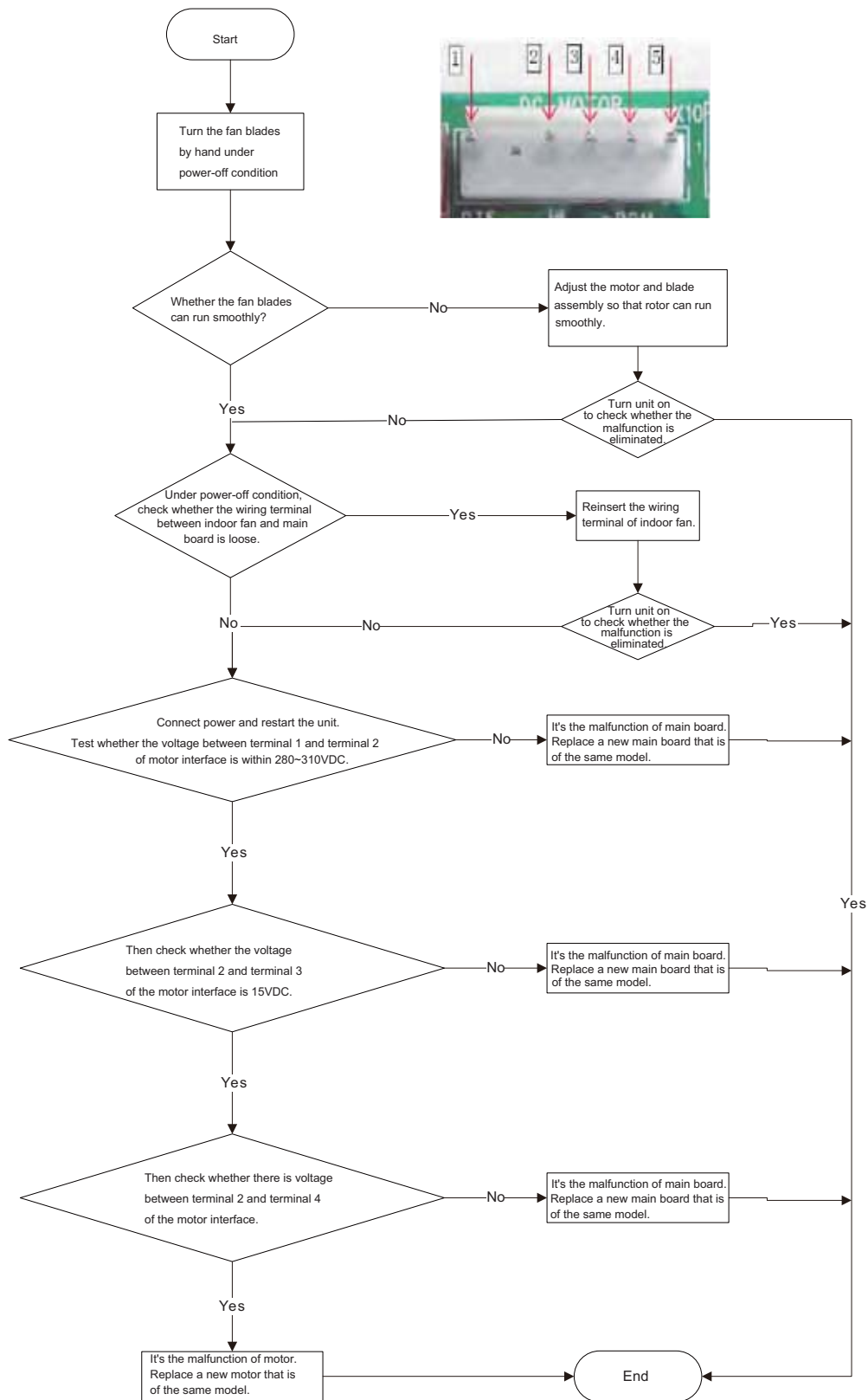

3. Malfunction of Protection of Jumper Cap C5

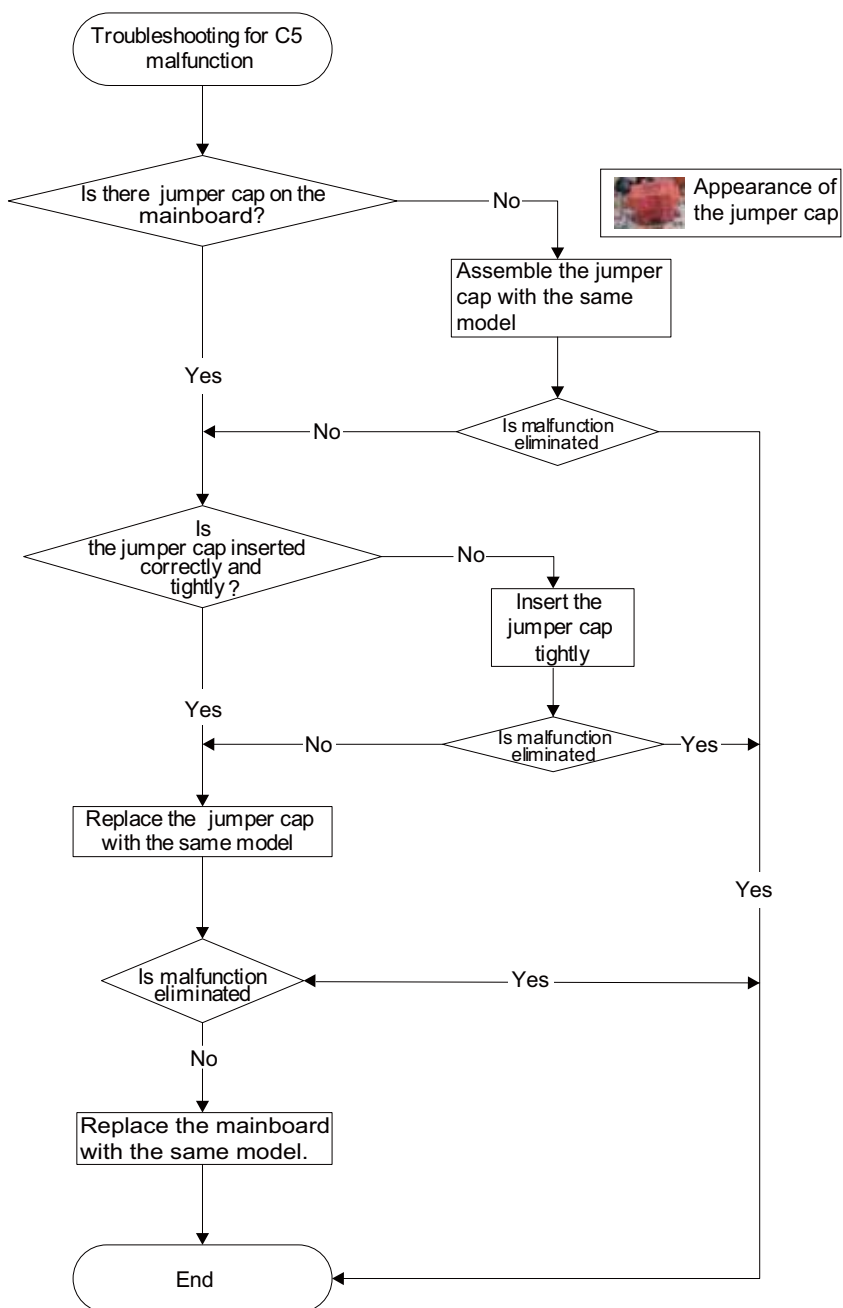

4. Malfunction of Overcurrent Protection E5

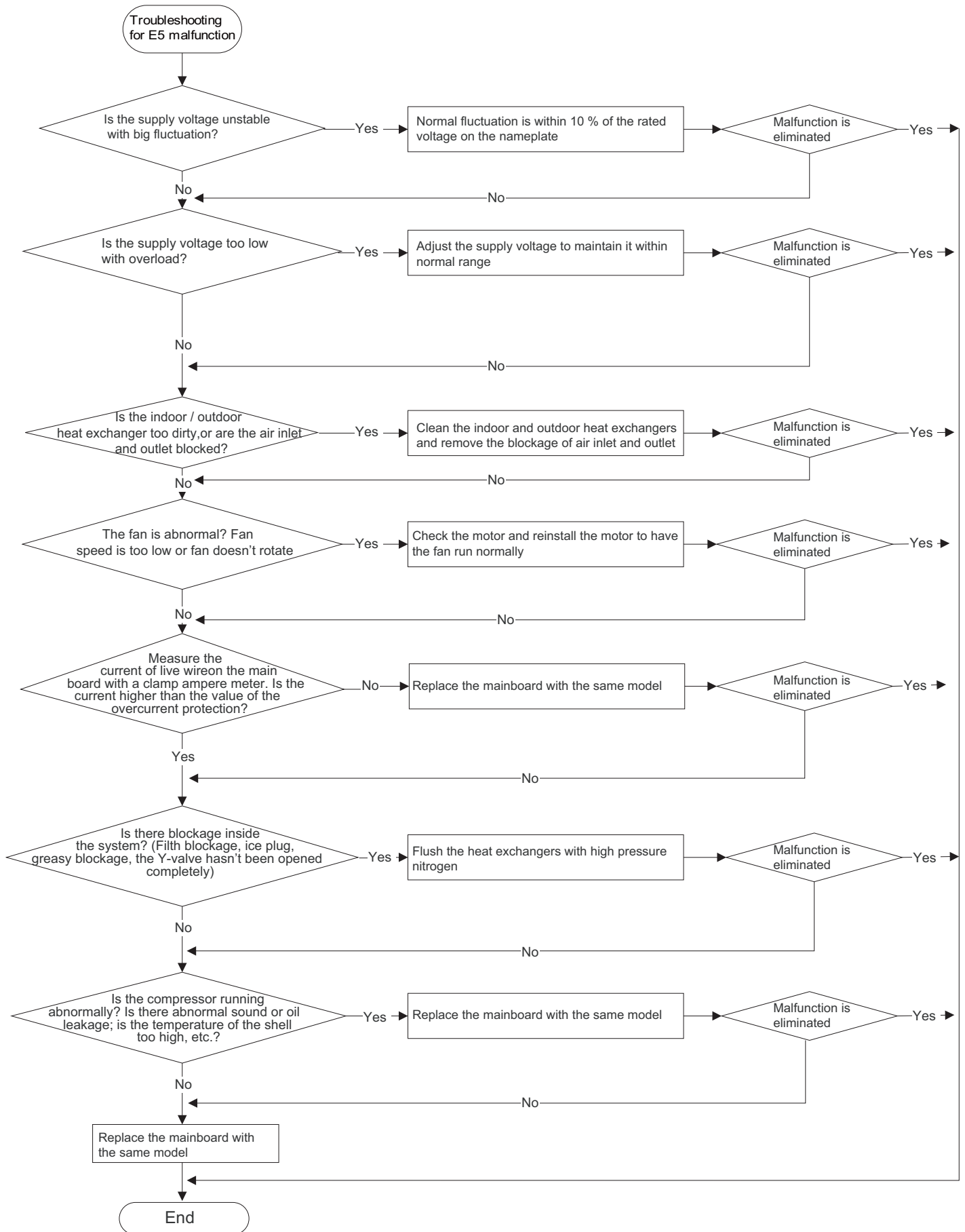

5. Communication Malfunction E6

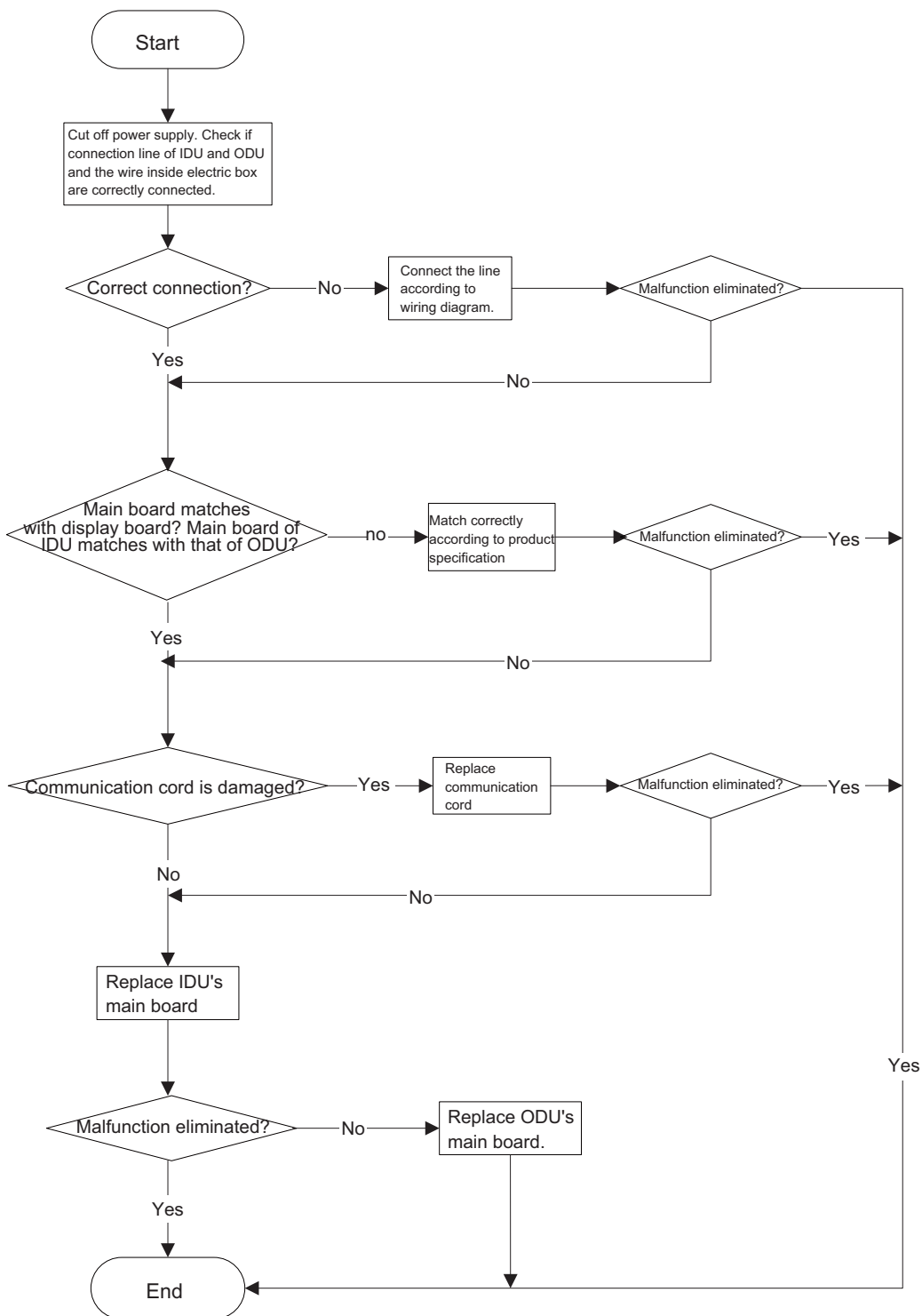

Outdoor Unit

13K

1. Capacity charging malfunction (outdoor unit malfunction) (AP1 below means control board of outdoor unit)

Main detection points:

- Detect if the voltage of L and N terminal of XT wiring board is between 210VAC-240VAC by alternating voltage meter;
- Is reactor (L) well connected? Is connection wire loosened or pulled out? Is reactor (L) damaged?

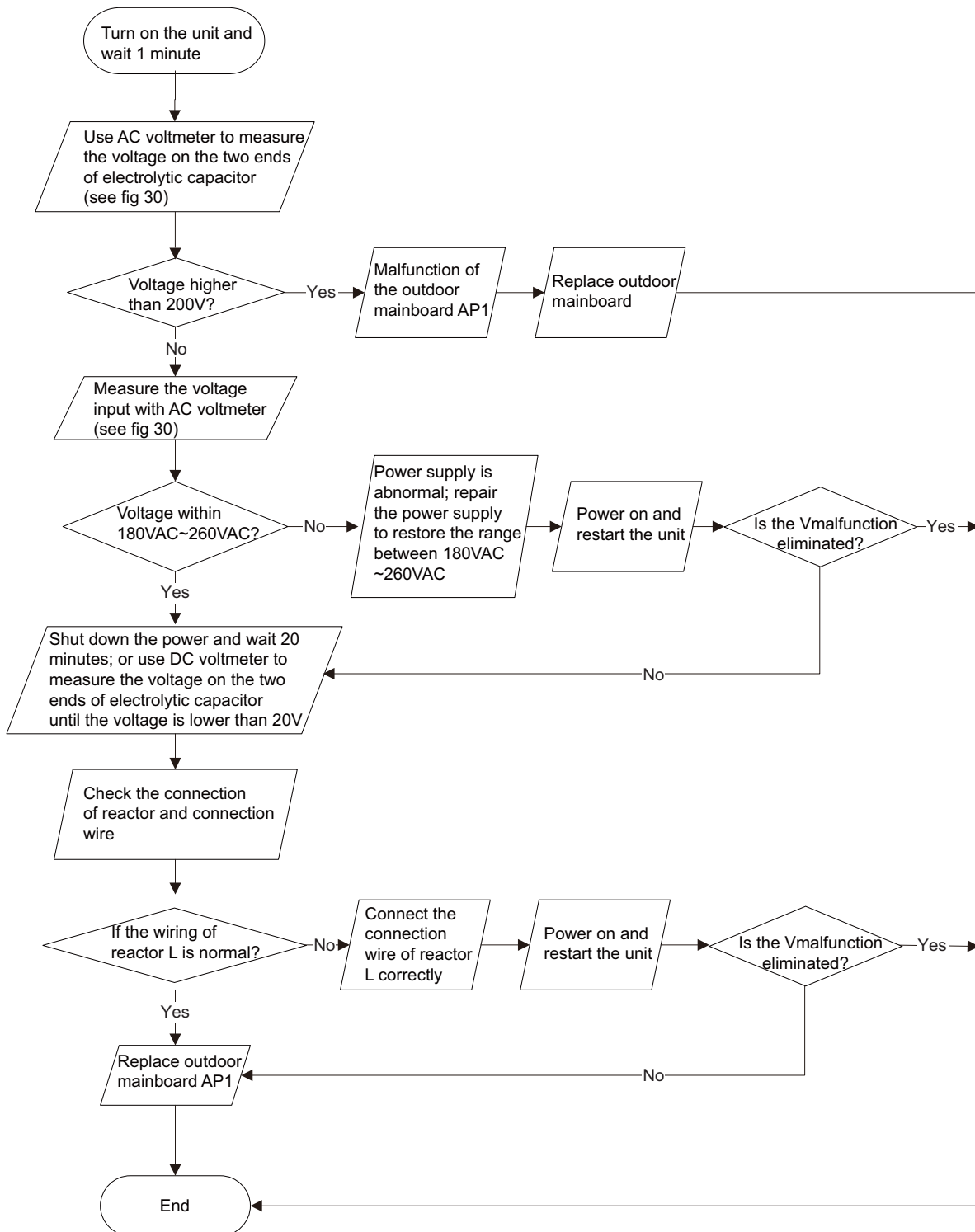

**2. IPM protection(H5), desynchronizing malfunction(H7), overcurrent of compressor phase current (P5) (AP1 below means control board of outdoor unit)**

Main detection points:

- Is voltage input within the normal range
- If the control board AP1 is well connected with compressor COMP? If they are loosened? If the connection sequence is correct?
- Heat exchange of unit is not good (heat exchanger is dirty and unit radiating environment is bad);
- If the system pressure is too high?
- If the refrigerant charging amount is appropriate?
- If coil resistance of compressor is normal? Is compressor coil insulating to copper pipe well?
- If the work load of unit is heavy? If radiating of unit is good?

Malfunction diagnosis process:

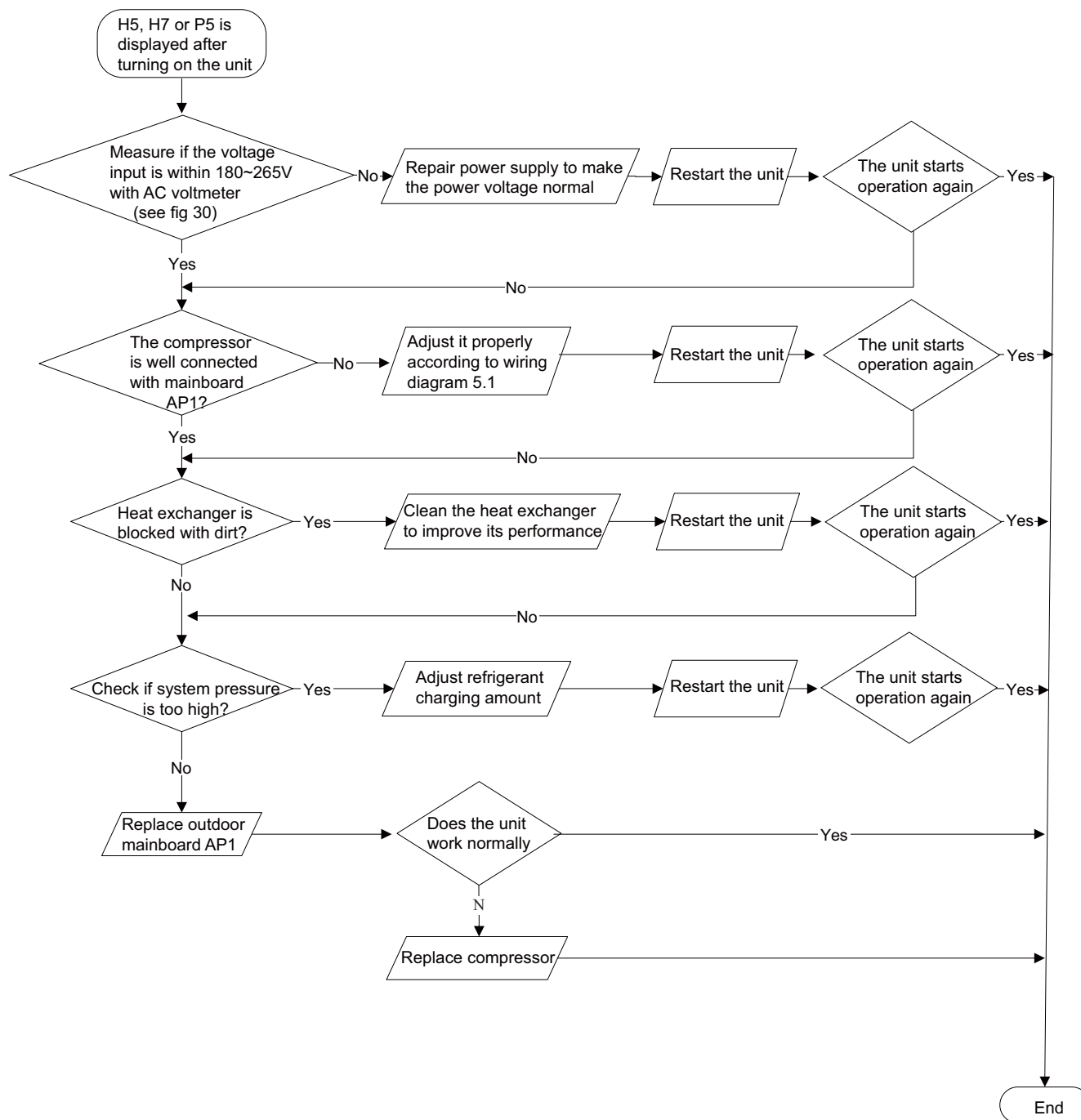

### 3. High temperature and overload protection (E8)(AP1 below means control board of outdoor unit)

Main detection points:

- If the outdoor ambient temperature is in normal range;
- If the indoor and outdoor fan are running normally;
- If the radiating environment of indoor and outdoor unit is good.

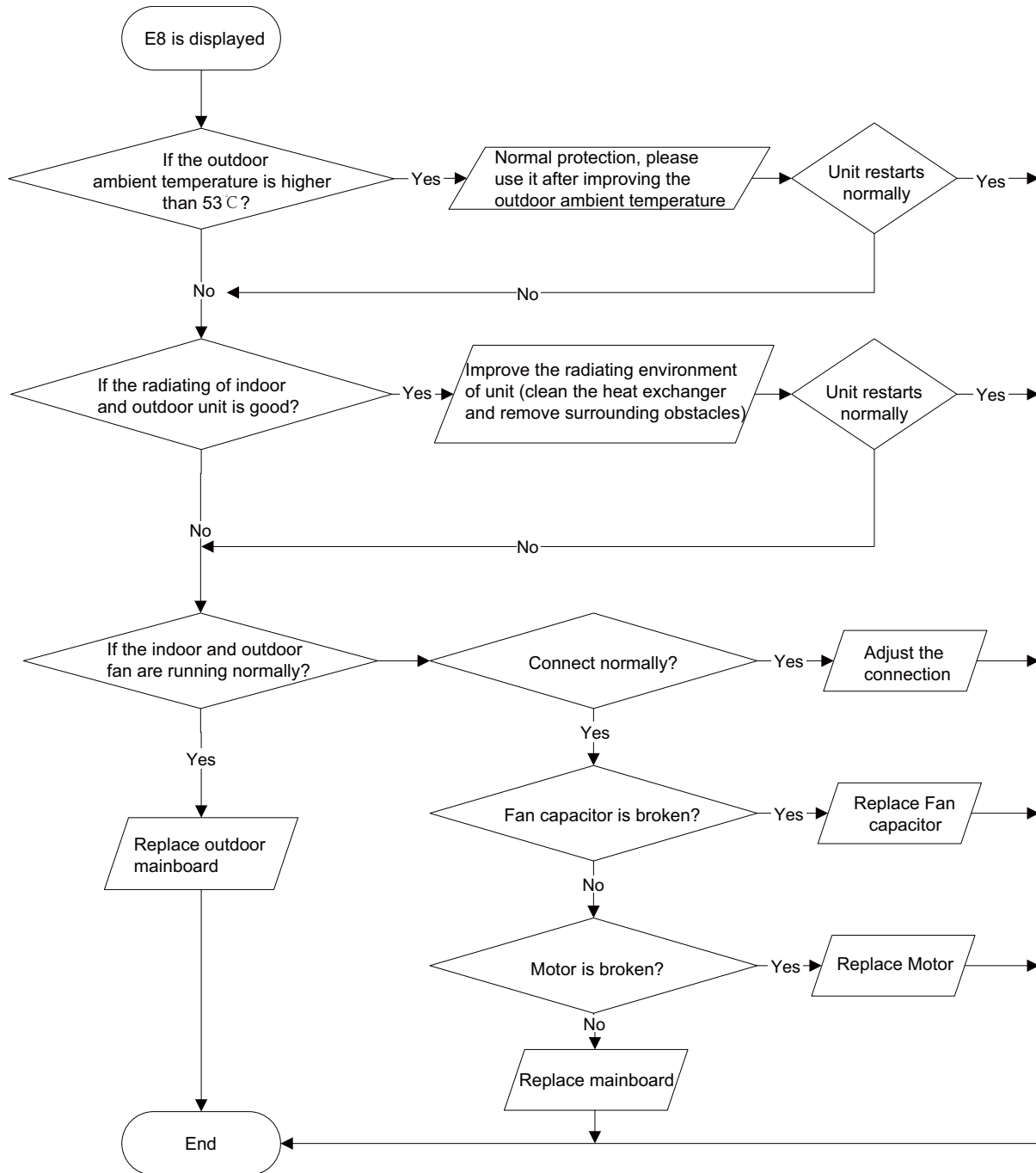

4. Start-up failure (LC) (AP1 below means control board of outdoor unit)

Main detection points:

- If the compressor wiring is correct?
- If the stop time of compressor is sufficient?
- If the compressor is damaged?
- If the refrigerant charging amount is too much?

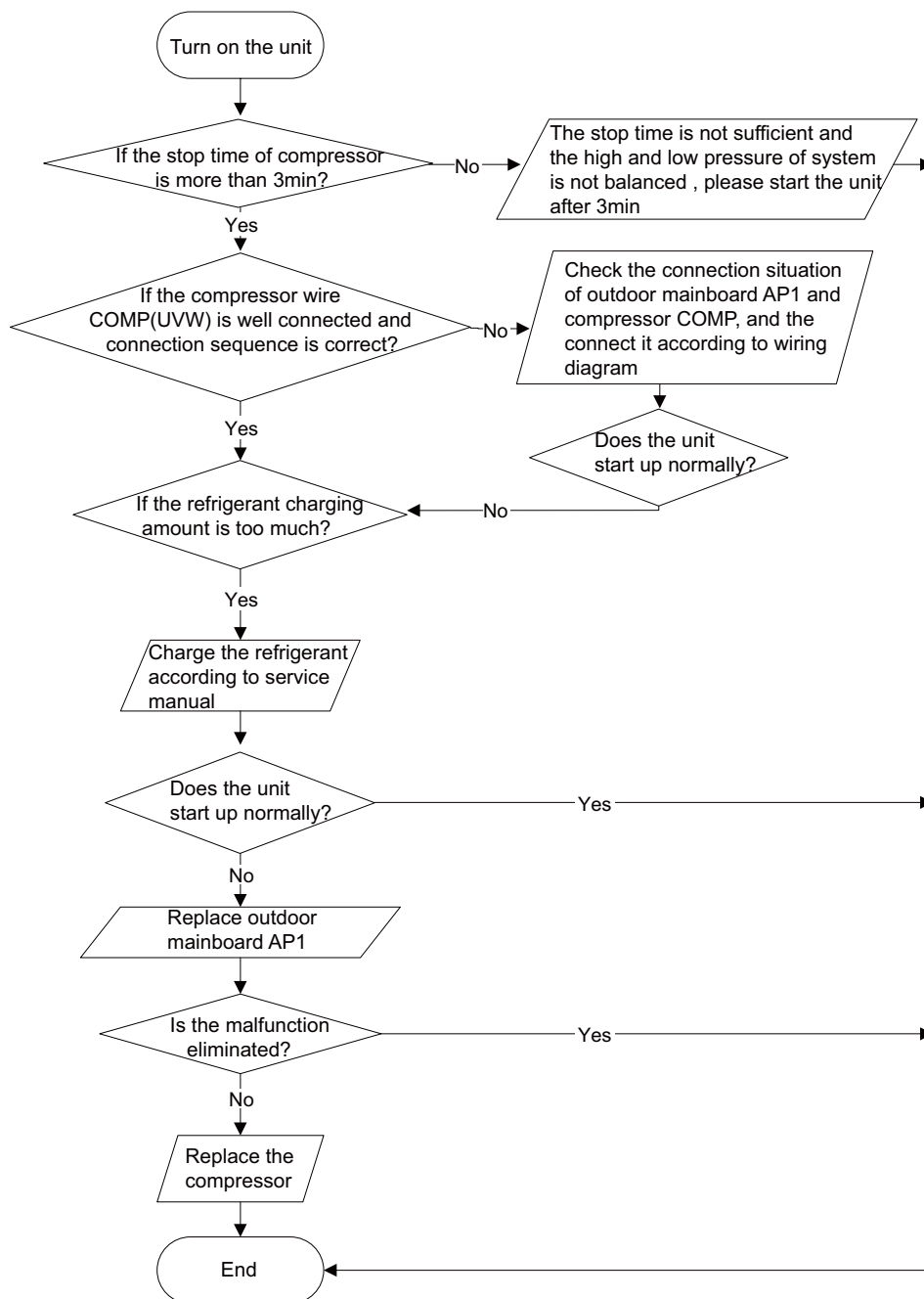

**5. Overload and high discharge temperature malfunction**

**Main detection points:**

- If the electronic expansion valve is connected well? Is the electronic expansion valve damaged?
- If the refrigerant is leaked?
- The compressor overload protection terminal is not connected well with the mainboard?
- If the overload protector is damaged?
- Heat exchange of unit is not good? (heat exchanger is dirty and unit radiating environment is bad)
- Too much load of the system causes high temperature of compressor after working for a long time?
- Malfunction of discharge temperature sensor?

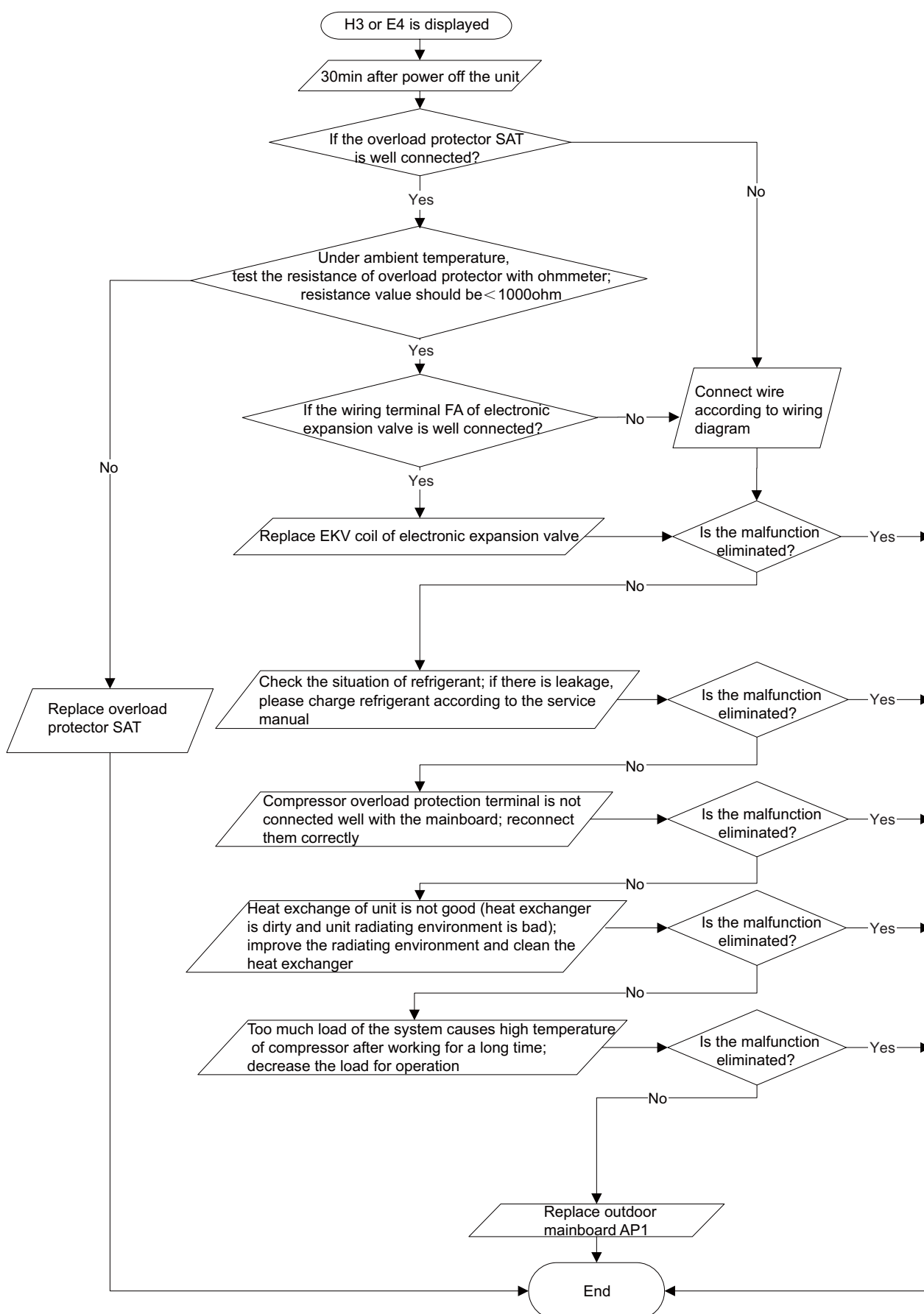

**6. PFC (correction for power factor) malfunction (outdoor unit malfunction)**

**Main detection points:**

- Check if power plug is connected well with the socket
- Check if the reactor of outdoor unit is damaged?

Malfunction diagnosis process:

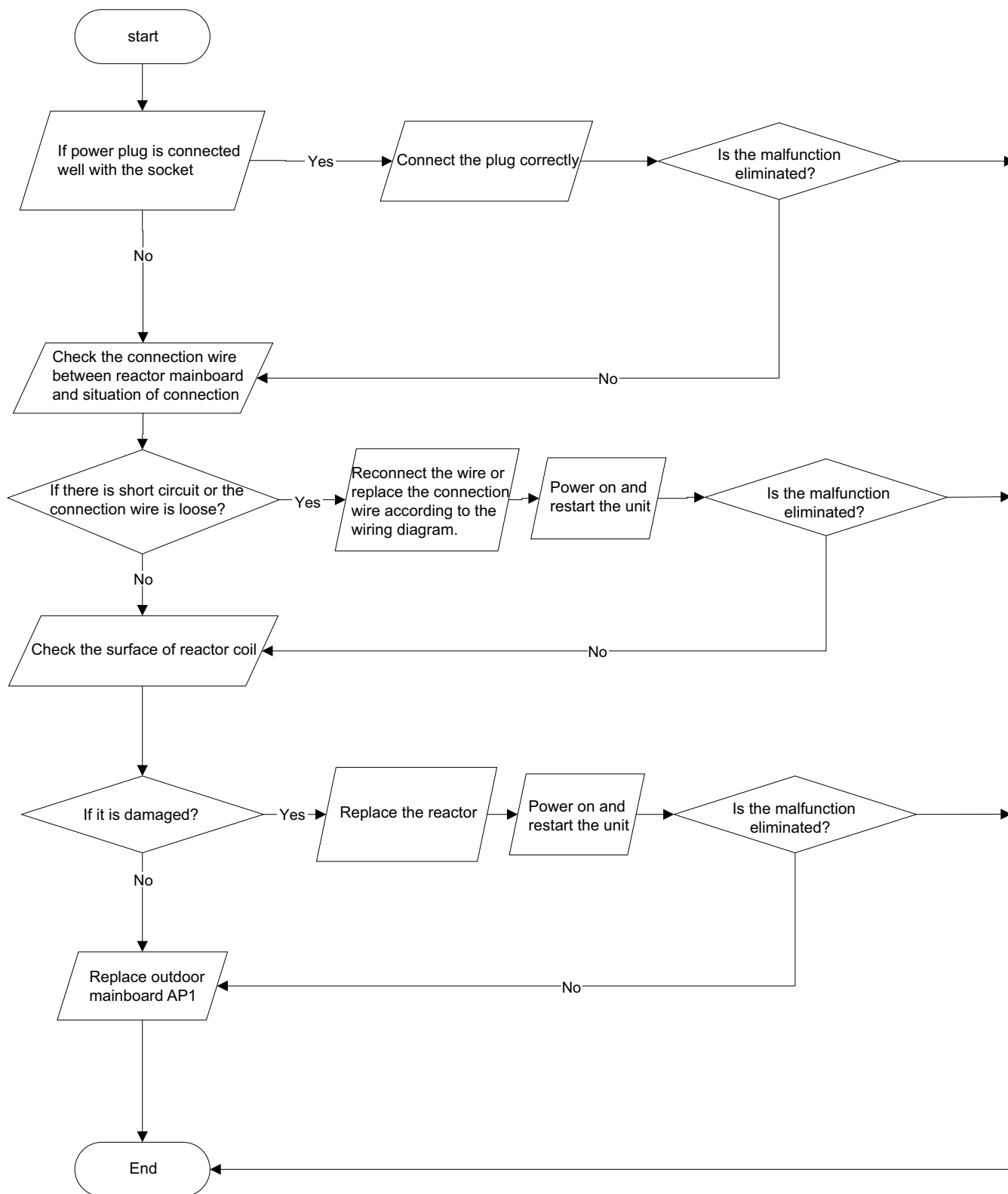

### 7. Communication malfunction (E6)

#### Main detection points:

- Check if the connection wire and the built-in wiring of indoor and outdoor unit are connected well and without damage;
  - If the communication circuit of indoor mainboard is damaged? If the communication circuit of outdoor mainboard (AP1) is damaged?
- Malfunction diagnosis process:

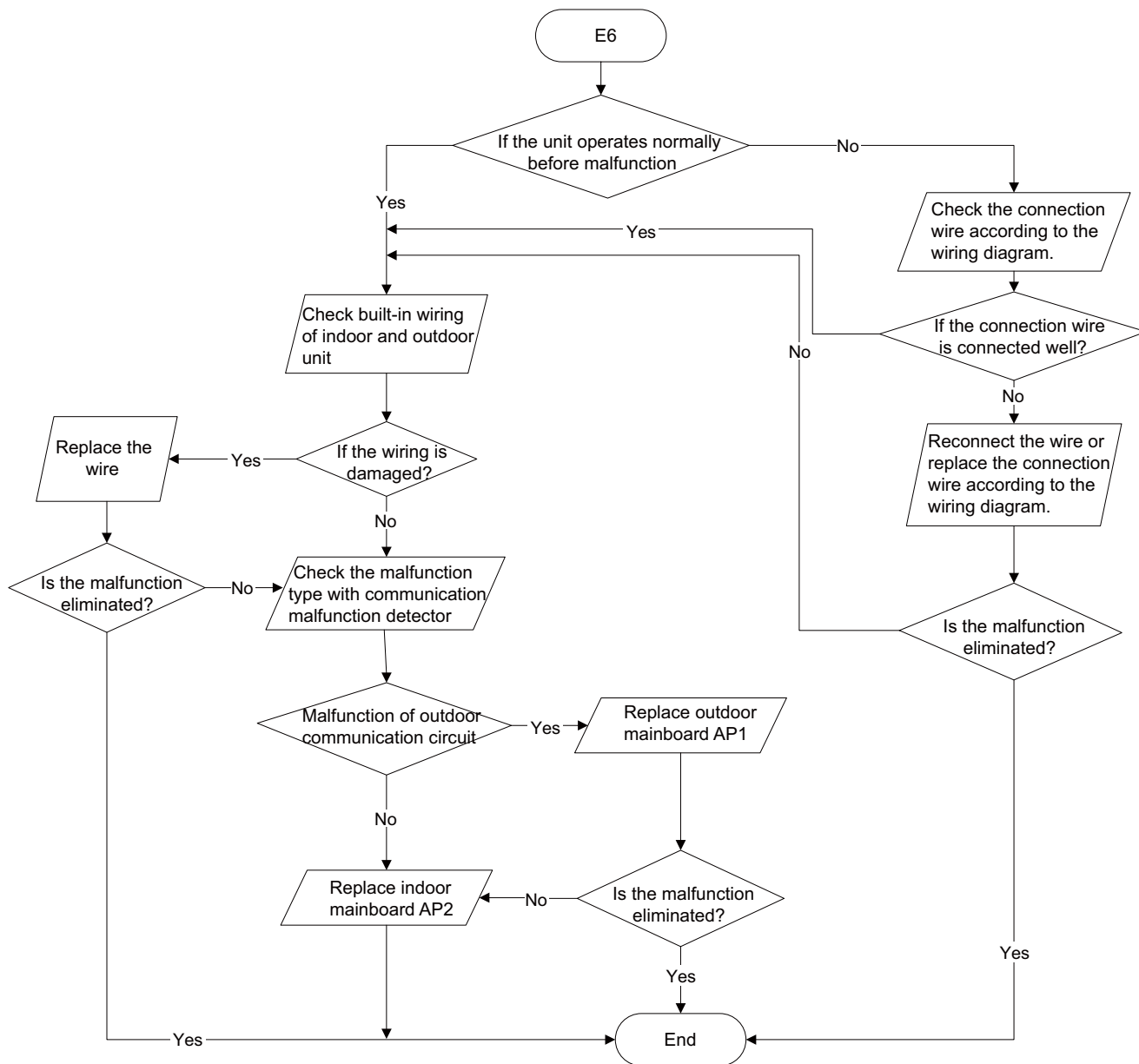

18K

1. Key detection point

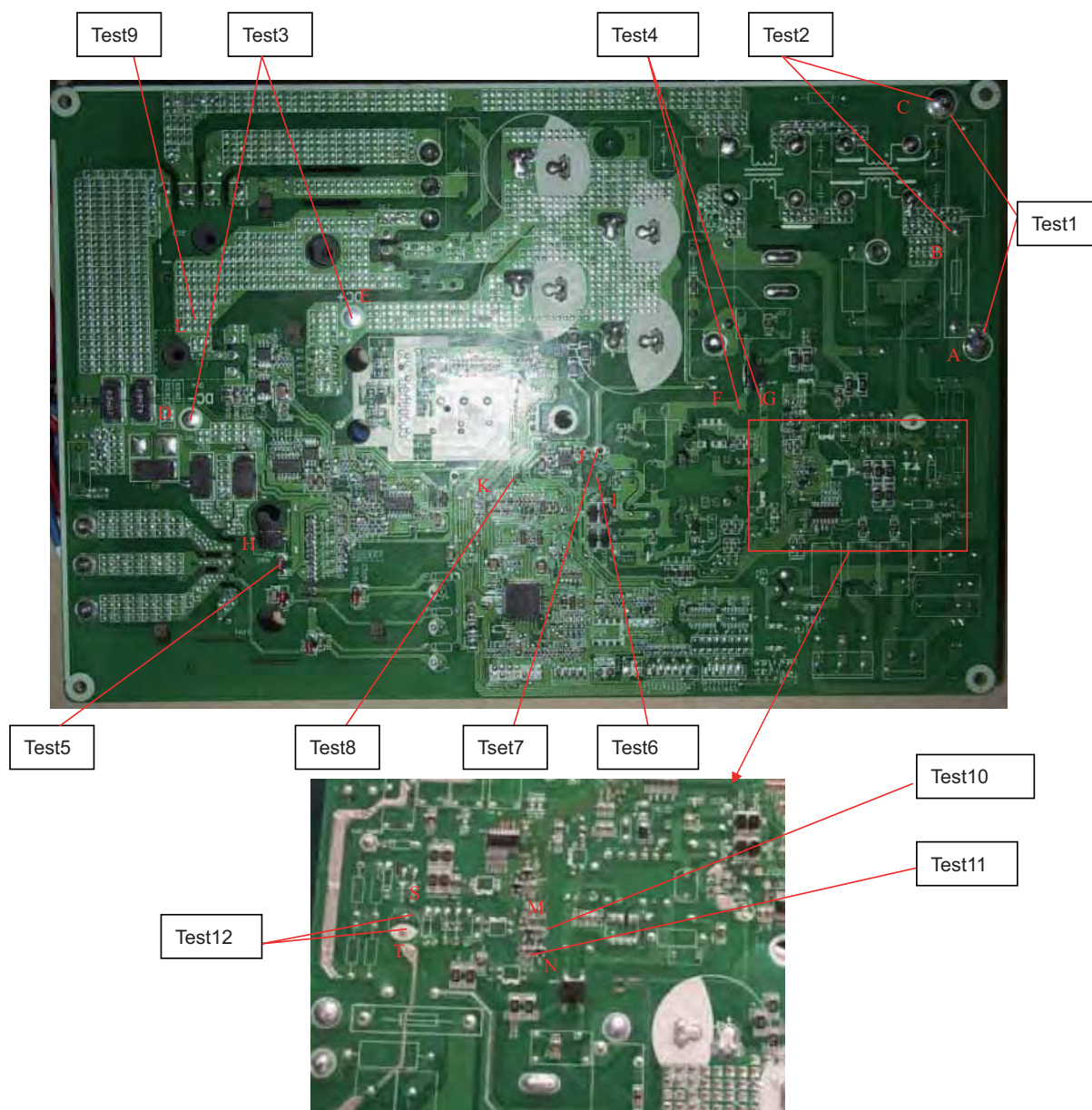

| Test NO | Test point                              | Corresponding component                                  | Test value under normal condition |
|---------|-----------------------------------------|----------------------------------------------------------|-----------------------------------|
| Test 1  | Between A and C                         | Neutral and live wires                                   | 160V~265V                         |
| Test 2  | Between B and C                         | Neutral and live wires                                   | 160V~265V                         |
| Test 3  | Between D and E                         | DC busbar electrolytic capacitor                         | DC 180V~380V                      |
| Test 4  | Between F and G                         | Electrolytic capacitor of power                          | DC 180V~380V                      |
| Test 5  | Two ends of diode D15                   | D15(IPM modular +15V power supply)                       | DC 14.5V~15.6V                    |
| Test 6  | Two ends of electrolytic capacitor C715 | C715(+12V power supply)                                  | DC 12V~13V                        |
| Test 7  | Two ends of electrolytic capacitor C710 | C710(+5V power supply)                                   | DC 5V                             |
| Test 8  | Two ends of electrolytic capacitor C226 | C226(+3.3V power supply)                                 | DC 3.3V                           |
| Test 9  | Two ends of chip capacitor C912         | C912(+17V power supply)                                  | DC 15V~18V                        |
| Test 10 | Between M to GND                        | Point M of R75 to ground (signal sending port of ODU)    | Fluctuate between 0~3.3V          |
| Test 11 | Between N to GND                        | Point N of R123 to ground (signal receiving port of ODU) | Fluctuate between 0~3.3V          |
| Test 12 | Between S and T                         | Power supply of communication ring                       | DC 56V                            |

## 2. Capacity charging malfunction (outdoor unit malfunction) (AP1 below is control board of outdoor unit)

Main detection point:

- Detect if the voltage of L and N terminal of wiring board is between 210AC-240AC by alternating voltage meter;
- Is reactor (L) well connected? Is connection wire loosened or pull-out? Is reactor (L) damaged?

Malfunction diagnosis process:

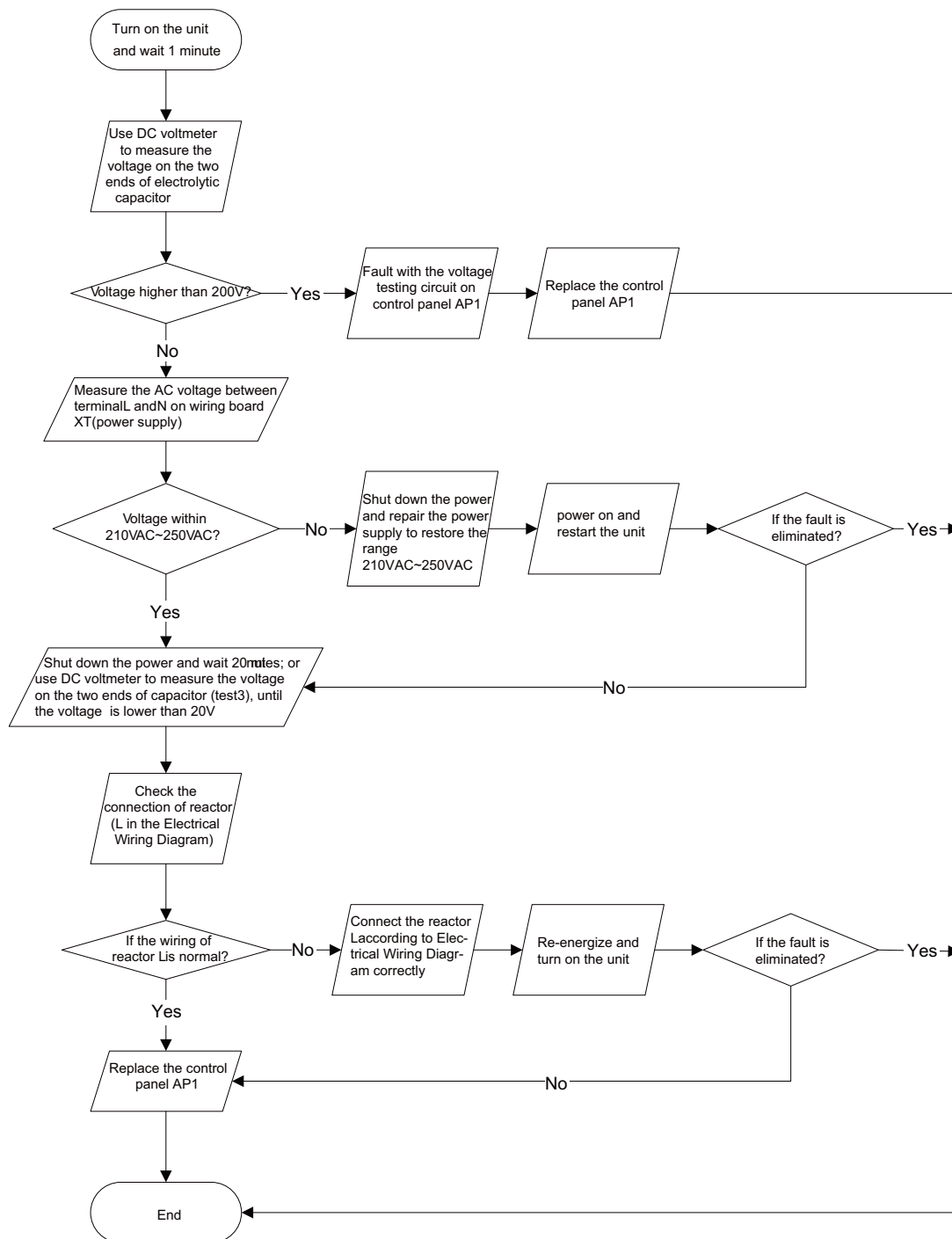

**3. IPM protection, desynchronizing malfunction, phase current of compressor is overcurrent (AP1 below is control board of outdoor unit)**

Main detection point:

- If control board AP1 and compressor COMP is well connected? If they are loosened? If the connection sequence is correct?
- Is voltage input in the normal range (Test the voltage between L, N of wiring board XT by DC voltage meter)?
- If coil resistance of compressor is normal? Is compressor coil insulating to copper pipe well?
- If the work load of unit is heavy? If radiating of unit is well?
- If the refrigerant charging is appropriate?

Malfunction diagnosis process:

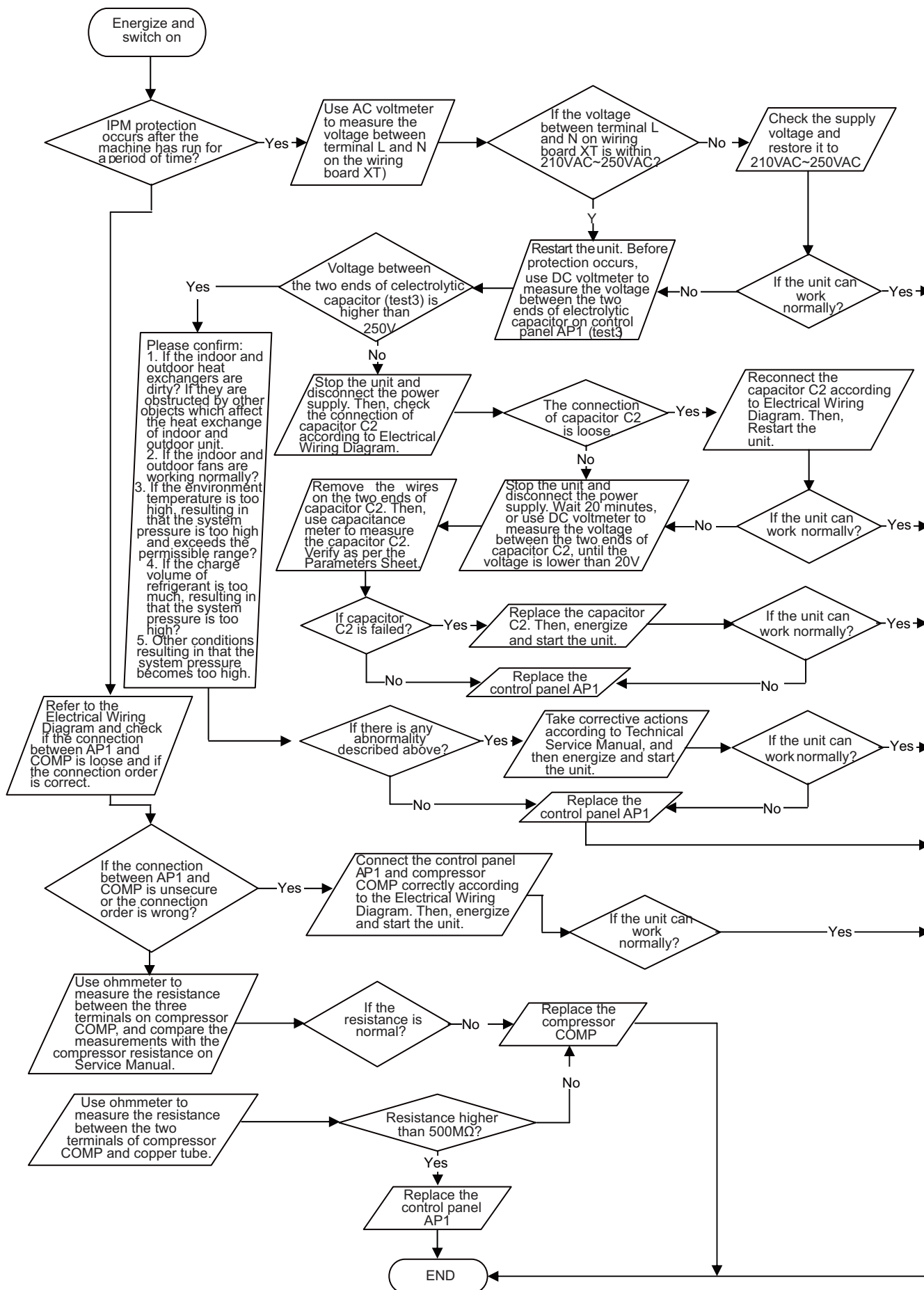

4. Diagnosis for anti-high temperature, overload protection (AP1 below is control board of outdoor unit)

Main detection point:

- If the outdoor ambient temperature is in normal range;
- If the indoor and outdoor fan is running normal;
- If the radiating environment of indoor and outdoor unit is well.

Malfunction diagnosis process:

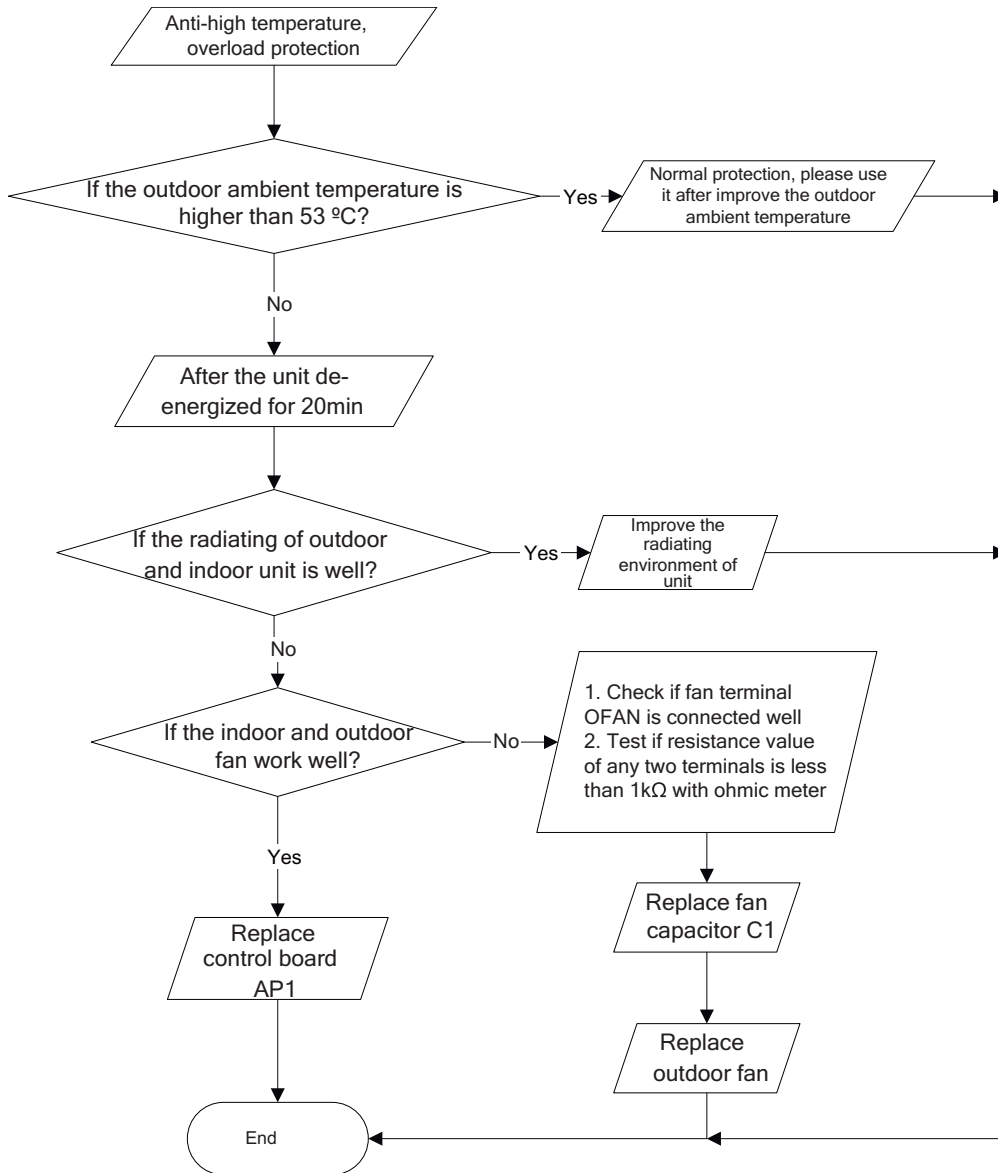

## 5. Diagnosis for failure start up malfunction (AP1 below is control board of outdoor unit)

Main detection point:

- If the compressor wiring is correct?
- If the stop time of compressor is enough?
- If the compressor is damaged?
- If the refrigerant charging is too much?

Malfunction diagnosis process:

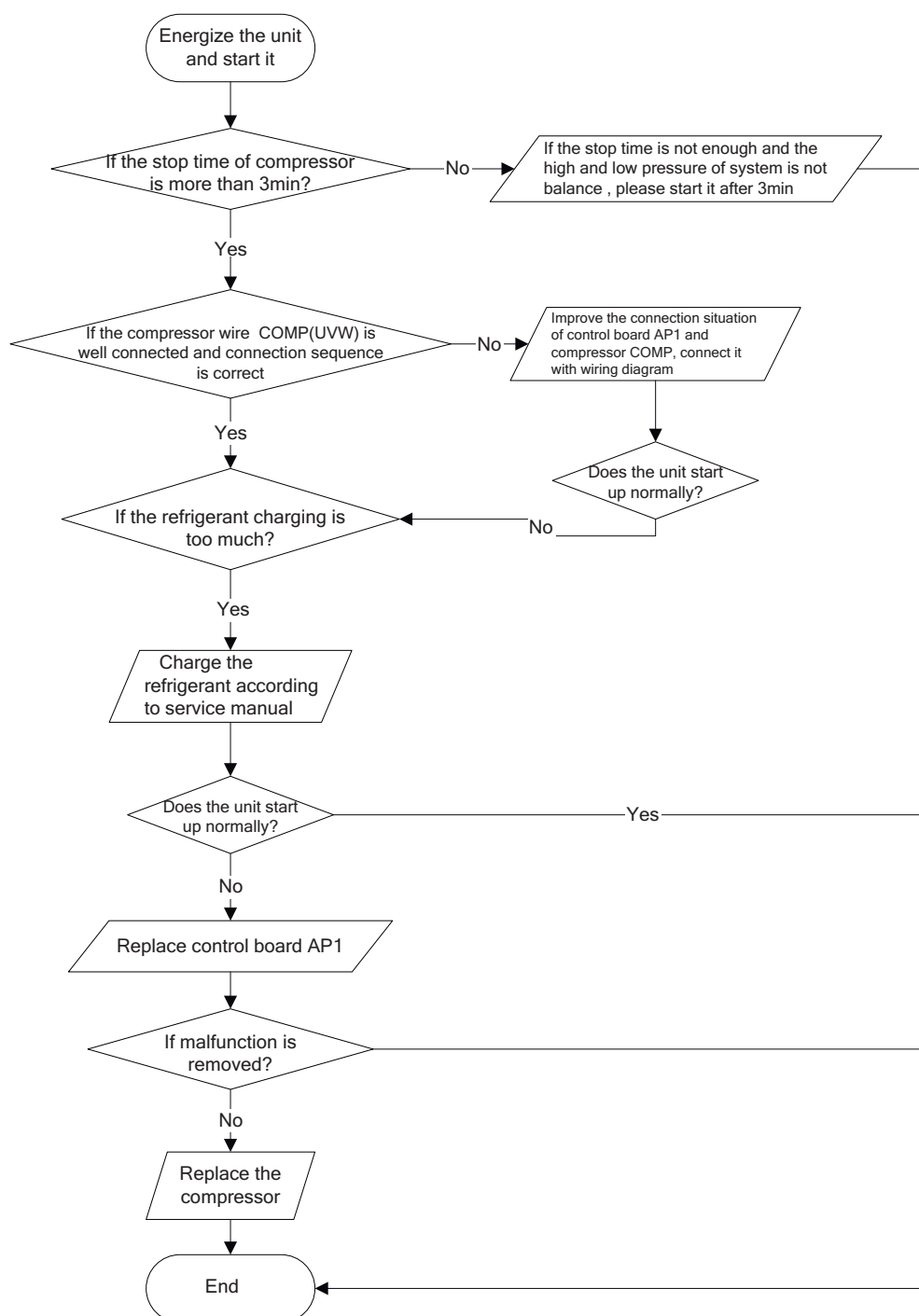

### 6. Diagnosis for compressor synchronism (AP1 below is control board of outdoor unit)

Main detection point:

- If the system pressure is over-high?
- If the work voltage is over-low?

Malfunction diagnosis process:

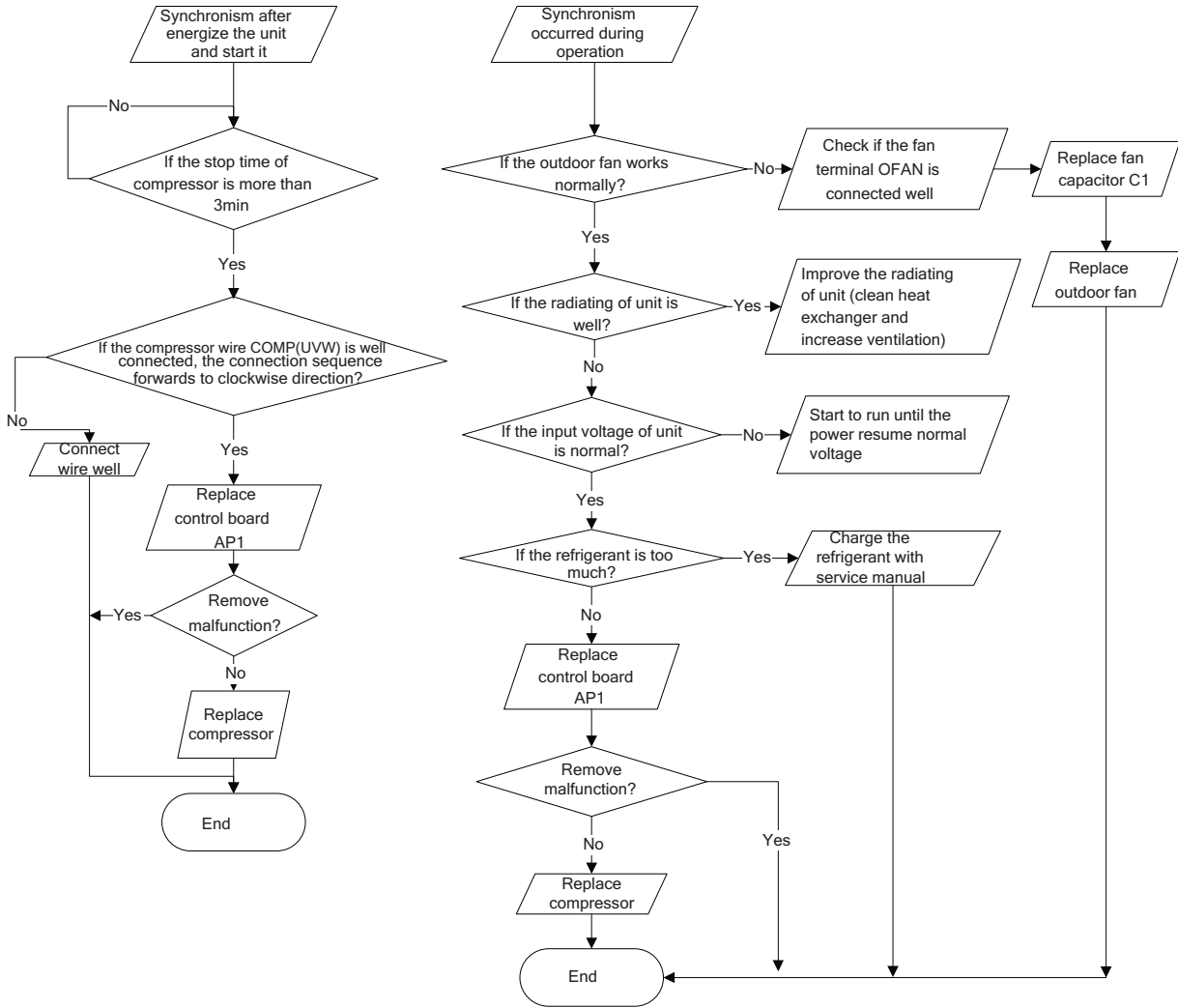

### 7. Diagnosis for overload and discharge malfunction (AP1 below is control board of outdoor unit)

Main detection point:

- If the electron expansion valve is connected well? Is the expansion valve damaged?
- If the refrigerant is leakage?
- If the overload protector is damaged?

Malfunction diagnosis process:

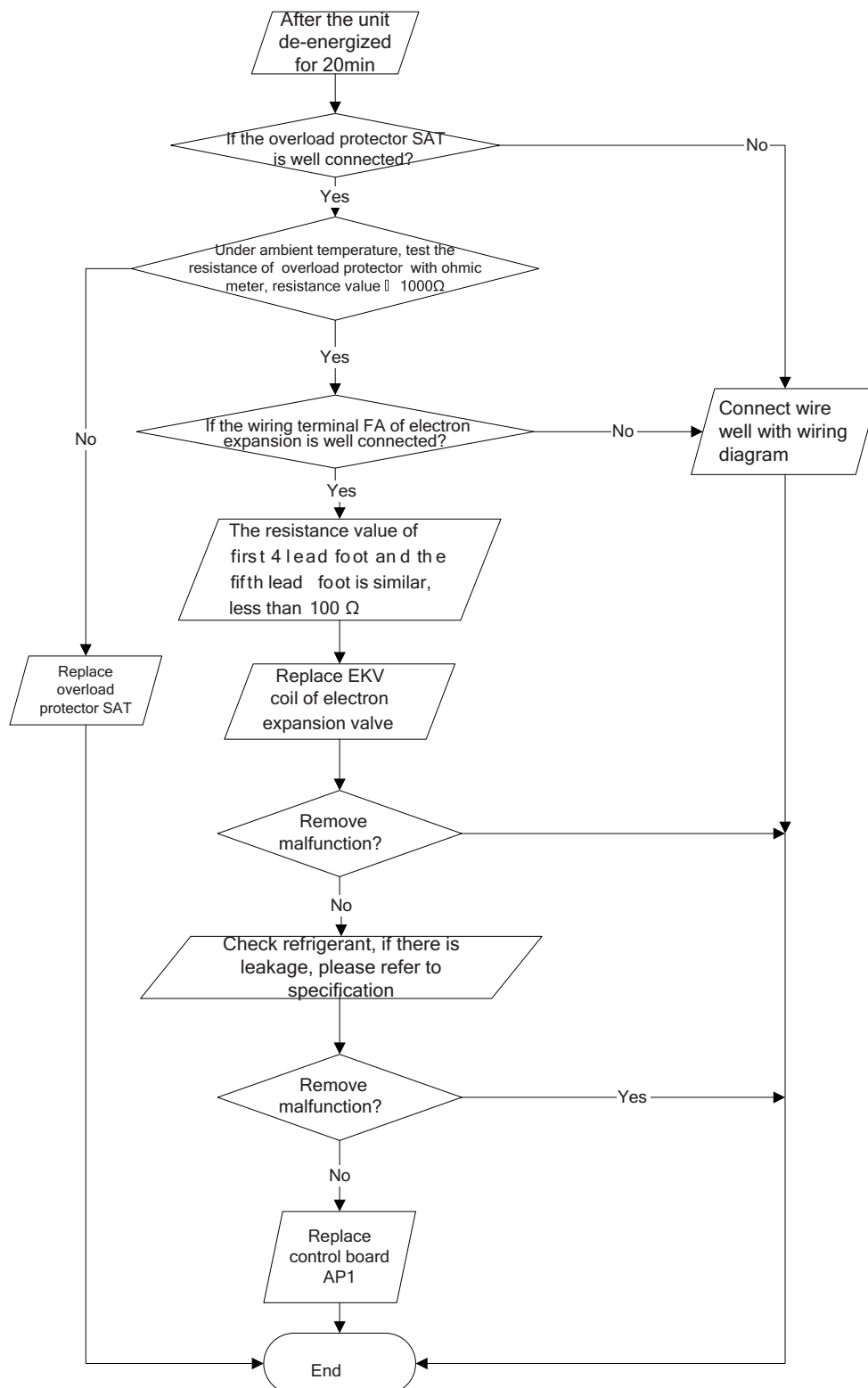

8. PFC (correction for power factor) malfunction (outdoor unit malfunction) (AP1 below is control board of outdoor unit)

Main detection point:

- Check if reactor (L) of outdoor unit and PFC capacity are damaged.

Malfunction diagnosis process:

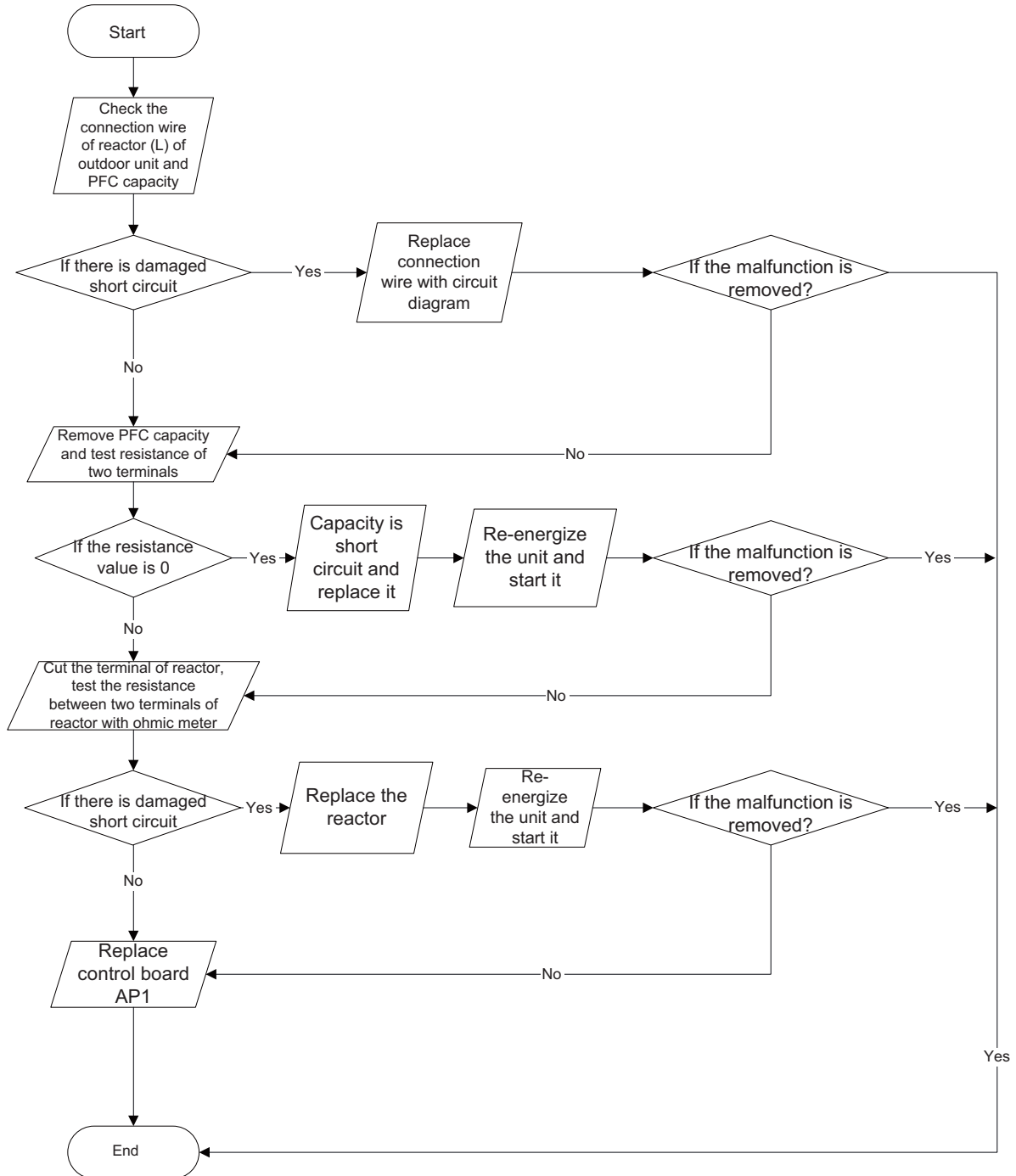

### 9. Communication malfunction (AP1 below is control board of outdoor unit)

Main detection point:

- Check if the connection wire and the built-in wiring of indoor and outdoor unit is connected well and no damaged;
- If the communication circuit of indoor mainboard is damaged? If the communication circuit of outdoor mainboard (AP1) is damaged

Malfunction diagnosis process:

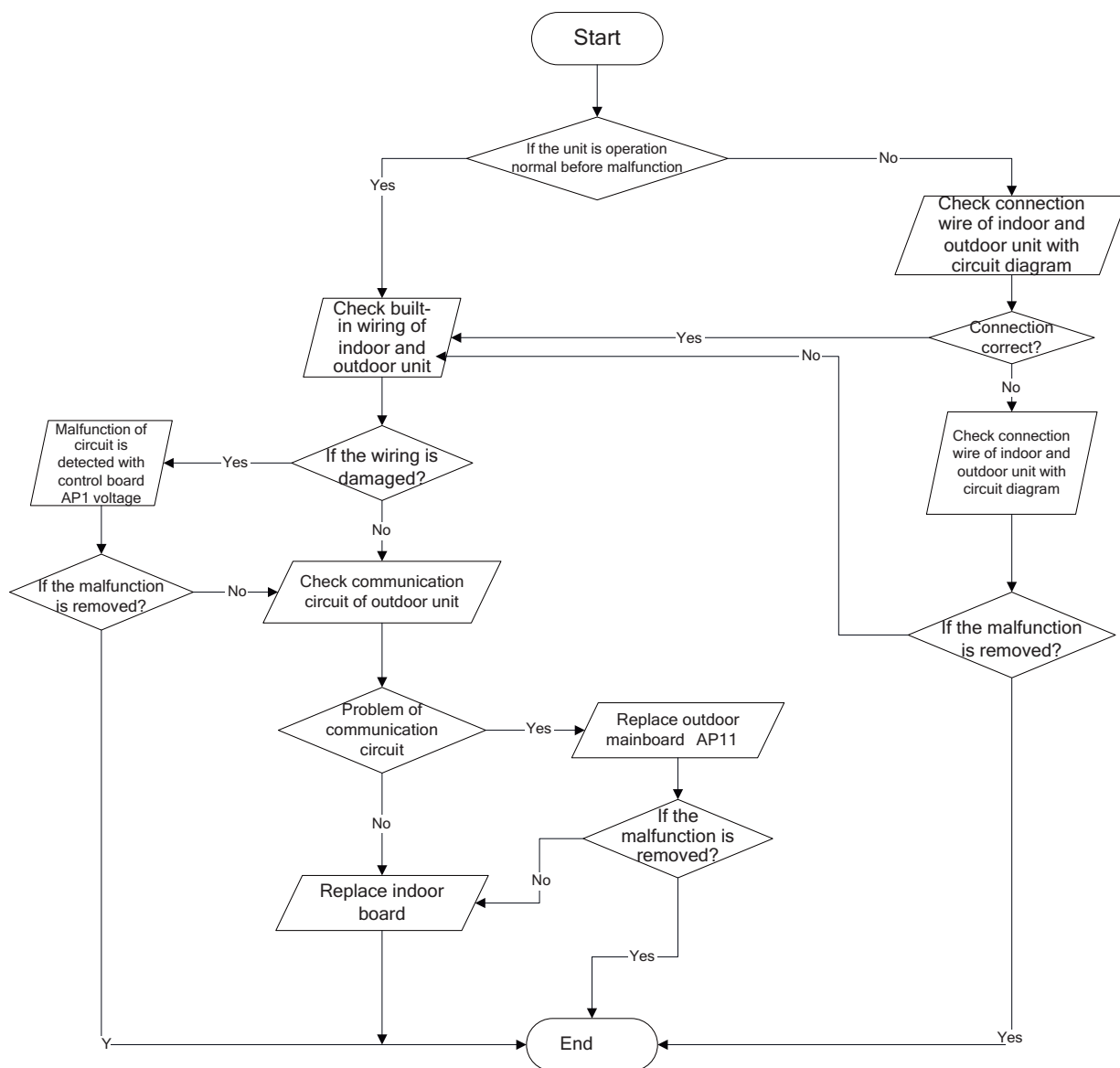

10. Diagnosis process for outdoor communication circuit

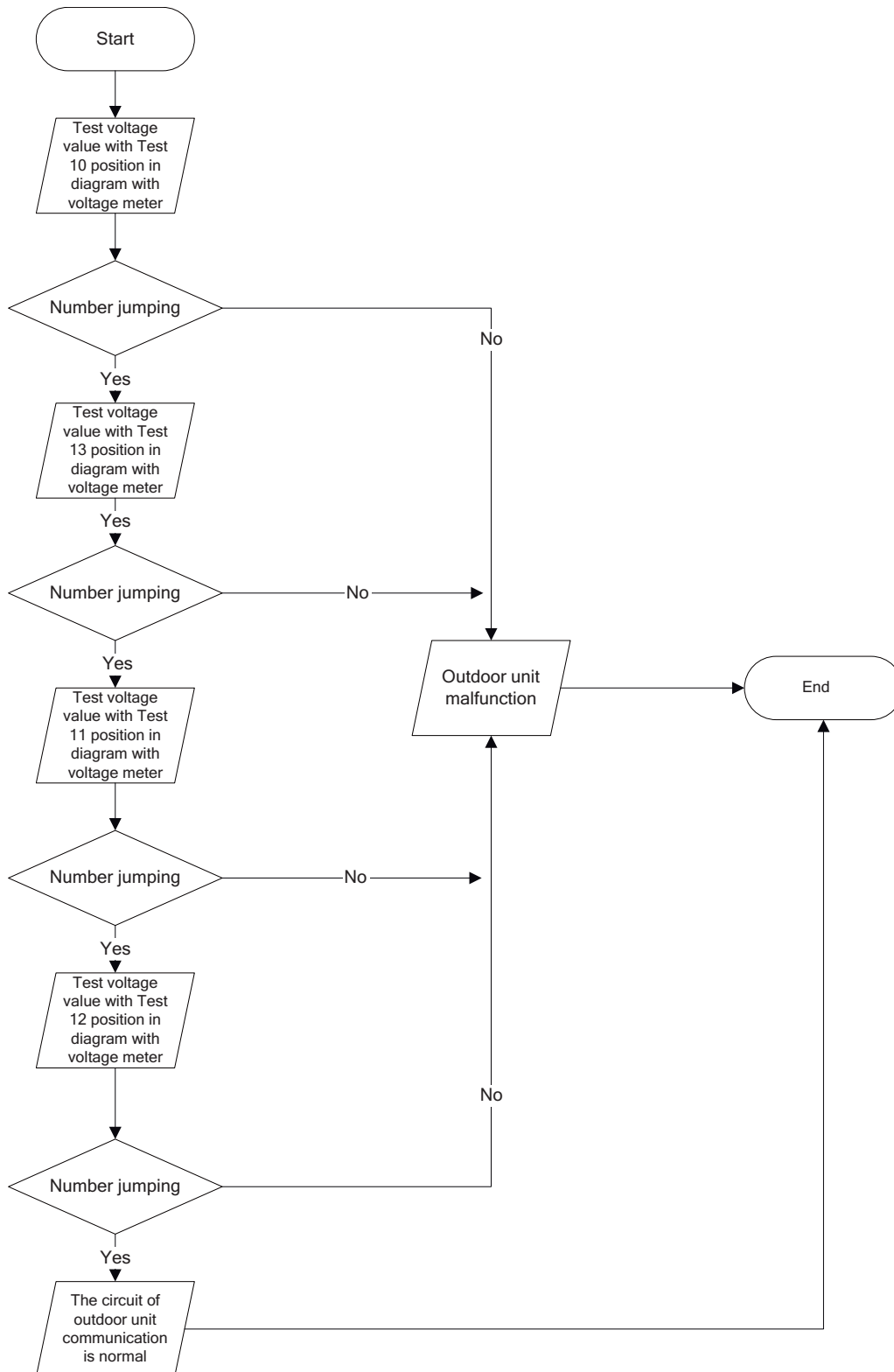

## 9.3 Troubleshooting for Normal Malfunction

### 1. Air Conditioner Can't be Started Up

| Possible Causes                                                                                     | Discriminating Method (Air conditioner Status)                                                                      | Troubleshooting                                                                                                                                                                                                                                        |
|-----------------------------------------------------------------------------------------------------|---------------------------------------------------------------------------------------------------------------------|--------------------------------------------------------------------------------------------------------------------------------------------------------------------------------------------------------------------------------------------------------|
| No power supply, or poor connection for power plug                                                  | After energization, operation indicator isn't bright and the buzzer can't give out sound                            | Confirm whether it's due to power failure. If yes, wait for power recovery. If not, check power supply circuit and make sure the power plug is connected well.                                                                                         |
| Wrong wire connection between indoor unit and outdoor unit, or poor connection for wiring terminals | Under normal power supply circumstances, operation indicator isn't bright after energization                        | Check the circuit according to circuit diagram and connect wires correctly. Make sure all wiring terminals are connected firmly                                                                                                                        |
| Electric leakage for air conditioner                                                                | After energization, room circuit breaker trips off at once                                                          | Make sure the air conditioner is grounded reliably<br>Make sure wires of air conditioner is connected correctly<br>Check the wiring inside air conditioner. Check whether the insulation layer of power cord is damaged; if yes, place the power cord. |
| Model selection for air switch is improper                                                          | After energization, air switch trips off                                                                            | Select proper air switch                                                                                                                                                                                                                               |
| Malfunction of remote controller                                                                    | After energization, operation indicator is bright, while no display on remote controller or buttons have no action. | Replace batteries for remote controller<br>Repair or replace remote controller                                                                                                                                                                         |

### 2. Poor Cooling (Heating) for Air Conditioner

| Possible Causes                                                    | Discriminating Method (Air conditioner Status)                                                                                                                                                                                                                                                                | Troubleshooting                                                                           |
|--------------------------------------------------------------------|---------------------------------------------------------------------------------------------------------------------------------------------------------------------------------------------------------------------------------------------------------------------------------------------------------------|-------------------------------------------------------------------------------------------|
| Set temperature is improper                                        | Observe the set temperature on remote controller                                                                                                                                                                                                                                                              | Adjust the set temperature                                                                |
| Rotation speed of the IDU fan motor is set too low                 | Small wind blow                                                                                                                                                                                                                                                                                               | Set the fan speed at high or medium                                                       |
| Filter of indoor unit is blocked                                   | Check the filter to see it's blocked                                                                                                                                                                                                                                                                          | Clean the filter                                                                          |
| Installation position for indoor unit and outdoor unit is improper | Check whether the installation position is proper according to installation requirement for air conditioner                                                                                                                                                                                                   | Adjust the installation position, and install the rainproof and sunproof for outdoor unit |
| Refrigerant is leaking                                             | Discharged air temperature during cooling is higher than normal discharged wind temperature;<br>Discharged air temperature during heating is lower than normal discharged wind temperature;<br>Unit's pressure is much lower than regulated range                                                             | Find out the leakage causes and deal with it.<br>Add refrigerant.                         |
| Malfunction of 4-way valve                                         | Blow cold wind during heating                                                                                                                                                                                                                                                                                 | Replace the 4-way valve                                                                   |
| Malfunction of capillary                                           | Discharged air temperature during cooling is higher than normal discharged wind temperature;<br>Discharged air temperature during heating is lower than normal discharged wind temperature;<br>Unit's pressure is much lower than regulated range. If refrigerant isn't leaking, part of capillary is blocked | Replace the capillary                                                                     |
| Flow volume of valve is insufficient                               | The pressure of valves is much lower than that stated in the specification                                                                                                                                                                                                                                    | Open the valve completely                                                                 |
| Malfunction of horizontal louver                                   | Horizontal louver can't swing                                                                                                                                                                                                                                                                                 | Refer to point 3 of maintenance method for details                                        |
| Malfunction of the IDU fan motor                                   | The IDU fan motor can't operate                                                                                                                                                                                                                                                                               | Refer to troubleshooting for H6 for maintenance method in details                         |
| Malfunction of the ODU fan motor                                   | The ODU fan motor can't operate                                                                                                                                                                                                                                                                               | Refer to point 4 of maintenance method for details                                        |
| Malfunction of compressor                                          | Compressor can't operate                                                                                                                                                                                                                                                                                      | Refer to point 5 of maintenance method for details                                        |

### 3. Horizontal Louver Can't Swing

| Possible Causes                           | Discriminating Method (Air conditioner Status)               | Troubleshooting                                                                                  |
|-------------------------------------------|--------------------------------------------------------------|--------------------------------------------------------------------------------------------------|
| Wrong wire connection, or poor connection | Check the wiring status according to circuit diagram         | Connect wires according to wiring diagram to make sure all wiring terminals are connected firmly |
| Stepping motor is damaged                 | Stepping motor can't operate                                 | Repair or replace stepping motor                                                                 |
| Main board is damaged                     | Others are all normal, while horizontal louver can't operate | Replace the main board with the same model                                                       |

#### 4. ODU Fan Motor Can't Operate

| Possible causes                           | Discriminating method (air conditioner status)                                                                                                                      | Troubleshooting                                                                                  |
|-------------------------------------------|---------------------------------------------------------------------------------------------------------------------------------------------------------------------|--------------------------------------------------------------------------------------------------|
| Wrong wire connection, or poor connection | Check the wiring status according to circuit diagram                                                                                                                | Connect wires according to wiring diagram to make sure all wiring terminals are connected firmly |
| Capacity of the ODU fan motor is damaged  | Measure the capacity of fan capacitor with an universal meter and find that the capacity is out of the deviation range indicated on the nameplate of fan capacitor. | Replace the capacity of fan                                                                      |
| Power voltage is a little low or high     | Use universal meter to measure the power supply voltage. The voltage is a little high or low                                                                        | Suggest to equip with voltage regulator                                                          |
| Motor of outdoor unit is damaged          | When unit is on, cooling/heating performance is bad and ODU compressor generates a lot of noise and heat.                                                           | Change compressor oil and refrigerant. If no better, replace the compressor with a new one       |

#### 5. Compressor Can't Operate

| Possible causes                           | Discriminating method (air conditioner status)                                                                                                                      | Troubleshooting                                                                                  |
|-------------------------------------------|---------------------------------------------------------------------------------------------------------------------------------------------------------------------|--------------------------------------------------------------------------------------------------|
| Wrong wire connection, or poor connection | Check the wiring status according to circuit diagram                                                                                                                | Connect wires according to wiring diagram to make sure all wiring terminals are connected firmly |
| Capacity of compressor is damaged         | Measure the capacity of fan capacitor with an universal meter and find that the capacity is out of the deviation range indicated on the nameplate of fan capacitor. | Replace the compressor capacitor                                                                 |
| Power voltage is a little low or high     | Use universal meter to measure the power supply voltage. The voltage is a little high or low                                                                        | Suggest to equip with voltage regulator                                                          |
| Coil of compressor is burnt out           | Use universal meter to measure the resistance between compressor terminals and it's 0                                                                               | Repair or replace compressor                                                                     |
| Cylinder of compressor is blocked         | Compressor can't operate                                                                                                                                            | Repair or replace compressor                                                                     |

#### 6. Air Conditioner is Leaking

| Possible causes       | Discriminating method (air conditioner status)              | Troubleshooting                                     |
|-----------------------|-------------------------------------------------------------|-----------------------------------------------------|
| Drain pipe is blocked | Water leaking from indoor unit                              | Eliminate the foreign objects inside the drain pipe |
| Drain pipe is broken  | Water leaking from drain pipe                               | Replace drain pipe                                  |
| Wrapping is not tight | Water leaking from the pipe connection place of indoor unit | Wrap it again and bundle it tightly                 |

#### 7. Abnormal Sound and Vibration

| Possible causes                                                                                             | Discriminating method (air conditioner status)                   | Troubleshooting                                                                                                                      |
|-------------------------------------------------------------------------------------------------------------|------------------------------------------------------------------|--------------------------------------------------------------------------------------------------------------------------------------|
| When turn on or turn off the unit, the panel and other parts will expand and there's abnormal sound         | There's the sound of "PAPA"                                      | Normal phenomenon. Abnormal sound will disappear after a few minutes.                                                                |
| When turn on or turn off the unit, there's abnormal sound due to flow of refrigerant inside air conditioner | Water-running sound can be heard                                 | Normal phenomenon. Abnormal sound will disappear after a few minutes.                                                                |
| Foreign objects inside the indoor unit or there're parts touching together inside the indoor unit           | There's abnormal sound fro indoor unit                           | Remove foreign objects. Adjust all parts' position of indoor unit, tighten screws and stick damping plaster between connected parts  |
| Foreign objects inside the outdoor unit or there're parts touching together inside the outdoor unit         | There's abnormal sound fro outdoor unit                          | Remove foreign objects. Adjust all parts' position of outdoor unit, tighten screws and stick damping plaster between connected parts |
| Short circuit inside the magnetic coil                                                                      | During heating, the way valve has abnormal electromagnetic sound | Replace magnetic coil                                                                                                                |
| Abnormal shake of compressor                                                                                | Outdoor unit gives out abnormal sound                            | Adjust the support foot mat of compressor, tighten the bolts                                                                         |
| Abnormal sound inside the compressor                                                                        | Abnormal sound inside the compressor                             | If add too much refrigerant during maintenance, please reduce refrigerant properly. Replace compressor for other circumstances.      |



# 11. Removal Procedure

 **Caution: discharge the refrigerant completely before removal.**

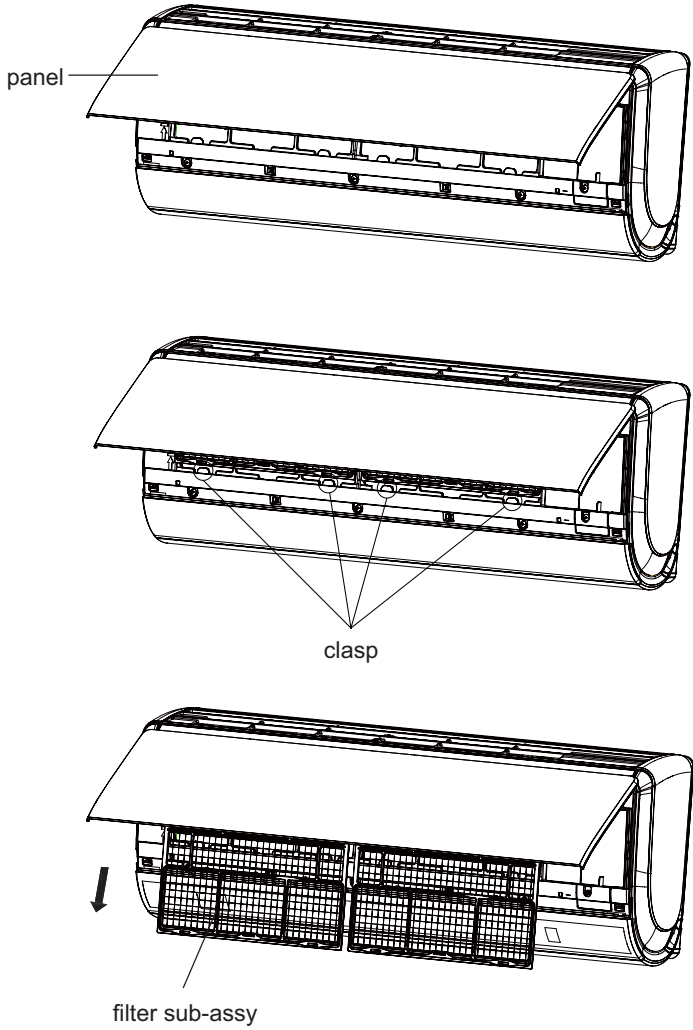
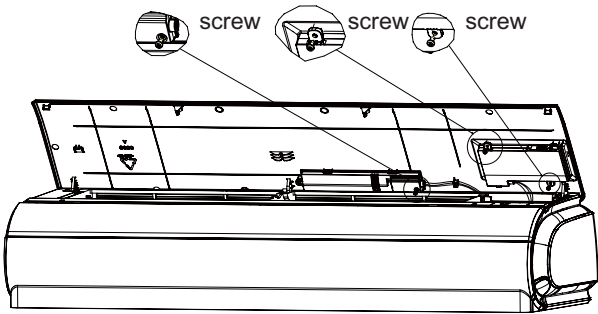
## 11.1 Removal Procedure of Indoor Unit

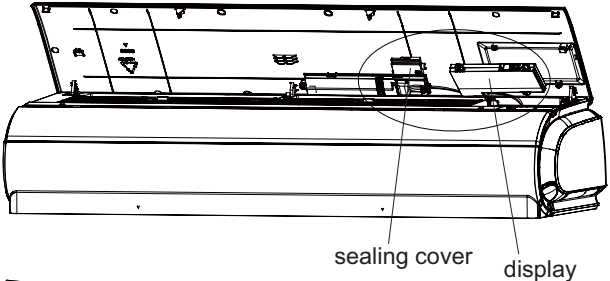
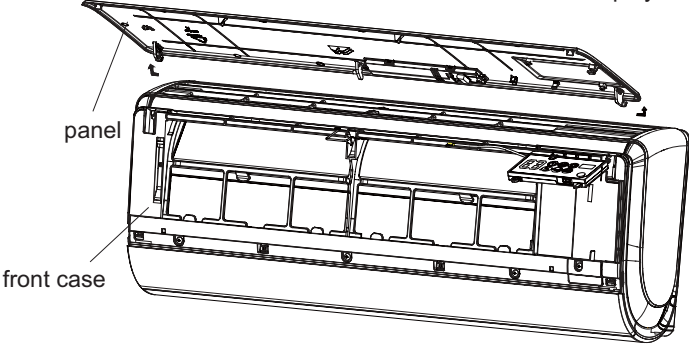
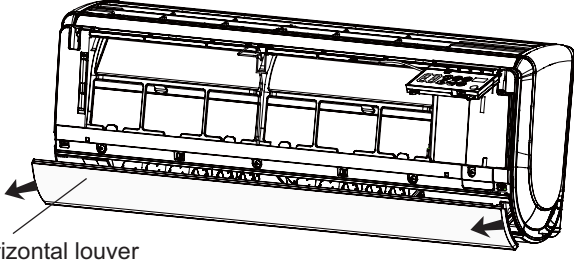
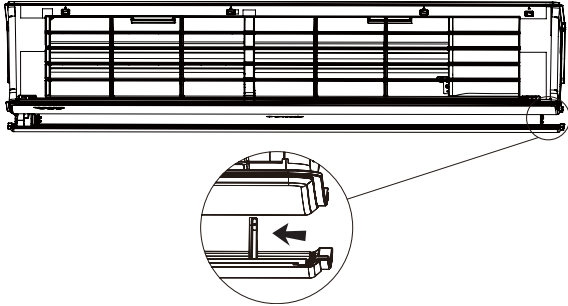
| Steps                     |                                                                         | Procedure                                                                                                                                                                                                                                                                                                                                                                                                                                                                                                                                                 |
|---------------------------|-------------------------------------------------------------------------|-----------------------------------------------------------------------------------------------------------------------------------------------------------------------------------------------------------------------------------------------------------------------------------------------------------------------------------------------------------------------------------------------------------------------------------------------------------------------------------------------------------------------------------------------------------|
| 1. Remove filter sub-assy |                                                                         |  <p>The diagram illustrates the removal of the filter sub-assembly in three steps:</p> <ul style="list-style-type: none"> <li><b>a</b> Open the panel. The top cover of the indoor unit is shown being lifted.</li> <li><b>b</b> Remove clasps on filter. The filter is held in place by several clasps, which are shown being released.</li> <li><b>c</b> Remove filter sub-assy with hand. The filter sub-assembly is shown being pulled out of the unit.</li> </ul> |
| 2. Remove panel           |                                                                         |  <p>The diagram shows the panel being removed by unscrewing three screws from the sealing cover. The screws are labeled 'screw'.</p>                                                                                                                                                                                                                                                                                                                                  |
| a                         | Remove 3 screws on sealing cover of panel and display with screwdriver. |                                                                                                                                                                                                                                                                                                                                                                                                                                                                                                                                                           |

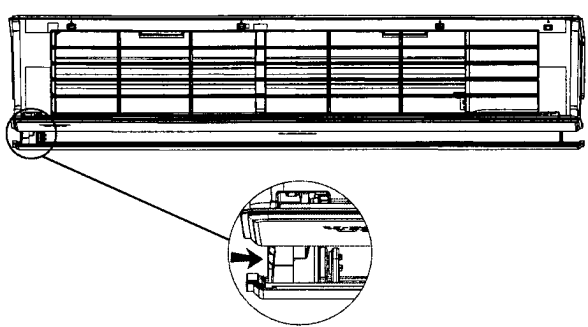
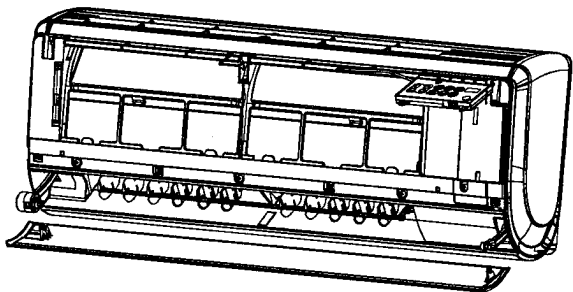
| Steps                                      |                                                                                                                                                              | Procedure                                                                                                                                                                                                                                                                                                             |
|--------------------------------------------|--------------------------------------------------------------------------------------------------------------------------------------------------------------|-----------------------------------------------------------------------------------------------------------------------------------------------------------------------------------------------------------------------------------------------------------------------------------------------------------------------|
| b                                          | Remove sealing cover and display.                                                                                                                            |  <p>The diagram shows a perspective view of the top of the unit. A circular callout highlights the area where the sealing cover and display are attached. Labels 'sealing cover' and 'display' point to these components.</p>       |
| c                                          | Remove hinges at both sides of panel to separate panel and front case and then remove the panel.                                                             |  <p>The diagram shows the front case with the panel being lifted away from it. Labels 'panel' and 'front case' identify the respective parts.</p>                                                                                   |
| 3. Remove horizontal louver and front case |                                                                                                                                                              |                                                                                                                                                                                                                                                                                                                       |
| a                                          | Cut off power, hold both ends of horizontal louver with hand, and then draw it out horizontally.                                                             |  <p>The diagram shows the front case with the horizontal louver being pulled out. An arrow points to the louver, and another arrow indicates the direction of movement.</p>                                                       |
| b                                          | Remove right end at first. Hold the right end of horizontal louver, push the connection rod with thumb to separate the connection rod and horizontal louver. |  <p>The diagram shows the horizontal louver with the connection rod being pushed out. A circular callout provides a close-up view of the connection rod being pushed out, with an arrow indicating the direction of movement.</p> |

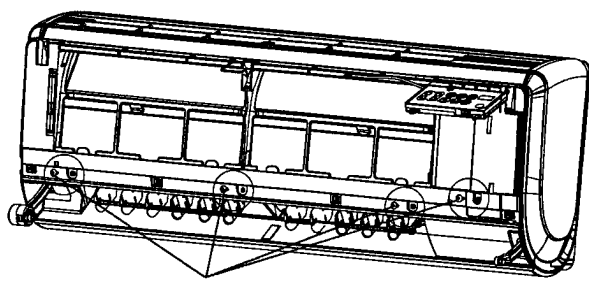
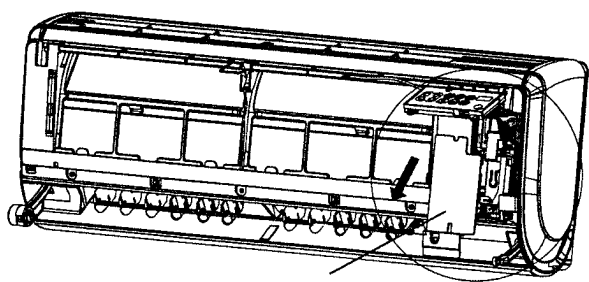
| Steps | Procedure                                                                                                                                                                                           | Procedure                                                                                                      |
|-------|-----------------------------------------------------------------------------------------------------------------------------------------------------------------------------------------------------|----------------------------------------------------------------------------------------------------------------|
| c     | Remove the left end. Hold the end of connection rod with left hand, hold the horizontal louver with right hand to separate connection rod and horizontal louver.                                    |                              |
| d     | Remove the horizontal louver along the axle center direction.                                                                                                                                       |                              |
| e     | Note: (during operation, install the left end and then install the right end. After installation, re-energize the unit until the horizontal louver is reset. After that, you can operate the unit). |                            |
| f     | Remove 4 screws on front case and electric box cover with screwdriver.                                                                                                                              |  <p>screws</p>             |
| g     | Remove electric box cover.                                                                                                                                                                          |  <p>electric box cover</p> |

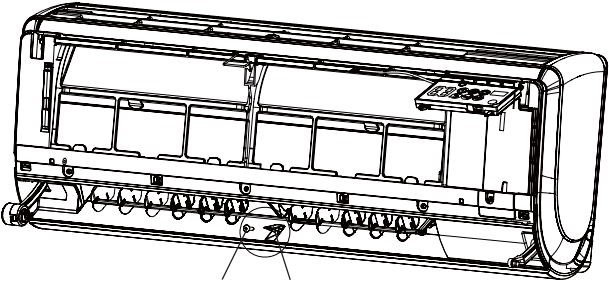
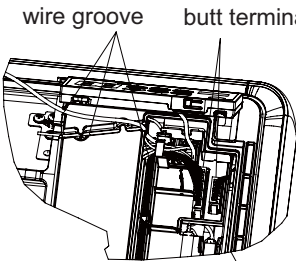
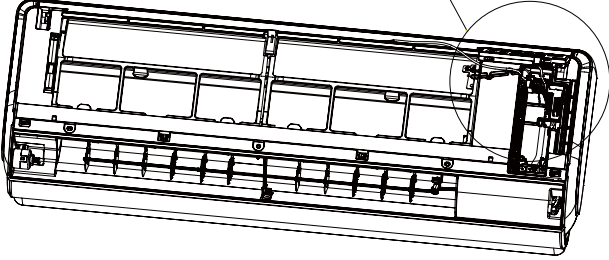
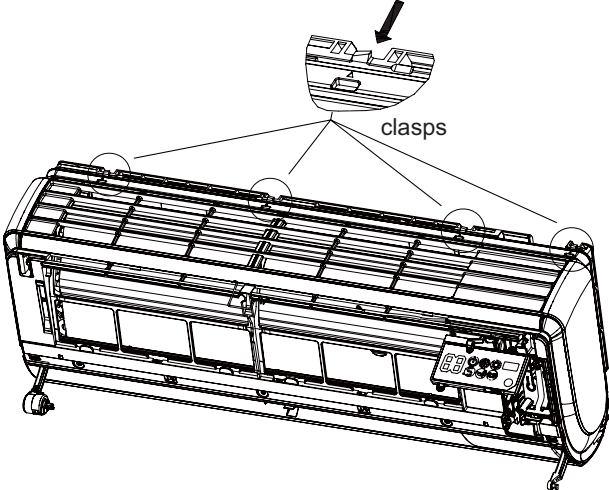
| Steps |                                                                                                                                                                                                  | Procedure                                                                                                                                                                                                                       |
|-------|--------------------------------------------------------------------------------------------------------------------------------------------------------------------------------------------------|---------------------------------------------------------------------------------------------------------------------------------------------------------------------------------------------------------------------------------|
| h     | <p>Turn over the screw cover on front case with hand, and then remove one screw inside the screw cover with screwdriver.</p>                                                                     |  <p>screw screw cover</p>  <p>wire groove butt terminal</p> |
| i     | <p>Pull out two butt terminals on electric box, and then take out connection wire of butt terminal, connection wire of inspection board and wire of temperature sensor from the wire groove.</p> |                                                                                                                                             |
| j     | <p>Open 4 clasps at left, middle and right side of front case with hand.</p>                                                                                                                     |  <p>clasps</p>                                                                                                                              |

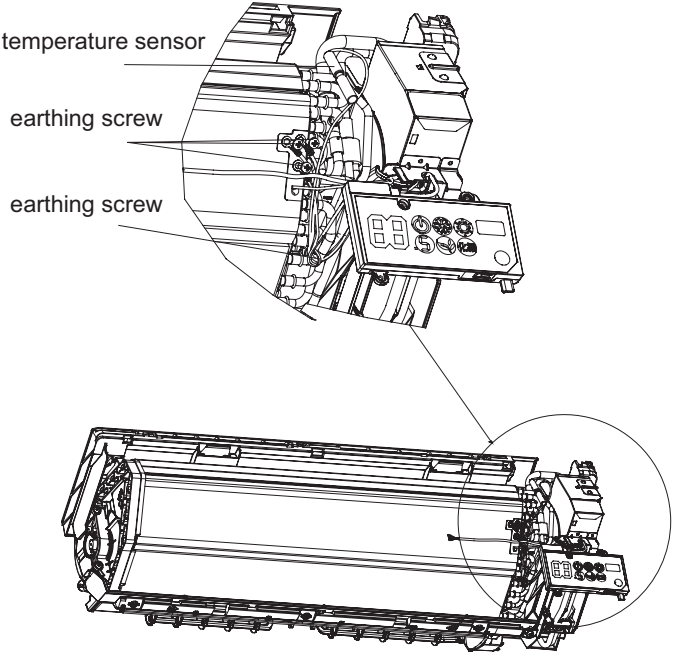
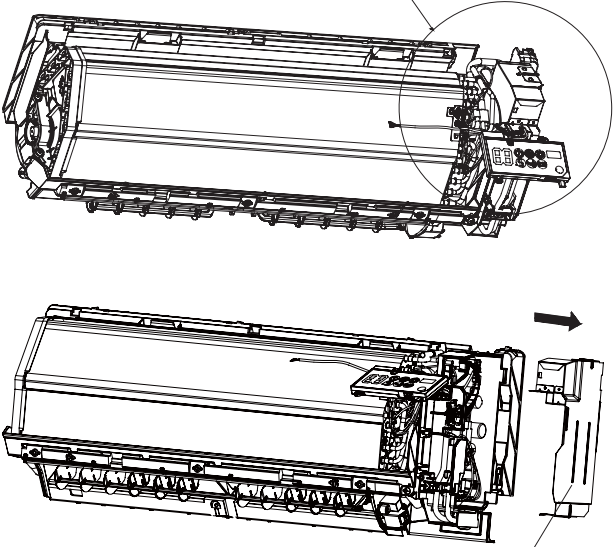
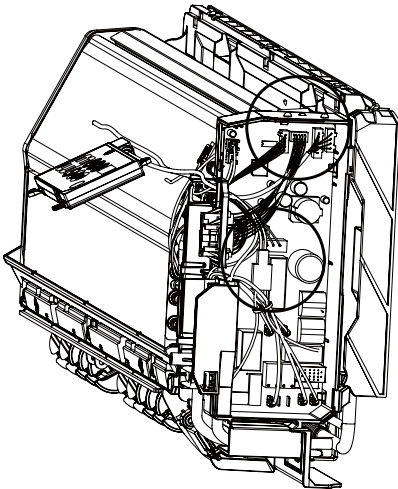
| Steps                                                                                                                                                        | Procedure                                                                                                                                                                                                                                                                                    |
|--------------------------------------------------------------------------------------------------------------------------------------------------------------|----------------------------------------------------------------------------------------------------------------------------------------------------------------------------------------------------------------------------------------------------------------------------------------------|
| 4. Remove electric box                                                                                                                                       |                                                                                                                                                                                                                                                                                              |
| <p>a</p> <p>Remove three earthing screws with screws, pull out the indoor tube temperature sensor with hand and then cut off the tileline with scissors.</p> | <p>temperature sensor</p> <p>earthing screw</p> <p>earthing screw</p>   <p>shielding cover sub-assy of electric box</p> |
| 5. Remove evaporator                                                                                                                                         |                                                                                                                                                                                                                                                                                              |
| <p>a</p> <p>Pull out the power plug from motor and stepping motor.</p>                                                                                       |                                                                                                                                                                                                          |

b Remove screws fixing electric box with screwdriver, and then take out the wires from the wire groove of electric box with hand.

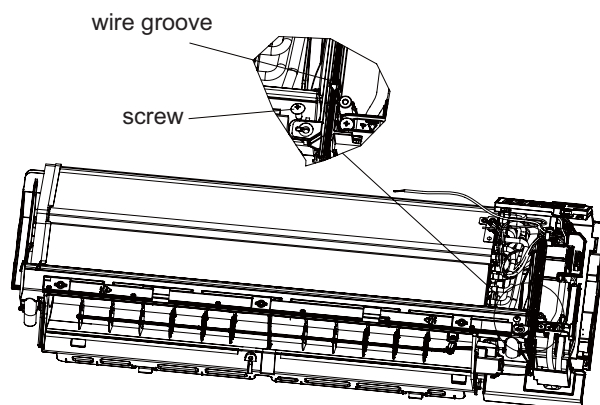

c Remove screw from press plate of connection pipe with screwdriver.

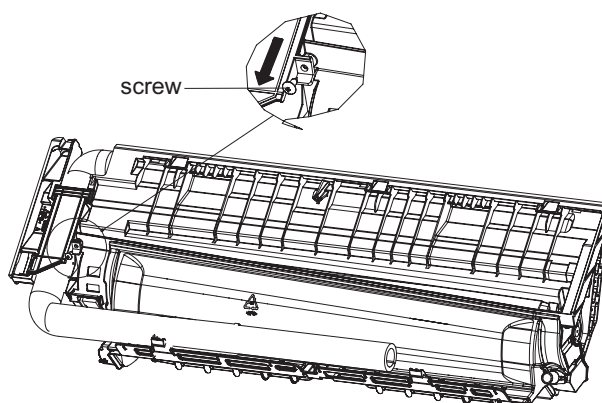

d Remove press plate of connection pipe with hand to separate it from the bottom case.

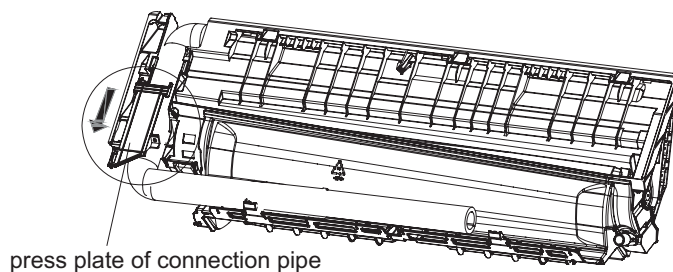

e Remove 2 screws at the connection position of evaporator and bottom case with screwdriver.

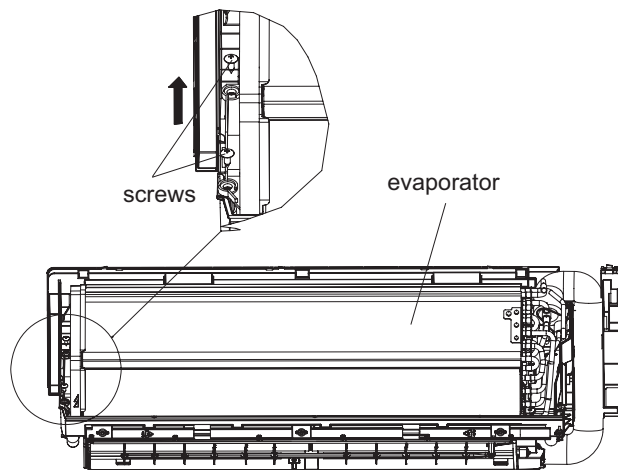

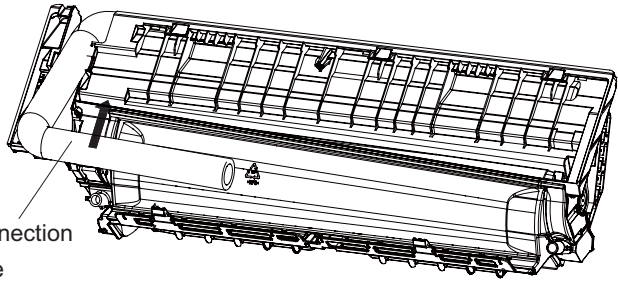
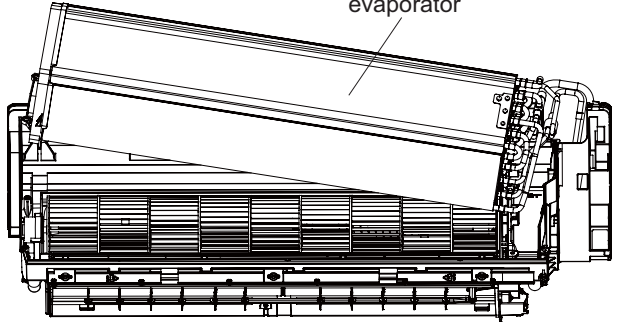
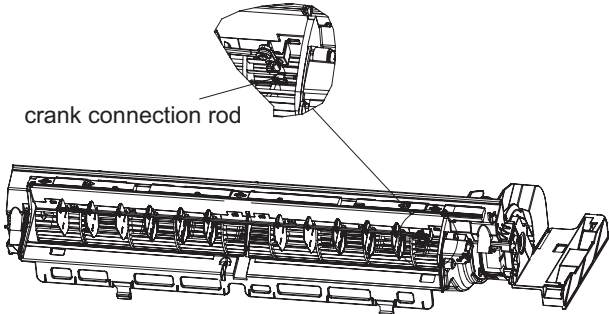
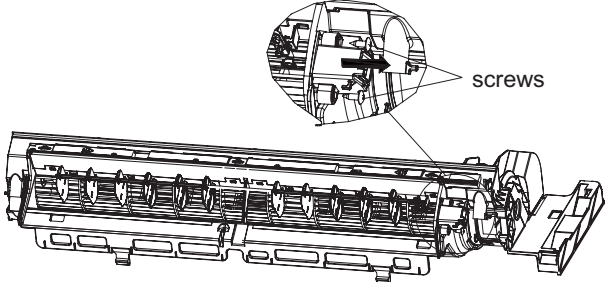
| Steps                 | Procedure                                                                       |                                                                                                                  |
|-----------------------|---------------------------------------------------------------------------------|------------------------------------------------------------------------------------------------------------------|
| f                     | Open the connection pipe of evaporator with hand.                               |  <p>connection pipe</p>        |
| g                     | Lift up the left end of evaporator with hand, and then take out the evaporator. |  <p>evaporator</p>             |
| 6. Remove swing blade |                                                                                 |                                                                                                                  |
| a                     | Remove crank connection rod.                                                    |  <p>crank connection rod</p> |
| b                     | Remove 2 screws fixing swing motor cover with screwdriver.                      |  <p>screws</p>               |

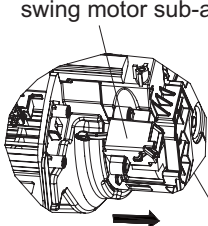
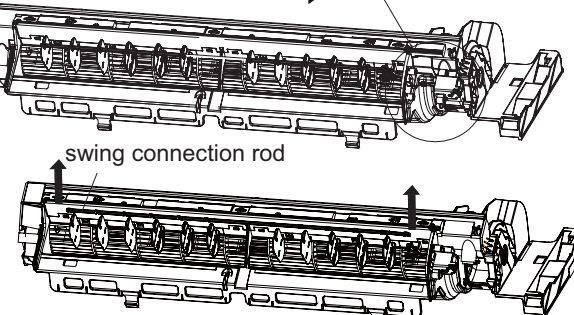
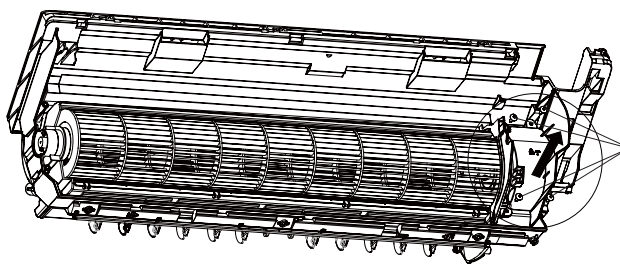
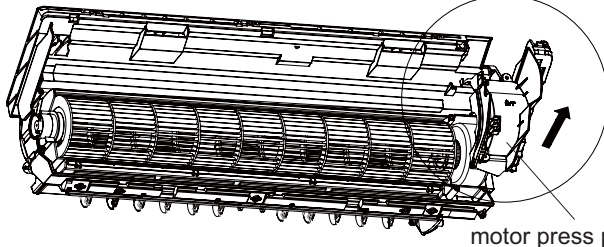
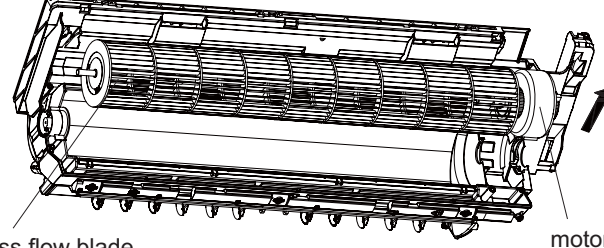
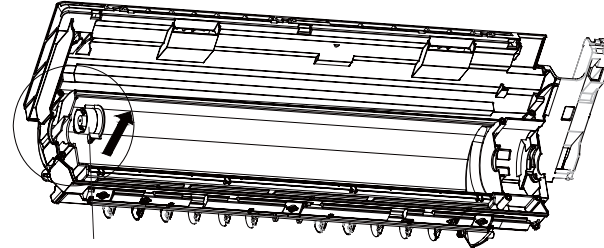
| Steps                                | Procedure                                                          | Diagram                                                                                                                   |
|--------------------------------------|--------------------------------------------------------------------|---------------------------------------------------------------------------------------------------------------------------|
| c                                    | Remove swing motor sub-assy.                                       |  <p>swing motor sub-assy</p>            |
| d                                    | Take out swing connection rod to separate it from the swing blade. |  <p>swing connection rod</p>            |
| 7. Remove cross flow blade and motor |                                                                    |                                                                                                                           |
| a                                    | Remove 4 screws fixing the motor press plate with screwdriver.     |  <p>screws</p>                         |
| b                                    | Take out the motor press plate.                                    |  <p>motor press plate</p>             |
| c                                    | Take out cross flow blade and motor.                               |  <p>cross flow blade</p> <p>motor</p> |
| d                                    | Pull out the shaft rubber cushion block with hand.                 |  <p>shaft rubber cushion block</p>    |

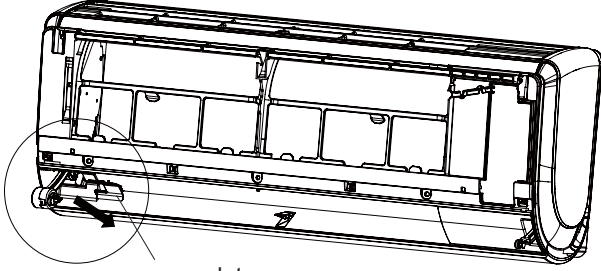
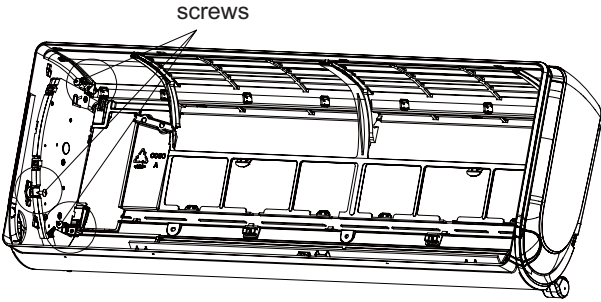
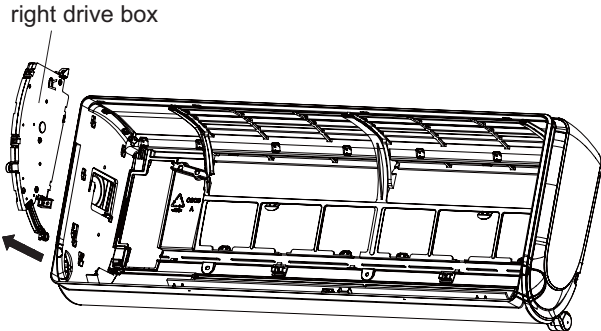
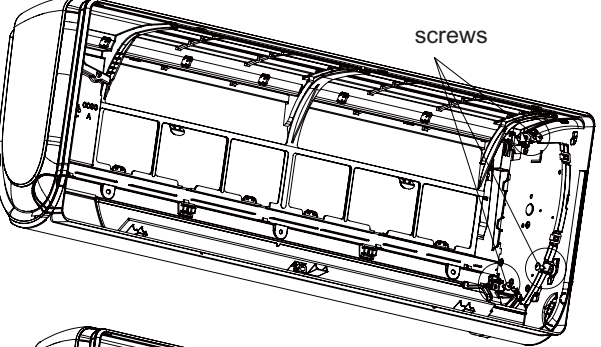
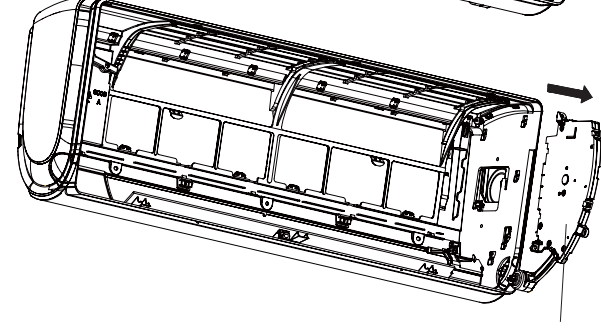
| Steps               | Procedure                                                                                                                                                           |
|---------------------|---------------------------------------------------------------------------------------------------------------------------------------------------------------------|
| 8. Remove drive box |                                                                                                                                                                     |
| a                   | <p>Remove the left side cover plate of front case.</p>  <p>cover plate</p>        |
| b                   | <p>Remove 3 screws fixing the left drive box with screwdriver.</p>  <p>screws</p> |
| c                   | <p>Take out right drive box.</p>  <p>right drive box</p>                         |
| d                   | <p>Remove 3 screws fixing left drive box with screwdriver.</p>  <p>screws</p>   |
| e                   | <p>Take out the left drive box.</p>  <p>left drive box</p>                      |

## 11.2 Removal Procedure of Outdoor Unit

**⚠ Warning:** Be sure to wait for a minimum of 20 minutes after turning off all power supplies and discharge the refrigerant completely before removal.

13K

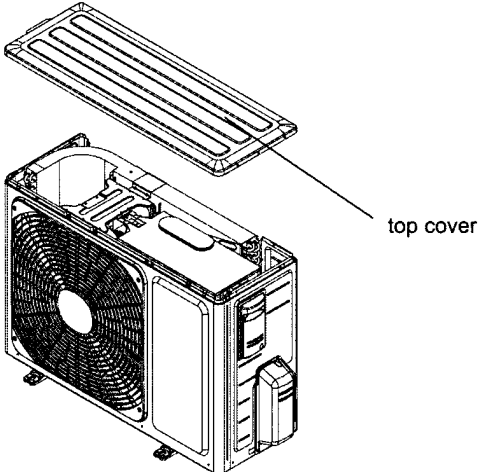
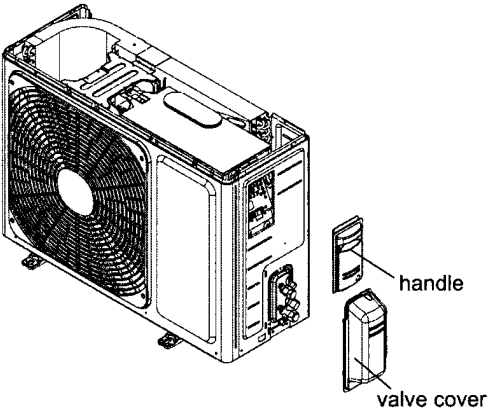
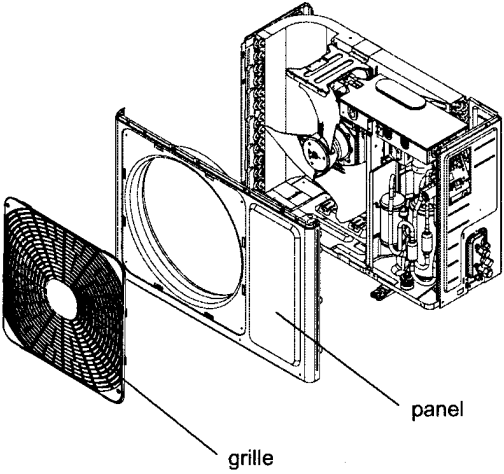
| Steps                            | Procedure                                                                                                                                               |                                                                                                                    |
|----------------------------------|---------------------------------------------------------------------------------------------------------------------------------------------------------|--------------------------------------------------------------------------------------------------------------------|
| 1. Remove top cover              | Remove the screws connecting top cover, left and right side plate, as well as panel, to remove the top cover.                                           |  <p>top cover</p>               |
| 2. Remove handle and valve cover | Remove the screws connecting handle and right side plate, to remove the handle. Remove the screw fixing valve cover, to remove the cover.               |  <p>handle<br/>valve cover</p> |
| 3. Remove panel and grille       | Remove the screws fixing panel, to remove the panel. Remove the screws connecting panel grille and panel, loosen the clamp, to remove the panel grille. |  <p>grille<br/>panel</p>       |

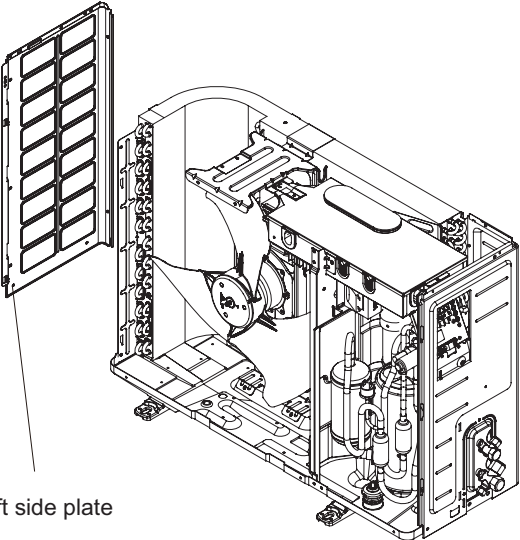
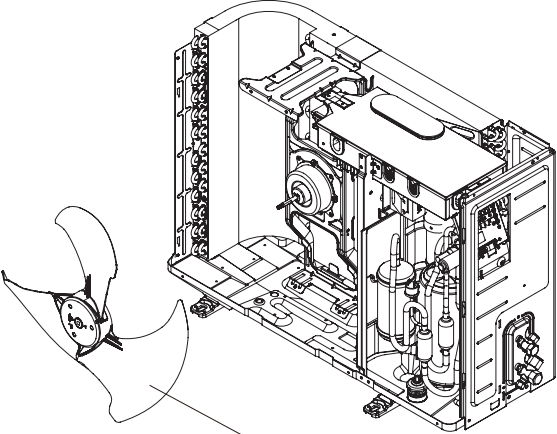
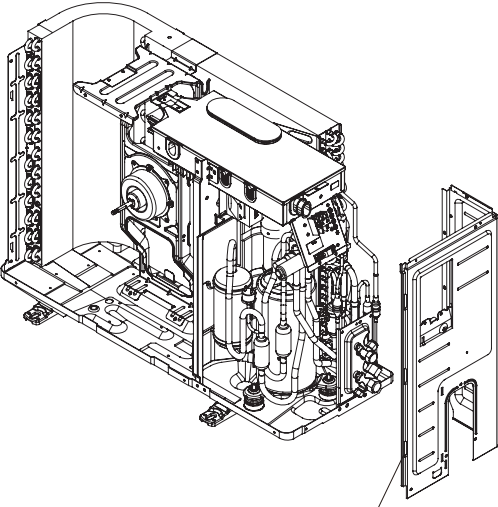
| Steps                      | Procedure                                                                                                                                                                                                                                                                                         |
|----------------------------|---------------------------------------------------------------------------------------------------------------------------------------------------------------------------------------------------------------------------------------------------------------------------------------------------|
| 4. Remove left side plate  | <p data-bbox="252 479 767 577">Remove the screws fixing left side plate and condenser support board, to remove the left side plate.</p>  <p data-bbox="874 792 1011 819">left side plate</p>                    |
| 5. Remove cross fan blade  | <p data-bbox="252 1155 807 1254">Remove the screw nut fixing cross fan blade, remove the gasket and spring cushion, to remove the cross fan blade.</p>  <p data-bbox="1091 1442 1251 1469">cross fan blade</p> |
| 6. Remove right side plate | <p data-bbox="252 1738 791 1800">Remove the screws fixing right side plate and valve support, to remove the right side plate.</p>  <p data-bbox="1155 2018 1315 2045">right side plate</p>                    |

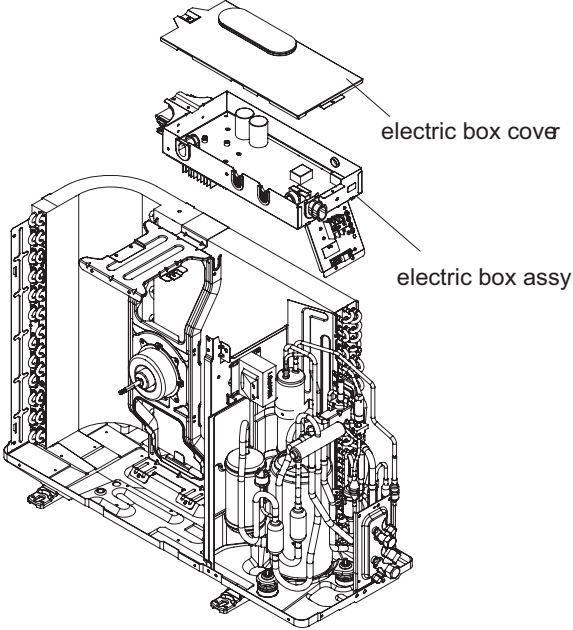
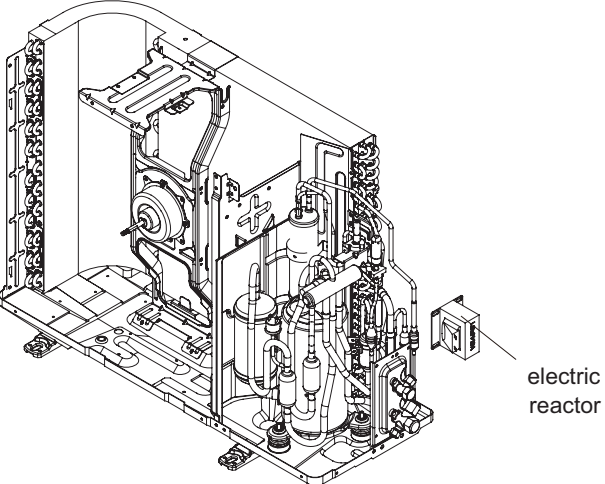
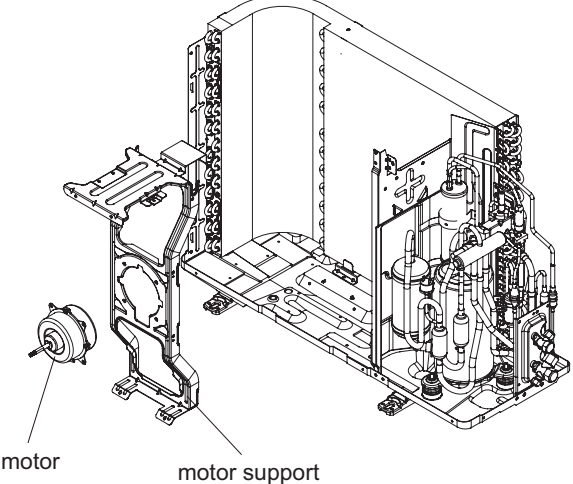
| Steps                                    | Procedure                                                                                                                                                                                                                                                                                                 |
|------------------------------------------|-----------------------------------------------------------------------------------------------------------------------------------------------------------------------------------------------------------------------------------------------------------------------------------------------------------|
| <p>7. Remove electric box assy</p>       | <p>Remove screws fixing electric box assy and mid-isolation board, loosen the bonding tie, pull off the wiring terminal, lift to remove the electric box assy.</p>                                                      |
| <p>8. Remove electric reactor</p>        | <p>Remove the screws fixing electric reactor, to remove the electric reactor.</p>                                                                                                                                      |
| <p>9. Remove motor and motor support</p> | <p>Remove the four tapping screws fixing motor, pull out the contact tag of motor wiring, to remove the motor. Remove the two tapping screws fixing motor support and chassis, lift to remove the motor support.</p>  |

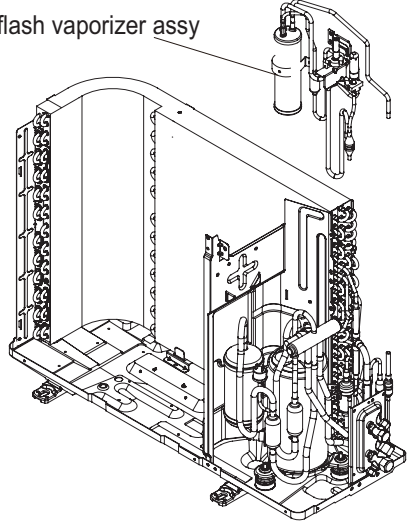
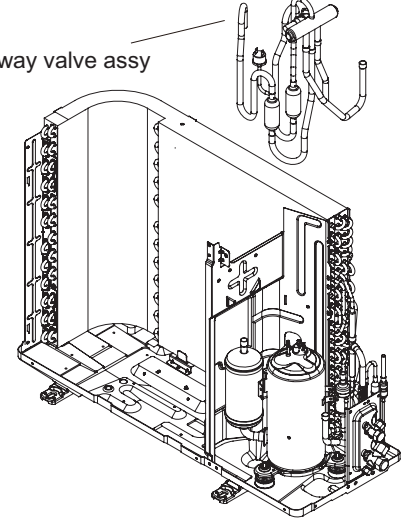
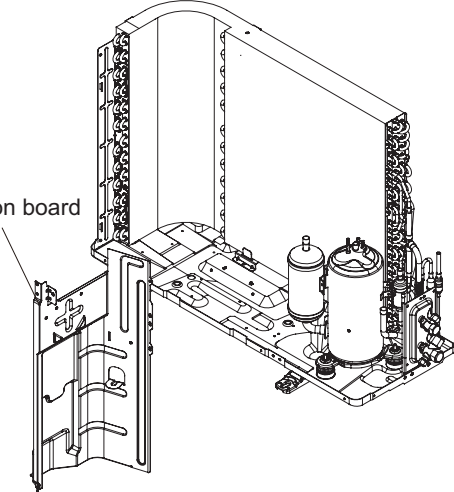
| Steps                           | Procedure                                                                                                                                                                                                                                                                                                                                                                                                   |
|---------------------------------|-------------------------------------------------------------------------------------------------------------------------------------------------------------------------------------------------------------------------------------------------------------------------------------------------------------------------------------------------------------------------------------------------------------|
| 10. Remove flash vaporizer assy | <p data-bbox="252 472 794 539">Remove the screws connecting mid-isolation board, lift to remove the flash vaporizer assy.</p>  <p data-bbox="954 371 1155 398">flash vaporizer assy</p>                                                                                                                                   |
| 11. Remove four-way valve assy  | <p data-bbox="252 1111 807 1285">Welding cut the spot weld of four-way valve assy, compressor air suction/discharging valve and condenser pipe outlet, lift to remove the four-way valve assy.<br/>(Note: release the refrigerant before welding cutting.)</p>  <p data-bbox="903 976 1104 1003">four-way valve assy</p> |
| 12. Remove mid-isolation board  | <p data-bbox="252 1731 794 1832">Remove the screws connecting mid-isolation board, chassis and condenser assy, to remove the mid-isolation.</p>  <p data-bbox="839 1686 1034 1713">mid-isolation board</p>                                                                                                              |

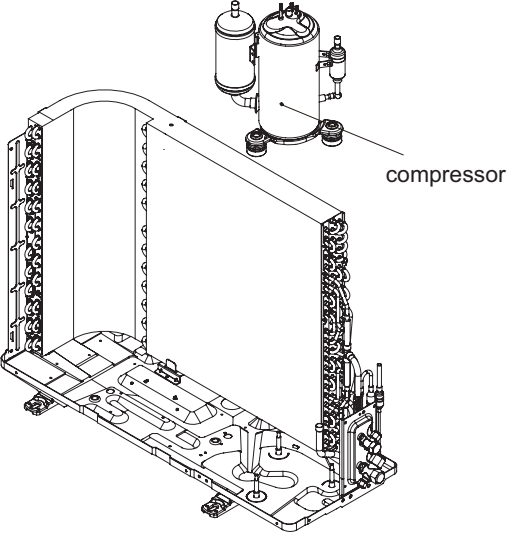
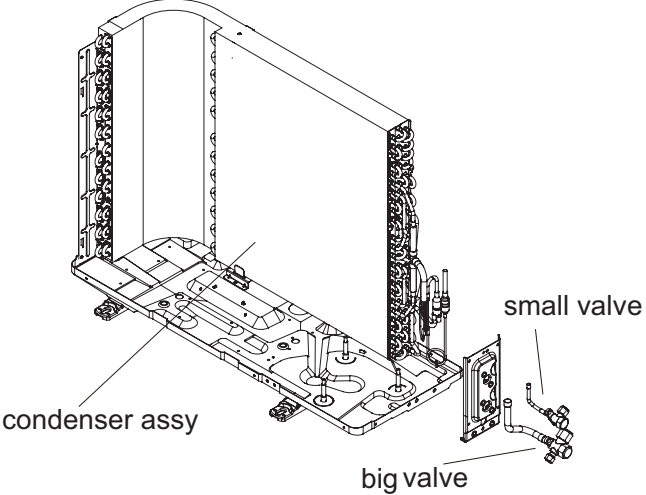
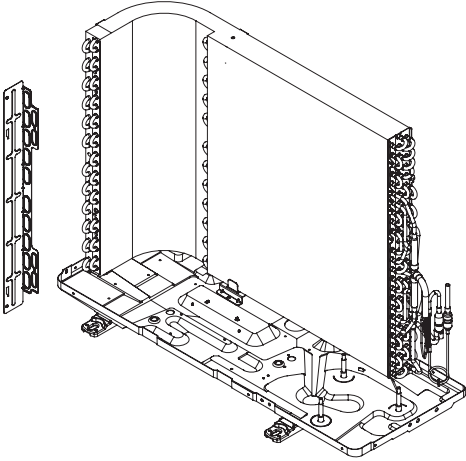
| Steps                                      | Procedure                                                                                                                                                                                                                                             |
|--------------------------------------------|-------------------------------------------------------------------------------------------------------------------------------------------------------------------------------------------------------------------------------------------------------|
| <p>13. Remove compressor</p>               | <p>Remove the three feet screwnuts fixing compressor, to remove the compressor.</p>                                                                                 |
| <p>14. Remove big and small valve assy</p> | <p>Remove screws connecting condenser assy and chassis, to remove the condenser assy.<br/>Remove the screws fixing big and small valve, to remove the valves.</p>  |
| <p>15. Remove chassis sub-assy</p>         | <p>Remove screws connecting condenser assy and chassis, to remove the chassis sub-assy.</p>                                                                       |

18K

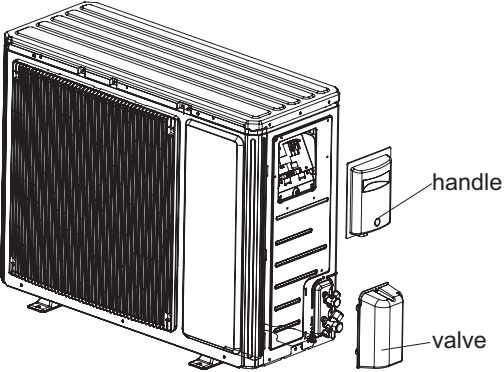
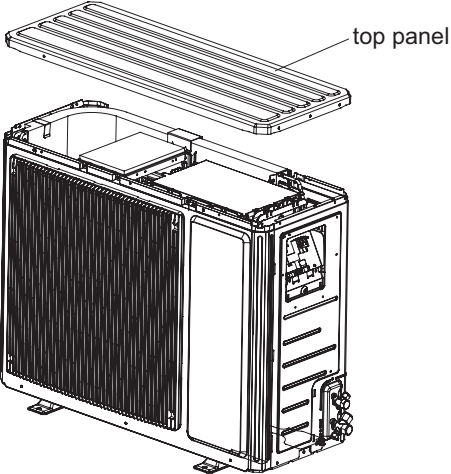
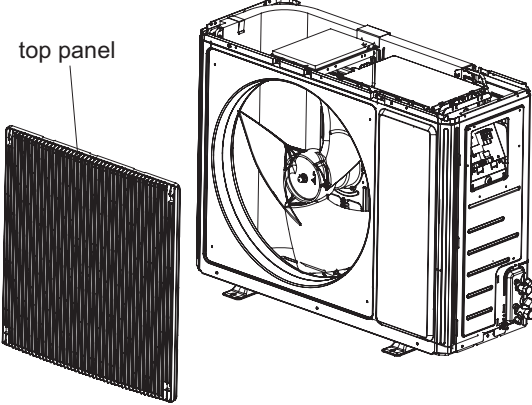
| Steps                                  | Procedure                                                                                                                                                                                                                                                                                                                                                                                                                                                                                           |
|----------------------------------------|-----------------------------------------------------------------------------------------------------------------------------------------------------------------------------------------------------------------------------------------------------------------------------------------------------------------------------------------------------------------------------------------------------------------------------------------------------------------------------------------------------|
| 1. Remove top panel                    | <p data-bbox="124 495 718 573">1 Twist off the screws used for fixing the handle and valve cover, pull the handle and valve cover upward to remove it.</p>  <p data-bbox="124 1003 654 1115">2 Remove the 3 screws connecting the top panel with the front panel and the right side plate, and then remove the top panel.</p>  |
| 2. Remove grille, panel and rear grill | <p data-bbox="124 1644 654 1711">1 Remove the 2 screws connecting the grille and the panel, and then remove the grille.</p>                                                                                                                                                                                                                                                                                     |

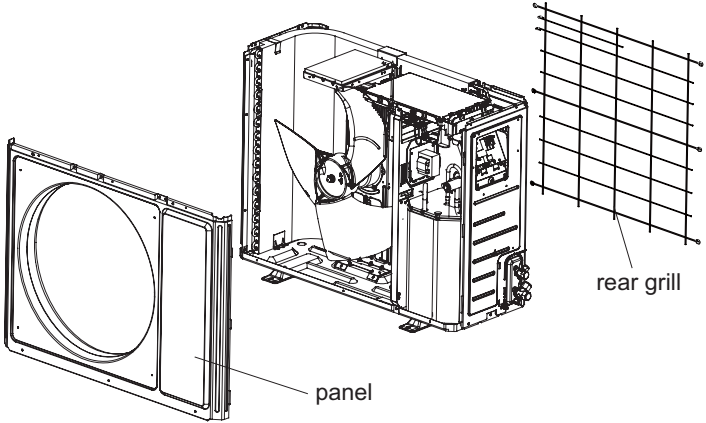
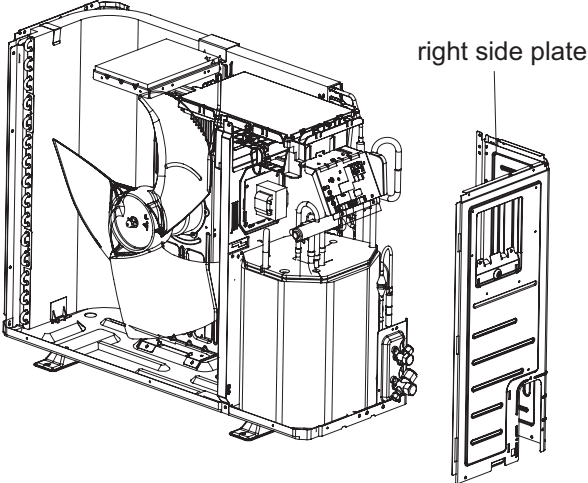
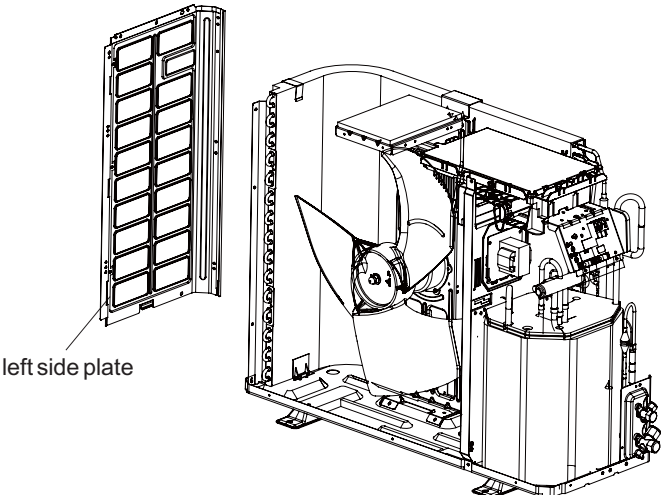
| Steps                                          | Procedure                                                                                                                                                                                                                    |                                                                                                                                                                                                                                                                 |
|------------------------------------------------|------------------------------------------------------------------------------------------------------------------------------------------------------------------------------------------------------------------------------|-----------------------------------------------------------------------------------------------------------------------------------------------------------------------------------------------------------------------------------------------------------------|
| 2                                              | <p>Remove the 5 screws connecting the panel with the chassis and the motor support, and then remove the panel.</p> <p>Remove the 6 screws connecting the left side plate and right side plate and then remove rear grill</p> |  <p>Diagram illustrating the removal of the panel and rear grill. The panel is shown detached from the chassis, and the rear grill is shown as a separate grid component.</p> |
| 3. Remove left side plate and right side plate |                                                                                                                                                                                                                              |                                                                                                                                                                                                                                                                 |
| 1                                              | <p>Remove the screws connecting the right side plate with the chassis, the valve support and the electric box, and then remove the right side plate assy.</p>                                                                |  <p>Diagram illustrating the removal of the right side plate. The right side plate is shown detached from the chassis.</p>                                                   |
| 2                                              | <p>Remove the screws connecting the left side plate and the chassis, and then remove the left side plate assy.</p>                                                                                                           |  <p>Diagram illustrating the removal of the left side plate. The left side plate is shown detached from the chassis.</p>                                                    |

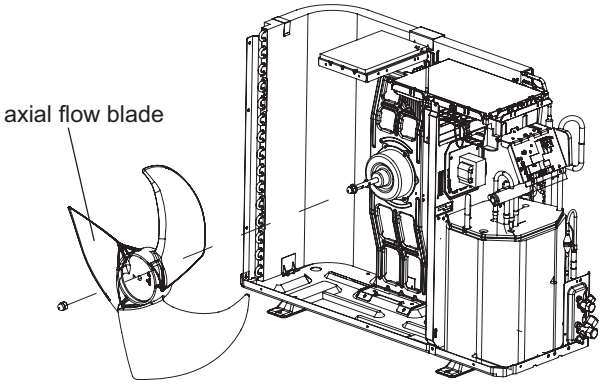
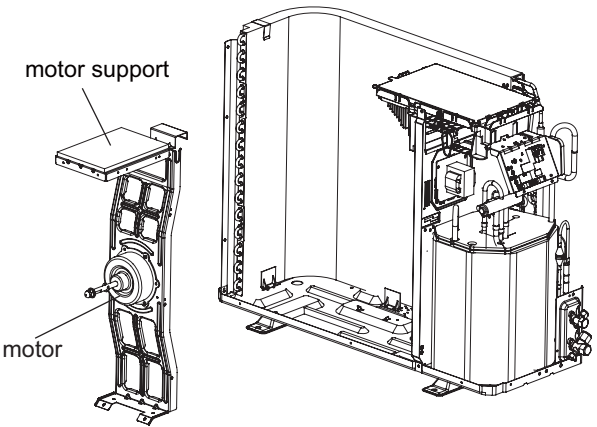
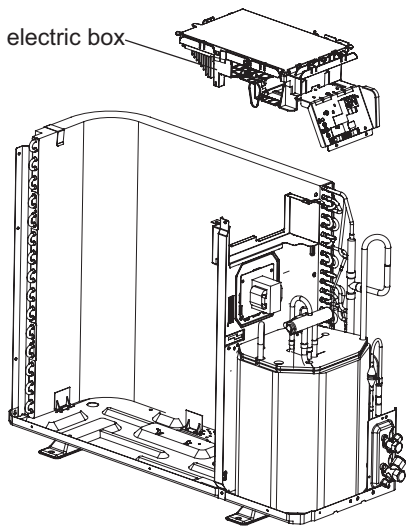
| Steps                  | Procedure                                                                                                                                                                                                                           |                                                                                                                       |
|------------------------|-------------------------------------------------------------------------------------------------------------------------------------------------------------------------------------------------------------------------------------|-----------------------------------------------------------------------------------------------------------------------|
| 4. Remove fan motor    |                                                                                                                                                                                                                                     |                                                                                                                       |
| 1                      | Remove the nuts fixing the blade and then remove the axial flow blade.                                                                                                                                                              |  <p>axial flow blade</p>            |
| 2                      | Remove the 4 tapping screws fixing the motor; disconnect the leading wire insert of the motor and then remove the motor. Remove the 2 tapping screws fixing the motor support and then pull the motor support upwards to remove it. |  <p>motor support</p> <p>motor</p> |
| 5. Remove electric box |                                                                                                                                                                                                                                     |                                                                                                                       |
|                        | Remove the screws fixing the electric box sub-assy; loosen the wire bundle; pull out the wiring terminals and then pull the electric box upwards to remove it.                                                                      |  <p>electric box</p>              |

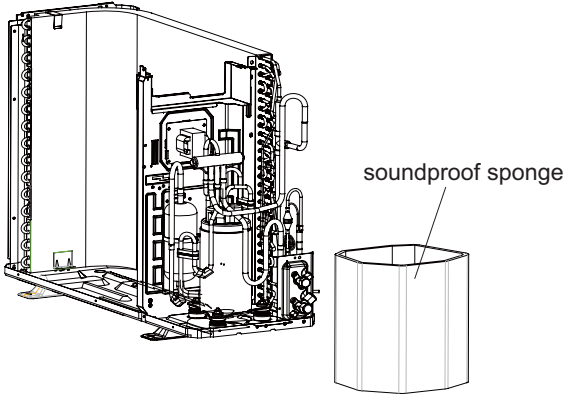
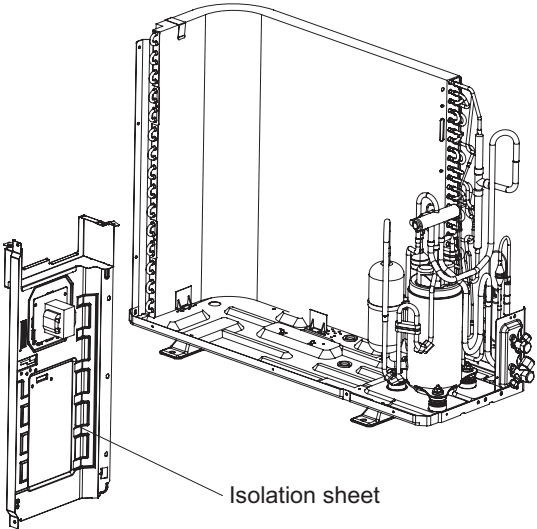
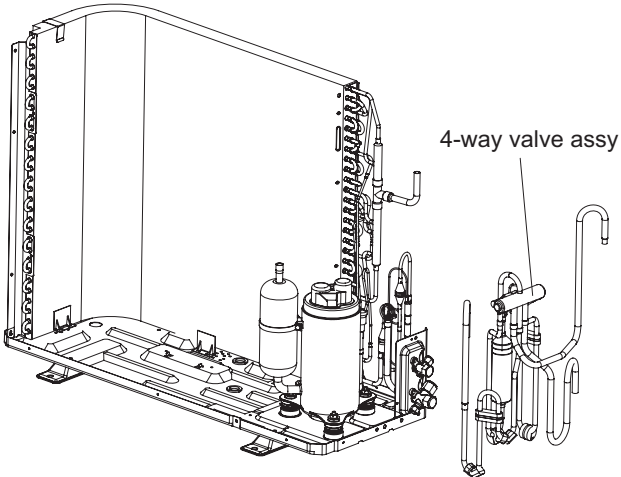
| Steps                             | Procedure                                                                                                                                                                                                                                                                                         |
|-----------------------------------|---------------------------------------------------------------------------------------------------------------------------------------------------------------------------------------------------------------------------------------------------------------------------------------------------|
| <p>6.Remove soundproof sponge</p> | <p>Since the piping ports on the soundproof sponge are torn easily, remove the soundproof sponge carefully</p>  <p style="text-align: right;">soundproof sponge</p>                                             |
| <p>7. Remove Isolation sheet</p>  | <p>Remove the 3 screws fixing the isolation sheet and then remove the Isolation sheet.</p>  <p style="text-align: right;">Isolation sheet</p>                                                                  |
| <p>8. Remove 4-way valve assy</p> | <p>Discharge the refrigerant completely;unsolder the pipelines connecting the compressor and the condenser assy,and then remove the 4-way valve assy.</p>  <p style="text-align: right;">4-way valve assy</p> |

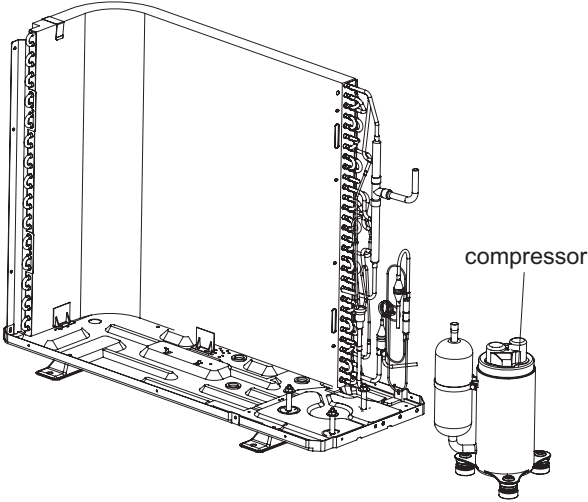
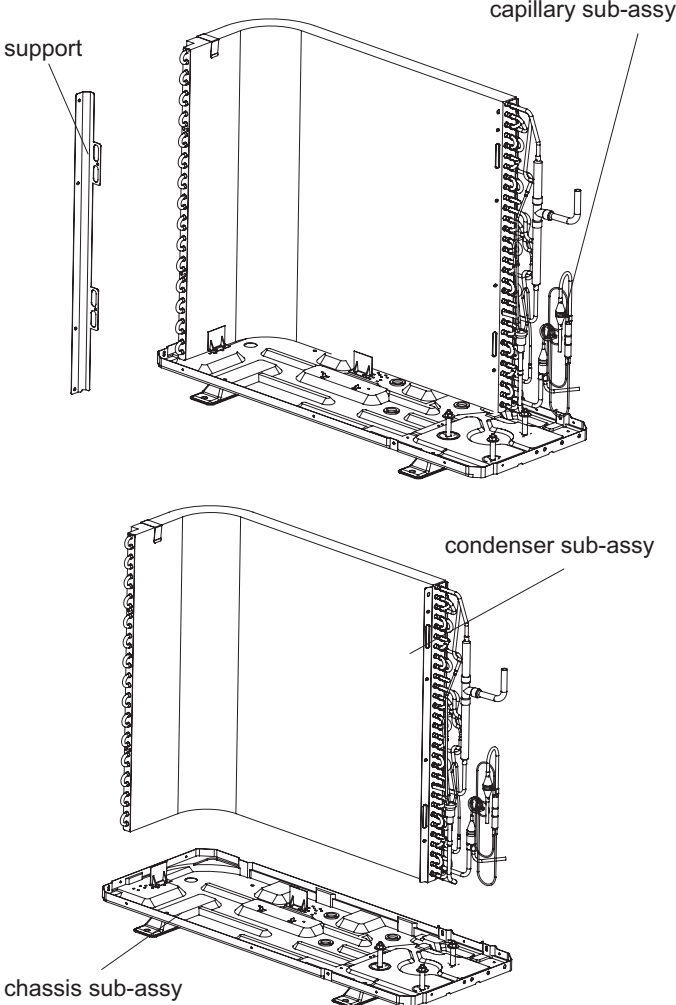
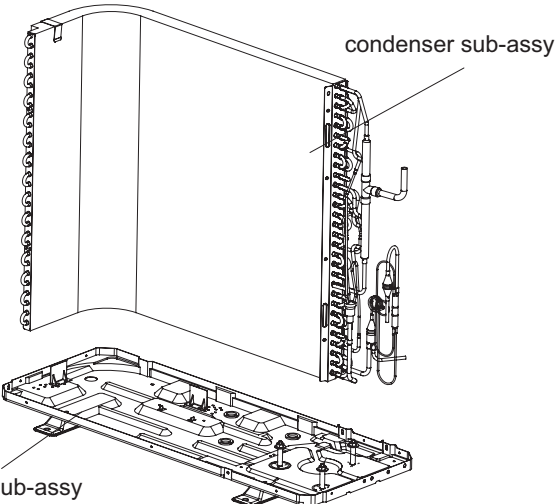
| Steps                                | Procedure                                                                                                                                                                                                                                                                                                                                                        |
|--------------------------------------|------------------------------------------------------------------------------------------------------------------------------------------------------------------------------------------------------------------------------------------------------------------------------------------------------------------------------------------------------------------|
| <p>9. Remove compressor</p>          | <p>Remove the 3 foot nuts fixing the compressor and then remove the compressor.</p>                                                                                                                                                                                            |
| <p>10. Remove condenser sub-assy</p> | <p>1 Remove the screws connecting the support (condenser) and condenser assy, and then remove the support (condenser).</p>  <p>2 Remove the chassis sub-assy and condenser sub-assy.</p>  |

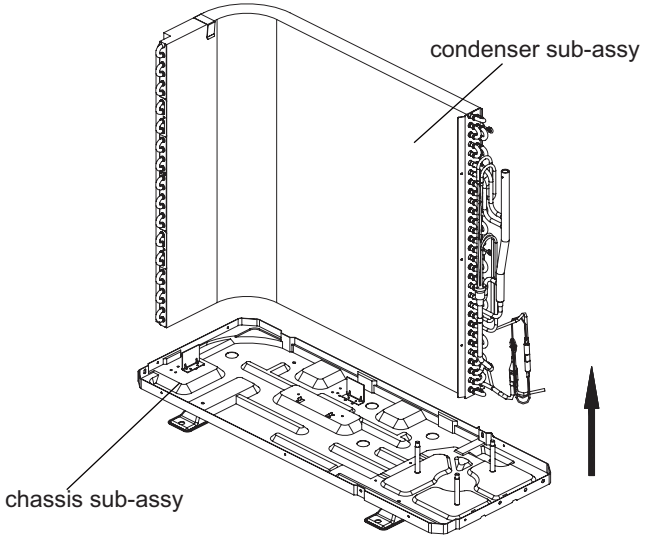
| Steps | Procedure                                                |                                                                                                                                                                                                                                                                                                                                                                             |
|-------|----------------------------------------------------------|-----------------------------------------------------------------------------------------------------------------------------------------------------------------------------------------------------------------------------------------------------------------------------------------------------------------------------------------------------------------------------|
| 2     | Disassemble the chassis sub-assy and condenser sub-assy. |  <p>The diagram illustrates the disassembly of two sub-assemblies. The chassis sub-assembly is shown at the bottom, and the condenser sub-assembly is shown at the top right. A vertical arrow points upwards from the chassis sub-assembly, indicating the direction of disassembly.</p> |

## Appendix:

### Appendix 1: Reference Sheet of Celsius and Fahrenheit

Conversion formula for Fahrenheit degree and Celsius degree:  $T_f = T_c \times 1.8 + 32$

#### Set temperature

| Fahrenheit display temperature (°F) | Fahrenheit (°F) | Celsius (°C) | Fahrenheit display temperature (°F) | Fahrenheit (°F) | Celsius (°C) | Fahrenheit display temperature (°F) | Fahrenheit (°F) | Celsius (°C) |
|-------------------------------------|-----------------|--------------|-------------------------------------|-----------------|--------------|-------------------------------------|-----------------|--------------|
| 61                                  | 60.8            | 16           | 69/70                               | 69.8            | 21           | 78/79                               | 78.8            | 26           |
| 62/63                               | 62.6            | 17           | 71/72                               | 71.6            | 22           | 80/81                               | 80.6            | 27           |
| 64/65                               | 64.4            | 18           | 73/74                               | 73.4            | 23           | 82/83                               | 82.4            | 28           |
| 66/67                               | 66.2            | 19           | 75/76                               | 75.2            | 24           | 84/85                               | 84.2            | 29           |
| 68                                  | 68              | 20           | 77                                  | 77              | 25           | 86                                  | 86              | 30           |

#### Ambient temperature

| Fahrenheit display temperature (°F) | Fahrenheit (°F) | Celsius (°C) | Fahrenheit display temperature (°F) | Fahrenheit (°F) | Celsius (°C) | Fahrenheit display temperature (°F) | Fahrenheit (°F) | Celsius (°C) |
|-------------------------------------|-----------------|--------------|-------------------------------------|-----------------|--------------|-------------------------------------|-----------------|--------------|
| 32/33                               | 32              | 0            | 55/56                               | 55.4            | 13           | 79/80                               | 78.8            | 26           |
| 34/35                               | 33.8            | 1            | 57/58                               | 57.2            | 14           | 81                                  | 80.6            | 27           |
| 36                                  | 35.6            | 2            | 59/60                               | 59              | 15           | 82/83                               | 82.4            | 28           |
| 37/38                               | 37.4            | 3            | 61/62                               | 60.8            | 16           | 84/85                               | 84.2            | 29           |
| 39/40                               | 39.2            | 4            | 63                                  | 62.6            | 17           | 86/87                               | 86              | 30           |
| 41/42                               | 41              | 5            | 64/65                               | 64.4            | 18           | 88/89                               | 87.8            | 31           |
| 43/44                               | 42.8            | 6            | 66/67                               | 66.2            | 19           | 90                                  | 89.6            | 32           |
| 45                                  | 44.6            | 7            | 68/69                               | 68              | 20           | 91/92                               | 91.4            | 33           |
| 46/47                               | 46.4            | 8            | 70/71                               | 69.8            | 21           | 93/94                               | 93.2            | 34           |
| 48/49                               | 48.2            | 9            | 72                                  | 71.6            | 22           | 95/96                               | 95              | 35           |
| 50/51                               | 50              | 10           | 73/74                               | 73.4            | 23           | 97/98                               | 96.8            | 36           |
| 52/53                               | 51.8            | 11           | 75/76                               | 75.2            | 24           | 99                                  | 98.6            | 37           |
| 54                                  | 53.6            | 12           | 77/78                               | 77              | 25           |                                     |                 |              |

### Appendix 2: Configuration of Connection Pipe

1. Standard length of connection pipe

- 5m, 7.5m, 8m.

2. Min. length of connection pipe is 3m.

3. Max. length of connection pipe and max. high difference.

4. The additional refrigerant oil and refrigerant charging required after prolonging connection pipe

- After the length of connection pipe is prolonged for 10m at the basis of standard length, you should add 5ml of refrigerant oil for each additional 5m of connection pipe.

- The calculation method of additional refrigerant charging amount (on the basis of liquid pipe):

| Cooling capacity     | Max length of connection pipe | Max height difference |
|----------------------|-------------------------------|-----------------------|
| 5000 Btu/h(1465 W)   | 15 m                          | 5 m                   |
| 7000 Btu/h(2051 W)   | 15 m                          | 5 m                   |
| 9000 Btu/h(2637 W)   | 15 m                          | 10 m                  |
| 12000 Btu/h(3516 W)  | 20 m                          | 10 m                  |
| 18000 Btu/h(5274 W)  | 25 m                          | 10 m                  |
| 24000 Btu/h(7032 W)  | 25 m                          | 10 m                  |
| 28000 Btu/h(8204 W)  | 30 m                          | 10 m                  |
| 36000 Btu/h(10548 W) | 30 m                          | 20 m                  |
| 42000 Btu/h(12306 W) | 30 m                          | 20 m                  |
| 48000 Btu/h(14064 W) | 30 m                          | 20 m                  |

- When the length of connection pipe is above 5m, add refrigerant according to the prolonged length of liquid pipe. The additional refrigerant charging amount per meter is different according to the diameter of liquid pipe. See the following sheet.

- Additional refrigerant charging amount = prolonged length of liquid pipe X additional refrigerant charging amount per meter

| Additional refrigerant charging amount for R22, R407C, R410A and R134a |                |                       |                          |
|------------------------------------------------------------------------|----------------|-----------------------|--------------------------|
| Diameter of connection pipe                                            |                | Outdoor unit throttle |                          |
| Liquid pipe(mm)                                                        | Gas pipe(mm)   | Cooling only(g/m)     | Cooling and heating(g/m) |
| Φ6                                                                     | Φ9.5 or Φ12    | 15                    | 20                       |
| Φ6 or Φ9.5                                                             | Φ16 or Φ19     | 15                    | 20                       |
| Φ12                                                                    | Φ19 or Φ22.2   | 30                    | 120                      |
| Φ16                                                                    | Φ25.4 or Φ31.8 | 60                    | 120                      |
| Φ19                                                                    | /              | 250                   | 250                      |
| Φ22.2                                                                  | /              | 350                   | 350                      |

## Appendix 3: Pipe Expanding Method

**⚠ Note:**

**Improper pipe expanding is the main cause of refrigerant leakage. Please expand the pipe according to the following steps:**

**A: Cut the pip**

- Confirm the pipe length according to the distance of indoor unit and outdoor unit.
- Cut the required pipe with pipe cutter.

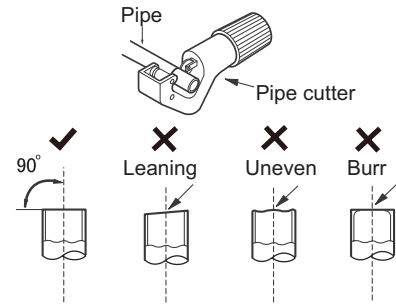

**B: Remove the burrs**

- Remove the burrs with shaper and prevent the burrs from getting into the pipe.

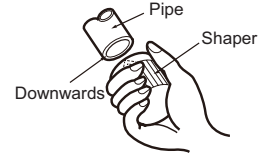

**C: Put on suitable insulating pipe**

**D: Put on the union nut**

- Remove the union nut on the indoor connection pipe and outdoor valve; install the union nut on the pipe.

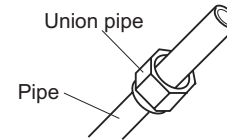

**E: Expand the port**

- Expand the port with expander.

**⚠ Note:**

- "A" is different according to the diameter, please refer to the sheet below:

| Outer diameter(mm) | A(mm) |     |
|--------------------|-------|-----|
|                    | Max   | Min |
| Φ6 - 6.35 (1/4")   | 1.3   | 0.7 |
| Φ9.52 (3/8")       | 1.6   | 1.0 |
| Φ12 - 12.70 (1/2") | 1.8   | 1.0 |
| Φ16 - 15.88 (5/8") | 2.4   | 2.2 |

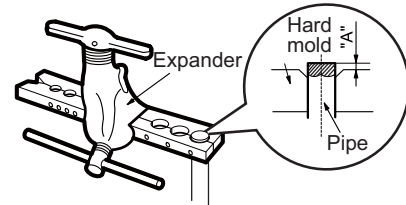

**F: Inspection**

- Check the quality of expanding port. If there is any blemish, expand the port again according to the steps above.

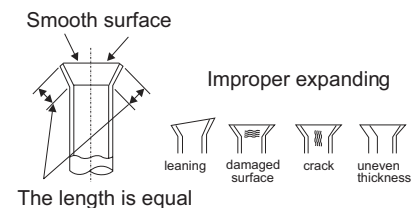

## Appendix 4: List of Resistance for Temperature Sensor

Resistance Table of Ambient Temperature Sensor for Indoor and Outdoor Units(15K)

| Temp(°C ) | Resistance(kΩ) | Temp(°C ) | Resistance(kΩ) | Temp(°C ) | Resistance(kΩ) | Temp(°C ) | Resistance(kΩ) |
|-----------|----------------|-----------|----------------|-----------|----------------|-----------|----------------|
| -19       | 138.1          | 20        | 18.75          | 59        | 3.848          | 98        | 1.071          |
| -18       | 128.6          | 21        | 17.93          | 60        | 3.711          | 99        | 1.039          |
| -17       | 121.6          | 22        | 17.14          | 61        | 3.579          | 100       | 1.009          |
| -16       | 115            | 23        | 16.39          | 62        | 3.454          | 101       | 0.98           |
| -15       | 108.7          | 24        | 15.68          | 63        | 3.333          | 102       | 0.952          |
| -14       | 102.9          | 25        | 15             | 64        | 3.217          | 103       | 0.925          |
| -13       | 97.4           | 26        | 14.36          | 65        | 3.105          | 104       | 0.898          |
| -12       | 92.22          | 27        | 13.74          | 66        | 2.998          | 105       | 0.873          |
| -11       | 87.35          | 28        | 13.16          | 67        | 2.896          | 106       | 0.848          |
| -10       | 82.75          | 29        | 12.6           | 68        | 2.797          | 107       | 0.825          |
| -9        | 78.43          | 30        | 12.07          | 69        | 2.702          | 108       | 0.802          |
| -8        | 74.35          | 31        | 11.57          | 70        | 2.611          | 109       | 0.779          |
| -7        | 70.5           | 32        | 11.09          | 71        | 2.523          | 110       | 0.758          |
| -6        | 66.88          | 33        | 10.63          | 72        | 2.439          | 111       | 0.737          |
| -5        | 63.46          | 34        | 10.2           | 73        | 2.358          | 112       | 0.717          |
| -4        | 60.23          | 35        | 9.779          | 74        | 2.28           | 113       | 0.697          |
| -3        | 57.18          | 36        | 9.382          | 75        | 2.206          | 114       | 0.678          |
| -2        | 54.31          | 37        | 9.003          | 76        | 2.133          | 115       | 0.66           |
| -1        | 51.59          | 38        | 8.642          | 77        | 2.064          | 116       | 0.642          |
| 0         | 49.02          | 39        | 8.297          | 78        | 1.997          | 117       | 0.625          |
| 1         | 46.6           | 40        | 7.967          | 79        | 1.933          | 118       | 0.608          |
| 2         | 44.31          | 41        | 7.653          | 80        | 1.871          | 119       | 0.592          |
| 3         | 42.14          | 42        | 7.352          | 81        | 1.811          | 120       | 0.577          |
| 4         | 40.09          | 43        | 7.065          | 82        | 1.754          | 121       | 0.561          |
| 5         | 38.15          | 44        | 6.791          | 83        | 1.699          | 122       | 0.547          |
| 6         | 36.32          | 45        | 6.529          | 84        | 1.645          | 123       | 0.532          |
| 7         | 34.58          | 46        | 6.278          | 85        | 1.594          | 124       | 0.519          |
| 8         | 32.94          | 47        | 6.038          | 86        | 1.544          | 125       | 0.505          |
| 9         | 31.38          | 48        | 5.809          | 87        | 1.497          | 126       | 0.492          |
| 10        | 29.9           | 49        | 5.589          | 88        | 1.451          | 127       | 0.48           |
| 11        | 28.51          | 50        | 5.379          | 89        | 1.408          | 128       | 0.467          |
| 12        | 27.18          | 51        | 5.197          | 90        | 1.363          | 129       | 0.456          |
| 13        | 25.92          | 52        | 4.986          | 91        | 1.322          | 130       | 0.444          |
| 14        | 24.73          | 53        | 4.802          | 92        | 1.282          | 131       | 0.433          |
| 15        | 23.6           | 54        | 4.625          | 93        | 1.244          | 132       | 0.422          |
| 16        | 22.53          | 55        | 4.456          | 94        | 1.207          | 133       | 0.412          |
| 17        | 21.51          | 56        | 4.294          | 95        | 1.171          | 134       | 0.401          |
| 18        | 20.54          | 57        | 4.139          | 96        | 1.136          | 135       | 0.391          |
| 19        | 19.63          | 58        | 3.99           | 97        | 1.103          | 136       | 0.382          |

Resistance Table of Tube Temperature Sensors for Indoor and Outdoor (20K)

| Temp(°C ) | Resistance(kΩ) | Temp(°C ) | Resistance(kΩ) | Temp(°C ) | Resistance(kΩ) | Temp(°C ) | Resistance(kΩ) |
|-----------|----------------|-----------|----------------|-----------|----------------|-----------|----------------|
| -19       | 181.4          | 20        | 25.01          | 59        | 5.13           | 98        | 1.427          |
| -18       | 171.4          | 21        | 23.9           | 60        | 4.948          | 99        | 1.386          |
| -17       | 162.1          | 22        | 22.85          | 61        | 4.773          | 100       | 1.346          |
| -16       | 153.3          | 23        | 21.85          | 62        | 4.605          | 101       | 1.307          |
| -15       | 145            | 24        | 20.9           | 63        | 4.443          | 102       | 1.269          |
| -14       | 137.2          | 25        | 20             | 64        | 4.289          | 103       | 1.233          |
| -13       | 129.9          | 26        | 19.14          | 65        | 4.14           | 104       | 1.198          |
| -12       | 123            | 27        | 18.13          | 66        | 3.998          | 105       | 1.164          |
| -11       | 116.5          | 28        | 17.55          | 67        | 3.861          | 106       | 1.131          |
| -10       | 110.3          | 29        | 16.8           | 68        | 3.729          | 107       | 1.099          |
| -9        | 104.6          | 30        | 16.1           | 69        | 3.603          | 108       | 1.069          |
| -8        | 99.13          | 31        | 15.43          | 70        | 3.481          | 109       | 1.039          |
| -7        | 94             | 32        | 14.79          | 71        | 3.364          | 110       | 1.01           |
| -6        | 89.17          | 33        | 14.18          | 72        | 3.252          | 111       | 0.983          |
| -5        | 84.61          | 34        | 13.59          | 73        | 3.144          | 112       | 0.956          |
| -4        | 80.31          | 35        | 13.04          | 74        | 3.04           | 113       | 0.93           |
| -3        | 76.24          | 36        | 12.51          | 75        | 2.94           | 114       | 0.904          |
| -2        | 72.41          | 37        | 12             | 76        | 2.844          | 115       | 0.88           |
| -1        | 68.79          | 38        | 11.52          | 77        | 2.752          | 116       | 0.856          |
| 0         | 65.37          | 39        | 11.06          | 78        | 2.663          | 117       | 0.833          |
| 1         | 62.13          | 40        | 10.62          | 79        | 2.577          | 118       | 0.811          |
| 2         | 59.08          | 41        | 10.2           | 80        | 2.495          | 119       | 0.777          |
| 3         | 56.19          | 42        | 9.803          | 81        | 2.415          | 120       | 0.769          |
| 4         | 53.46          | 43        | 9.42           | 82        | 2.339          | 121       | 0.746          |
| 5         | 50.87          | 44        | 9.054          | 83        | 2.265          | 122       | 0.729          |
| 6         | 48.42          | 45        | 8.705          | 84        | 2.194          | 123       | 0.71           |
| 7         | 46.11          | 46        | 8.37           | 85        | 2.125          | 124       | 0.692          |
| 8         | 43.92          | 47        | 8.051          | 86        | 2.059          | 125       | 0.674          |
| 9         | 41.84          | 48        | 7.745          | 87        | 1.996          | 126       | 0.658          |
| 10        | 39.87          | 49        | 7.453          | 88        | 1.934          | 127       | 0.64           |
| 11        | 38.01          | 50        | 7.173          | 89        | 1.875          | 128       | 0.623          |
| 12        | 36.24          | 51        | 6.905          | 90        | 1.818          | 129       | 0.607          |
| 13        | 34.57          | 52        | 6.648          | 91        | 1.736          | 130       | 0.592          |
| 14        | 32.98          | 53        | 6.403          | 92        | 1.71           | 131       | 0.577          |
| 15        | 31.47          | 54        | 6.167          | 93        | 1.658          | 132       | 0.563          |
| 16        | 30.04          | 55        | 5.942          | 94        | 1.609          | 133       | 0.549          |
| 17        | 28.68          | 56        | 5.726          | 95        | 1.561          | 134       | 0.535          |
| 18        | 27.39          | 57        | 5.519          | 96        | 1.515          | 135       | 0.521          |
| 19        | 26.17          | 58        | 5.32           | 97        | 1.47           | 136       | 0.509          |

Resistance Table of Discharge Temperature Sensor for Outdoor(50K)

| Temp(°C ) | Resistance(kΩ) | Temp(°C ) | Resistance(kΩ) | Temp(°C ) | Resistance(kΩ) | Temp(°C ) | Resistance(kΩ) |
|-----------|----------------|-----------|----------------|-----------|----------------|-----------|----------------|
| -29       | 853.5          | 10        | 98             | 49        | 18.34          | 88        | 4.754          |
| -28       | 799.8          | 11        | 93.42          | 50        | 17.65          | 89        | 4.609          |
| -27       | 750            | 12        | 89.07          | 51        | 16.99          | 90        | 4.469          |
| -26       | 703.8          | 13        | 84.95          | 52        | 16.36          | 91        | 4.334          |
| -25       | 660.8          | 14        | 81.05          | 53        | 15.75          | 92        | 4.204          |
| -24       | 620.8          | 15        | 77.35          | 54        | 15.17          | 93        | 4.079          |
| -23       | 580.6          | 16        | 73.83          | 55        | 14.62          | 94        | 3.958          |
| -22       | 548.9          | 17        | 70.5           | 56        | 14.09          | 95        | 3.841          |
| -21       | 516.6          | 18        | 67.34          | 57        | 13.58          | 96        | 3.728          |
| -20       | 486.5          | 19        | 64.33          | 58        | 13.09          | 97        | 3.619          |
| -19       | 458.3          | 20        | 61.48          | 59        | 12.62          | 98        | 3.514          |
| -18       | 432            | 21        | 58.77          | 60        | 12.17          | 99        | 3.413          |
| -17       | 407.4          | 22        | 56.19          | 61        | 11.74          | 100       | 3.315          |
| -16       | 384.5          | 23        | 53.74          | 62        | 11.32          | 101       | 3.22           |
| -15       | 362.9          | 24        | 51.41          | 63        | 10.93          | 102       | 3.129          |
| -14       | 342.8          | 25        | 49.19          | 64        | 10.54          | 103       | 3.04           |
| -13       | 323.9          | 26        | 47.08          | 65        | 10.18          | 104       | 2.955          |
| -12       | 306.2          | 27        | 45.07          | 66        | 9.827          | 105       | 2.872          |
| -11       | 289.6          | 28        | 43.16          | 67        | 9.489          | 106       | 2.792          |
| -10       | 274            | 29        | 41.34          | 68        | 9.165          | 107       | 2.715          |
| -9        | 259.3          | 30        | 39.61          | 69        | 8.854          | 108       | 2.64           |
| -8        | 245.6          | 31        | 37.96          | 70        | 8.555          | 109       | 2.568          |
| -7        | 232.6          | 32        | 36.38          | 71        | 8.268          | 110       | 2.498          |
| -6        | 220.5          | 33        | 34.88          | 72        | 7.991          | 111       | 2.431          |
| -5        | 209            | 34        | 33.45          | 73        | 7.726          | 112       | 2.365          |
| -4        | 198.3          | 35        | 32.09          | 74        | 7.47           | 113       | 2.302          |
| -3        | 199.1          | 36        | 30.79          | 75        | 7.224          | 114       | 2.241          |
| -2        | 178.5          | 37        | 29.54          | 76        | 6.998          | 115       | 2.182          |
| -1        | 169.5          | 38        | 28.36          | 77        | 6.761          | 116       | 2.124          |
| 0         | 161            | 39        | 27.23          | 78        | 6.542          | 117       | 2.069          |
| 1         | 153            | 40        | 26.15          | 79        | 6.331          | 118       | 2.015          |
| 2         | 145.4          | 41        | 25.11          | 80        | 6.129          | 119       | 1.963          |
| 3         | 138.3          | 42        | 24.13          | 81        | 5.933          | 120       | 1.912          |
| 4         | 131.5          | 43        | 23.19          | 82        | 5.746          | 121       | 1.863          |
| 5         | 125.1          | 44        | 22.29          | 83        | 5.565          | 122       | 1.816          |
| 6         | 119.1          | 45        | 21.43          | 84        | 5.39           | 123       | 1.77           |
| 7         | 113.4          | 46        | 20.6           | 85        | 5.222          | 124       | 1.725          |
| 8         | 108            | 47        | 19.81          | 86        | 5.06           | 125       | 1.682          |
| 9         | 102.8          | 48        | 19.06          | 87        | 4.904          | 126       | 1.64           |

Note: The information above is for reference only.

**PARTS GUIDE**

# MATRIX SERIE

**ASH-09AIM PT, ASH-13AIM PT**





ASH-09AIA INDOOR

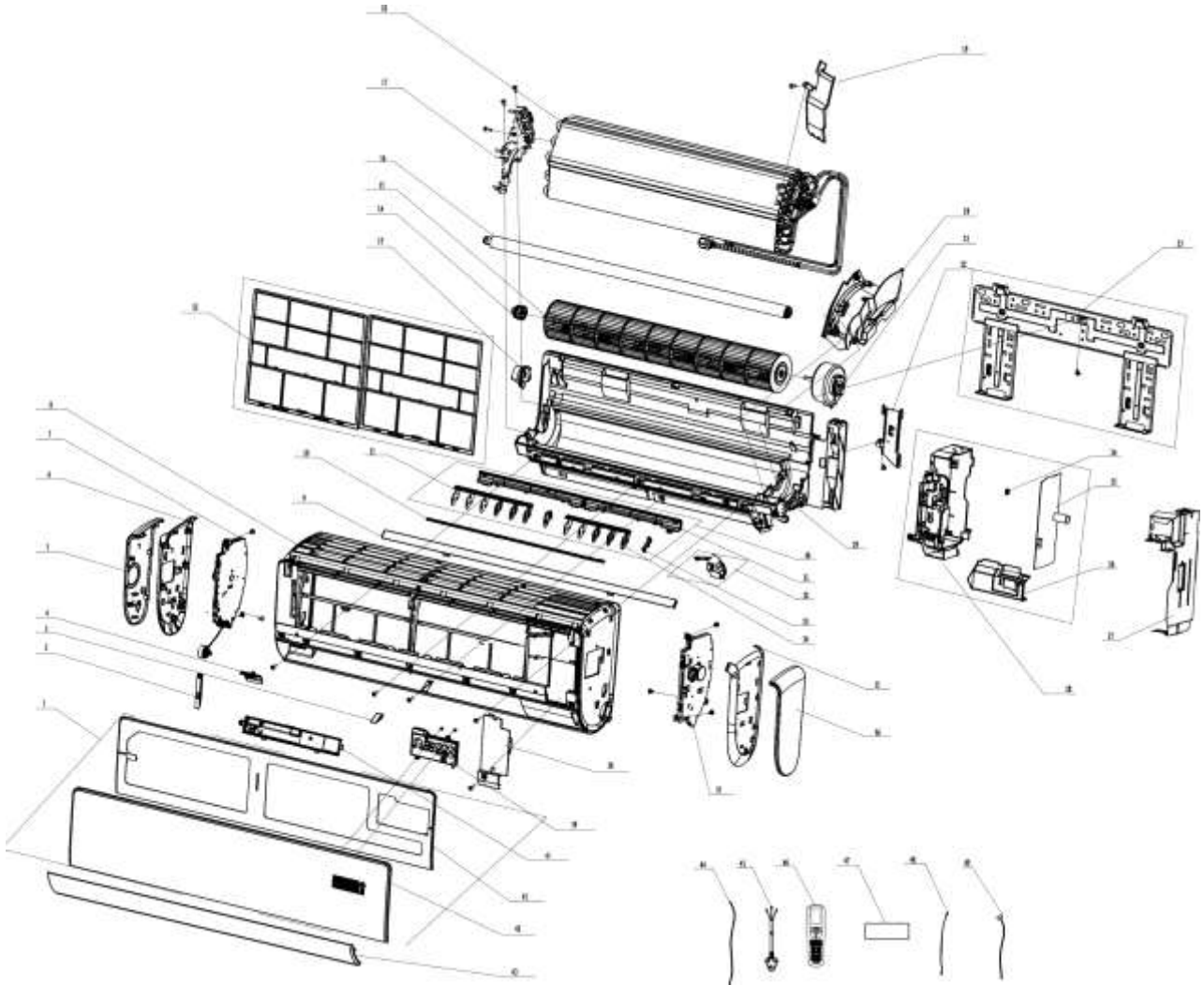

| No                           | Description                            | Part Code   | Note | Qty | Price Code |
|------------------------------|----------------------------------------|-------------|------|-----|------------|
| <b>ASH-09AIA indoor unit</b> |                                        |             |      |     |            |
| 1                            | Front Panel Sub-Assy                   | 2002264105  |      | 1   |            |
| 2                            | Stand Bar                              | 10582150P   |      | 1   |            |
| 3                            | Screw Cover                            | 24252028P   |      | 1   |            |
| 4                            | Cover Plate                            | 20122190P   |      | 1   |            |
| 5                            | Left Decorative Board                  | 20192574D03 |      | 1   |            |
| 6                            | Left Side Plate                        | 20052027P   |      | 1   |            |
| 7                            | Left Driving Box Sub-assy              | 2011218903  |      | 1   |            |
| 8                            | Front Case Assy                        | 20022470    |      | 1   |            |
| 9                            | Decorative Strip (Up)                  | 20192572D03 |      | 1   |            |
| 10                           | Swing Lever                            | 10582134    |      | 1   |            |
| 11                           | Air Louver (left)                      | 10512309    |      | 1   |            |
| 12                           | Filter Sub-Assy                        | 11122145    |      | 2   |            |
| 13                           | Ring of Bearing                        | 26152022    |      | 1   |            |
| 14                           | O-Gasket sub-assy of Bearing           | 76512056    |      | 1   |            |
| 15                           | Cross Flow Fan                         | 10352050    |      | 1   |            |
| 16                           | Drainage Hose                          | 05230014    |      | 1   |            |
| 17                           | Evaporator Support                     | 24212157    |      | 1   |            |
| 18                           | Evaporator Assy                        | 0100241702  |      | 1   |            |
| 19                           | Breakwater                             | 26112345    |      | 1   |            |
| 20                           | Motor Press Plate                      | 26112346    |      | 1   |            |
| 21                           | Fan Motor FN10Q-ZL                     | 15012140    |      | 1   |            |
| 22                           | Connecting pipe clamp                  | 2611216401  |      | 1   |            |
| 23                           | Wall Mounting Frame                    | 01252484    |      | 1   |            |
| 24                           | Jumper                                 | 4202300123  |      | 1   |            |
| 25                           | Main Board M804F2NJ                    | 30138000654 |      | 1   |            |
| 26                           | Mouseproof Board                       | 26112344    |      | 1   |            |
| 27                           | Shield Cover of Electric Box Sub-assy  | 01592126    |      | 1   |            |
| 28                           | Electric Box Assy                      | 10000201566 |      | 1   |            |
| 29                           | Rear Case assy                         | 22202289    |      | 1   |            |
| 30                           | Helicoid Tongue sub-assy               | 26112350    |      | 1   |            |
| 31                           | Helicoid Tongue                        | 26112343    |      | 1   |            |
| 32                           | Louver Motor Sub-assy (Left and Right) | 15002019    |      | 1   |            |
| 33                           | Crank 1                                | 73012026    |      | 1   |            |
| 34                           | Air Louver(right)                      | 10512718    |      | 1   |            |
| 35                           | Right Side Plate                       | 20052026P   |      | 1   |            |
| 36                           | Right Decorative Board                 | 20192573D03 |      | 1   |            |
| 37                           | Right Driving Box Sub-assy             | 2011219003  |      | 1   |            |
| 38                           | Electric Box Cover Sub-Assy            | 20122192    |      | 1   |            |
| 39                           | Display Board D8583U                   | 30568248    |      | 1   |            |
| 40                           | Detecting Plate CS532K                 | 30070049    |      | 1   |            |
| 41                           | Front Panel                            | 20022393    |      | 1   |            |
| 42                           | Front Panel                            | 2002264205  |      | 1   |            |
| 43                           | Guide Louver                           | 1051291101  |      | 1   |            |
| 44                           | Connecting Cable (4x0.75)              | 4002052317  |      | 0   |            |
| 45                           | Power Cord                             | none        |      | 0   |            |
| 46                           | Remote Controller SAA1FB1              | 30510559    |      | 1   |            |
| 47                           | Filter (antimicrobial)                 | none        |      | 0   |            |
| 48                           | Temperature Sensor 20KT-EH-2P-300mm    | 390000594   |      | 1   |            |
| 49                           | Temperature Sensor 15KS-XH-2P-K3-340mm | 390000455   |      | 1   |            |

**The data are subject to change without notice.**

ASH-09AIA OUTDOOR

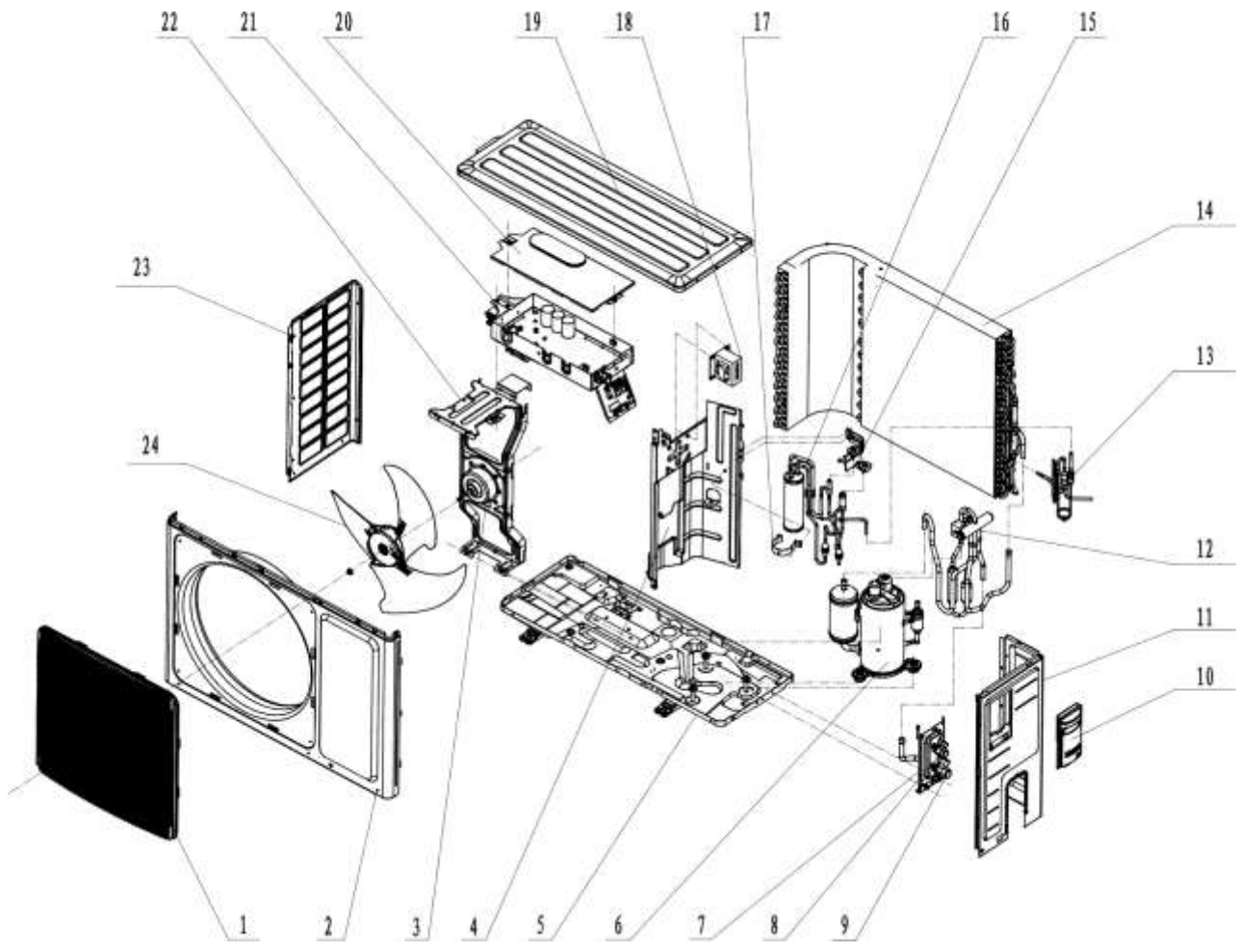

| No                            | Description                            | Part Code   | Note | Qty | Price Code |
|-------------------------------|----------------------------------------|-------------|------|-----|------------|
| <b>ASH-09AIA outdoor unit</b> |                                        |             |      |     |            |
| 1                             | Front Grill                            | 22413050    |      | 1   |            |
| 2                             | Front Panel Assy                       | 0153305106  |      | 1   |            |
| 3                             | Fan Motor FW30J-ZL                     | 1501308507  |      | 1   |            |
| 4                             | Clapboard                              | 01233510    |      | 1   |            |
| 5                             | Chassis Sub-assy                       | 0280311901P |      | 1   |            |
| 6                             | Compressor and Fittings QXAT-B121zE070 | 00103977    |      | 1   |            |
| 7                             | Valve Support Sub-Assy                 | 01703242P   |      | 1   |            |
| 8                             | Cut off Valve Sub-Assy 1/4             | 0713376301  |      | 1   |            |
| 9                             | Valve 1/2(R410A)                       | 07100006    |      | 1   |            |
| 10                            | Big Handle                             | 2623343106  |      | 1   |            |
| 11                            | Right Side Plate                       | 0130510001P |      | 1   |            |
| 12                            | 4-Way Valve Assy                       | 03073358    |      | 1   |            |
| 13                            | Capillary Sub-assy                     | 03000600300 |      | 1   |            |
| 14                            | Condenser Assy                         | 01100200314 |      | 1   |            |
| 15                            | Stationary Barrier                     | 01703179    |      | 1   |            |
| 16                            | Flash Vaporizer Sub-assy               | 07223057    |      | 1   |            |
| 17                            | Tube Clip                              | 02143030    |      | 1   |            |
| 18                            | Reactor L8mH/10A                       | 43130185    |      | 1   |            |
| 19                            | Coping                                 | 01253034P   |      | 1   |            |
| 20                            | Electric Box Cover Sub-Assy            | 0260309601  |      | 1   |            |
| 21                            | Electric Box Assy                      | 10000100252 |      | 1   |            |
| 22                            | Motor Support Sub-Assy                 | 01703180    |      | 1   |            |
| 23                            | Left Side Plate                        | 01303169P   |      | 1   |            |
| 24                            | Axial Flow Fan                         | 10333022    |      | 1   |            |

The data are subject to change without notice.

ASH-13AIA INDOOR

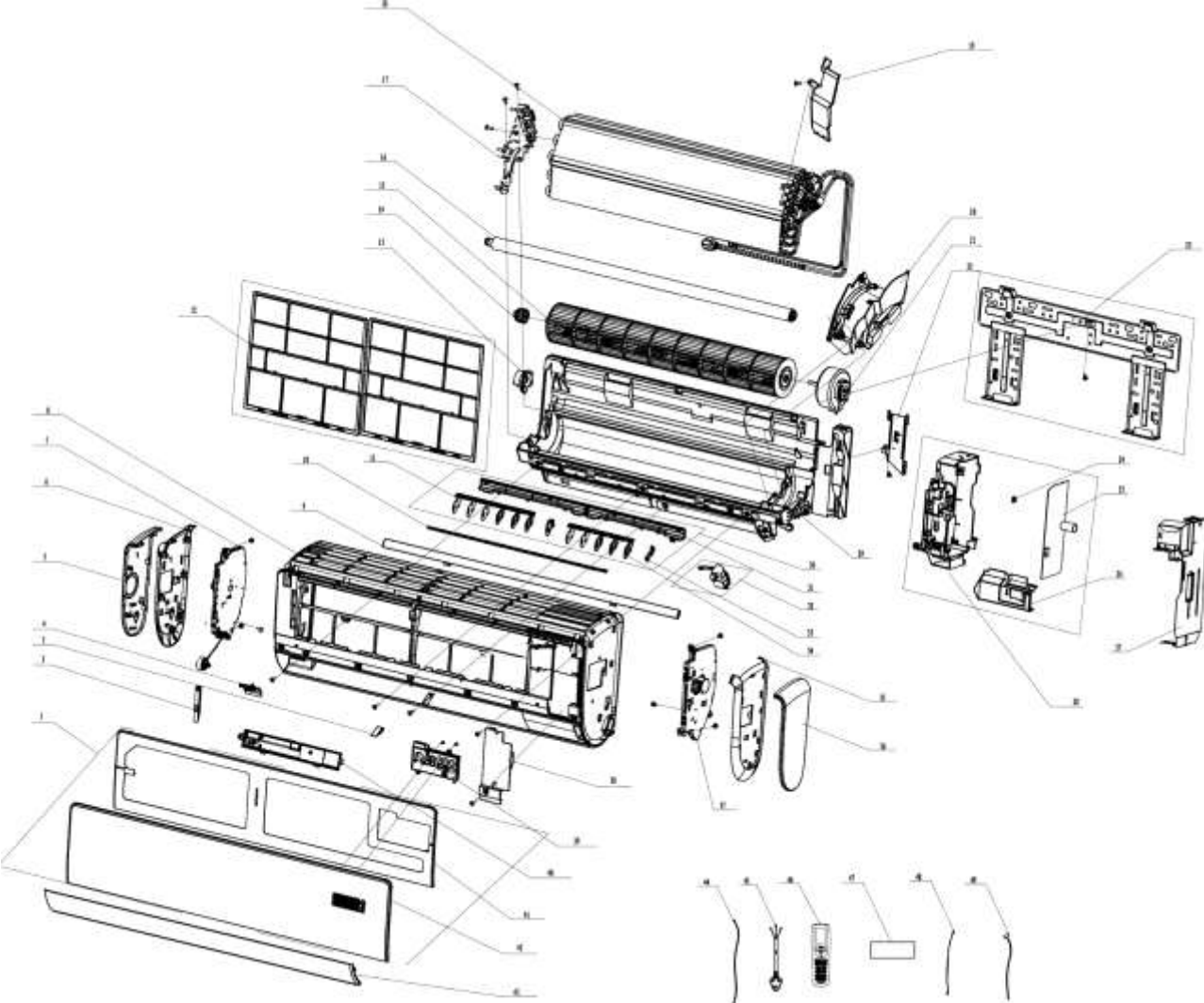

| No                           | Description                            | Part Code   | Note | Qty | Price Code |
|------------------------------|----------------------------------------|-------------|------|-----|------------|
| <b>ASH-13AIA indoor unit</b> |                                        |             |      |     |            |
| 1                            | Front Panel Sub-Assy                   | 2002264105  |      | 1   |            |
| 2                            | Stand Bar                              | 10582150P   |      | 1   |            |
| 3                            | Screw Cover                            | 24252028P   |      | 1   |            |
| 4                            | Cover Plate                            | 20122190P   |      | 1   |            |
| 5                            | Left Decorative Board                  | 20192574D03 |      | 1   |            |
| 6                            | Left Side Plate                        | 20052027P   |      | 1   |            |
| 7                            | Left Driving Box Sub-assy              | 2011218903  |      | 1   |            |
| 8                            | Front Case Assy                        | 20022470    |      | 1   |            |
| 9                            | Decorative Strip (Up)                  | 20192572D03 |      | 1   |            |
| 10                           | Swing Lever                            | 10582134    |      | 1   |            |
| 11                           | Air Louver (left)                      | 10512309    |      | 1   |            |
| 12                           | Filter Sub-Assy                        | 11122145    |      | 2   |            |
| 13                           | Ring of Bearing                        | 26152022    |      | 1   |            |
| 14                           | O-Gasket sub-assy of Bearing           | 76512056    |      | 1   |            |
| 15                           | Cross Flow Fan                         | 10352050    |      | 1   |            |
| 16                           | Drainage Hose                          | 05230014    |      | 1   |            |
| 17                           | Evaporator Support                     | 24212157    |      | 1   |            |
| 18                           | Evaporator Assy                        | 0100241702  |      | 1   |            |
| 19                           | Breakwater                             | 26112345    |      | 1   |            |
| 20                           | Motor Press Plate                      | 26112346    |      | 1   |            |
| 21                           | Fan Motor FN10Q-ZL                     | 15012140    |      | 1   |            |
| 22                           | Connecting pipe clamp                  | 2611216401  |      | 1   |            |
| 23                           | Wall Mounting Frame                    | 01252484    |      | 1   |            |
| 24                           | Jumper                                 | 4202300124  |      | 1   |            |
| 25                           | Main Board M804F2NJ                    | 30138000654 |      | 1   |            |
| 26                           | Mouseproof Board                       | 26112344    |      | 1   |            |
| 27                           | Shield Cover of Electric Box Sub-assy  | 01592126    |      | 1   |            |
| 28                           | Electric Box Assy                      | 10000201567 |      | 1   |            |
| 29                           | Rear Case assy                         | 22202289    |      | 1   |            |
| 30                           | Helicoid Tongue sub-assy               | 26112350    |      | 1   |            |
| 31                           | Helicoid Tongue                        | 26112343    |      | 1   |            |
| 32                           | Louver Motor Sub-assy (Left and Right) | 15002019    |      | 1   |            |
| 33                           | Crank 1                                | 73012026    |      | 1   |            |
| 34                           | Air Louver(right)                      | 10512718    |      | 1   |            |
| 35                           | Right Side Plate                       | 20052026P   |      | 1   |            |
| 36                           | Right Decorative Board                 | 20192573D03 |      | 1   |            |
| 37                           | Right Driving Box Sub-assy             | 2011219003  |      | 1   |            |
| 38                           | Electric Box Cover Sub-Assy            | 20122192    |      | 1   |            |
| 39                           | Display Board D8583U                   | 30568248    |      | 1   |            |
| 40                           | Detecting Plate CS532K                 | 30070049    |      | 1   |            |
| 41                           | Front Panel                            | 20022393    |      | 1   |            |
| 42                           | Front Panel                            | 2002264205  |      | 1   |            |
| 43                           | Guide Louver                           | 1051291101  |      | 1   |            |
| 44                           | Connecting Cable (4x0.75)              | 4002052317  |      | 0   |            |
| 45                           | Power Cord                             | none        |      | 0   |            |
| 46                           | Remote Controller SAA1FB1              | 30510559    |      | 1   |            |
| 47                           | Filter (antimicrobial)                 | none        |      | 0   |            |
| 48                           | Temperature Sensor 20KT-EH-2P-300mm    | 390000594   |      | 1   |            |
| 49                           | Temperature Sensor 15KS-XH-2P-K3-340mm | 390000455   |      | 1   |            |

**The data are subject to change without notice.**

ASH-13A1A OUTDOOR

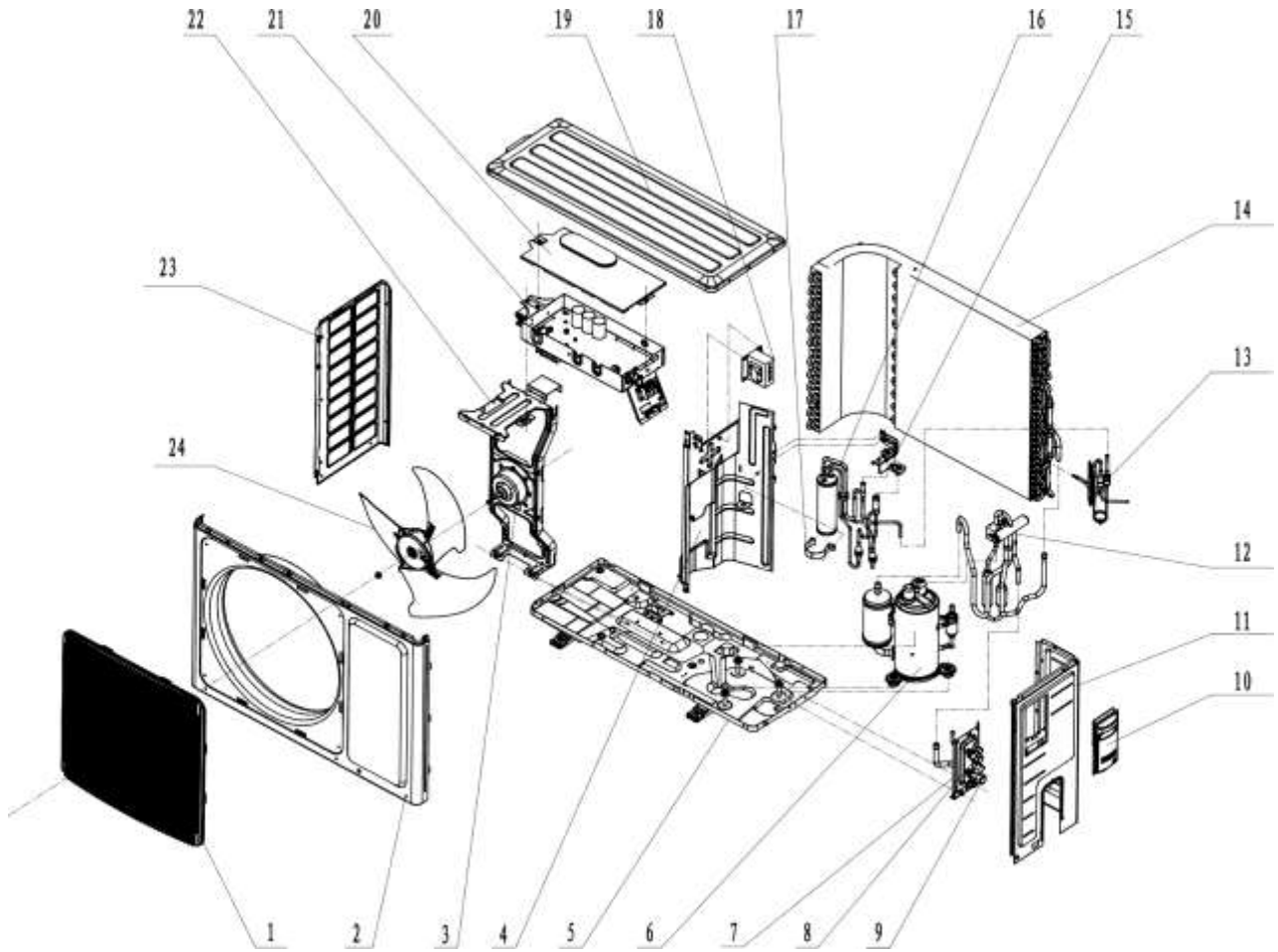

| No                            | Description                            | Part Code   | Note | Qty | Price Code |
|-------------------------------|----------------------------------------|-------------|------|-----|------------|
| <b>ASH-13AIA outdoor unit</b> |                                        |             |      |     |            |
| 1                             | Front Grill                            | 22413050    |      | 1   |            |
| 2                             | Front Panel Assy                       | 0153305106  |      | 1   |            |
| 3                             | Fan Motor FW30J-ZL                     | 1501308507  |      | 1   |            |
| 4                             | Clapboard                              | 01233510    |      | 1   |            |
| 5                             | Chassis Sub-assy                       | 0280311901P |      | 1   |            |
| 6                             | Compressor and Fittings QXAT-B121zE070 | 00103977    |      | 1   |            |
| 7                             | Valve Support Sub-Assy                 | 01703242P   |      | 1   |            |
| 8                             | Cut off Valve Sub-Assy 1/4             | 0713376301  |      | 1   |            |
| 9                             | Valve 1/2(R410A)                       | 07100006    |      | 1   |            |
| 10                            | Big Handle                             | 2623343106  |      | 1   |            |
| 11                            | Right Side Plate                       | 0130510001P |      | 1   |            |
| 12                            | 4-Way Valve Assy                       | 03073358    |      | 1   |            |
| 13                            | Capillary Sub-assy                     | 03000600300 |      | 1   |            |
| 14                            | Condenser Assy                         | 01100200314 |      | 1   |            |
| 15                            | Stationary Barrier                     | 01703179    |      | 1   |            |
| 16                            | Flash Vaporizer Sub-assy               | 07223057    |      | 1   |            |
| 17                            | Tube Clip                              | 02143030    |      | 1   |            |
| 18                            | Reactor L8mH/10A                       | 43130185    |      | 1   |            |
| 19                            | Coping                                 | 01253034P   |      | 1   |            |
| 20                            | Electric Box Cover Sub-Assy            | 0260309601  |      | 1   |            |
| 21                            | Electric Box Assy                      | 10000100256 |      | 1   |            |
| 22                            | Motor Support Sub-Assy                 | 01703180    |      | 1   |            |
| 23                            | Left Side Plate                        | 01303169P   |      | 1   |            |
| 24                            | Axial Flow Fan                         | 10333022    |      | 1   |            |

The data are subject to change without notice.

ASH-18AIA INDOOR

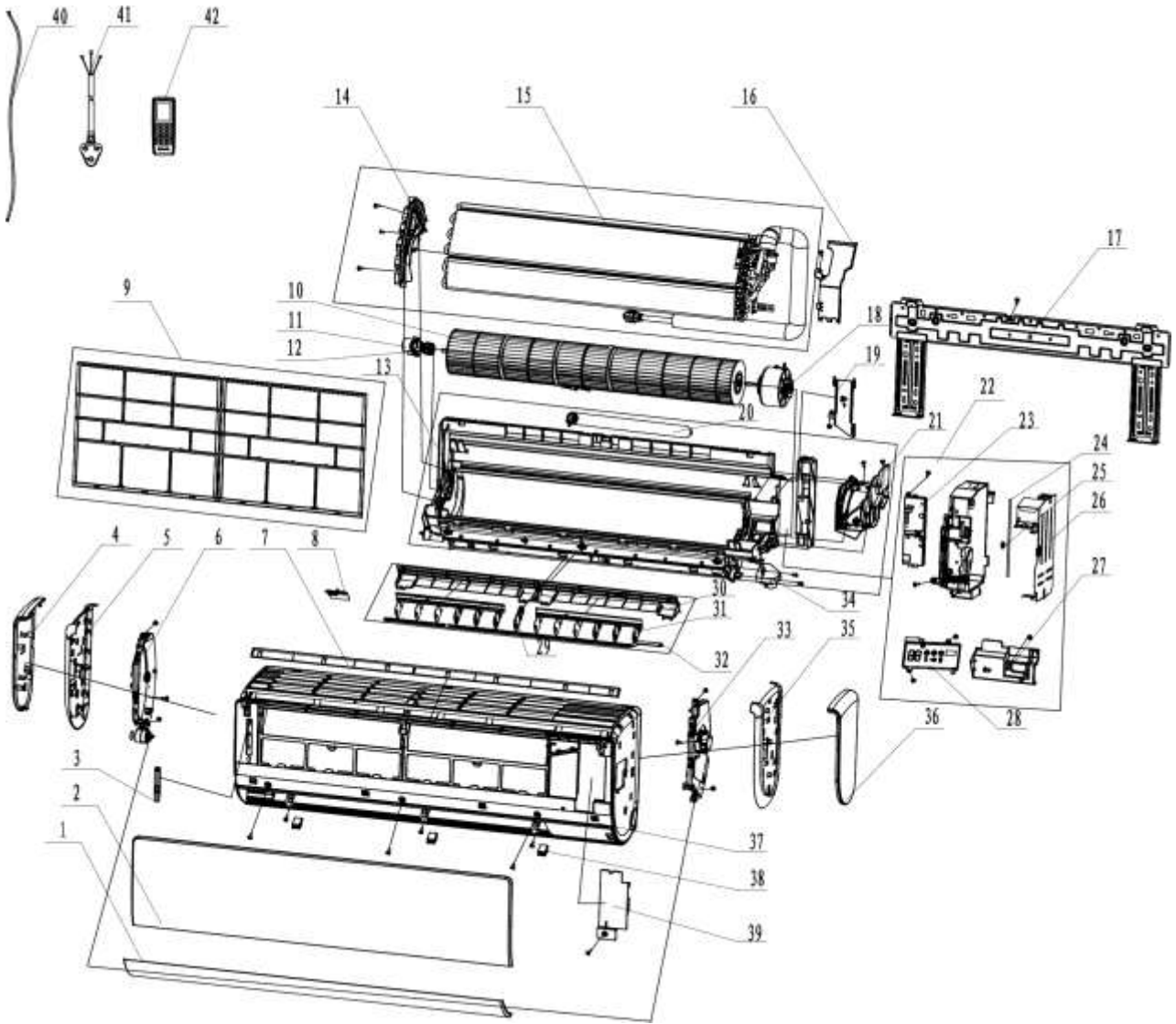

| No                           | Description                            | Part Code   | Note | Qty | Price Code |
|------------------------------|----------------------------------------|-------------|------|-----|------------|
| <b>ASH-18AIA indoor unit</b> |                                        |             |      |     |            |
| 1                            | Guide Louver                           | 10512916    |      | 1   |            |
| 2                            | Front Panel                            | 2002240902  |      | 1   |            |
| 3                            | Stand Bar                              | 10582150P   |      | 1   |            |
| 4                            | Left Side Plate                        | 26112361P   |      | 1   |            |
| 5                            | Left Decorative Board                  | 20192600    |      | 1   |            |
| 6                            | Left Driving Box Sub-assy              | 2011220101  |      | 1   |            |
| 7                            | Decorative Strip (Up)                  | 20192602    |      | 1   |            |
| 8                            | Cover plate(Air Outlet)                | 20122193P   |      | 1   |            |
| 9                            | Filter Sub-Assy                        | 11122155    |      | 2   |            |
| 10                           | Cross Flow Fan                         | 10352054    |      | 1   |            |
| 11                           | Ring of Bearing                        | 26152022    |      | 1   |            |
| 12                           | O-Gasket sub-assy of Bearing           | 7651205102  |      | 1   |            |
| 13                           | Rear Case assy                         | 22202298    |      | 1   |            |
| 14                           | Evaporator Support                     | 24212170    |      | 1   |            |
| 15                           | Evaporator Assy                        | 01100100177 |      | 1   |            |
| 16                           | Breakwater                             | 26112359    |      | 1   |            |
| 17                           | Wall Mounting Frame                    | 01252040    |      | 1   |            |
| 18                           | Fan Motor FN20V-ZL                     | 15012466    |      | 1   |            |
| 19                           | Connecting pipe clamp                  | 2611216401  |      | 1   |            |
| 20                           | Drainage Hose                          | 05230014    |      | 1   |            |
| 21                           | Motor Press Plate                      | 26112360    |      | 1   |            |
| 22                           | Electric Box Assy                      | 10000201564 |      | 1   |            |
| 23                           | Detecting Plate CS532K                 | 30070049    |      | 1   |            |
| 24                           | Main Board M804F2PJ                    | 30138000653 |      | 1   |            |
| 25                           | Jumper                                 | 4202021918  |      | 1   |            |
| 26                           | Shield Cover of Electric Box Sub-assy  | 01592131    |      | 1   |            |
| 27                           | Mouseproof Board                       | 26112358    |      | 1   |            |
| 28                           | Display Board D8583S                   | 30568247    |      | 1   |            |
| 29                           | Air Louver (Middle)                    | 1051291701  |      | 1   |            |
| 30                           | Helicoid Tongue sub-assy               | 2611236602  |      | 1   |            |
| 31                           | Air Louver                             | 1051229202  |      | 2   |            |
| 32                           | Swing Lever                            | 1058214702  |      | 1   |            |
| 33                           | Right Driving Box Sub-assy             | 2011220001  |      | 1   |            |
| 34                           | Louver Motor Sub-assy (Left and Right) | 15002021    |      | 1   |            |
| 35                           | Right Decorative Board                 | 20192601    |      | 1   |            |
| 36                           | Right Side Plate                       | 26112362P   |      | 1   |            |
| 37                           | Front Case Assy                        | 00000200048 |      | 1   |            |
| 38                           | Screw Cover                            | 24252029P   |      | 3   |            |
| 39                           | Electric Box Cover Sub-Assy            | 2012219701  |      | 1   |            |
| 40                           | Connecting Cable 4x0.75                | 4002052317  |      | 0   |            |
| 41                           | Power Cord                             | none        |      | 0   |            |
| 42                           | Remote Controller SAA1FB1              | 30510559    |      | 1   |            |

The data are subject to change without notice.

ASH-18AIA OUTDOOR

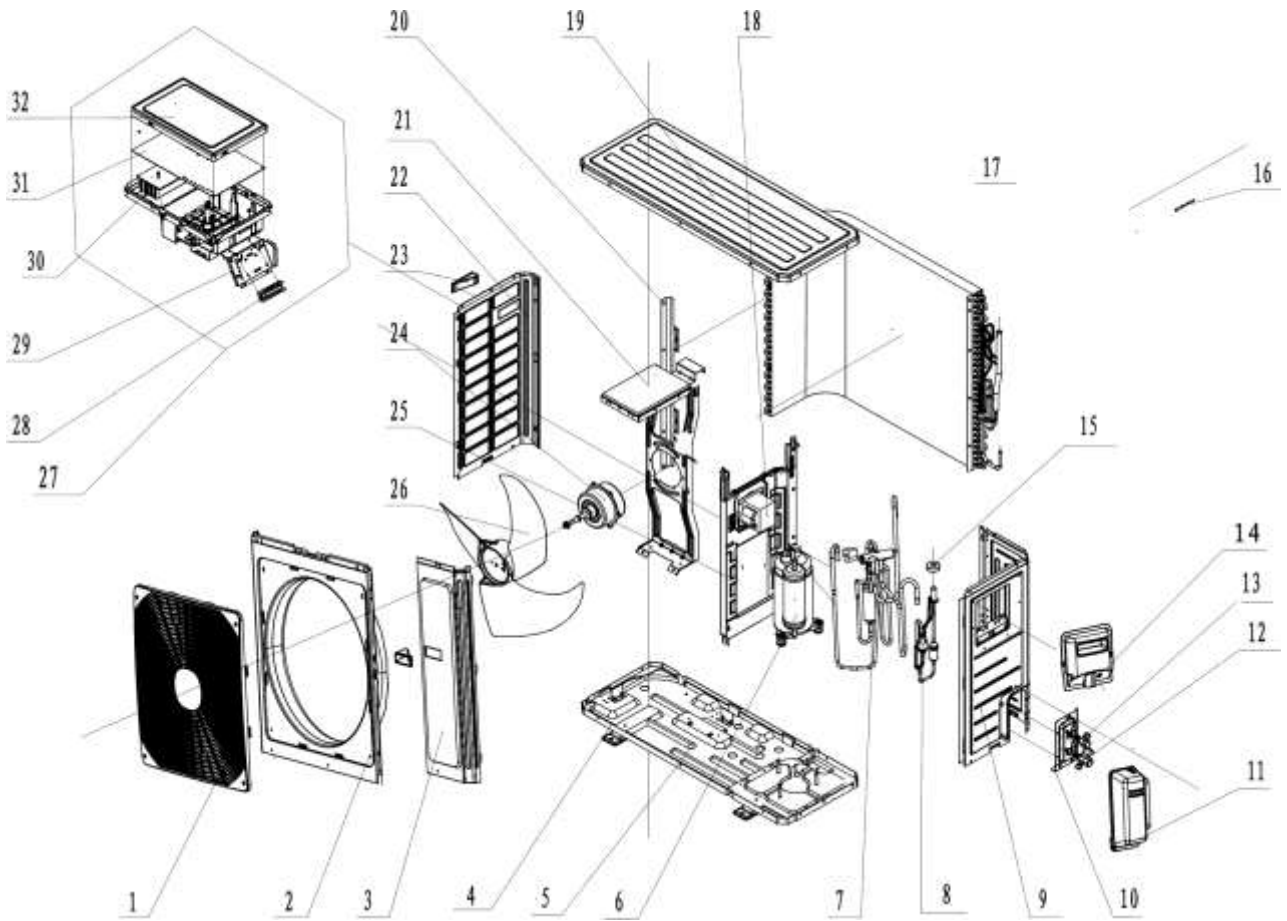

| No                            | Description                                                      | Part Code    | Note | Qty | Price Code |
|-------------------------------|------------------------------------------------------------------|--------------|------|-----|------------|
| <b>ASH-18AIA outdoor unit</b> |                                                                  |              |      |     |            |
| 1                             | Front Grill                                                      | 22415010     |      | 1   |            |
| 2                             | Front Panel Assy                                                 | 01533058     |      | 1   |            |
| 3                             | Front Side Plate Sub-Assy                                        | none         |      | 0   |            |
| 4                             | Chassis Sub-assy                                                 | 01700000016P |      | 1   |            |
| 5                             | Electrical Heater (Chassis)                                      | 7651000411   |      | 1   |            |
| 6                             | Compressor and Fittings QXAT-B121zF070                           | 00105260     |      | 1   |            |
| 7                             | 4-Way Valve Assy                                                 | 0302552701   |      | 1   |            |
| 8                             | Electronic Expansion Valve assy                                  | 0713522201   |      | 1   |            |
| 9                             | Right Side Plate Assy                                            | 0130329201   |      | 1   |            |
| 10                            | Valve Support Sub-Assy                                           | 01705066P    |      | 1   |            |
| 11                            | Valve Cover                                                      | 22245002     |      | 1   |            |
| 12                            | Cut off Valve 1/2(N)                                             | 071302392    |      | 1   |            |
| 13                            | Cut off Valve 1/4(N)                                             | 07130239     |      | 1   |            |
| 14                            | Big Handle                                                       | none         |      | 0   |            |
| 15                            | Magnet Coil                                                      | 4304000415   |      | 1   |            |
| 16                            | Temperature Sensor<br>20KT/15KS/50KT-JST-XARP-06V-1200/800/600mm | 3900030901   |      | 1   |            |
| 17                            | Condenser Assy                                                   | 0110573501   |      | 1   |            |
| 18                            | Reactor 3.5mH/16A                                                | 43130186     |      | 1   |            |
| 19                            | Coping                                                           | 01255005P    |      | 1   |            |
| 20                            | Supporting Board(Condenser)                                      | 01795010     |      | 1   |            |
| 21                            | Motor Support Sub-Assy                                           | 01705036     |      | 1   |            |
| 22                            | Left Side Plate                                                  | 01305093P    |      | 1   |            |
| 23                            | Left Handle                                                      | none         |      | 0   |            |
| 24                            | Fan Motor LW60M-ZL                                               | 1501506402   |      | 1   |            |
| 25                            | Clapboard Sub-Assy                                               | 01235088     |      | 1   |            |
| 26                            | Axial Flow Fan                                                   | 10335008     |      | 1   |            |
| 27                            | Electric Box Assy                                                | 10000100254  |      | 1   |            |
| 28                            | Terminal Board                                                   | 420101943    |      | 1   |            |
| 29                            | Terminal Board Support sub-assy                                  | 01713120A    |      | 1   |            |
| 30                            | Radiator SRX01D99                                                | 49015215     |      | 1   |            |
| 31                            | Main Board W8732A                                                | 30138000648  |      | 1   |            |
| 32                            | Electric Box Cover                                               | 20125002     |      | 1   |            |

The data are subject to change without notice.