

Ver. | - - -



IMPORTANT NOTE:

Read this manual carefully before installing or operating your new air conditioning unit. Make sure to save this manual for future reference.

Table of Contents

Part I : Technical Information	1
1. Summary	1
2. Specifications	2
2.1 Specification Sheet.....	2
2.2 Capacity Curve in Different Outdoor Temperature.....	4
2.3 Cooling Data Sheet in Rated Frequency.....	4
2.4 Noise Curve.....	5
3. Outline Dimension Diagram	6
3.1 Indoor Unit.....	6
3.2 Outdoor Unit.....	7
4. Refrigerant System Diagram	8
5. Electrical Part	8
5.1 Wiring Diagram.....	8
5.2 PCB Printed Diagram.....	10
6. Function and Control	12
6.1 Function Buttons of Air Conditioner.....	12
6.2 Remote Control Operations.....	14
6.3 Description of Each Control Operation.....	18
6.4 Ewpe Smart App Operation Manual.....	20
Part II : Installation and Maintenance	21
7. Notes for Installation and Maintenance	21
8. Installation	25
8.1 Installation Dimension Diagram.....	25
8.2 Installation Parts-checking.....	27
8.3 Selection of Installation Location.....	27
8.4 Requirements for electric connection.....	27

8.5 Installation of Indoor Unit.....	27
8.6 Installation of Outdoor Unit.....	29
8.7 Vacuum Pumping and Leak Detection.....	31
8.8 Check after Installation and Test Operation	31
9. Troubleshooting.....	32
9.1 Judgement by Flashing LED of Indoor.....	32
9.2 How to Check Simply the Main Part of Indoor	35
9.3 How to Check Simply the Main Part of Outdoor	45
9.4 Maintenance Method for Normal Malfunction.....	47
10. Exploded View and Parts List	49
10.1 Indoor Unit.....	49
10.2 Outdoor Unit	51
11. Removal Procedure	53
11.1 Removal Procedure of Indoor Unit	53
11.2 Removal Procedure of Outdoor Unit.....	61
Appendix:	65
Appendix 1: Reference Sheet of Celsius and Fahrenheit.....	65
Appendix 2: Configuration of Connection Pipe	65
Appendix 3: Pipe Expanding Method.....	66
Appendix 4: List of Resistance for Temperature Sensor.....	67

Part I : Technical Information

1. Summary

Indoor Unit:

AST-48BI

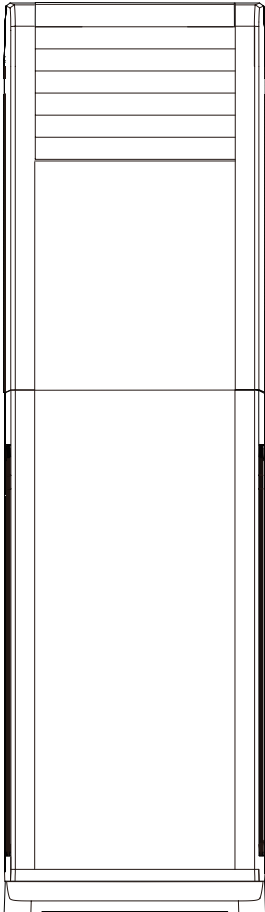

Outdoor Unit:

AST-48BI

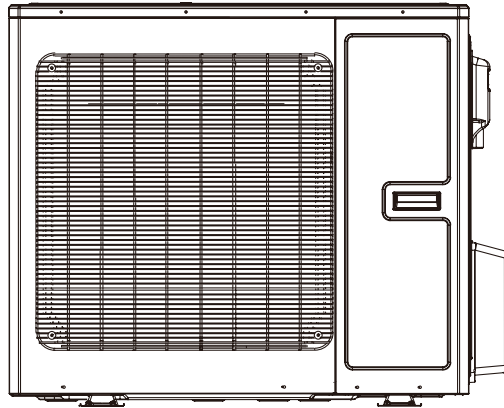

Remote Controller:

YAP1F4(WiFi)



2. Specifications

2.1 Specification Sheet

Parameter		Unit	Value
Model			AST-48BI
Power Supply	Rated Voltage	V~	220-240
	Rated Frequency	Hz	50
	Phases		1
Power Supply Mode			outdoor
Cooling Capacity		W	12500
Heating Capacity		W	13500
Cooling Power Input		W	4200
Heating Power Input		W	4200
Cooling Power Current		A	19
Heating Power Current		A	19
Rated Input		W	5400
Rated Current		A	22
Air Flow Volume(SH/H/M/L/SL)		m ³ /h	2000/1850/1700/1580/-
Dehumidifying Volume		L/h	5
EER		W/W	2.98
COP		W/W	3.21
SEER		W/W	5.6
SCOP		W/W	3.7
Application Area		m ²	55-85
Indoor Unit	Model of indoor unit		AST-48BI/I
	Fan Type		Centrifugal
	Diameter Length(DXL)	mm	Φ379X180.5
	Fan Motor Cooling Speed(SH/H/M/L/SL)	r/min	600/560/530/500/-
	Fan Motor Heating Speed(SH/H/M/L/SL)	r/min	600/560/530/500/-
	Output of Fan Motor	W	220
	Fan Motor RLA	A	/
	Fan Motor Capacitor	μF	/
	Evaporator Form		Aluminum Fin-copper Tube
	Pipe Diameter	mm	Φ7
	Row-fin Gap	mm	2-1.4
	Coil Length (LXDXW)	mm	876X25.4X472
	Swing Motor Model		MP35AB/MP24TA
	Output of Swing Motor	W	2.5/1.5
	Fuse	A	5
	Sound Pressure Level (SH/H/M/L/SL)	dB (A)	53/51/50/48/-
	Sound Power Level (SH/H/M/L/SL)	dB (A)	66/-/-/-
	Dimension (WXHDX)	mm	587X1882X394
	Dimension of Carton Box (LXWXH)	mm	2150X735X530
	Dimension of Package(LXWXH)	mm	2153X738X545
Net Weight	kg	55	
Gross Weight	kg	77.5	

Outdoor Unit	Model of Outdoor Unit		AST-48BI/O
	Compressor Manufacturer/Trademark		ZHUHAI LANDA COMPRESSOR CO., LTD
	Compressor Model		QXFS-F428zX450E
	Compressor Oil		FW68DA or equivalent
	Compressor Type		Rotary
	L.R.A.	A	38
	Compressor RLA	A	21
	Compressor Power Input	W	4580
	Overload Protector		/
	Throttling Method		Electron expansion valve
	Operation Temp	°C	16~30
	Ambient Temp (Cooling)	°C	-15~43
	Ambient Temp (Heating)	°C	-15~24
	Condenser Form		Aluminum Fin-copper Tube
	Pipe Diameter	mm	Φ7
	Rows-fin Gap	mm	2-1.4
	Coil Length (LXD _X W)	mm	1052X38X792
	Fan Motor Speed	rpm	880
	Output of Fan Motor	W	150
	Fan Motor RLA	A	0.95
	Fan Motor Capacitor	μF	/
	Air Flow Volume of Outdoor Unit	m ³ /h	6000
	Fan Type		Axial-flow
	Fan Diameter	mm	Φ550
	Defrosting Method		Automatic Defrosting
	Climate Type		T1
	Isolation		I
	Moisture Protection		IPX4
	Permissible Excessive Operating Pressure for the Discharge Side	MPa	4.3
	Permissible Excessive Operating Pressure for the Suction Side	MPa	2.5
Sound Pressure Level (H/M/L)	dB (A)	64/-/-	
Sound Power Level (H/M/L)	dB (A)	74/-/-	
Dimension (WXHXD)	mm	1028X822X530	
Dimension of Carton Box (LXWXH)	mm	1070X560X853	
Dimension of Package(LXWXH)	mm	1083X573X973	
Net Weight	kg	89	
Gross Weight	kg	100	
Refrigerant		R32	
Refrigerant Charge	kg	2.6	
Connection Pipe	Length	m	5
	Gas Additional Charge	g/m	40
	Outer Diameter Liquid Pipe		3/8
	Outer Diameter Gas Pipe		5/8
	Max Distance Height	m	20
	Max Distance Length	m	30
Note: The connection pipe applies metric diameter.			

The above data is subject to change without notice; please refer to the nameplate of the unit.

2.2 Capacity Curve in Different Outdoor Temperature

Cooling

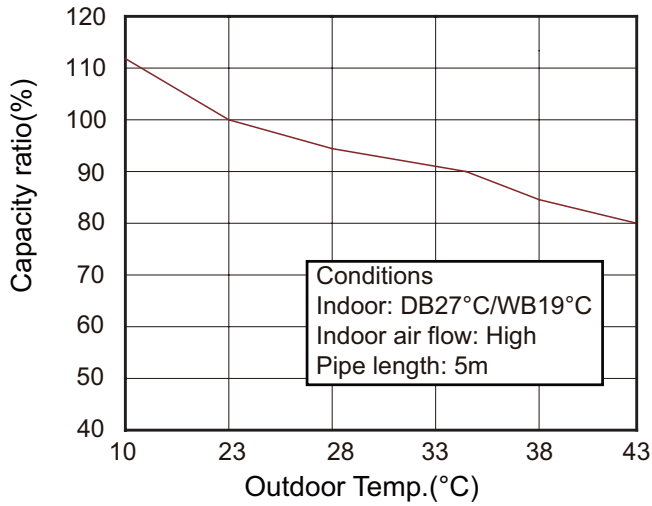

Heating

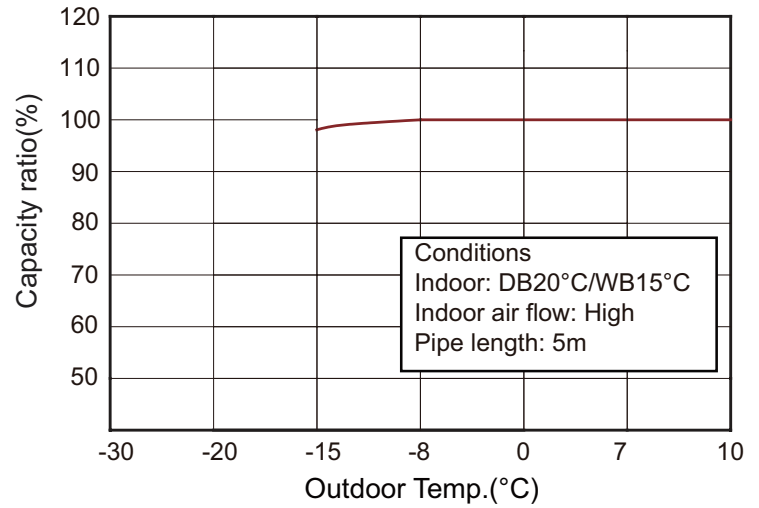

2.3 Cooling Data Sheet in Rated Frequency

Cooling:

Rated cooling condition(°C) (DB/WB)		Model	Pressure of gas pipe connecting indoor and outdoor unit	Inlet and outlet pipe temperature of heat exchanger		Fan speed of indoor unit	Fan speed of outdoor unit	Compressor frequency (Hz)
Indoor	Outdoor			T1 (°C)	T2 (°C)			
27/19	35/24	48K	0.9 to 1.1	in:8~11 out:11~14	in:75~85 out:37~43	Super High	High	48

Heating:

Rated cooling condition(°C) (DB/WB)		Model	Pressure of gas pipe connecting indoor and outdoor unit	Inlet and outlet pipe temperature of heat exchanger		Fan speed of indoor unit	Fan speed of outdoor unit	Compressor frequency (Hz)
Indoor	Outdoor			T1 (°C)	T2 (°C)			
20/-	7/6	48K	2.5 to 3.0	in:75~85 out:37~43	in:1~3 out:3~5	Super High	High	68

Instruction:

T1: Inlet and outlet pipe temperature of evaporator

T2: Inlet and outlet pipe temperature of condenser

P: Pressure at the side of big valve

Connection pipe length: 5 m.

3. Outline Dimension Diagram

3.1 Indoor Unit

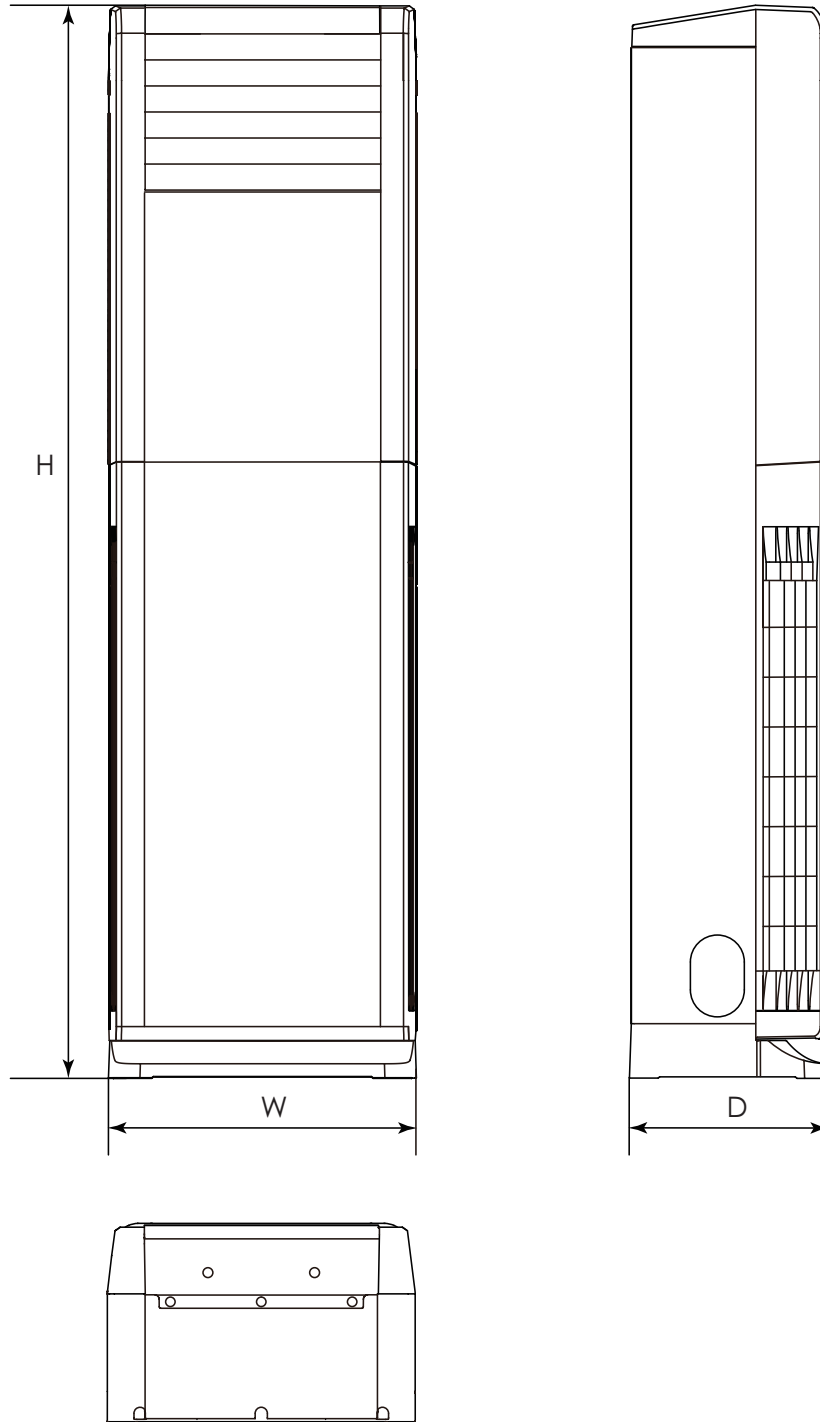

Unit:mm

Model	W	H	D
48K	587	1882	394

4. Refrigerant System Diagram

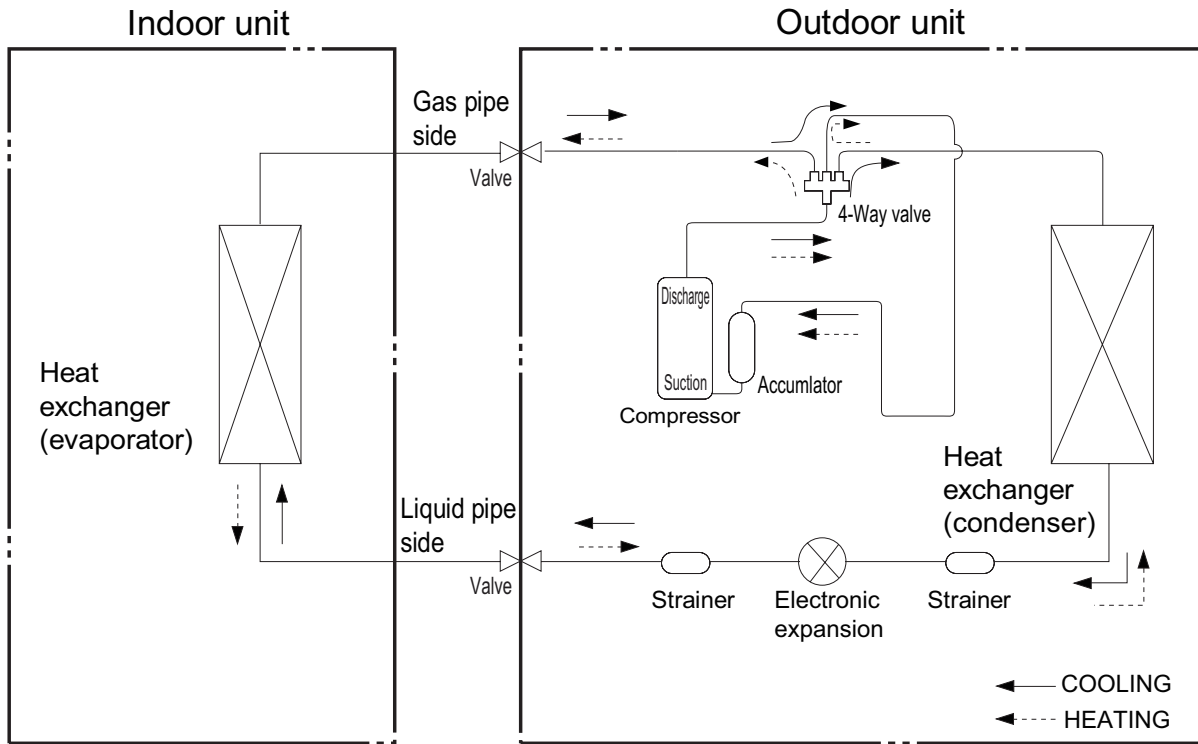

Connection pipe specification:
 Liquid : 3/8" (9.52 mm)
 Gas : 5/8" (16mm)

5. Electrical Part

5.1 Wiring Diagram

- Instruction

Symbol	Symbol Color	Symbol	Symbol Color	Symbol	Name
YE	Yellow	BN	Brown	COMP	Compressor
RD	Red	BU	Blue	⊕	Grounding wire
YEGN	Yellow/Green	BK	Black	/	/

5.2 PCB Printed Diagram

Indoor unit

• Top view

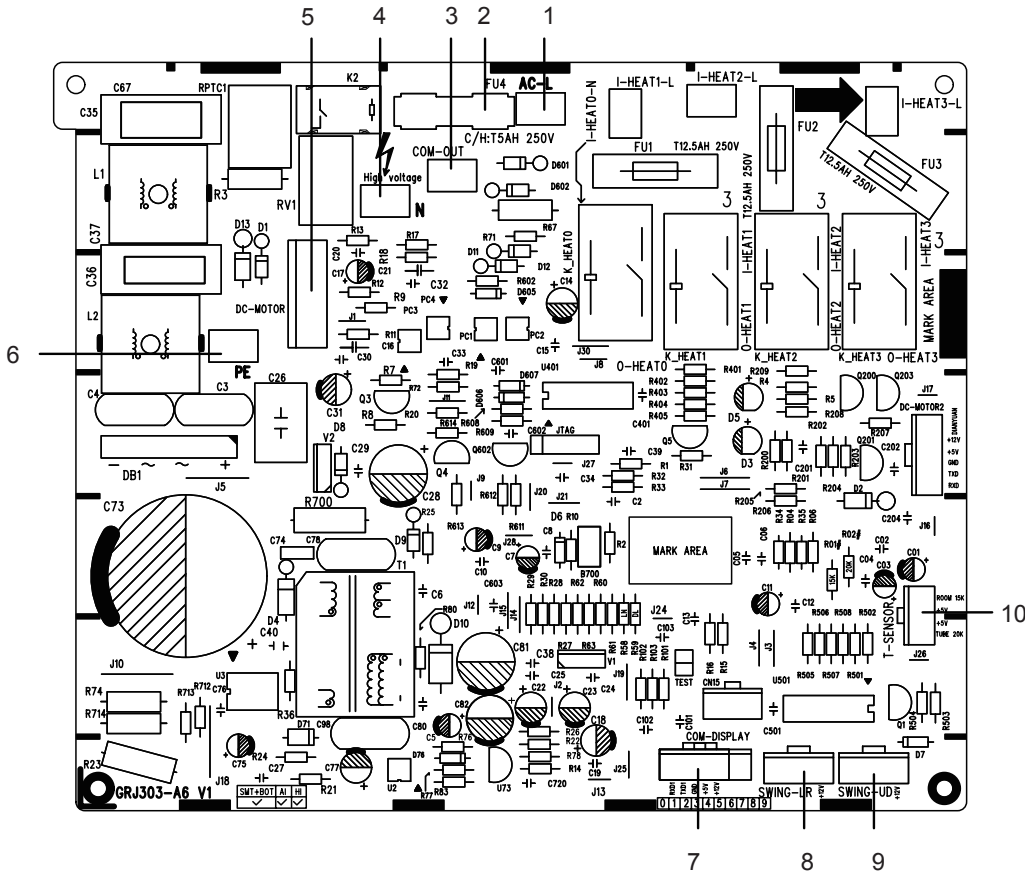

1	Interface of live wire
2	Fuse
3	Interface of communication wire for outdoor unit
4	Interface of neutral wire
5	Motor interface of indoor unit
6	Interface of earthing wire
7	Connection needle stand of display board
8	Left&right swing interface
9	Up&down swing interface
10	Needle stand of temperature sensor

• Bottom view

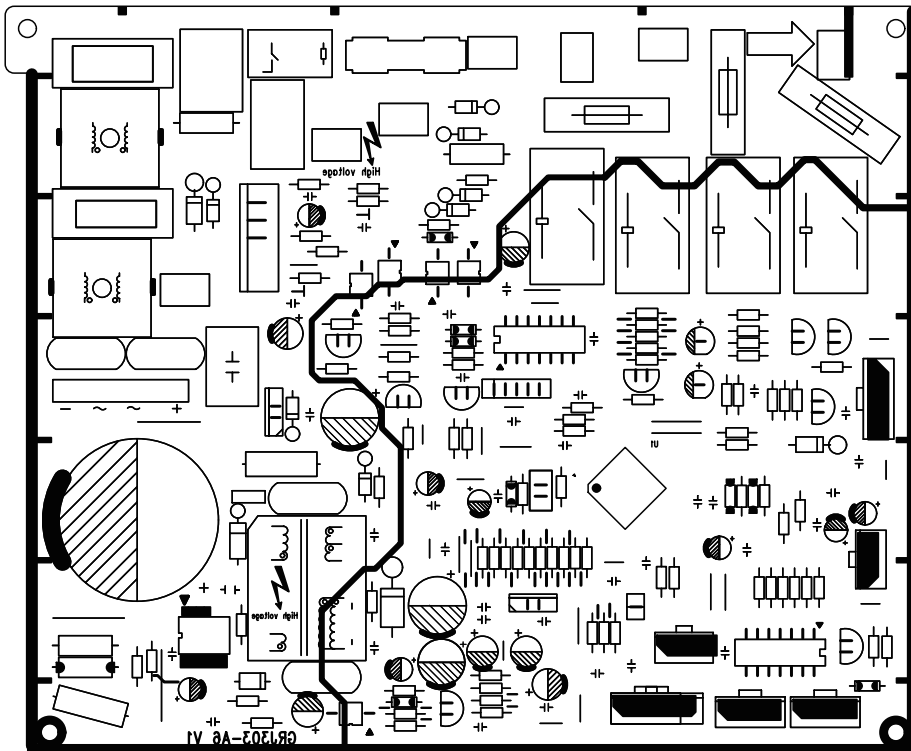

Outdoor unit

• Top view

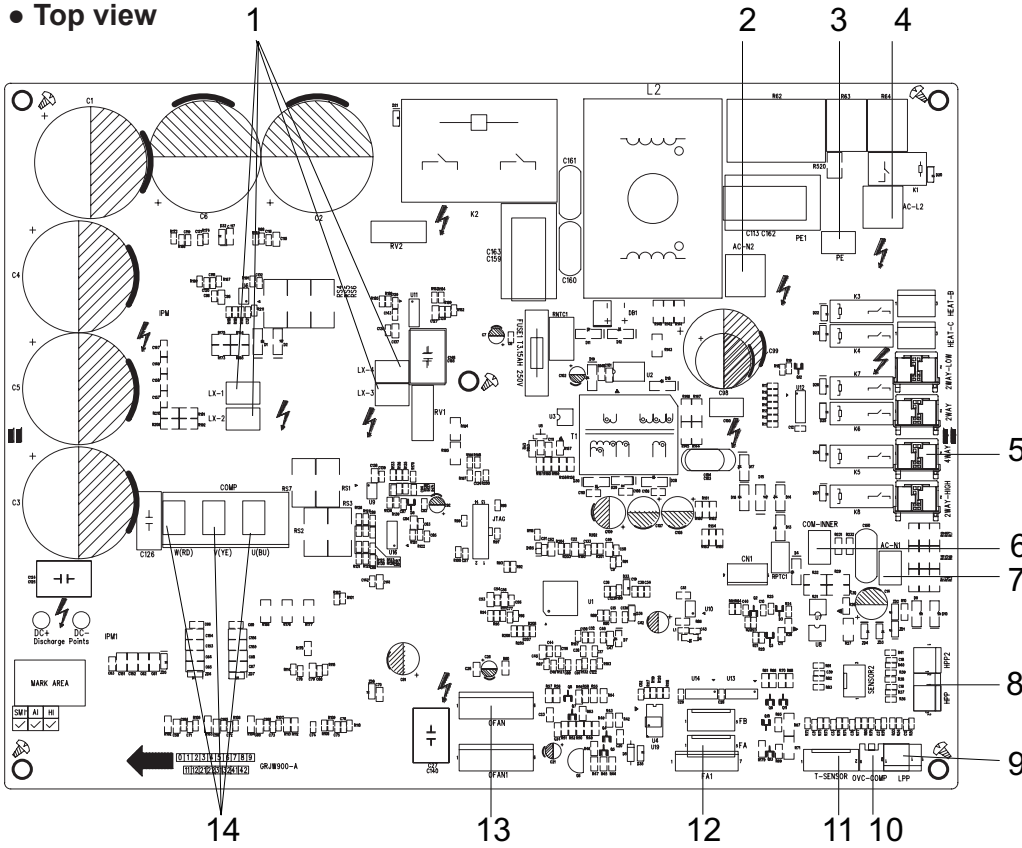

1	Wiring terminal of PFC inductance
2	Interface of neutral wire
3	Interface of earthing wire
4	Interface of live wire
5	4-way valve terminal
6	Terminal of communication wire
7	Terminal of communication neutral wire
8	Terminal for high pressure protection
9	Terminal for low pressure protection
10	Compressor overload protection terminal
11	Terminal of temperature sensor
12	Terminal of electronic expansion valve
13	Terminal of fan
14	Compressor wiring terminal

• Bottom view

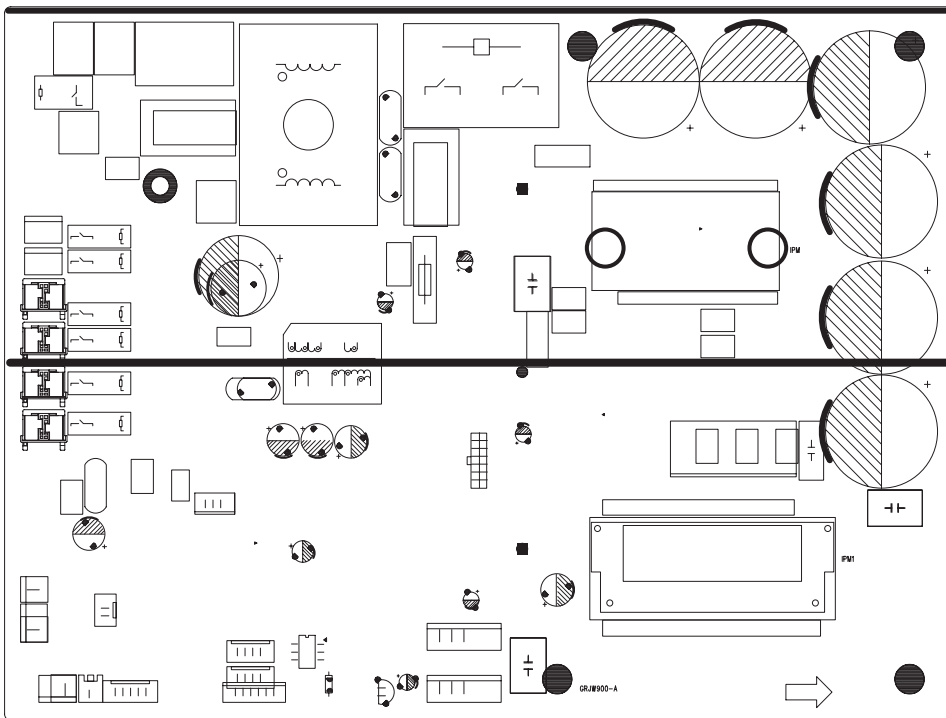

6. Function and Control

6.1 Function Buttons of Air Conditioner

Button's Name and Function

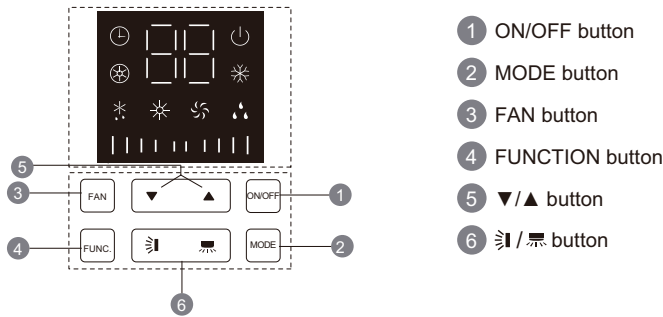

Introduction for icons on display screen of air conditioner

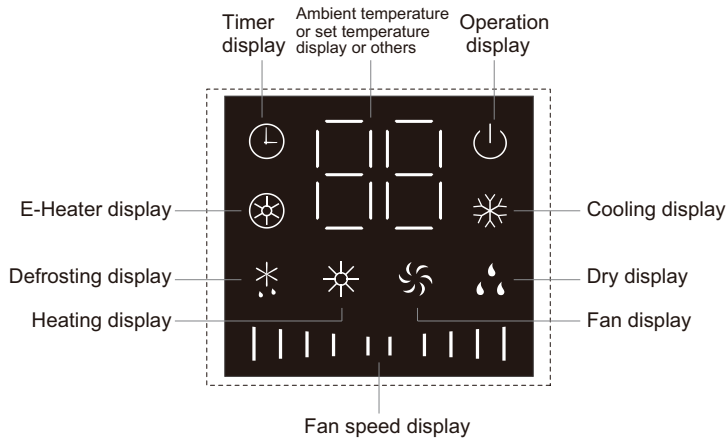

Note:

This series unit adopts touch buttons. You only need to touch the buttons slightly.

1 ON/OFF button

- Press this button to turn on or turn off the unit. (Note: Under X-FAN mode, press this button to turn on the unit directly.)

2 MODE button

- Every time press this button, the mode will switchover in cycle among.

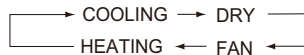

(Note: Cooling only unit won't accept heating operation signal. For cooling only unit, pressing MODE button under FAN mode will skip heating mode and enter cooling mode.)

3 FAN button

- Press this button and then fan speed can be selected and displayed in the sequence as below:

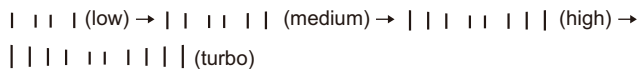

(Note: Only low fan speed is available for dry mode. Fan speed can't be adjusted under dry mode. Turbo cannot be set in FAN mode.)

4 FUNCTION button

- Under on status, press Function button to switch between timer and auxiliary heating function setting (auxiliary heating can be set only in heating mode). When timer or auxiliary heating icon is blinking, it means this function can be set. Press "▲" or "▼" button to set function. If there's no operation change within 5s after setting is finished, the function setting will be confirmed. Or press Function button again to exit or confirm the function. When the function is selected through Function button, if the unit is not turned off and no remote control signal is received within 2min, pressing Function button again to circulate from the previous set function. After 2min or the unit is turned off or remote control signal is received, pressing Function button again to circulate from timer icon. (Note: Only when the unit is under heating mode and with auxiliary heating function, auxiliary heating function can be turned on or off through Function button.)
- Under off status, if the unit is in X-FAN status, press Function button to turn off the unit directly; if the unit is not in X-FAN status, press Function button to set timer ON.

Button's introduction

5 ▼/▲ button

- After each pressing of "▲" or "▼" button, set temperature will increase or decrease 1°C. Temperature adjustment range is 16°C~30°C. This button is invalid under auto mode. Timer setting can be set in 1h increment among 0~24h. When it is adjusted to auxiliary heating function setting through Function button, press this button to turn on or turn off auxiliary heating. (Note: auxiliary heating is valid only for the model with this function.)
- Hold "▲" and "▼" buttons for 3s and the air conditioner will display "LC", which indicates buttons are locked. Any button under on status or ON/OFF button and function buttons under off status are all invalid. Hold these two button for 3s again to release the lock.

6 ↻/↺ button

- Left and right swing: this button controls the left and right swing motor, single press it to switchover between ON and OFF.
- Up and down swing: this button controls the up and down swing motor, single press it to switchover between ON and OFF.

Icon function introduction

Operation display

- It indicates the air conditioner is put through the power. Under on status, this indicator is on; under off status, this indicator is off.

Timer display

- When this indicator is on, it indicates the timer function is turned on.

Heating display

- When this indicator is on, it indicates the heating mode is turned on.

Defrosting display

- When this indicator is on, it indicates the defrosting function is turned on.

Dry display

- When this indicator is on, it indicates the dry mode is turned on.

E-Heater display (only for the mode with this function)

- When this indicator is on, it indicates the E-heater function is turned on.

Cooling display



- When this indicator is on, it indicates the cooling mode is turned on.

Fan display

- When this indicator is on, it indicates the fan mode is turned on.

Fan speed display

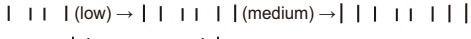
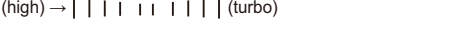
- Displays the fan speed. The fan speed is displayed as below:

 (low) →  (medium) →  (high) →  (turbo)

6.2 Remote Control Operations

Buttons on remote controller

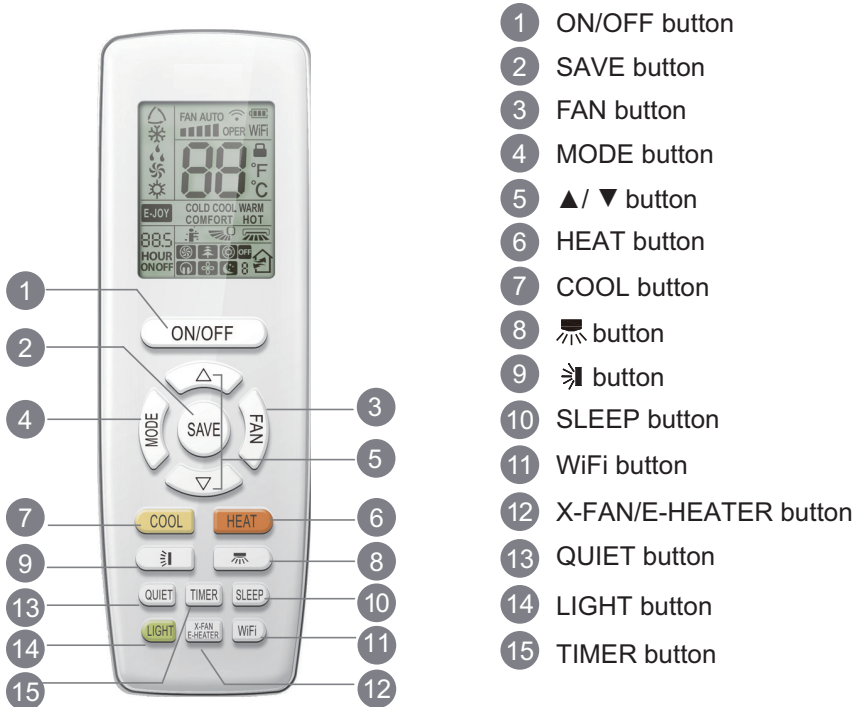

- 1 ON/OFF button
- 2 SAVE button
- 3 FAN button
- 4 MODE button
- 5 ▲/ ▼ button
- 6 HEAT button
- 7 COOL button
- 8 button
- 9 button
- 10 SLEEP button
- 11 WiFi button
- 12 X-FAN/E-HEATER button
- 13 QUIET button
- 14 LIGHT button
- 15 TIMER button

Introduction for icons on display screen

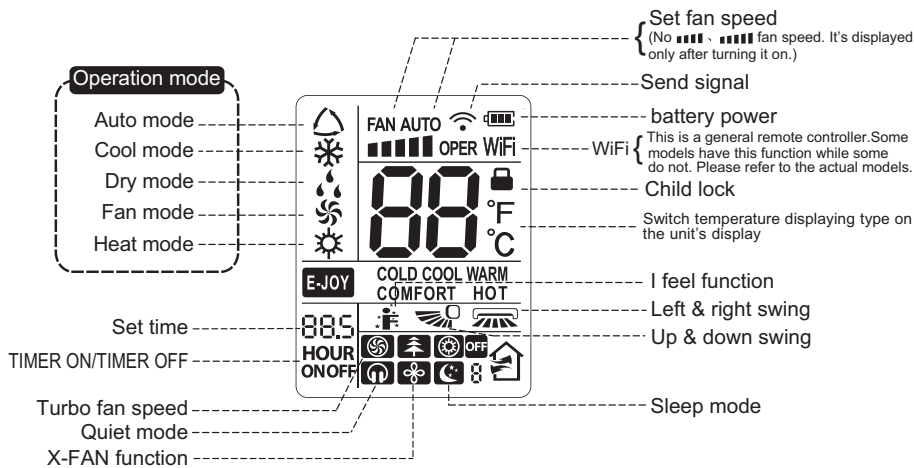





Introduction for buttons on remote controller

Note:



- This is a general remote controller, it could be used for the air conditioners with multifunction; For some function, which the model doesn't have, if press the corresponding button on the remote controller that the unit will keep the original running status.
- After putting through the power, the air conditioner will give out a sound. Operation indicator "⏻" is ON. (This indicator is not available for some models). After that, you can operate the air conditioner by using remote controller.
- Under on status, pressing the button on the remote controller, the signal icon "📶" on the display of remote controller will blink once and the air conditioner will give out a "di" sound, which means the signal has been sent to the air conditioner.

8 button



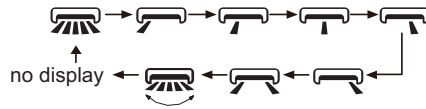

- Under simple swing mode, press this button can turn on ("" icon is displayed) or turn off ("" icon is not displayed) the left&right swing function.
- When the unit is turned off by remote controller, press "▲" button and "" button can switch between single swing mode and fixed-angle swing mode. "" on the remote controller will flash twice.

Under fixed-angle swing mode, press this button and then left&right swing status will circulate as shown in the right figure:





- This remote controller is the general type remote controller. When remote controller receives the signal of "", swing status is same as ""; when remote controller receives "", swing status is same as left&right swing OFF.

9 button

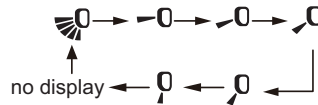
- Under simple swing mode, press this button can turn on ("" icon is displayed) or turn off ("" icon is not displayed) the up&down swing function.
- When the unit is turned off by remote controller, press "▲" button and "" button can switch between single swing mode and fixed-angle swing mode. "" on the remote controller will flash twice. Under fixed-angle swing mode, press this button and the up&down swing status will circulate as shown in the right figure:



10 SLEEP button

Under COOL, or HEAT mode, press this button to start up sleep function. "" icon is displayed on remote controller. Press this button again to cancel sleep function and "" icon will disappear. After powered on, Sleep Off is defaulted. After the unit is turned off, the Sleep function is canceled. In this mode, the time of time can be adjusted. Under Fan, DRY and Auto modes, this function is not available.

11 WiFi button

- Press "WiFi" button to turn on WiFi function, "WiFi" icon will be displayed on the remote controller; Hold "WiFi" button for 5s to turn off WiFi function and "WiFi" icon will disappear. Under off status, press "MODE" and "WiFi" buttons simultaneously for 1s, WiFi module will restore factory settings.
- This function is only available for some models.

12 X-FAN/E-HEATER button (only for the mode with this function)

Pressing this button in COOL or DRY mode, the icon "" is displayed and the indoor fan will continue operation for a few minutes in order to dry the indoor unit even though you have turned off the unit. After energization, X-FAN OFF is defaulted. X-FAN is not available in AUTO, FAN or HEAT mode. This function indicates that moisture on evaporator of indoor unit will be blown after the unit is stopped to avoid mould.

- Having set X-FAN function on: After turning off the unit by pressing ON/OFF button indoor fan will continue running for about a few minutes. at low speed. In this period, press X-FAN button to stop indoor fan directly.
- Having set X-FAN function off: After turning off the unit by pressing ON/OFF button, the complete unit will be off directly.
- Only under cooling mode and dry mode, press this button can turn on (characters of "X-FAN" are displayed) or turn off (characters of "X-FAN" are not displayed) X-FAN function.
- Under heating mode, press this button and the E-HEATER status will changed circularly as below:

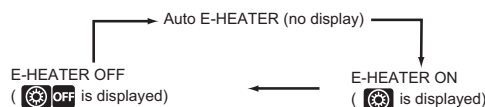

13 QUIET button

Press this button can turn on or turn off QUIET function.

- This function is not available for this unit.

14 LIGHT button

Press this button to turn off display light on indoor unit. Press this button again to turn on display light.

15 TIMER button

- At ON status, press this button once can set TIMER OFF. The character of HOUR and OFF will flash. Press "▲" or "▼" button within 5s can adjust the time of TIMER ON. After each pressing of "▲" or "▼" button, time will increase or decrease half an hour. When holding "▲" or "▼" button, 2s later, the time will change quickly until to reach to your required time. After that, press "TIMER" button to confirm it. The character of HOUR and OFF won't flash again.
Cancel TIMER OFF: Press "TIMER" button again under TIMER OFF status.
- At OFF status, press this button once can set TIMER ON. Please refer to TIMER off for detailed operation.
Cancel TIMER ON: Press "TIMER" button again under TIMER ON status.

Note:

- Time setting range: 0.5-24 hours.
- Time interval between two operations can't exceed 5s. Otherwise, remote controller will exit the setting status automatically.

Function introduction for combination buttons**Child lock function**

Press "▲" and "▼" simultaneously to turn on or turn off child lock function. When child lock function is on, "🔒" icon is displayed on remote controller. If you operate the remote controller, the "🔒" icon will blink three times without sending signal to the unit.

Temperature display switchover function

Under OFF status, press "▼" and "MODE" buttons simultaneously to switch temperature display between °C and °F .

If "H1" is displayed on the remote controller while it's not operated by the professional person/after-sales person, it belongs to the misoperation. Please operate it as below to cancel it. Under the OFF status of remote controller, hold the "MODE" button and "X-FAN" buttons simultaneously for 5s to cancel "H1" display.

Note:

- If remote controller displays "H1", it belongs to the normal function reminder. If the unit is defrosting under heating mode, it operates according to H1 defrosting mode. "H1" won't be displayed on the panel of indoor unit;
- Once you set H1 mode, if you turn off unit by remote controller, H1 will display 3 times on the remote controller and then disappear;
- Also, when you set H1 mode, when you change to heating mode, H1 will display 3 times on the remote controller and then disappear.

Operation guide

1. After putting through the power, press "ON/OFF" button on remote controller to turn on the air conditioner.
2. Press "MODE" button to select your required mode: AUTO, COOL, DRY, FAN, HEAT.
3. Press "▲" or "▼" button to set your required temperature. (Temperature can't be adjusted under auto mode).
4. Press "FAN" button to set your required fan speed: auto, low speed, medium speed, high speed, turbo speed.
5. Press "🌀" button to select fan blowing angle.

Replacement of batteries in remote controller

1. Lift the cover along the direction of arrow (as shown in Fig 1 ①).
2. Take out the original batteries (as shown in Fig 1 ②).
3. Place two 7# (AAA 1.5V) dry batteries, and make sure the position of "+" polar and "-" polar is correct (as shown in Fig 2 ③).
4. Reinstall the cover (as shown in Fig 2 ④).

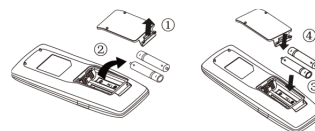

Fig.1

Fig.2

NOTICE

- During operation, point the remote control signal sender at the receiving window on indoor unit.
- The distance between signal sender and receiving window should be no more than 8m, and there should be no obstacles between them.
- Signal may be interfered easily in the room where there is fluorescent lamp or wireless telephone; remote controller should be close to indoor unit during operation.
- Replace new batteries of the same model when replacement is required.
- When you don't use remote controller for a long time, please take out the batteries.

6.3 Description of Each Control Operation

Note: Heating function is not available for this model.

1. Basic Functions

1.1 Cooling Mode

When $T_{amb} \geq T_{preset} + 1^{\circ}\text{C}$, the unit will run in cooling mode. Meanwhile, compressor and outdoor fan will run. Indoor fan will run at setting fan speed;

When $T_{amb} \leq T_{preset} - 1^{\circ}\text{C}$, the unit will stop running in cooling mode. Compressor and outdoor fan will stop running, while indoor fan is still running at setting fan speed;

When $T_{preset} - 1^{\circ}\text{C} < T_{amb} < T_{preset} + 1^{\circ}\text{C}$, the unit will keep previous running status;

1.2 Dry Mode

When $T_{amb} > T_{preset} + 2^{\circ}\text{C}$, the unit will run at cooling mode. Meanwhile, compressor and outdoor fan will run. Indoor fan will run at low fan speed.

When $T_{preset} - 2^{\circ}\text{C} \leq T_{amb} \leq T_{preset} + 2^{\circ}\text{C}$, compressor and outdoor fan will run for 6mins and then stop running for 4mins and they will run like that circularly. Indoor fan will run at low fan speed;

When $T_{amb} < T_{preset} - 2^{\circ}\text{C}$, compressor and outdoor fan will stop running. Indoor fan will run at low fan speed.

1.3 Heating Mode

When $T_{amb} \leq T_{preset} - 1^{\circ}\text{C}$, the unit will run in heating mode and the corresponding load will start running. Indoor fan will run at the condition of anti cold wind.

When $T_{amb} \geq T_{preset} + 1^{\circ}\text{C}$, the corresponding load will be stopped. Indoor fan will run at setting fan speed and the condition of blowing residual heat.

When $T_{preset} < T_{amb} < T_{preset} + 1^{\circ}\text{C}$, the unit will keep previous running status.

1.4 Fan Mode

Indoor fan will run at setting fan speed. Compressor, outdoor fan and reversing valve will stop running.

1.5 Auto Mode

In this mode, the unit will decide its running mode according to the ambient temperature.

When $T_{amb} > 26^{\circ}\text{C}$, the unit will run in cooling mode. Internal setting temperature is 26°C ;

When $20^{\circ}\text{C} \leq T_{amb} \leq 26^{\circ}\text{C}$, the unit will run in dry mode. Internal setting temperature is 24°C ;

When $T_{amb} < 20^{\circ}\text{C}$, the unit will run in heating mode. Internal setting temperature is 20°C . When $T_{amb} \geq 24^{\circ}\text{C}$, the unit will quit from the heating mode. As for the cooling only unit, when $T_{amb} < 20^{\circ}\text{C}$, the unit will run at fan mode and the internal setting temperature is 20°C . When $T_{amb} \geq 24^{\circ}\text{C}$, the unit will quit from the fan mode.

2. Protection Function

2.1 Indoor Antifreezing Protection

When antifreezing protection is detected, the corresponding load will be stopped. After the antifreezing protection is released, controller will run at setting mode. Buttons won't be shielded during the antifreezing protection.

2.2 High Pressure Protection of System

When high pressure protection is detected, the corresponding load will be stopped. All button and remote control signal will be shielded and E1 will be displayed; after high pressure protection of compressor is released, all buttons and remote control signal will become normal.

2.3 Low Pressure Protection of System

When low pressure protection is detected for the first time, the corresponding load will be stopped and the indicator will blink. If the low pressure protection is detected for twice successively, the corresponding load will be stopped and E3 will be displayed. They can't resume automatically.

2.4 High Temperature Protection for Discharge Pipe

When high temperature protection for discharge pipe is detected, the corresponding load will be stopped. E4 will be displayed.

2.5 Indoor High Temperature Resistant Protection

When high temperature resistant protection is detected, the corresponding load will be stopped.

2.6 Overcurrent Protection

When overcurrent protection is detected, the corresponding load will be stopped and E5 will be displayed.

3. Other Function

3.1 Defrosting

The unit will judge according to the tube temperature and ambient temperature, when it's detected that the outdoor condenser is frosting, the unit will start defrosting. Indoor fan and four-way valve will stop running. After defrosting is finished, the unit will start heating normally. During the time of defrosting, Defrosting indicator is on.

3.2 Swing Function

Users can start up or stop the function of up&down swing, right&left swing.

3.3 Sleep

- ① If the controller is in cooling or dry mode, after the sleep function is started, Tpreset will be increased but it won't increase over 3°C. Then the unit will run at the increased temperature.
- ② If the controller is in heating mode, after the sleep function is started, Tpreset will be decreased and it won't decrease over 3°C. Then the unit will run at the decreased temperature.

3.4 Timer

Timer ON and timer OFF can be set by remote controller or buttons and the setting range is 0.5~24hrs.

3.5 Buzzer

Upon energization and operation, the buzzer will give out a beep.

3.6 Power-off Memory Function

Memory content: mode, up&dwon swing (7 statuses), right&left swing (ON/OFF), setting temperature, setting fan speed, health, light, timer. After power failure, the unit will run according to the memory content automatically when power recovered. If energize the unit after power failure and the unit is turned on before power failure, the compressor will be delayed for 3mins for protection; if the unit is turned off before power failure, the compressor won't be delayed for 3mins for protection. If the timer is reached before power failure, the unit will run according to the mode before power failure after power recovered; if the timer isn't reached, the timer will be continued and time will be recalculated.

3.7 LED Display Module Control

1. Indicator control

Indicator will be displayed according to current operation function.

2. Use the light button on remote controller to turn off the LED display: When cancel the "light" by remote controller, the complete display screen will go out except the running indicator.

3.8 Buttons

- ① ON/OFF button: This button is used for control the on/off of controller. After each pressing of this button, the on/off status will be changes for once.
- ② Mode button: After pressing the mode button, it will be selected and display as: auto—cooling—drying—fan—heating (not available for cooling only unit).
- ③ +and – buttons: This two buttons are used for adjusting temperature and timer;
- ④ Up&down button: This button is used for control the up&down swing motor and it will be selected and displayed as: angle 1→angle 2→angle 3 →angle 4→angle 5→to-and-fro swing →stop swing.
- ⑤ Fan speed button: fan speed will be selected as: auto—low—medium—high—super-high;
- ⑥ Right&left swing button: This button is used for control the on/off of right&left swing motor. After each pressing this button, the on/off status of the right&left swing motor will be changed for once.

6.4 Ewpe Smart App Operation Manual

Control Flow Chart

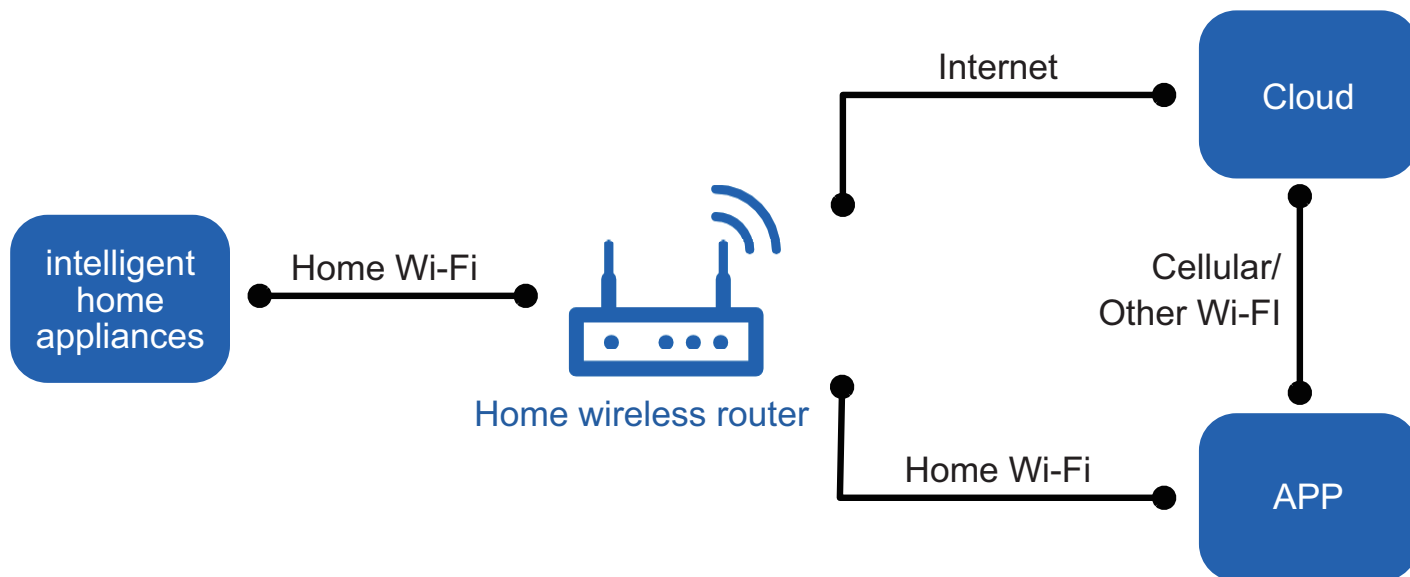

Operating Systems

Requirement for User's smart phone:



iOS system
Support iOS7.0 and
above version



Android system
Support Android 4.4 and
above version

Download and installation



App Download Linkage

Scan the QR code or search "Ewpe Smart" in the application market to download and install it. When "Ewpe Smart" App is installed, register the account and add the device to achieve long-distance control and LAN control of smart home appliances. For more information, please refer to "Help" in App.

Part II : Installation and Maintenance

7. Notes for Installation and Maintenance

Safety Precautions: Important!

Please read the safety precautions carefully before installation and maintenance.

The following contents are very important for installation and maintenance.

Please follow the instructions below.

- The installation or maintenance must accord with the instructions.
- Comply with all national electrical codes and local electrical codes.
- Pay attention to the warnings and cautions in this manual.
- All electric work must be performed by a licensed technician according to local regulations and the instructions given in this manual.
- Be caution during installation and maintenance. Prohibit incorrect operation to prevent electric shock, casualty and other accidents.



Warnings

Electrical Safety Precautions:

1. Cut off the power supply of air conditioner before checking and maintenance.
2. The air condition must apply specialized circuit and prohibit share the same circuit with other appliances.
3. The air conditioner should be installed in suitable location and ensure the power plug is touchable.
4. Make sure each wiring terminal is connected firmly during installation and maintenance.
5. Have the unit adequately grounded. The grounding wire can't be used for other purposes.
6. Must apply protective accessories such as protective boards, cable-cross loop and wire clip.
7. The live wire, neutral wire and grounding wire of power supply must be corresponding to the live wire, neutral wire and grounding wire of the air conditioner.
8. The power cord and power connection wires can't be pressed by hard objects.
9. If power cord or connection wire is broken, it must be replaced .

10. If the power cord or connection wire is not long enough, please get the specialized power cord or connection wire from the manufacture or distributor. Prohibit prolong the wire by yourself.

11. For the air conditioner without plug, an air switch must be installed in the circuit. The air switch should be all-pole parting and the contact parting distance should be more than 3mm.

12. Make sure all wires and pipes are connected properly and the valves are opened before energizing.

13. Check if there is electric leakage on the unit body. If yes, please eliminate the electric leakage.

14. Replace the fuse with a new one of the same specification if it is burnt down; don't replace it with a cooper wire or conducting wire.

15. If the unit is to be installed in a humid place, the circuit breaker must be installed.

Installation Safety Precautions:

1. Select the installation location according to the requirement of this manual.(See the requirements in installation part)
2. Handle unit transportation with care; the unit should not be carried by only one person if it is more than 20kg.
3. When installing the indoor unit and outdoor unit, a sufficient fixing bolt must be installed; make sure the installation support is firm.
4. Ware safety belt if the height of working is above 2m.
5. Use equipped components or appointed components during installation.
6. Make sure no foreign objects are left in the unit after finishing installation.

When refrigerant leaks or requires discharge during installation, maintenance, or disassembly, it should be handled by certified professionals or otherwise in compliance with local laws and regulations.

Refrigerant Safety Precautions:

1. Avoid contact between refrigerant and fire as it generates poisonous gas; Prohibit prolong the connection pipe by welding.
2. Apply specified refrigerant only. Never have it mixed with any other refrigerant. Never have air remain in the refrigerant line as it may lead to rupture or other hazards.
3. Make sure no refrigerant gas is leaking out when installation is completed.
4. If there is refrigerant leakage, please take sufficient measure to minimize the density of refrigerant.
5. Never touch the refrigerant piping or compressor without wearing glove to avoid scald or frostbite.

Improper installation may lead to fire hazard, explosion, electric shock or injury.

Safety Precautions for Installing and Relocating the Unit:

To ensure safety, please be mindful of the following precautions.



Warnings

1. When installing or relocating the unit, be sure to keep the refrigerant circuit free from air or substances other than the specified refrigerant.

Any presence of air or other foreign substance in the refrigerant circuit will cause system pressure rise or compressor rupture, resulting in injury.

2. When installing or moving this unit, do not charge the refrigerant which is not comply with that on the nameplate or unqualified refrigerant.

Otherwise, it may cause abnormal operation, wrong action, mechanical malfunction or even series safety accident.

3. When refrigerant needs to be recovered during relocating or repairing the unit, be sure that the unit is running in cooling mode. Then, fully close the valve at high pressure side (liquid valve). About 30-40 seconds later, fully close the valve at low pressure side (gas valve), immediately stop the unit and disconnect power. Please note that the time for refrigerant recovery should not exceed 1 minute.

If refrigerant recovery takes too much time, air may be sucked in and cause pressure rise or compressor rupture, resulting in injury.

4. During refrigerant recovery, make sure that liquid valve and gas valve are fully closed and power is disconnected before detaching the connection pipe.

If compressor starts running when stop valve is open and connection pipe is not yet connected, air will be sucked in and cause pressure rise or compressor rupture, resulting in injury.

5. When installing the unit, make sure that connection pipe is securely connected before the compressor starts running.

If compressor starts running when stop valve is open and connection pipe is not yet connected, air will be sucked in and cause pressure rise or compressor rupture, resulting in injury.

6. Prohibit installing the unit at the place where there may be leaked corrosive gas or flammable gas.

If there leaked gas around the unit, it may cause explosion and other accidents.

7. Do not use extension cords for electrical connections. If the electric wire is not long enough, please contact a local service center authorized and ask for a proper electric wire.

Poor connections may lead to electric shock or fire.

8. Use the specified types of wires for electrical connections between the indoor and outdoor units. Firmly clamp the wires so that their terminals receive no external stresses.

Electric wires with insufficient capacity, wrong wire connections and insecure wire terminals may cause electric shock or fire.

Safety Precautions for Refrigerant

•To realize the function of the air conditioner unit, a special refrigerant circulates in the system. The used refrigerant is the fluoride R32, which is specially cleaned. The refrigerant is flammable and inodorous. Furthermore, it can lead to explosion under certain conditions. But the flammability of the refrigerant is very low. It can be ignited only by fire.

•Compared to common refrigerants, R32 is a nonpolluting refrigerant with no harm to the ozoneosphere. The influence upon the greenhouse effect is also lower. R32 has got very good thermodynamic features which lead to a really high energy efficiency. The units therefore need a less filling.

WARNING:

•Do not use means to accelerate the defrosting process or to clean, other than those recommended by the manufacture.

Should repair be necessary, contact your nearest authorized Service Centre. Any repairs carried out by unqualified personnel may be dangerous. The appliance shall be stored in a room without continuously operating ignition sources. (for example: open flames, an operating gas appliance or an operating electric heater.)

•Do not pierce or burn.

•Appliance shall be installed, operated and stored in a room with a floor area larger than 4m² (or 6m²).

•Appliance filled with flammable gas R32. For repairs, strictly follow manufacturer's instructions only. Be aware that refrigerants not contain odour.

•Read specialist's manual.

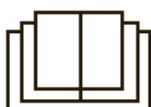

Safety Operation of Flammable Refrigerant

Qualification requirement for installation and maintenance man

- All the work men who are engaging in the refrigeration system should bear the valid certification awarded by the authoritative organization and the qualification for dealing with the refrigeration system recognized by this industry. If it needs other technician to maintain and repair the appliance, they should be supervised by the person who bears the qualification for using the flammable refrigerant.
- It can only be repaired by the method suggested by the equipment’s manufacturer.

Installation notes

- The air conditioner is not allowed to use in a room that has running fire (such as fire source,working coal gas ware, operating heater).
- It is not allowed to drill hole or burn the connection pipe.
- The air conditioner must be installed in a room that is larger than the minimum room area.
The minimum room area is shown on the nameplate or following table a.
- Leak test is a must after installation.

table a - Minimum room area(m²)

Minimum room area(m ²)	Charge amount (kg)	≤1.2	1.3	1.4	1.5	1.6	1.7	1.8	1.9	2	2.1	2.2	2.3	2.4	2.5
	floor location	4	14.5	16.8	19.3	22	24.8	27.8	31	34.3	37.8	41.5	45.4	49.4	53.6
window mounted	4	5.2	6.1	7	7.9	8.9	10	11.2	12.4	13.6	15	16.3	17.8	19.3	
wall mounted	4	4	4	4	4	4	4	4	4	4	4.2	4.6	5	5.5	6
ceiling mounted	4	4	4	4	4	4	4	4	4	4	4	4	4	4	4

Maintenance notes

- Check whether the maintenance area or the room area meet the requirement of the nameplate.
— It’s only allowed to be operated in the rooms that meet the requirement of the nameplate.
- Check whether the maintenance area is well-ventilated.
— The continuous ventilation status should be kept during the operation process.
- Check whether there is fire source or potential fire source in the maintenance area.
— The naked flame is prohibited in the maintenance area; and the “no smoking” warning board should be hanged.
- Check whether the appliance mark is in good condition.
— Replace the vague or damaged warning mark.

Welding

- If you should cut or weld the refrigerant system pipes in the process of maintaining, please follow the steps as below:
 - a. Shut down the unit and cut power supply
 - b. Eliminate the refrigerant
 - c. Vacuuming
 - d. Clean it with N₂ gas
 - e. Cutting or welding
 - f. Carry back to the service spot for welding
- Make sure that there isn’t any naked flame near the outlet of the vacuum pump and it’s well-ventilated.
- The refrigerant should be recycled into the specialized storage tank.

Filling the refrigerant

- Use the refrigerant filling appliances specialized for R32. Make sure that different kinds of refrigerant won’t contaminate with each other.
- The refrigerant tank should be kept upright at the time of filling refrigerant.
- Stick the label on the system after filling is finished (or haven’t finished).
- Don’t overfilling.
- After filling is finished, please do the leakage detection before test running; another time of leak detection should be done when it’s removed.

Safety instructions for transportation and storage

- Please use the flammable gas detector to check before unload and open the container.
- No fire source and smoking.
- According to the local rules and laws.

Main Tools for Installation and Maintenance

<p>1. Measuring tape</p> 	<p>2. Screw driver</p> 	<p>3. Impact drill, drill head, electric drill</p> 
<p>4. Electroprobe</p> 	<p>5. Universal meter</p> 	<p>6. Torque wrench, open-end wrench, inner hexagon spanner</p> 
<p>7. Electronic leakage detector</p> 	<p>8. Vacuum pump</p> 	<p>9. Pressure meter</p> 
<p>10. Pipe pliers, pipe cutter</p> 	<p>11. Pipe expander, pipe bender</p> 	<p>12. Soldering appliance, refrigerant container</p>  <p>13. Electronic scale</p> 

8. Installation

8.1 Installation Dimension Diagram

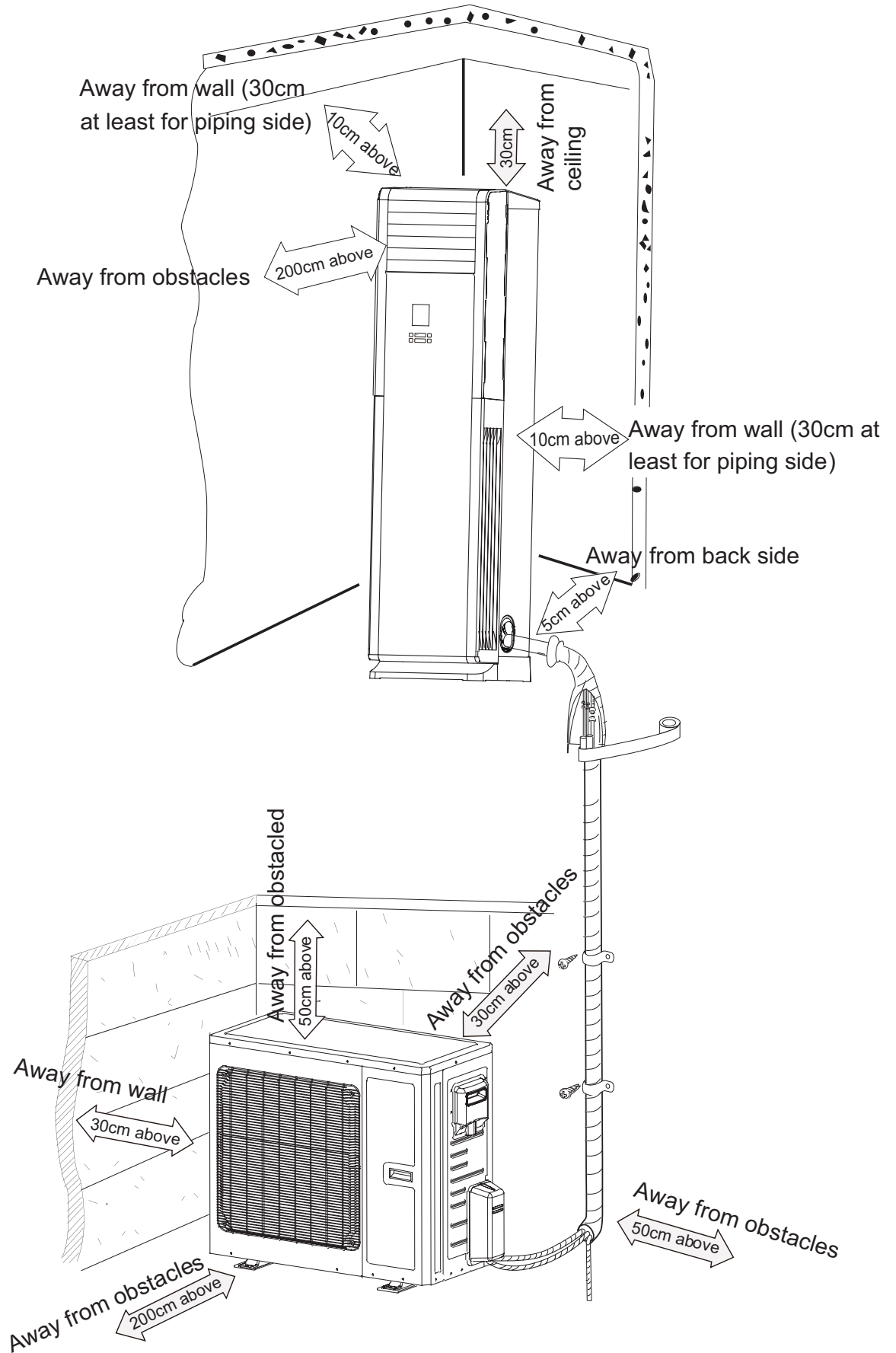

Installation procedures

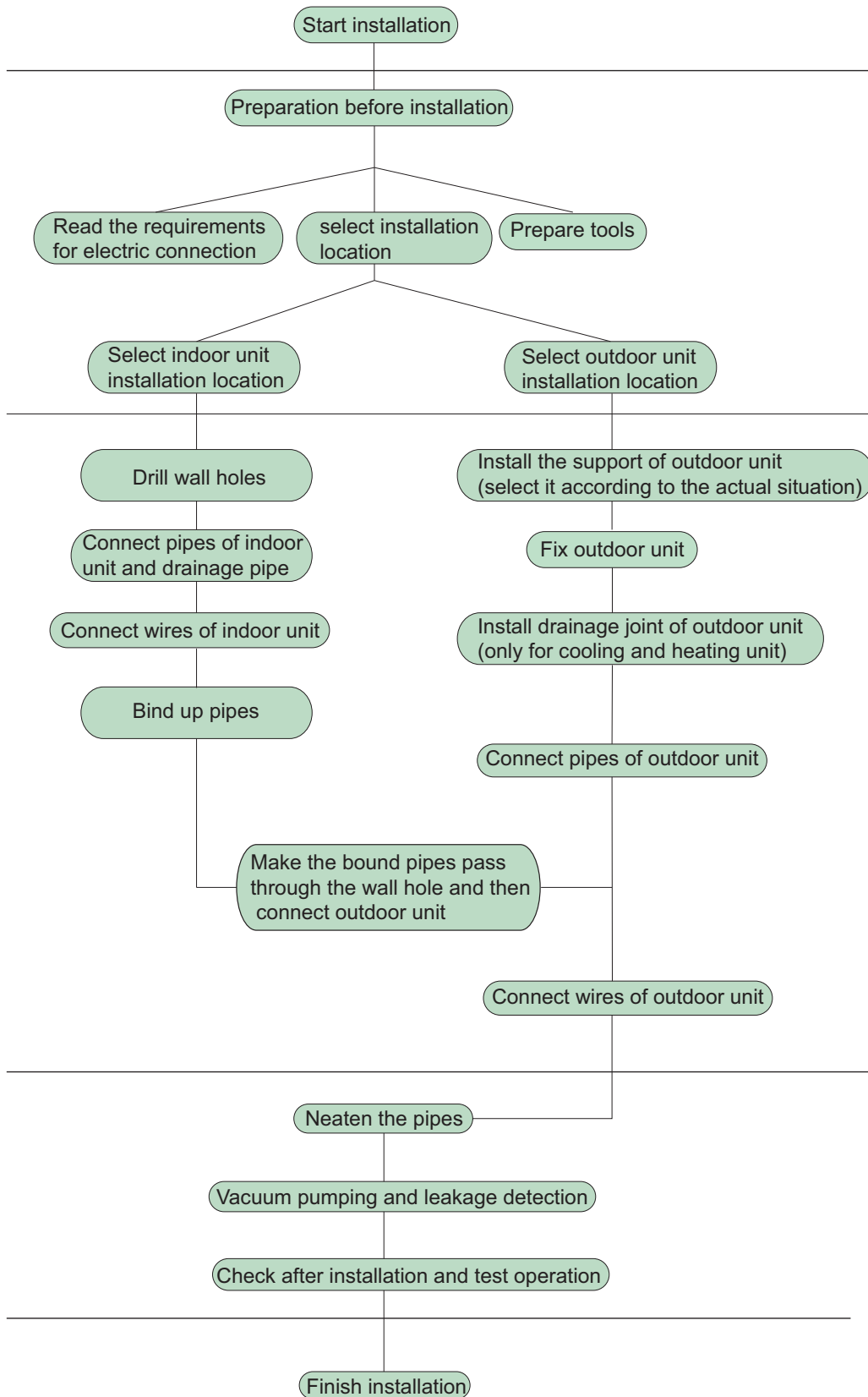

Note: this flow is only for reference; please find the more detailed installation steps in this section.

8.2 Installation Parts-checking

No.	Name	No.	Name
1	Indoor unit	7	Sealing gum
2	Outdoor unit	8	Wrapping tape
3	Connection pipe	9	Support of outdoor unit
4	Drainage pipe	10	Fixing screw
5	Connecting cable(power cord)	11	Drainage plug(cooling and heating unit)
6	Wall pipe	12	Owner's manual, remote controller

⚠ Note:

- 1.Please contact the local agent for installation.
- 2.Don't use unqualified power cord.

8.3 Selection of Installation Location

Basic Requirement:

Installing the unit in the following places may cause malfunction. If it is unavoidable, please consult the local dealer:

- 1.The place with strong heat sources, vapors, flammable or explosive gas, or volatile objects spread in the air.
- 2.The place with high-frequency devices (such as welding machine, medical equipment).
- 3.The place near coast area.
- 4.The place with oil or fumes in the air.
- 5.The place with sulfureted gas.
- 6.Other places with special circumstances.
7. Please try your best to keep way from fluorescent lamp.
- 8.It's not allowed to be installed on the unstable or motive base structure (such as truck) or in the corrosive environment (such as chemical factory).

Indoor Unit:

1. Avoid installing the indoor unit in a place where generated or leaked inflammable gas will stay.
2. Avoid installing the indoor unit in a moist place or in a place where oil may be splashed on the unit.
3. Select a location where outlet air may reach each corner of the room.
4. Select a location where connection pipe can be led to outdoor conveniently.
5. Select a location where air inlet and outlet won't be blocked.
6. Select a location with least affection of outdoor air.
7. Select a location with firm and flat floor.
8. Retain sufficient space for maintenance and installation.
9. Ensure the installation meets the requirement of installation dimension diagram.
- 10.Do not use the unit in the immediate surroundings of a laundry a bath a shower or a swimming pool.

Outdoor Unit:

1. Select a location where the noise and outflow air emitted by the outdoor unit will not affect neighborhood.
2. The location should be well ventilated and dry, in which the outdoor unit won't be exposed directly to sunlight or strong wind.
3. The location should be able to withstand the weight of outdoor unit.
4. Make sure that the installation follows the requirement of installation dimension diagram.
5. Select a location which is out of reach for children and far away from animals or plants. If it is unavoidable, please add fence for safety purpose.
6. The height difference between indoor unit and outdoor unit should be within 5m. The length of connection pipe should be within 10m.

8.4 Requirements for electric connection

⚠ Safety Precaution:

- 1.Must follow the electric safety regulations when installing the unit.
- 2.If the supply cord is damaged, it must be replaced by the manufacturer or its service agent or a similarly qualified person in order to avoid a hazard.
- 3.According to the local safety regulations, use qualified power supply circuit and air switch
- 4.A air switch having a contact separation of at least 3mm in all poles should be fixed in fixed wiring.
- 5.The appliance shall be installed in accordance with national wiring regulation.
- 6.The air switch must have the functions of magnetic tripping and heat tripping in order to prevent short circuit or overload. Please install the air switch with suitable capacity according to the sheet below.
- 7.Make sure the power supply matches with the requirement of air conditioner.Unstable power supply or incorrect wiring may result in electric shock, fire hazard or malfunction. Please install proper power supply cables before using the air conditioner.
- 8.Properly connect the live wire, neutral wire and grounding wire of power socket.
- 9.Be sure to cut off the power supply before proceeding any work related to electric safety.
- 10.Do not put through the power before finishing installation.
- 11.To be in compliance with IEC/EN 61000-3-11, impedance value of power-supply system connected to product must be less than or equal to the allowable maximum value of $|Z_{sys}|$ in the following sheet:

Model	max $ Z_{sys} $ unit:ohm
AST-48BI	0.356

⚠ Grounding Requirement:

1. The air conditioner is first class electric appliance. It must be properly grounded with specialized grounding device by a professional. Please make sure it is always grounded effectively, otherwise it may cause electric shock.
2. The yellow-green wire in air conditioner is grounding wire, which can't be used for other purposes.
3. The grounding resistance should comply with national electric safety regulations.

Model	Capacity of air switch	Power cord specifications
48K	32A	4G0.75

8.5 Installation of Indoor Unit

Step one: choosing installation location

Recommend the installation location to the client and then confirm it with the client.

Step two: open piping hole

- 1.Choose the position of piping hole according to the direction of outlet pipe.
- 2.Open a piping hole with the diameter of $\Phi 70\text{mm}$ on the selected outlet pipe position. In order to drain smoothly, slant the piping hole on the wall slightly downward to the outdoor side with the gradient of $5\text{-}10^\circ$. (As show in Fig.1)

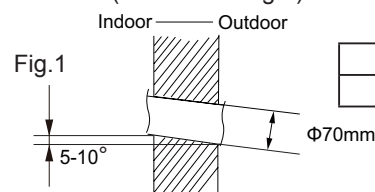

⚠ Note:

1. Pay attention to dust prevention and take relevant safety measures when opening the hole.
2. The plastic expansion particles are not provided and should be bought locally.

Step three: outlet pipe

1. The pipe can be led out in the direction of left, right or rear. (As show in Fig.2)
2. After confirming the direction of outlet pipe, loosen the screws at the upper and lower adjusting baffle to let the connection pipe/drain pipe connects the indoor unit. (As show in Fig.3)

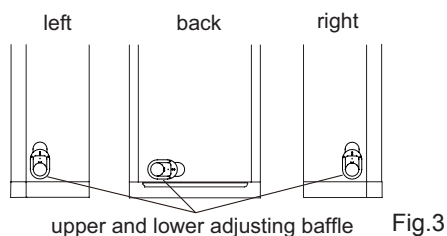
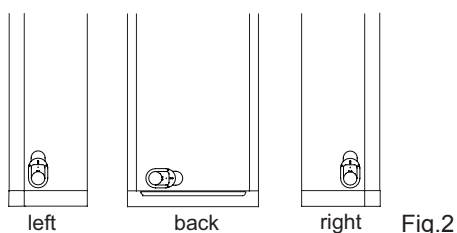

Step four: connect the pipe of indoor unit

1. Take out the left and right screw cover and then remove the screws on air-inlet panel to remove the panel. (As show in Fig.4)
2. Aim the pipe joint at the corresponding bellmouth. (As show in Fig.5)
3. Pretightening the union nut with hand.
4. Adjust the torque force by referring to the following sheet. Place the open-end wrench on the pipe joint and place the torque wrench on the union nut. Tighten the union nut with torque wrench. (As show in Fig.6)
5. Wrap the indoor pipe and joint of connection pipe with insulating pipe, and then wrap it with tape. (As show in Fig.7)

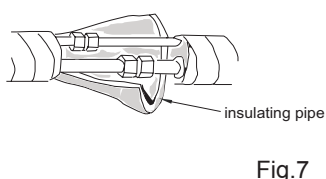
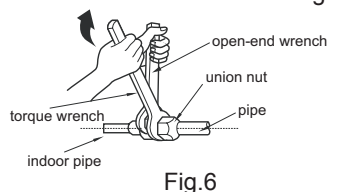
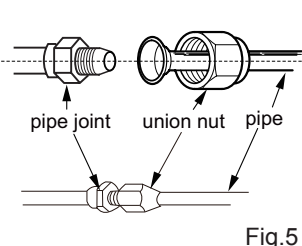
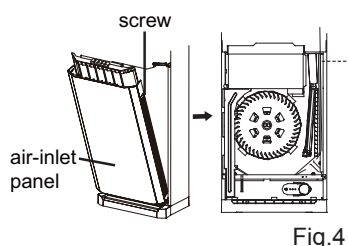

Refer to the following table for wrench moment of force:

Hex nut diameter(mm)	Tightening torque(N·m)
Φ6.35(1/4")	15.7(1.6kg·m)
Φ9.52(3/8")	29.4(3.0kg·m)
Φ12.70(1/2")	49.0(5.0kg·m)
Φ15.88(5/8")	73.6(7.5kg·m)

Step five: install drain hose

1. Connect the drain hose to the outlet pipe of indoor unit. (As show in Fig.8)
2. Bind the joint with tape. (As show in Fig.8)
3. Add insulating pipe in the indoor drain hose in order to prevent condensation. (As show in Fig.10)

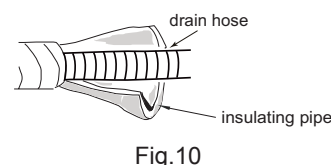
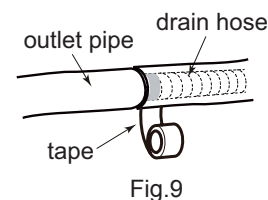
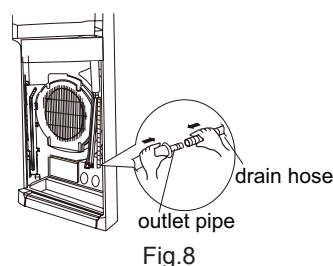

Step six: connect wire of indoor unit

1. Make the power connection wire go through the cable-cross hole of indoor unit (As show in Fig.11)

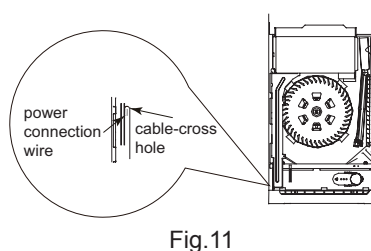

2. Remove the wire clip; connect the power connection wire to the wiring terminal according to the color; tighten the screw and then fix the power supply wire, power connection wire with wire clip. (As show in Fig.12)

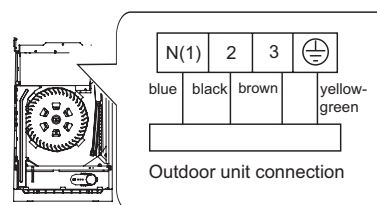

3. Adjust the position of upper and lower adjusting baffle; clamp the connection pipe and drain pipe as firm as possible.
4. Tighten the screws.

⚠ Note:

All wires of indoor unit and outdoor unit should be connected by a professional.

- 1.If the length of power connection wire is insufficient, please contact the supplier for a new one. Avoid extending the wire by yourself.
- 2.For the air conditioner with plug, the plug should be reachable after finishing installation.
- 3.For the air conditioner without plug, an air switch must be installed in the line. The air switch should be all-pole parting and the contact parting distance should be more than 3mm.

Step seven: bind up pipe

1. Bind up the connection pipe, power cord and drain hose with the band.(As show in Fig.13)
- 2.Reserve a certain length of drain hose and power cord for installation when binding them. When binding to a certain degree, separate the indoor power and then separate the drain hose.(As show in Fig.14)
3. Bind them evenly.
4. The liquid pipe and gas pipe should be bound separately at the end.

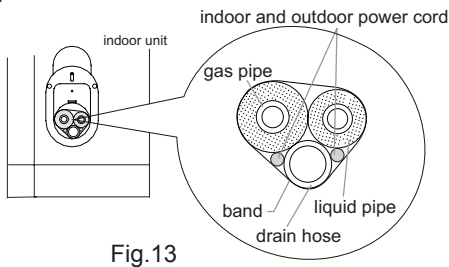

Fig.13

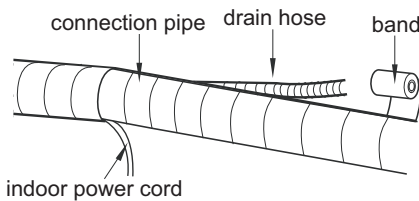

Fig.14

⚠ Note:

- 1.The power cord and control wire can't be crossed or winding.
- 2.The drain hose should be bound at the bottom.

Step Eight: place the indoor unit

- 1.Put the bound pipes in the wall pipe and then make them pass through the wall hole.
2. Stuff the gap between pipes and wall hole with sealing gum. (As show in Fig.15)
3. Fix the wall pipe.
- 4.Check if the indoor unit is installed firmly.

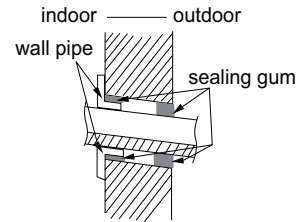

Fig.15

⚠ Note:

Do not bend the drain hose too excessively in order to prevent blocking.

8.6 Installation of Outdoor Unit

Step one: fix the support of outdoor unit (select it according to the actual installation situation)

1. Select installation location according to the house structure.
2. Fix the support of outdoor unit on the selected location with expansion screws.

⚠ Note:

- 1.Take sufficient protective measures when installing the outdoor unit.
- 2.Make sure the support can withstand at least four times the unit weight.
- 3.The outdoor unit should be installed at least 3cm above the floor in order to install drain joint.(As show in Fig.16)
- 4.For the unit with cooling capacity of 2300W~5000W, 6 expansion screws are needed; for the unit with cooling capacity of 6000W~8000W, 8 expansion screws are needed; for the unit with cooling capacity of 10000W~16000W, 10 expansion screws are needed.

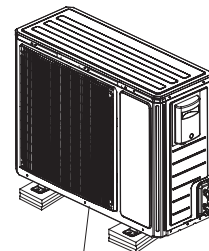

Fig.16

Step two: install drain joint (only for cooling and heating unit)

1. Connect the outdoor drain joint into the hole on the chassis, as shown in the picture below.

2. Connect the drain hose into the drain vent.(As show in Fig.17)

NOTE: As for the shape of drainage joint,please refer to the current product.Do not install the drainage joint in the severe cold area. Otherwise,it will be frosted and then cause malfunction

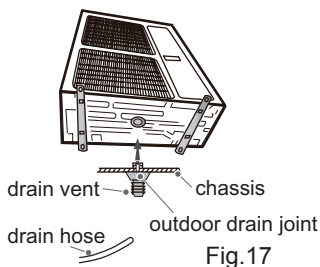

Fig.17

Step three: fix outdoor unit

1. Place the outdoor unit on the support.
2. Fix the foot holes of outdoor unit with bolts.(As show in Fig.18)

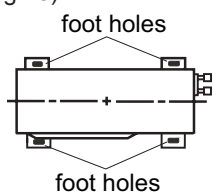

Fig.18

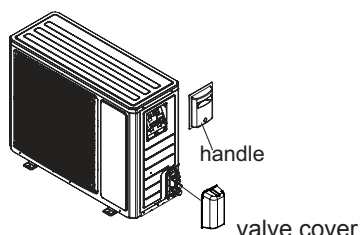

Fig.19

Step four: connect indoor and outdoor pipes

1. Remove the screw on the right handle of outdoor unit and then remove the handle.(As show in Fig.19)
2. Remove the screw cap of valve and aim the pipe joint at the bellmouth of pipe.(As show in Fig.20)

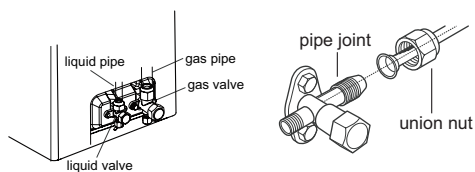

Fig.20

3. Pretightening the union nut with hand.
4. Tighten the union nut with torque wrench by referring to the sheet below.

Hex nut diameter(mm)	Tightening torque(N m)
Φ6.35(1/4")	15.7(1.6kg.m)
Φ9.52(3/8")	29.4(3.0kg.m)
Φ12.70(1/2")	49.0(5.0kg.m)
Φ15.88(5/8")	73.6(7.5kg.m)

Step five: connect outdoor electric wire

1. Remove the wire clip; connect the power connection wire to the wiring terminal according to the color; fix them with screws.(As show in Fig.21)

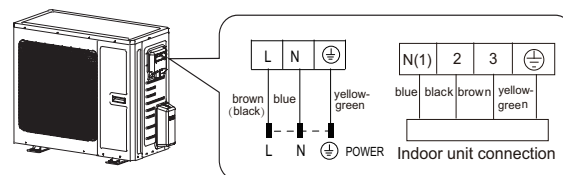

Fig.21

2. Fix the power connection wire with wire clip (only for cooling and heating unit).

Note:

- 1.After tightening the screw, pull the power cord slightly to check if it is firm.
2. Never cut the power connection wire to prolong or shorten the distance.

Step six: neaten the pipes

1. The pipes should be placed along the wall, bent reasonably and hidden possibly. Min. semidiameter of bending the pipe is 10cm.
2. If the outdoor unit is higher than the wall hole, you must set a U-shaped curve in the pipe before pipe goes into the room, in order to prevent rain from getting into the room. (As show in Fig.23)

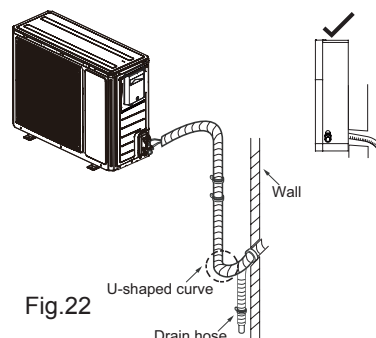

Fig.22

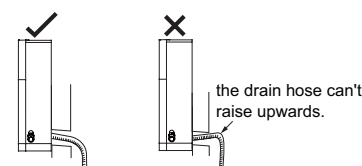

Fig.23

Note:

- 1.The through-wall height of drain hose shouldn't be higher than the outlet pipe hole of indoor unit.(As show in Fig.23)
- 2.Slant the drain hose slightly downwards. The drain hose can't be curved, raised and fluctuant, etc. (As show in Fig.24)
- 3.The water outlet can't be placed in water in order to drain smoothly.(As show in Fig.25)

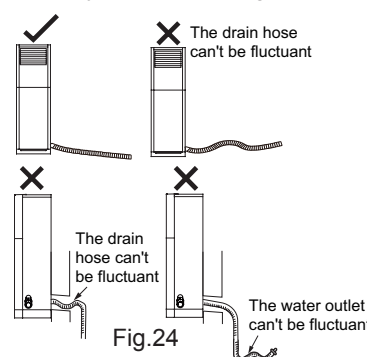

Fig.24

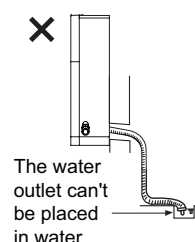

Fig.25

8.7 Vacuum Pumping and Leak Detection

Use Vacuum Pump

1. Remove the valve caps on the liquid valve and gas valve and the nut of refrigerant charging vent.
2. Connect the charging hose of piezometer to the refrigerant charging vent of gas valve and then connect the other charging hose to the vacuum pump.
3. Open the piezometer completely and operate for 10-15min to check if the pressure of piezometer remains in -0.1MPa.
4. Close the vacuum pump and maintain this status for 1-2min to check if the pressure of piezometer remains in -0.1MPa. If the pressure decreases, there may be leakage.
5. Remove the piezometer, open the valve core of liquid valve and gas valve completely with inner hexagon spanner.
6. Tighten the screw caps of valves and refrigerant charging vent. (As show in Fig.26)

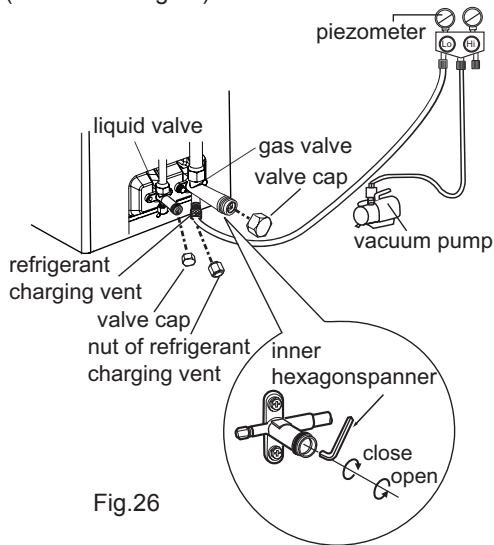

Fig.26

Leakage Detection

1. With leakage detector:

Check if there is leakage with leakage detector.

2. With soap water:

If leakage detector is not available, please use soap water for leakage detection. Apply soap water at the suspected position and keep the soap water for more than 3min. If there are air bubbles coming out of this position, there's a leakage.

8.8 Check after Installation and Test Operation

1. Check After Installation

Check according to the following requirement after finishing installation.

NO.	Items to be checked	Possible malfunction
1	Has the unit been installed firmly?	The unit may drop, shake or emit noise.
2	Have you done the refrigerant leakage test?	It may cause insufficient cooling (heating) capacity.
3	Is heat insulation of pipeline sufficient?	It may cause condensation and water dripping.
4	Is water drained well?	It may cause condensation and water dripping.
5	Is the voltage of power supply according to the voltage marked on the nameplate?	It may cause malfunction or damage the parts.
6	Is electric wiring and pipeline installed correctly?	It may cause malfunction or damage the parts.
7	Is the unit grounded securely?	It may cause electric leakage.
8	Does the power cord follow the specification?	It may cause malfunction or damage the parts.
9	Is there any obstruction in air inlet and air outlet?	It may cause insufficient cooling (heating) capacity.
10	The dust and sundries caused during installation are removed?	It may cause malfunction or damaging the parts.
11	The gas valve and liquid valve of connection pipe are open completely?	It may cause insufficient cooling (heating) capacity.
12	Is the inlet and outlet of piping hole been covered?	It may cause insufficient cooling (heating) capacity or waster eletricity.

2. Test Operation

- (1) Preparation of test operation

The client approves the air conditioner installation.

Specify the important notes for air conditioner to the client.

- (2) Method of test operation

Put through the power, press ON/OFF button on the remote controller to start operation. Press MODE button to select AUTO, COOL, DRY, FAN and HEAT to check whether the operation is normal or not. If the ambient temperature is lower than 16 °C , the air conditioner can't start cooling.

9. Troubleshooting

9.1 Judgement by Flashing LED of Indoor

No.	Malfunction Name	Error Code	A/C Status	Possible Causes
1	High pressure protection	E1	During cooling and drying operation, except indoor fan operates, all loads stop operation. During heating operation, if it is inverter unit, the complete unit stops; if it is floor standing unit, the complete unit stops and operation of remote controller or controller is unavailable.	<ol style="list-style-type: none"> 1. The main board and the display panel are not connected well. 2. The OVC terminal on main board is not connected well with the high pressure switch on the complete unit. 3. The wiring of high pressure switch is loosened. 4. Refrigerant is superabundant. 5. Poor heat exchange (including blocked heat exchanger and bad radiating environment). 6. Ambient temperature is too high.(if it is 3-phase unit, the high pressure protection may be caused by overcurrent protection due to this reason) 7. The supply voltage is abnormal.(if it is 3-phase unit, the high pressure protection may be caused by overcurrent protection due to this reason) 8. The air intake and air discharge at indoor / outdoor heat exchanger are not smooth. The air cycle is short circuited. 9. Filter and heat exchange fins of indoor/outdoor units are blocked. 10. The system pipeline is blocked. 11. The gas valve and liquid valve for outdoor unit are not completely opened. 12. The OVC input is at high level.
2	Freeze protection	E2	During cooling and drying operation, compressor and outdoor fan stop while indoor fan operates.	<ol style="list-style-type: none"> 1. Poor air-return in indoor unit. 2. Abnormal fan speed. 3. Dirty evaporator. 4. System is normal, but the indoor tube temperature sensor is abnormal, or the tube temperature sensor is not connected well.
3	Low pressure protection of compressor	E3	The complete unit stops	<ol style="list-style-type: none"> 1. The main board and display panel are not connected well. 2. The LPP terminal on the main board is not connected well with the high pressure switch on the complete unit. 3. The wiring of the high pressure switch is loosened. High pressure switch is damaged or poorly contacted. 4. Insufficient or leaking out refrigerant. 5. The LPP input is at high level.
4	High discharge temperature protection of compressor	E4	During cooling and drying operation, compressor and outdoor fan stop while indoor fan operates. During heating operation, all loads stop.	<ol style="list-style-type: none"> 1. Abnormal system (e.g.: blockage, etc) 2. Abnormal rotation speed of outdoor motor (cooling) 3. Abnormal air intake (cooling) 4. System is normal, but the compressor discharge temperature sensor is abnormal or poorly contacted.
5	Overcurrent protection	E5	During cooling and drying operation, compressor and outdoor fan stop while indoor fan operates. During heating operation, all loads stop.	<ol style="list-style-type: none"> 1. Unstable supply voltage. Normal fluctuation shall be within 10% of the rated voltage on the nameplate. 2. Supply voltage is too low and load is too high. 3. Measure the current of live wire on main board. If the current isn't higher than the overcurrent protection value, please check the controller. 4. The indoor and outdoor heat exchangers are too dirty, or the air inlet and air outlet are blocked. 5. The fan motor is not running. Abnormal fan speed: fan speed is too low or the fan doesn't run. 6. The compressor is not running normally. There is abnormal sound, oil leakage or the temperature of the shell is too high, etc. 7. There's blockage in the system. (filth blockage, ice plug, greasy blockage, Y-valve hasn't been opened completely)
6	Defrosting	Heating indicator off for 0.5s and then blinks for 10s	Not the error code. It's the status code for the operation	

No.	Malfunction Name	Error Code	A/C Status	Possible Causes
7	WIFI communication malfunction	JF	Loads operate normally, while the unit can't be normally controlled by APP.	1. Main board of indoor unit is damaged; 2. Detection board is damaged; 3. The connection between indoor unit and detection board is not good;
8	Communication malfunction	E6	During cooling operation, compressor stops while indoor fan motor operates. During heating operation, the complete unit stops.	Refer to the corresponding malfunction analysis.
9	Overload malfunction	E8	The entire unit stops.	1. Indoor and outdoor heat exchanger is too dirty? Or air inlet/outlet is blocked? 2. Fan motor doesn't work at a normal fan speed; fan speed is too low or the fan doesn't run. 3. Compressor operates normally or not? Is there any abnormal noise or oil leak? Casing is too hot? 4. System is blocked inside? (Dirt blockage? Ice blockage? Oil blockage? Y-valve is not fully open?) 5. Main board temperature sensor detects wrongly.
10	Overload protection for compressor	H3	During cooling and drying operation, compressor will stop while indoor fan will operate; During heating operation, the complete unit will stop operation.	1. Wiring terminal OVC-COMP is loosened. In normal state, the resistance for this terminal should be less than 1ohm. 2. Refer to the malfunction analysis (discharge protection, overload)
11	In defect of refrigerant	F0	The Dual-8 Code Display will show F0 and the complete unit stops.	1. In defect of refrigerant; 2. Indoor evaporator temperature sensor works abnormally; 3. The unit has been plugged up somewhere.
12	Indoor ambient temperature sensor is open/ short-circuited	F1	The unit will stop operation as it reaches the temperature point. During cooling and drying operation, except IDU fan motor operates, other loads stop operation; During heating operation, the heating fan motor operates according to the conditions of blowing residual heat.	1. The wiring terminal between indoor ambient temperature sensor and maiboard is loosened or poorly contacted; 2. There's short circuit due to trip-over of the parts on maiboard; 3. Indoor ambient temperature sensor is damaged (Please check it by referring to the resistance table for temperature sensor); 4. Mainboard is broken.
13	Indoor evaporator temperature sensor is open/ short-circuited	F2	The unit will stop operation as it reaches the temperature point. During cooling and drying operation, except IDU fan motor operates, other loads stop operation; During heating operation, the heating fan motor operates according to the conditions of blowing residual heat.	1. The wiring terminal between indoor evaporator temperature sensor and maiboard is loosened or poorly contacted; 2. There's short circuit due to trip-over of the parts on maiboard; 3. Indoor evaporator temperature sensor is damaged (Please check it by referring to the resistance table for temperature sensor); 4. Mainboard is broken.
14	Outdoor ambient temperature sensor is open/ short-circuited	F3	The unit will stop operation as it reaches the temperature point. During cooling and drying operation, the compressor stops operation while IDU fan motor operates; During heating operation, the heating fan motor operates according to the conditions of blowing residual heat.	1. The wiring terminal between outdoor ambient temperature sensor and maiboard is loosened or poorly contacted; 2. There's short circuit due to trip-over of the parts on maiboard; 3. Outdoor ambient temperature sensor is damaged (Please check it by referring to the resistance table for temperature sensor); 4. Mainboard is broken.
15	Outdoor condenser temperature sensor is open/ short-circuited	F4	The unit will stop operation as it reaches the temperature point. During cooling and drying operation, the compressor stops operation while IDU fan motor operates; During heating operation, the heating fan motor operates according to the conditions of blowing residual heat.	1. The wiring terminal between outdoor condenser temperature sensor and maiboard is loosened or poorly contacted; 2. There's short circuit due to trip-over of the parts on maiboard; 3. Outdoor condenser temperature sensor is damaged (Please check it by referring to the resistance table for temperature sensor); 4. Mainboard is broken.



No.	Malfunction Name	Error Code	A/C Status	Possible Causes
16	Outdoor discharge temperature sensor is open/short-circuited	F5	The unit will stop operation as it reaches the temperature point. During cooling and drying operation, the compressor stops operation while IDU fan motor operates; During heating operation, the heating fan motor operates according to the conditions of blowing residual heat.	1. The wiring terminal between outdoor discharge temperature sensor and maiboard is loosened or poorly contacted; 2. There's short circuit due to trip-over of the parts on maiboard; 3. Outdoor discharge temperature sensor is damaged (Please check it by referring to the resistance table for temperature sensor); 4. Mainboard is broken.
17	IPM protection	H5	"During cooling and drying operation, compressor will stop while indoor fan will operate; During heating operation, the complete unit will stop operation."	1. The compressor wiring connection is not well connected; 2. The compressor is damaged; 3. The Outdoor mainboard is damaged.
18	PFC protection	HC	"During cooling and drying operation, compressor will stop while indoor fan will operate; During heating operation, the complete unit will stop operation"	1. The unit voltage input is abnormal; 2. The inductance wire is not well connected; 3. The Outdoor mainboard is damaged.
19	Compressor loss step protection	H7	"During cooling and drying operation, compressor will stop while indoor fan will operate; During heating operation, the complete unit will stop operation."	1. The system pressure is too high; 2. The unit voltage input is too low; 3. The compressor wiring connection is not well connected; 4. The Outdoor mainboard is damaged.
20	Startup failure	LC	"During cooling and drying operation, compressor will stop while indoor fan will operate; During heating operation, the complete unit will stop operation."	1. The compressor wiring connection is not well connected; 2. There's too much refrigerant; 3. The compressor is damaged; 4. The Outdoor mainboard is damaged.
21	Capacitor charge malfunction	PU	"During cooling and drying operation, compressor will stop while indoor fan will operate; During heating operation, the complete unit will stop operation."	1. The unit voltage input is within abnormal range; 2. The electric reactor connection wiring is not well connected; 3. The Outdoor mainboard is damaged.
22	IPM sensor circuit malfunction	P7	"During cooling and drying operation, compressor will stop while indoor fan will operate; During heating operation, the complete unit will stop operation."	The Outdoor mainboard is damaged.
23	IPM high temperature protection	P8	"During cooling and drying operation, compressor will stop while indoor fan will operate; During heating operation, the complete unit will stop operation."	1. The temperature of IPM module is too high; 2. The Outdoor mainboard is damaged.
24	Over voltage protection for PN	PH	"During cooling and drying operation, compressor will stop while indoor fan will operate; During heating operation, the complete unit will stop operation."	1. The input voltage is too high; 2. The Outdoor mainboard is damaged.
25	Low PN voltage protection	PL	"During cooling and drying operation, compressor will stop while indoor fan will operate; During heating operation, the complete unit will stop operation."	1. The input voltage is too low; 2. The Outdoor mainboard is damaged.
26	Charging Circuit Malfunction	PU	"During cooling and drying operation, compressor will stop while indoor fan will operate; During heating operation, the complete unit will stop operation."	1. The electric reactor connection wiring is not well connected; 2. The Outdoor mainboard is damaged.

9.2 How to Check Simply the Main Part of Indoor

1. High pressure protection (E1)

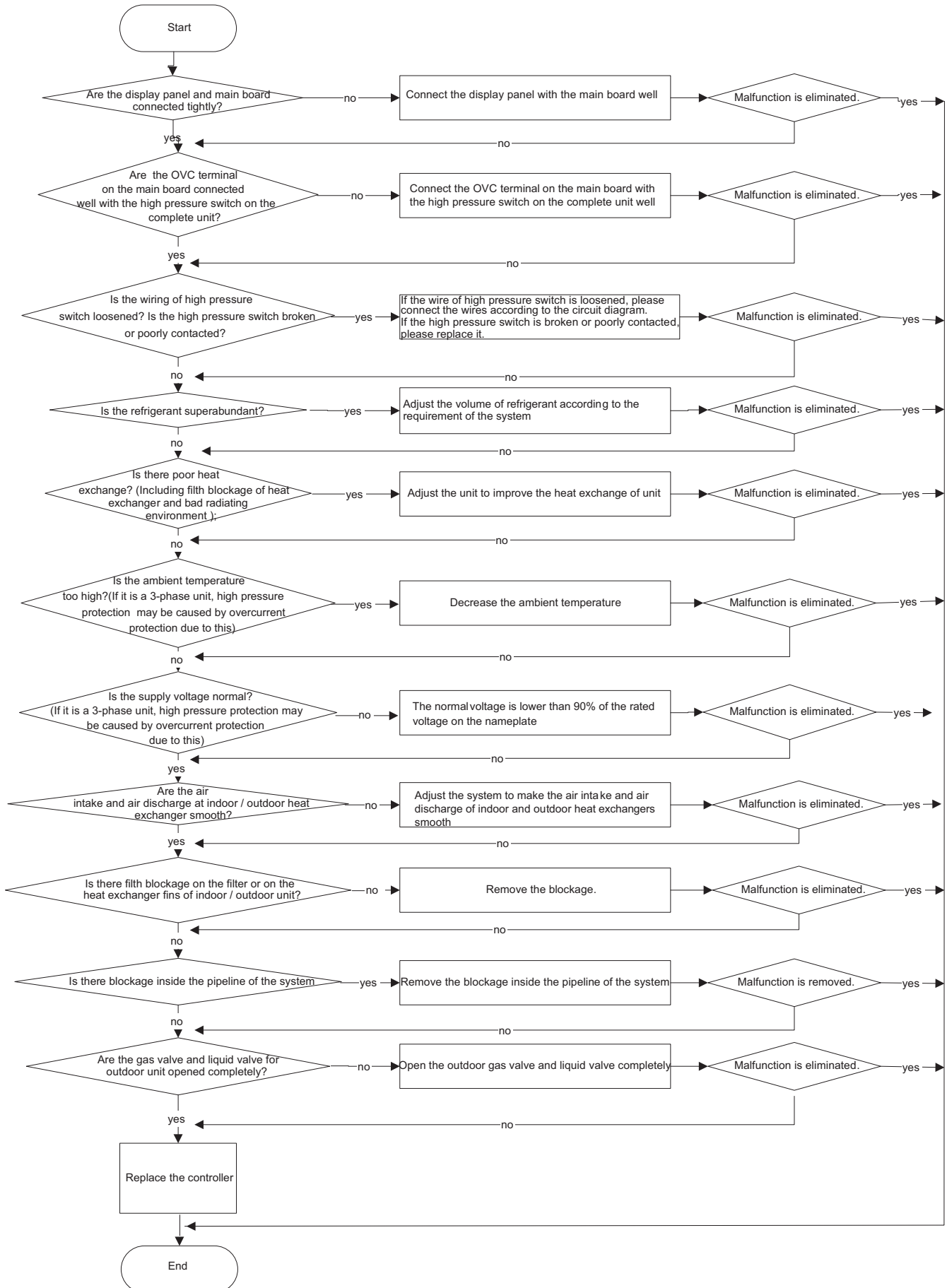

2. Freeze protection(E2)

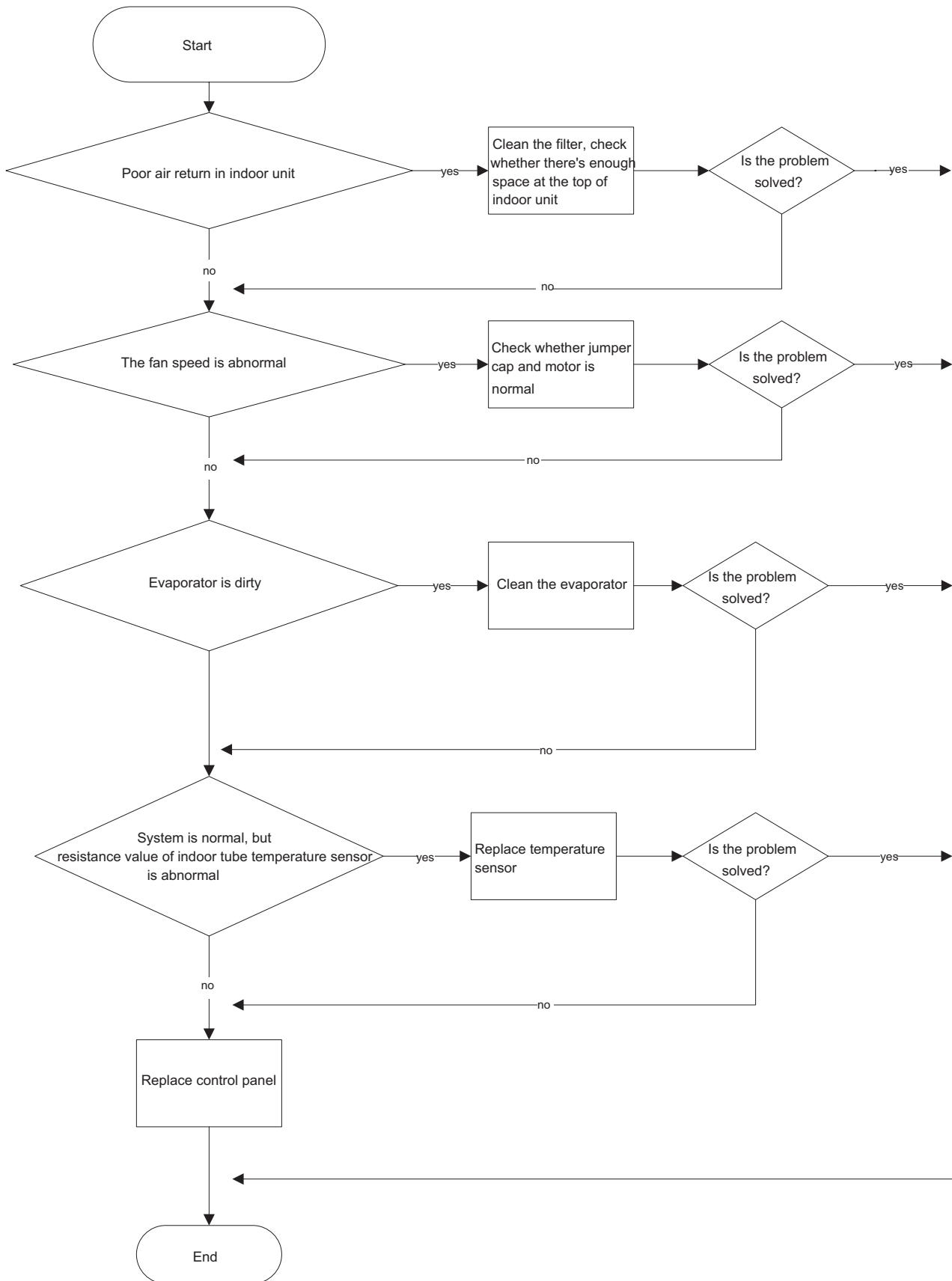

4. High discharge temperature protection of compressor (E4)

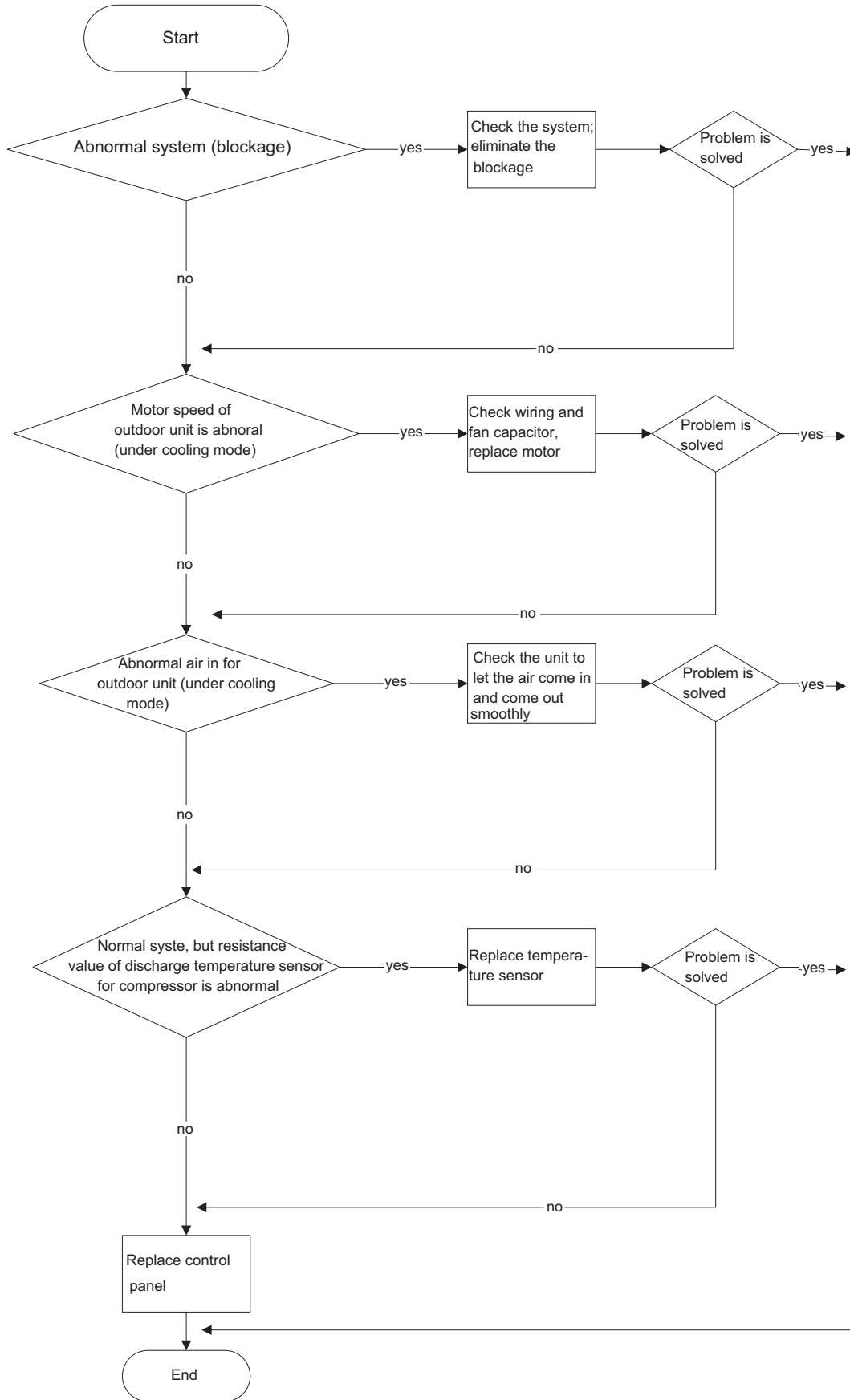

5. Overcurrent protection (E5)

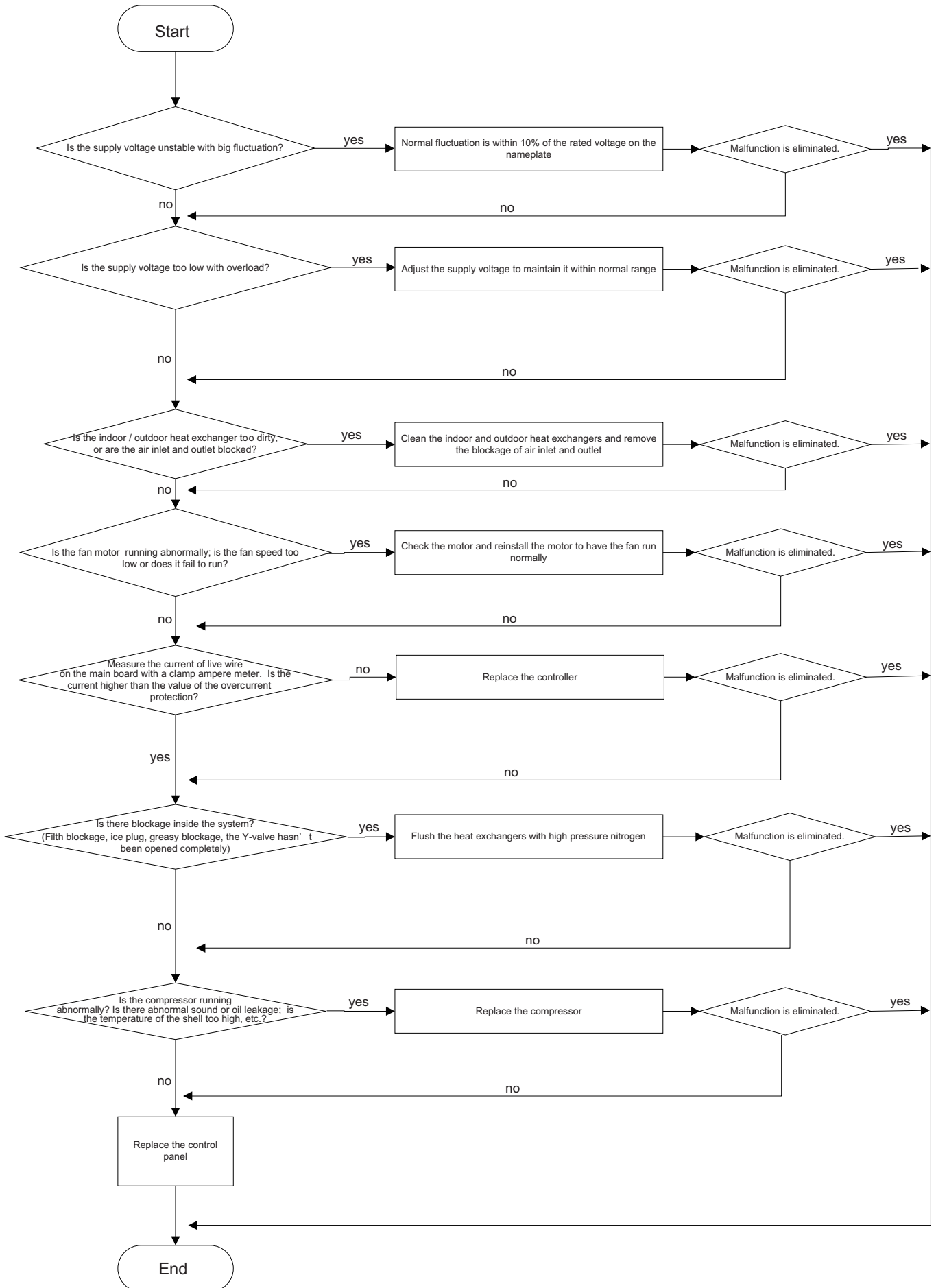

6. Malfunction of Temperature Sensor (F1, F2, F3, F4, F5)

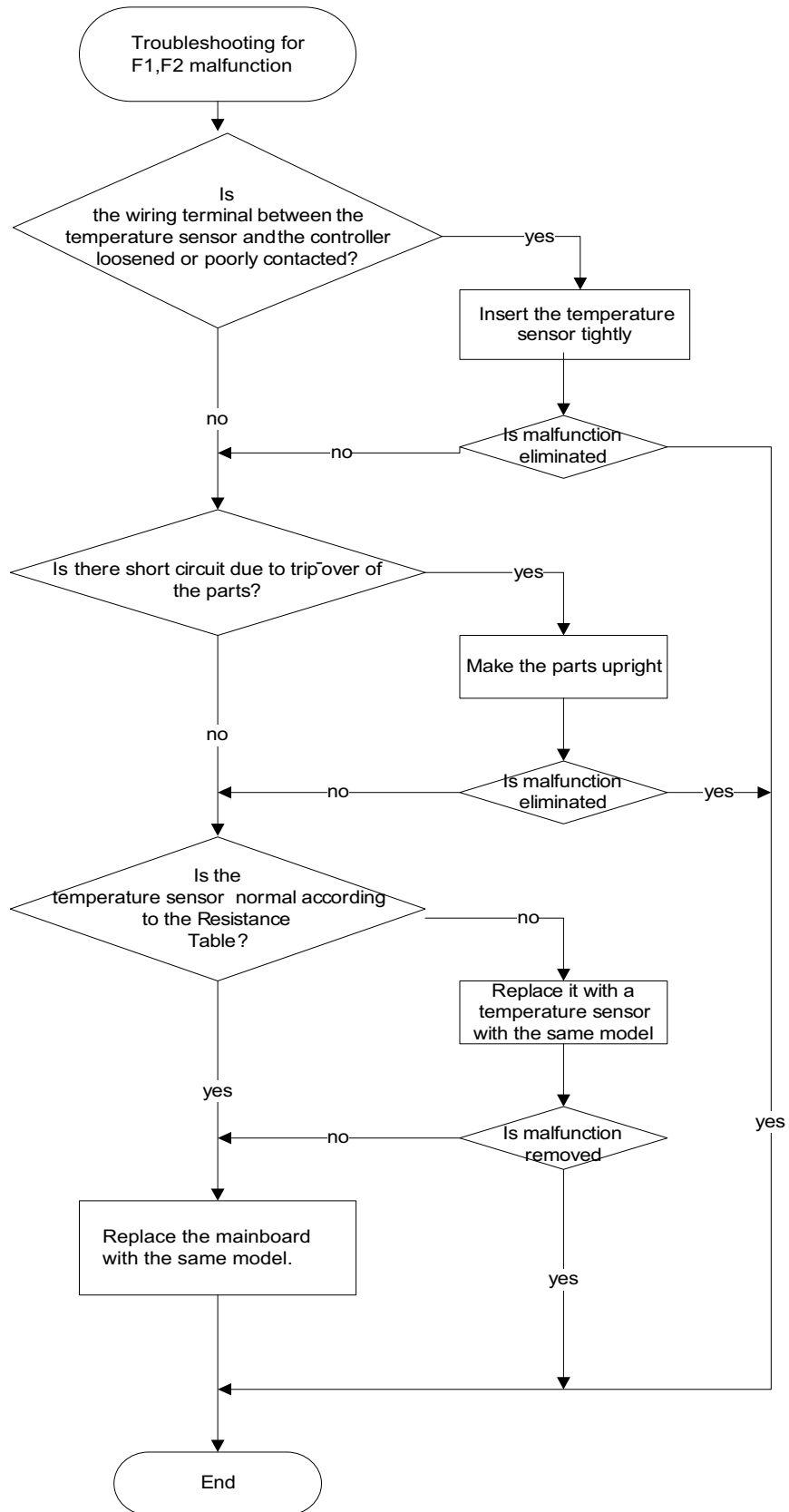

7. Communication malfunction(E6)

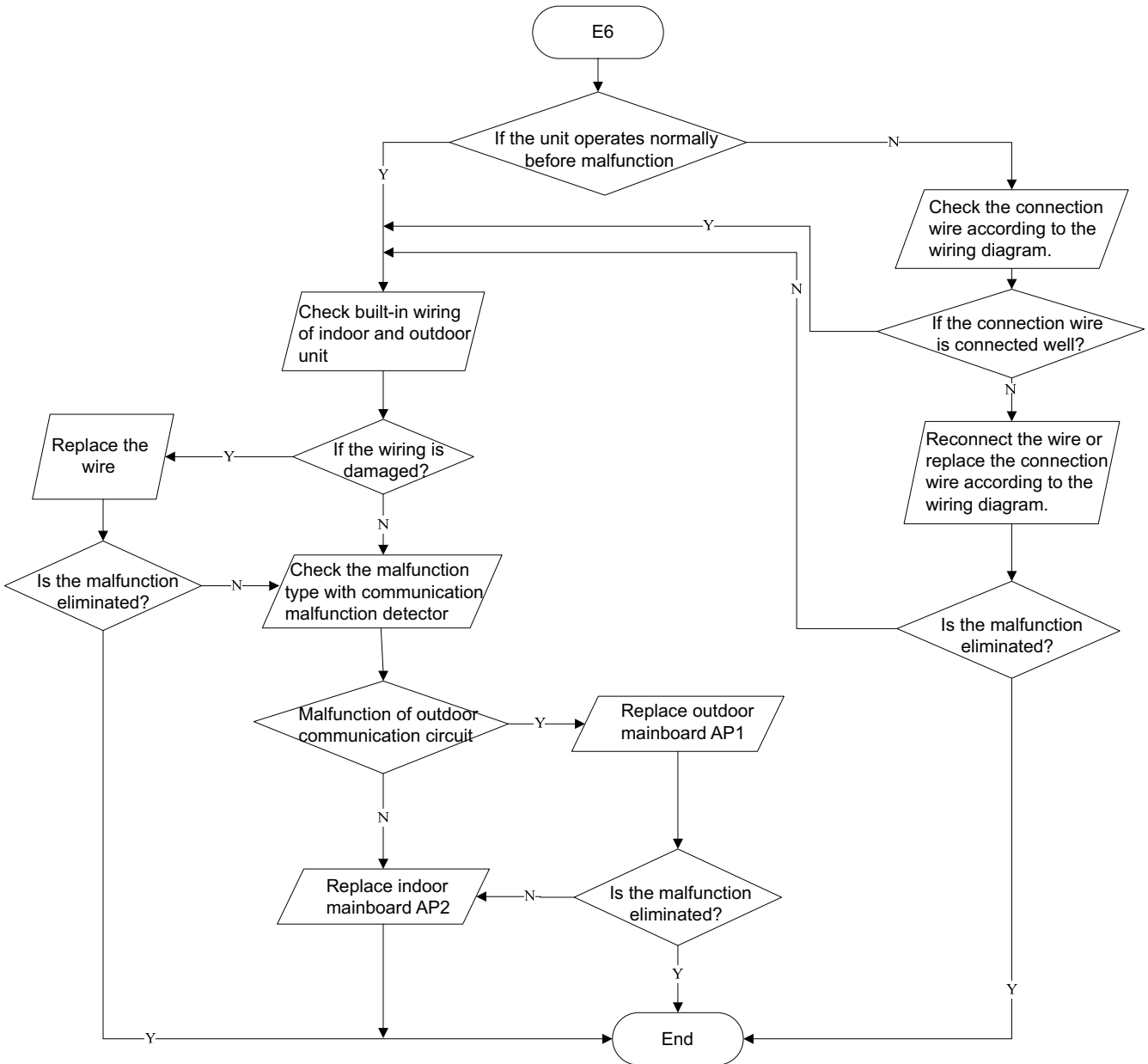

8. High temperature and overload protection (AP1 below means control board of outdoor unit) E8

Main detection points:

- If the outdoor ambient temperature is in normal range;
- If the indoor and outdoor fan are running normally;
- If the radiating environment of indoor and outdoor unit is good.

Malfunction diagnosis process:

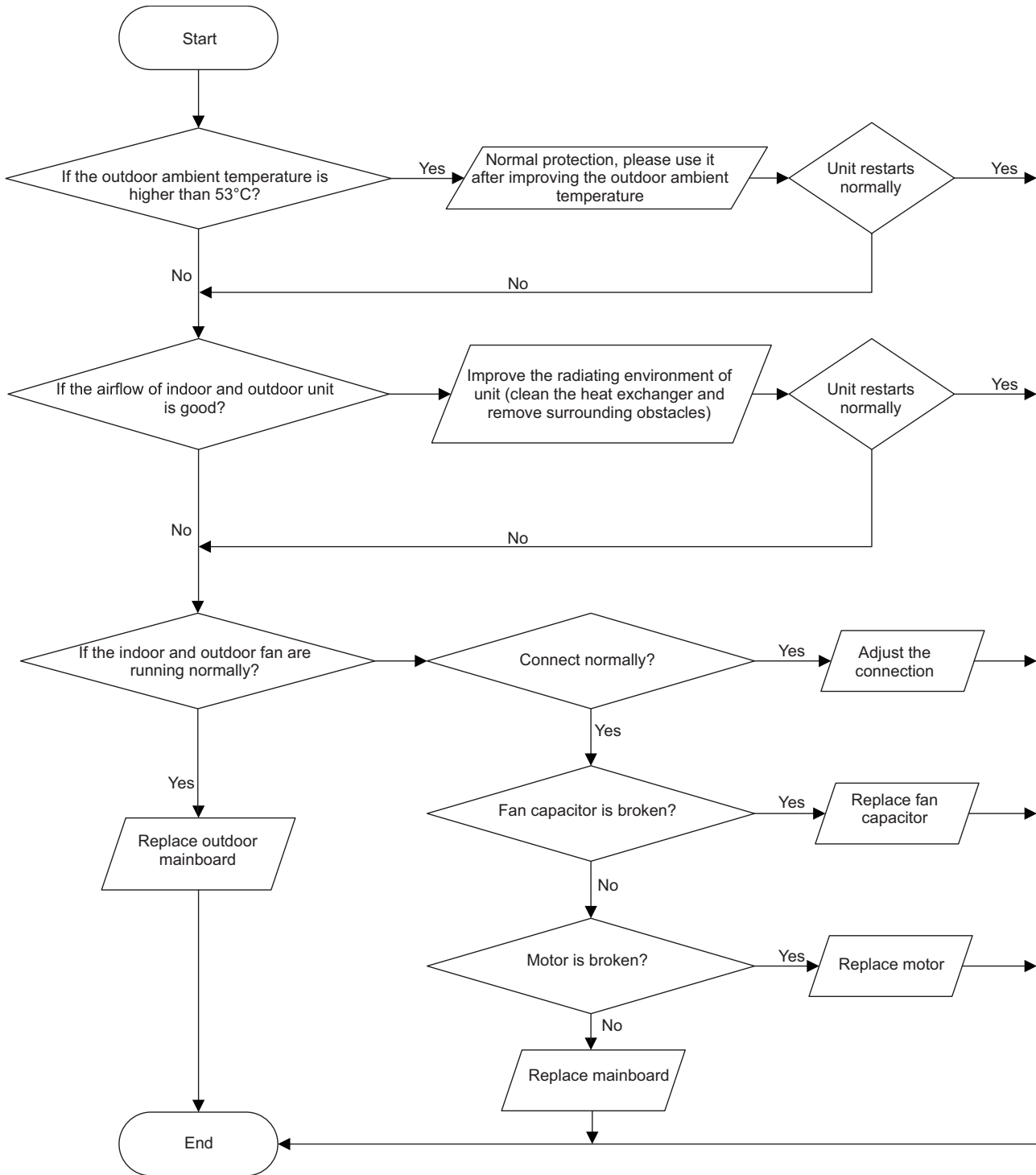

10. Malfunction of detecting plate(WIFI) JF

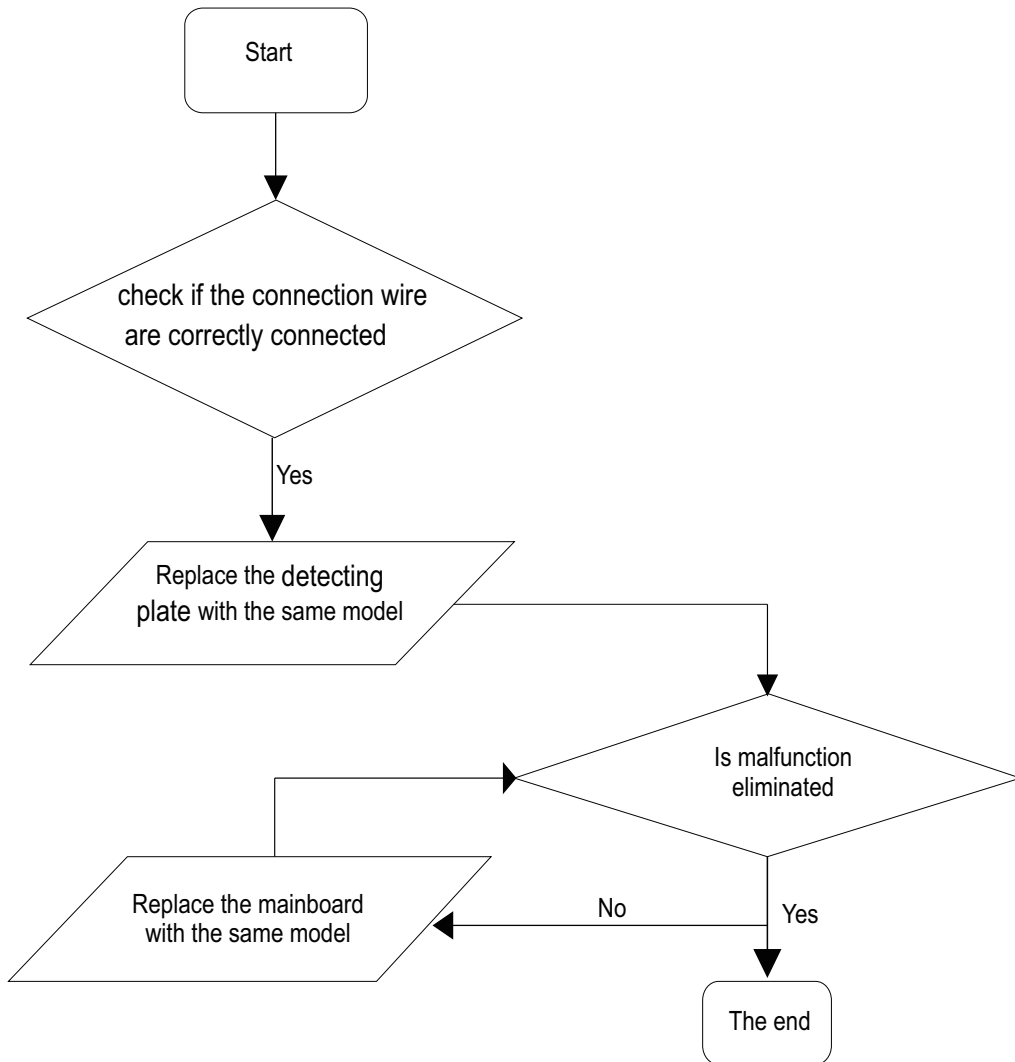

9.3 How to Check Simply the Main Part of Outdoor

1. E1: High pressure protection

Malfunction description: The pressure of ODU high pressure side is too high.

Main check points:

- Is the system pressure is normal;
- Is the pressure switch is normal;
- If above two issues are normal, the mainboard circuit is with malfunction, please replace mainboard.

2. E2: Freeze protection

Malfunction description: Too low tube temperature of IDU under cooling mode.

Main check point:

- Check if the IDU fan speed is normal, if the air inlet/outlet is smooth;
- Check if the IDU, ODU heat exchanger is too dirty that affect the heat exchanging effect.

3. E3: Low pressure protection

Malfunction description: The pressure of ODU low pressure side is too low

Main check points:

- Is the system pressure is normal;
- Is the pressure switch is normal;
- If above two issues are normal, the mainboard circuit is with malfunction, please replace mainboard.

4. E4: The air discharging temperature is too high

Main check points:

- Pull off the ODU air discharging temp. sensor, check if the temp. sensor resistance value match with present temperature;
- Check if the refrigerant is too much or too little;
- Check if the IDU, ODU heat exchanger is too dirty that affect the heat exchanging effect.

5. E6: IDU, ODU communication malfunction

Main check points:

- Check if the wiring connection if IDU and ODU is correct;
- Check if the communication power supply voltage is normal, if the DC voltage is more than $56\pm 15\%$, please replace the ODU mainboard.

6. F4: Outdoor condenser temperature sensor open or short circuit

Malfunction description: The ODU condenser temp. sensor temperature value is too high or too low that out of the normal range.

Main check points:

- Pull off the ODU condenser temp. sensor, check if the temp. sensor resistance value match with present temperature;
- If the temp. sensor resistance is normal, please replace ODU mainboard;

7. F3: ODU ambient temp. sensor open/short circuit

Malfunction description: The ODU ambient temp. sensor temperature value is too high or too low that out of the normal range.

Main check points:

- Pull off the ODU ambient temp. sensor, check if the temp. sensor resistance value match with present temperature;
- If the temp. sensor resistance is normal, please replace ODU mainboard;

8. F5: ODU air discharging temp. sensor open, short circuit

Malfunction description: The ODU air discharging temp. sensor temperature value is too high or too low that out of the normal range.

Main check points:

- Pull off the ODU air discharging temp. sensor, check if the temp. sensor resistance value match with present temperature;
- If the temp. sensor resistance is normal, please replace ODU mainboard;

9. H3: Compressor overload protection

Malfunction description: Temperature of top compressor is over than the limit value

Main check points:

- Normally the compressor overload protection switch is always on, check if the switch is normal.

10. H5: IPM module protection

Main check points:

- Check if the compressor wiring connection is well connected, if the compressor wiring sequence is correct. The correct wiring sequence is yellow, blue, red in anticlockwise direction.
- Pull off the compressor connection wire, measure the impedance between phase U/V/W and P/N, if any of them is short circuit, please replace the ODU mainboard;
- Check if the compressor is damaged, measure the resistance between any two phases of the compressor three phases.

They should be almost the same, if they're with big difference, the compressor is damaged, please check the insulation condition of three phases to the case.

11. HC: PFC protection

Main check points:

- a. Check if the unit voltage input is normal;
- b. Check if the inductance wire is well connected;
- c. If the above two issues are normal, please replace the ODU mainboard.

12. H7: Compressor out-of-step malfunction

Main check points:

- a. Check if the system pressure is too high?
- b. Check if the working voltage is too low?

13. Lc; Compressor startup failure

Main check points:

- a. Check if the compressor wiring connection is well connected;
- b. Check if the compressor startup interval is over 3 minutes, if not, please wait for 3 minutes then turn on the unit;
- c. Check if there's too much refrigerant.
- d. Check if the compressor is damaged, measure the resistance between any two phase of the three phases, they should be almost the same, if they're with big difference, the compressor is damaged, please check the insulation condition of three phases to the case.

14. PU: ODU capacitor charging malfunction

Malfunction description: after the unit is energized, before the compressor starting operation, the electrolytic capacitor on mainboard should be charging. After the charging command is received, if it is detected by chip that the voltage of electrolytic capacitor is low, it is ODU capacitor charging malfunction.

Main check points:

- a. Check if the unit voltage input is within normal range.
- b. Check if the electric reactor connection wiring and capacitor connection wiring is well connected, if the electric reactor is open circuit.
- c. If above two issues are normal, please replace ODU mainboard.

15. P7: Module temp. sensor circuit malfunction

Malfunction description: There's a thermal resistance on top of IPM module, for detecting the module surface temperature, if it is detected by chip that the temperature is over the normal range.

Main check points:

- a. The circuit on mainboard is damaged, please replace the ODU mainboard.

16. P8: Module temperature too high protection

Main check points:

- a. After daubing radiating glue on IPM module, fix it with screw, if the glue is aging or the fixing screw is loosened, please daub the glue again or fix the screw and test again, if the malfunction still exist, please replace the mainboard.

17. PH: ODU DC bus bar voltage too high

Malfunction description: When it is detected the voltage of DC bus bar on electrolytic capacitor is over 420V.

Main check points:

- a. Check if the input voltage is too high that out of normal power supply voltage range.

18. PL: ODU DC bus bar voltage too low

Malfunction description: When it is detected the voltage of DC bus bar on electrolytic capacitor is less than 200V.

Main check points:

- a. Check if the input voltage is too low that out of normal power supply voltage range.

19. PU: Charging circuit malfunction

Malfunction description: The DC bus bar voltage is less than 100V during charging.

Main check points: Check if the circuit wiring connection is loosened or correct as wiring diagram, well connect the wire, if the malfunction still exist, please replace the mainboard.

9.4 Maintenance Method for Normal Malfunction

1. Air Conditioner Can't be Started Up

Possible Causes	Discriminating Method (Air conditioner Status)	Troubleshooting
No power supply, or poor connection for power plug	After energization, operation indicator isn't bright and the buzzer can't give out sound	Confirm whether it's due to power failure. If yes, wait for power recovery. If not, check power supply circuit and make sure the power plug is connected well.
Wrong wire connection between indoor unit and outdoor unit, or poor connection for wiring terminals	Under normal power supply circumstances, operation indicator isn't bright after energization	Check the circuit according to circuit diagram and connect wires correctly. Make sure all wiring terminals are connected firmly
Electric leakage for air conditioner	After energization, room circuit breaker trips off at once	Make sure the air conditioner is grounded reliably Make sure wires of air conditioner is connected correctly Check the wiring inside air conditioner. Check whether the insulation layer of power cord is damaged; if yes, place the power cord.
Model selection for air switch is improper	After energization, air switch trips off	Select proper air switch
Malfunction of remote controller	After energization, operation indicator is bright, while no display on remote controller or buttons have no action.	Replace batteries for remote controller Repair or replace remote controller

2. Poor Cooling (Heating) for Air Conditioner

Possible Causes	Discriminating Method (Air conditioner Status)	Troubleshooting
Set temperature is improper	Observe the set temperature on remote controller	Adjust the set temperature
Rotation speed of the IDU fan motor is set too low	Small wind blow	Set the fan speed at high or medium
Filter of indoor unit is blocked	Check the filter to see it's blocked	Clean the filter
Installation position for indoor unit and outdoor unit is improper	Check whether the installation position is proper according to installation requirement for air conditioner	Adjust the installation position, and install the rainproof and sunproof for outdoor unit
Refrigerant is leaking	Discharged air temperature during cooling is higher than normal discharged wind temperature; Discharged air temperature during heating is lower than normal discharged wind temperature; Unit's pressure is much lower than regulated range	Find out the leakage causes and deal with it. Add refrigerant.
Malfunction of 4-way valve	Blow cold wind during heating	Replace the 4-way valve
Malfunction of capillary	Discharged air temperature during cooling is higher than normal discharged wind temperature; Discharged air temperature during heating is lower than normal discharged wind temperature; Unit's pressure is much lower than regulated range. If refrigerant isn't leaking, part of capillary is blocked	Replace the capillary
Flow volume of valve is insufficient	The pressure of valves is much lower than that stated in the specification	Open the valve completely
Malfunction of horizontal louver	Horizontal louver can't swing	Refer to point 3 of maintenance method for details
Malfunction of the IDU fan motor	The IDU fan motor can't operate	Refer to troubleshooting for H6 for maintenance method in details
Malfunction of the ODU fan motor	The ODU fan motor can't operate	Refer to point 4 of maintenance method for details
Malfunction of compressor	Compressor can't operate	Refer to point 5 of maintenance method for details

3. Horizontal Louver Can't Swing

Possible Causes	Discriminating Method (Air conditioner Status)	Troubleshooting
Wrong wire connection, or poor connection	Check the wiring status according to circuit diagram	Connect wires according to wiring diagram to make sure all wiring terminals are connected firmly
Stepping motor is damaged	Stepping motor can't operate	Repair or replace stepping motor
Main board is damaged	Others are all normal, while horizontal louver can't operate	Replace the main board with the same model

4. ODU Fan Motor Can't Operate

Possible causes	Discriminating method (air conditioner status)	Troubleshooting
Wrong wire connection, or poor connection	Check the wiring status according to circuit diagram	Connect wires according to wiring diagram to make sure all wiring terminals are connected firmly
Capacity of the ODU fan motor is damaged	Measure the capacity of fan capacitor with an universal meter and find that the capacity is out of the deviation range indicated on the nameplate of fan capacitor.	Replace the capacity of fan
Power voltage is a little low or high	Use universal meter to measure the power supply voltage. The voltage is a little high or low	Suggest to equip with voltage regulator
Motor of outdoor unit is damaged	When unit is on, cooling/heating performance is bad and ODU compressor generates a lot of noise and heat.	Change compressor oil and refrigerant. If no better, replace the compressor with a new one

5. Compressor Can't Operate

Possible causes	Discriminating method (air conditioner status)	Troubleshooting
Wrong wire connection, or poor connection	Check the wiring status according to circuit diagram	Connect wires according to wiring diagram to make sure all wiring terminals are connected firmly
Capacity of compressor is damaged	Measure the capacity of fan capacitor with an universal meter and find that the capacity is out of the deviation range indicated on the nameplate of fan capacitor.	Replace the compressor capacitor
Power voltage is a little low or high	Use universal meter to measure the power supply voltage. The voltage is a little high or low	Suggest to equip with voltage regulator
Coil of compressor is burnt out	Use universal meter to measure the resistance between compressor terminals and it's 0	Repair or replace compressor
Cylinder of compressor is blocked	Compressor can't operate	Repair or replace compressor

6. Air Conditioner is Leaking

Possible causes	Discriminating method (air conditioner status)	Troubleshooting
Drain pipe is blocked	Water leaking from indoor unit	Eliminate the foreign objects inside the drain pipe
Drain pipe is broken	Water leaking from drain pipe	Replace drain pipe
Wrapping is not tight	Water leaking from the pipe connection place of indoor unit	Wrap it again and bundle it tightly

7. Abnormal Sound and Vibration

Possible causes	Discriminating method (air conditioner status)	Troubleshooting
When turn on or turn off the unit, the panel and other parts will expand and there's abnormal sound	There's the sound of "PAPA"	Normal phenomenon. Abnormal sound will disappear after a few minutes.
When turn on or turn off the unit, there's abnormal sound due to flow of refrigerant inside air conditioner	Water-running sound can be heard	Normal phenomenon. Abnormal sound will disappear after a few minutes.
Foreign objects inside the indoor unit or there're parts touching together inside the indoor unit	There's abnormal sound fro indoor unit	Remove foreign objects. Adjust all parts' position of indoor unit, tighten screws and stick damping plaster between connected parts
Foreign objects inside the outdoor unit or there're parts touching together inside the outdoor unit	There's abnormal sound fro outdoor unit	Remove foreign objects. Adjust all parts' position of outdoor unit, tighten screws and stick damping plaster between connected parts
Short circuit inside the magnetic coil	During heating, the way valve has abnormal electromagnetic sound	Replace magnetic coil
Abnormal shake of compressor	Outdoor unit gives out abnormal sound	Adjust the support foot mat of compressor, tighten the bolts
Abnormal sound inside the compressor	Abnormal sound inside the compressor	If add too much refrigerant during maintenance, please reduce refrigerant properly. Replace compressor for other circumstances.

10. Exploded View and Parts List

10.1 Indoor Unit

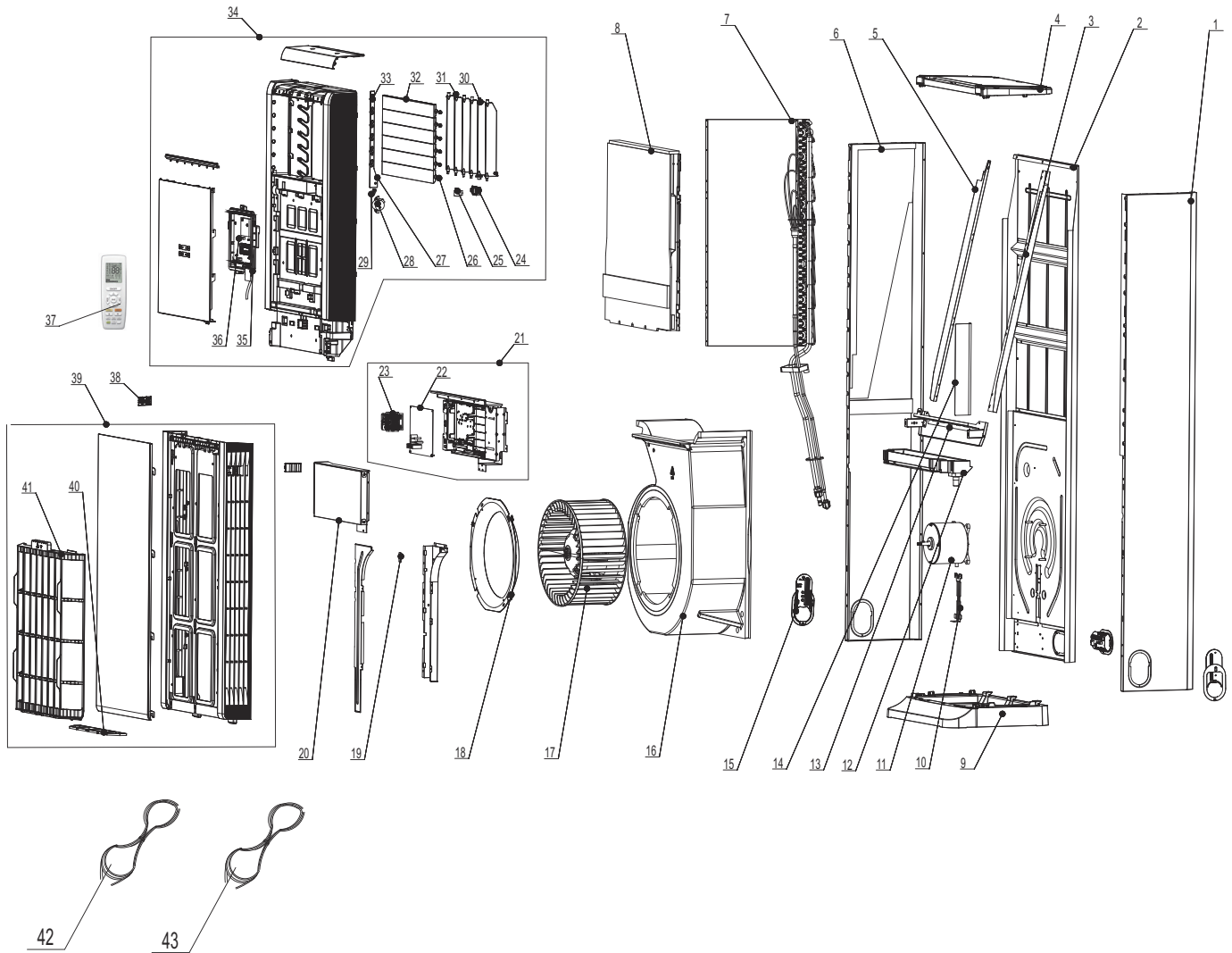

The component picture is only for reference; please refer to the actual product.

NO.	Description	Part Code	Qty
		AST-48BI	
1	Right Side Plate Sub-Assy	0130451801	1
2	Rear Plate Sub-Assy	01304290	1
3	Right Air Guard	01364507	1
4	Top Cover Sub-Assy	000051000034	1
5	Left Air Guard	01364506	1
6	Left Side Plate Sub-Assy	0130451901	1
7	Evaporator Assy	01100100275	1
8	Air Guard Assy	01364509	1
9	Chassis	200148000005	1
10	Wire Clamp	01384201	1
11	Fan Motor	150104060057	1
12	Water Tray Sub-Assy	12314811	1
13	Breakwater Sub-Assy	01364154P	1
14	Protection Cover	20124062	1
15	Remote Control Panel Sub-assy	20903400001	3
16	Propeller Housing Sub-assy	12104058	1
17	Centrifugal Fan	10314401	1
18	Diversion Circle	10374435	1
19	Gasket	70414201	1
20	Electric Box Cover Sub-Assy	01404388	1
21	Electric Box Assy	100002069209	1
22	Main Board	300002061447	1
23	Terminal Board	422000060016	1
24	Motor Cover	22244170	1
25	Stepping Motor	1521210104	1
26	Air Guide Bushing	1054420302	6
27	Guide Blade Lever	200235000004	1
28	Stepping Motor	15212115	1
29	Crank 1	10564204	1
30	Air Louver 1	200007000028	1
31	Air Louver 2	200007000029	5
32	Guide Louver	200004000023	6
33	Crankshaft of Guide Louver	1056420502	6
34	Air Outlet Panel Assy	000039000017	1
35	Display Sub-Assy	000057000046	1
36	Display Board	300001000195	1
37	Remote Controller	305001000125	1
38	Screw Cover	200005000006	2
39	Air Intake Panel Assy	209006000002	1
40	Filter (lower)	11124012	1
41	Filter Sub-assy(Upper)	111001000032	1
42	Connecting Cable	4002052319	1
43	Connecting Cable	4002054015	1

Above data is subject to change without notice.

NO.	Description	Part Code	Qty
		AST-48BI/O	
1	Front Grill	01572800003	1
2	Cabinet	012022000003	1
3	Diversion Circle	10474100003	1
4	Axial Flow Fan	1043410000801	1
5	Handle	2690410001603	1
6	Front Side Plate	012050060025	1
7	Drainage hole Cap	76715005	3
8	Drainage Joint	26113009	1
9	Compressor and Fittings	009001060077	1
10	Motor Support Sub-Assy	017012060034	1
11	Motor Support	012048060023	1
12	Brushless DC Motor	150104060013	1
13	4-Way Valve Assy	030152060598	1
14	Pressure Protect Switch	46020007	1
15	Pressure Protect Switch	4602000603	1
16	Valve Support Sub-Assy	01805200222	1
17	Cut-off valve 5/8	07103030	1
18	Cut off Valve 3/8	07130209	1
19	Valve cover	22245005	1
20	Rear Side Plate	012076060341	1
21	Handle	26235001	1
22	Electric Expand Valve Fitting	072002060023	1
23	Electric Expansion Valve Sub-Assy	030174060119	1
24	Chassis Sub-assy	017000060533	1
25	Clapboard	012051060978	1
26	Condenser Assy	011002061114	1
27	Rear Grill	01574100014	1
28	Wiring bracket	012060067477	1
29	Terminal Board	422000060016	1
30	Terminal Board	422000060003	1
31	Electric Box Assy	100002070276	1
32	Coping	01264100052	1
33	Electric Box Cover	012020060532	1
34	Electric Box Sub-Assy	017007062252	1
35	Mounting Plate	200139060032	1
36	Main Board	300027060925	1
37	Electric Component Mounting Plate	012064061065	1
38	Mounting Plate	200139060031	1
39	Filter Board	300020060064	1
40	Radiator	430034060083	1
41	Cover of Reactor Box	012120060010	1
42	Left Side Plate	012055000007	1
43	PFC Inductance	34003206000402	1/3
44	Reactor Box	012119060019	1
	Air Outlet Panel Assy	000039000017	1
	Air Intake Panel Assy	000041060059	1
	4-way Valve body	4300008201	1
	4-way Valve coil	4300040045	1

Above data is subject to change without notice.

11. Removal Procedure

⚠ Caution: discharge the refrigerant completely before removal.

11.1 Removal Procedure of Indoor Unit

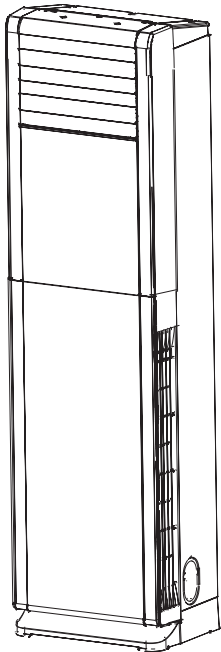
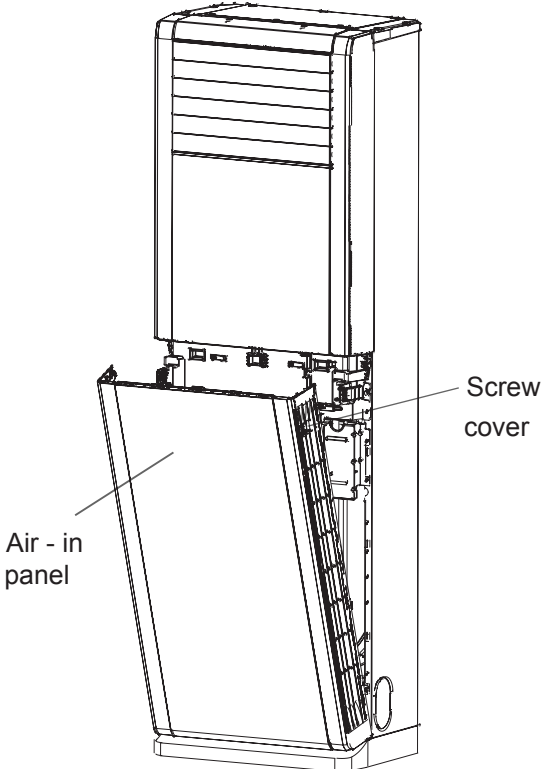
Step	Procedure
1. Outside view of indoor unit	
2. Remove air-in panel	<p data-bbox="204 1268 672 1406">Open the screw cover, use screwdriver to remove screws used for fixing the air-in panel at both sides, and then remove the air-in panel.</p> 

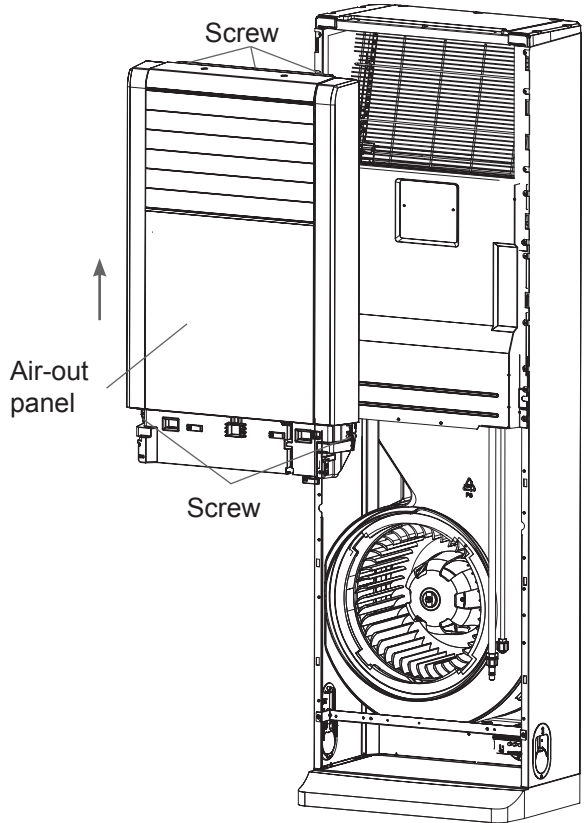
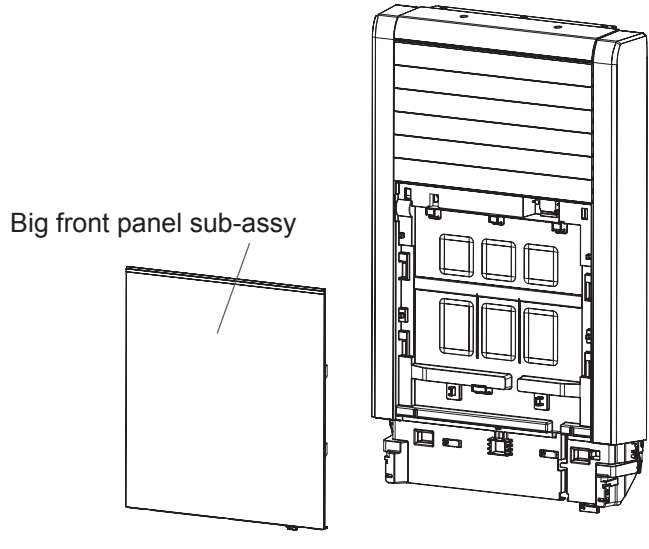
Step	Procedure
<p>5.Remove air-out panel</p>	<p>Remove 3 screws at the top part of the air-out panel, 2 screw at the lower part and screws under the screw cover, push the air-output panel upwards slightly and then remove the air-output panel.</p> 
<p>6.Remove big front panel sub-assy</p>	<p>Remove 2 screws at the lower part, and then pull the big front panel sub-assy downwards slightly to remove it.</p> 

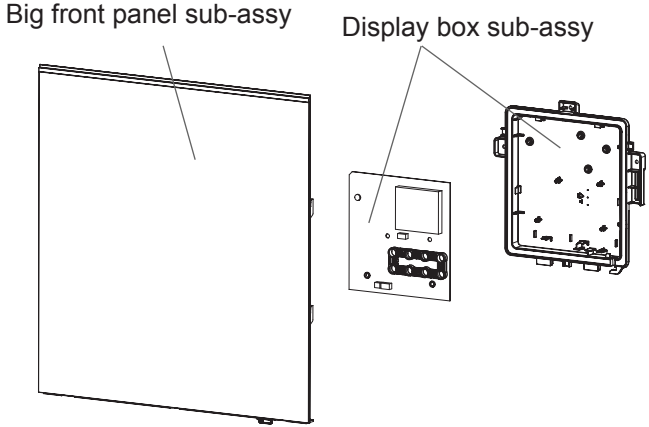
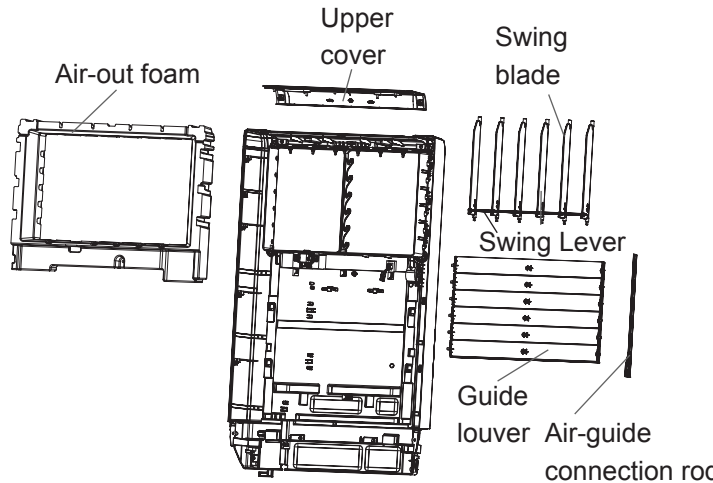
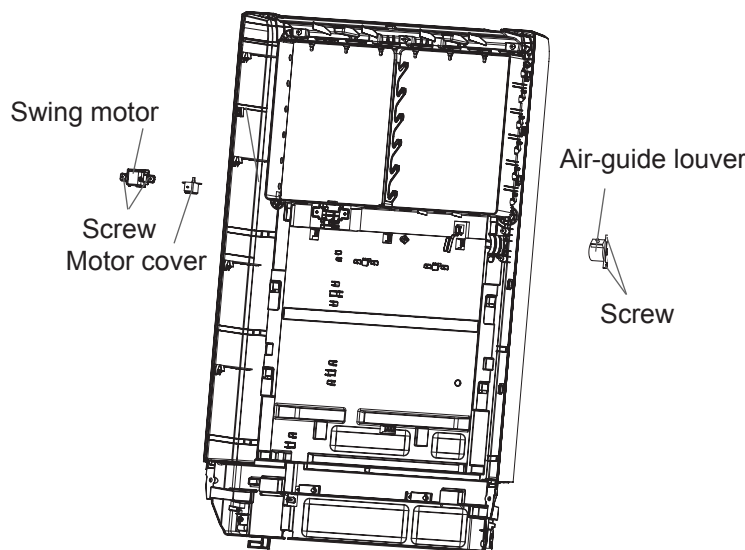
Step	Procedure	Diagram
7.Remove display box	<p>Take out the display connection wire from the wire groove, remove 2 screw at the back of the display cover and then remove the display cover sub-assy.</p>	 <p>The diagram shows two components: a large rectangular 'Big front panel sub-assy' and a smaller 'Display box sub-assy' which includes a display screen and a control panel.</p>
8.Remove upper cover, air-outlet foam, guide louver, swing blade	<p>a Hold both end of the foam, and then remove the air-outlet foam;</p> <p>b Remove 2 screws at the upper part of the upper cover and 2 screws at the back side, and then the upper cover can be removed.</p> <p>c Remove the air-guide connection rod and then pull the guide louver outwards to remove it.</p> <p>d When the swing connection rod is removed, pull the swing blade outwards to remove it.</p>	 <p>The diagram illustrates the disassembly of the upper section. It shows the 'Air-out foam' being removed from the 'Upper cover'. The 'Swing blade' is shown being pulled away from the 'Swing Lever'. The 'Guide louver' and 'Air-guide connection rod' are also shown being removed from the main chassis.</p>
9.Remove swing motor and air-guide motor	<p>a Remove screws used for fixing the air guide motor, and then the air guide motor can be removed.</p> <p>b Remove screws used for fixing the motor cover, remove the motor cover and then the swing motor can be removed.</p>	 <p>The diagram shows the internal chassis with the 'Swing motor' and 'Air-guide louver' being removed. Individual parts like a 'Screw' and 'Motor cover' are also shown.</p>

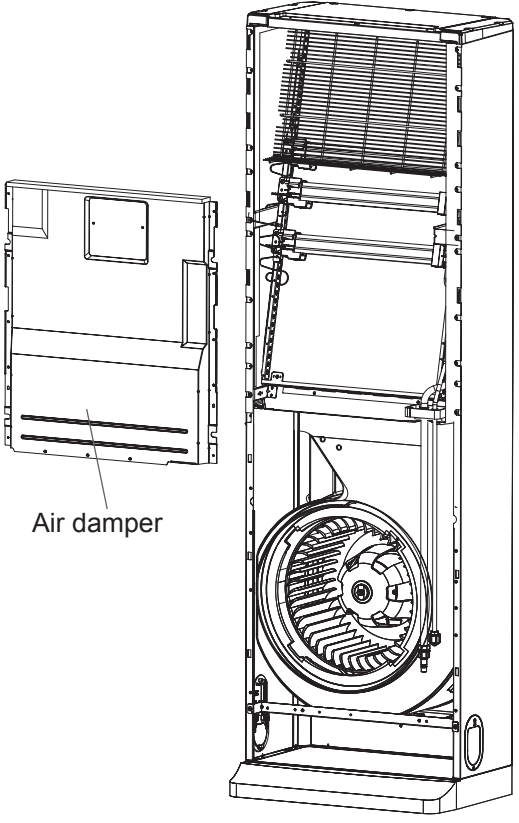
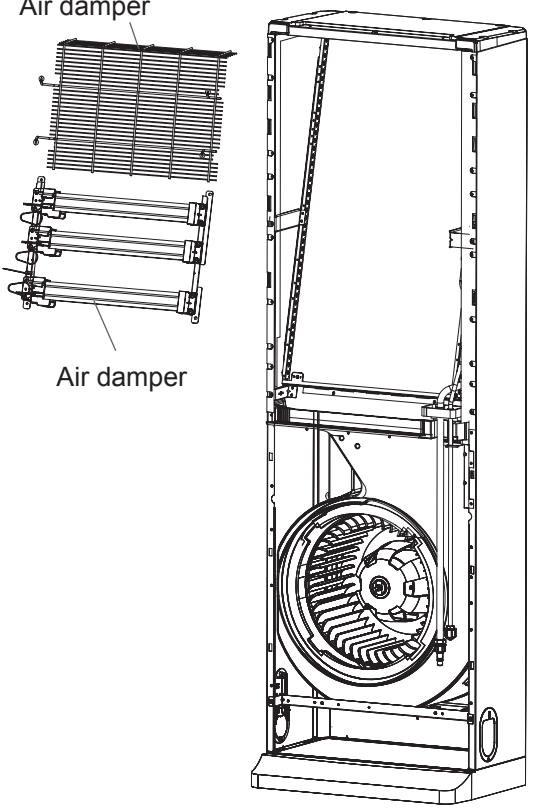
Step	Procedure
<p>10.Remove air damper</p>	<p>Remove 10 screws used for fixing the air damper, and then the air damper can be removed.</p> 
<p>11.Remove electric heating part</p>	<p>Remove 4 screws on the protective grille and then remove the protective grille; Remove 4 screws on the electric heating part and then remove the electric heating part.</p> 

Step	Procedure	
<p>14. Remove propeller housing, centrifugal blade and motor</p> <p>a Remove 3 screws used for fixing the press plate of propeller housing and then remove the press plate of propeller housing;</p> <p>b Rotate the guide loop to a certain position along the clockwise direction, and then remove the guide loop;</p> <p>c Remove 9 screws used for fixing the propeller housing, and then remove the propeller housing;</p> <p>d Use wrench to twist off the nuts used for fixing the centrifugal chiller and then pull the centrifugal blade outwards;</p> <p>e Remove the centrifugal blade;</p> <p>f Remove 4 nuts used for fixing the motor and 2 screws used for fixing the wire-pressing plate, and then remove the motor.</p>		
<p>15. Remove chassis</p>	<p>After 9 screws are removed, pull the chassis downwards to remove it.</p>	

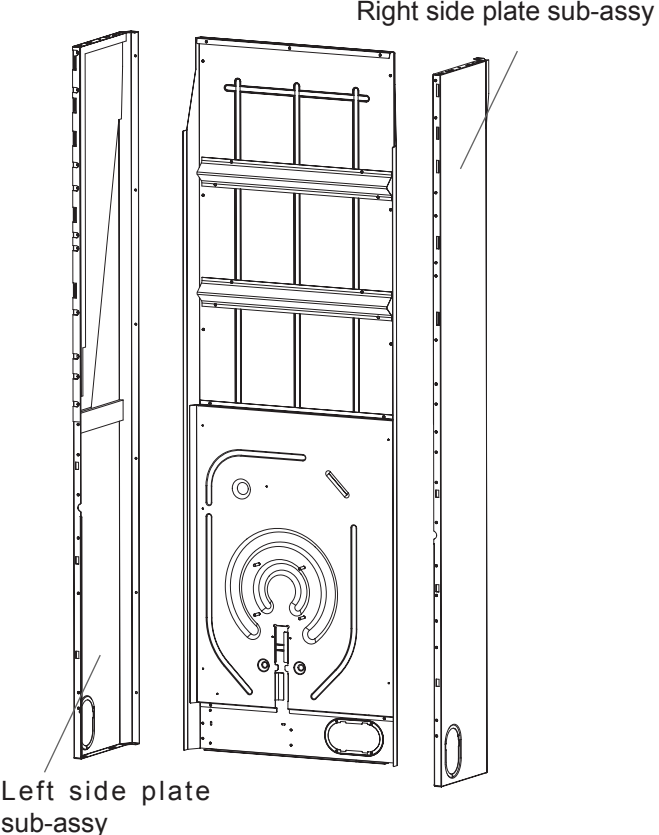
Step	Procedure
16.Remove left and right side plate sub-assys	<p data-bbox="196 347 618 476">Remove screws at both sides, pull them to both sides respectively and then left and right plate sub-assys can be removed.</p>  <p data-bbox="1198 301 1502 329">Right side plate sub-assy</p> <p data-bbox="841 1072 1052 1131">Left side plate sub-assy</p>

11.2 Removal Procedure of Outdoor Unit



Warning

Be sure to wait for a minimum of 10 minutes after turning off all power supplies before disassembly.

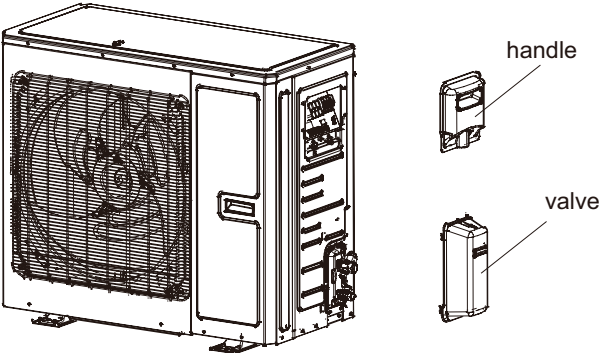
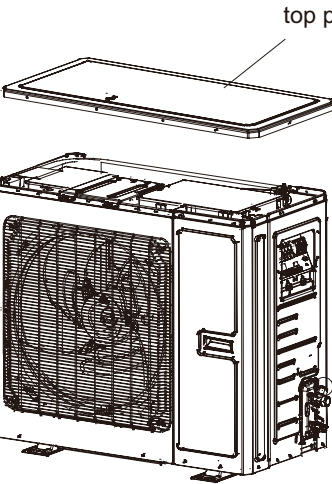
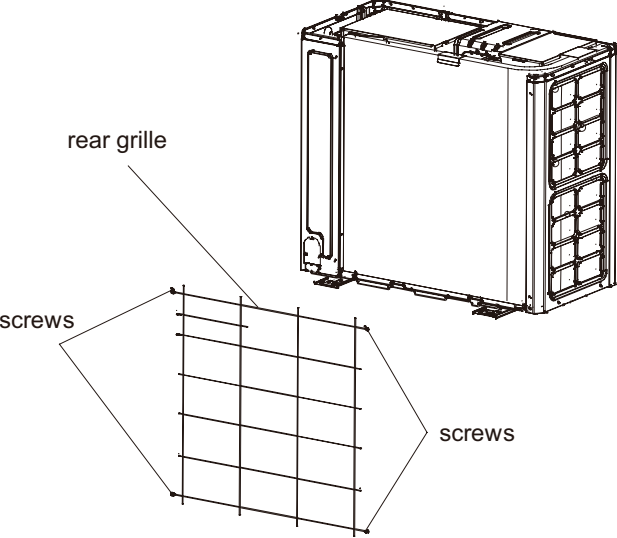
Steps	Procedure
<p>1. Remove big handle, valve cover and top cover</p>	<p>Remove the screw connecting the big handle and right side plate, and then remove the big handle. Remove the screw connecting the valve cover and right side plate, and then remove the valve cover</p> <p>Remove the screws connecting the top cover with outer case, right side plate and left side plate; lift the top cover upwards to remove it</p>  
<p>2. Remove the rear grille</p>	<p>Remove the tapping screws connecting the back grille with the back-side plate, the front case and the chassis. Remove the back grille.</p> 

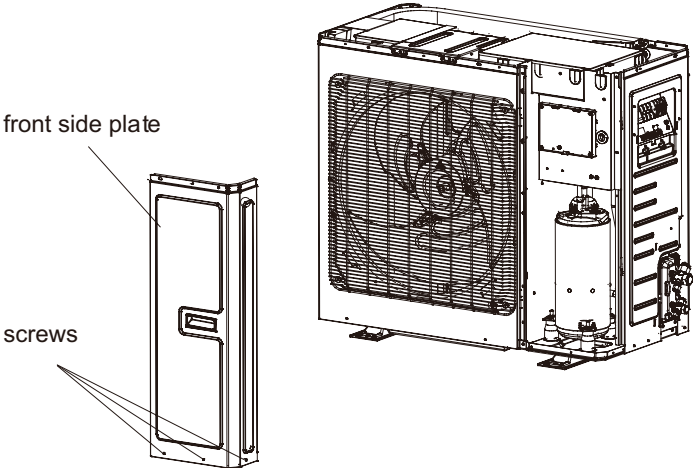
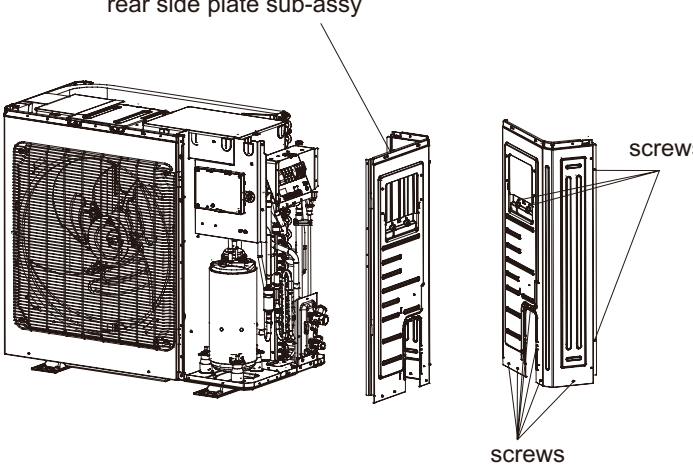
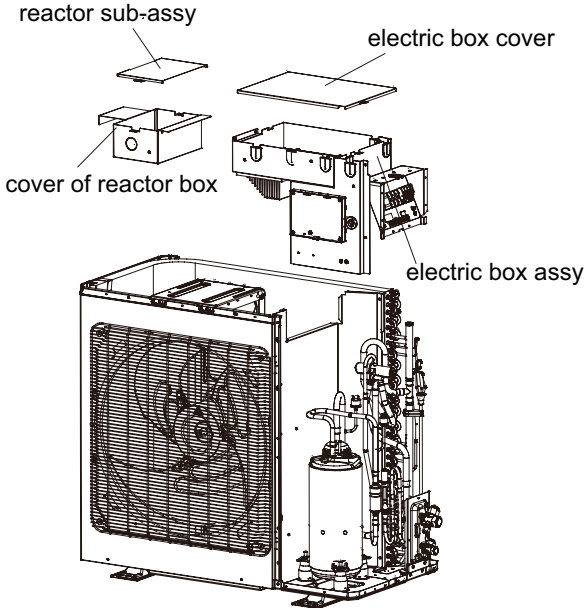
Steps	Procedure
3. Remove the front side plate	<p data-bbox="207 373 639 482">Remove the 2 tapping screws fixing the front side plate. Take the front side plate outward to remove it.</p>  <p data-bbox="816 388 976 410">front side plate</p> <p data-bbox="816 602 894 624">screws</p>
4. Remove the rear side plate sub-assy	<p data-bbox="207 952 748 1039">Remove the screws connecting the rear side plate sub-assy and then remove the rear side plate sub-assy .</p>  <p data-bbox="922 869 1179 891">rear side plate sub-assy</p> <p data-bbox="1304 1316 1382 1338">screws</p>
5. Remove the electric box assy and electric box cover	<p data-bbox="207 1552 769 1869"> a. Open the screws fixing the electric box cover and then remove the electric box cover. b. Disconnect the connection wire of motor, compressor, temperature sensor and PFC inductor; remove the ground wire screw in the wiring board and the screws fixing the electric box, and then remove the electric box assy. c. Remove the screws fixing the electric box cover and then remove the electric box cover. d. Disconnect the connection wire of PFC inductor and then remove the reactor box sub-assy. </p>  <p data-bbox="894 1399 1073 1421">reactor sub-assy</p> <p data-bbox="1243 1421 1438 1443">electric box cover</p> <p data-bbox="878 1568 1097 1589">cover of reactor box</p> <p data-bbox="1276 1655 1463 1677">electric box assy</p>

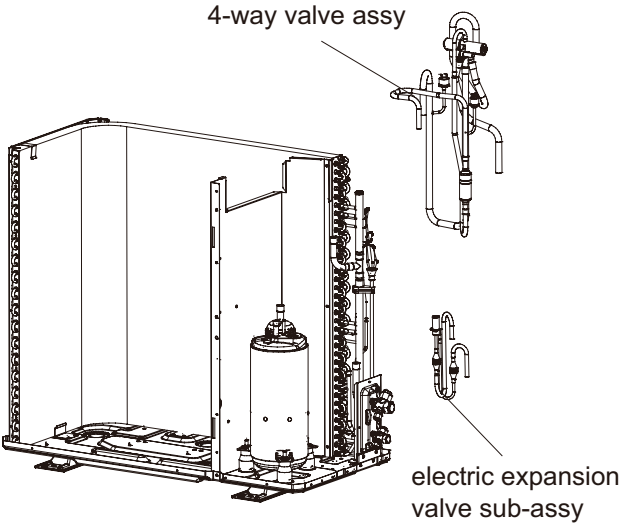
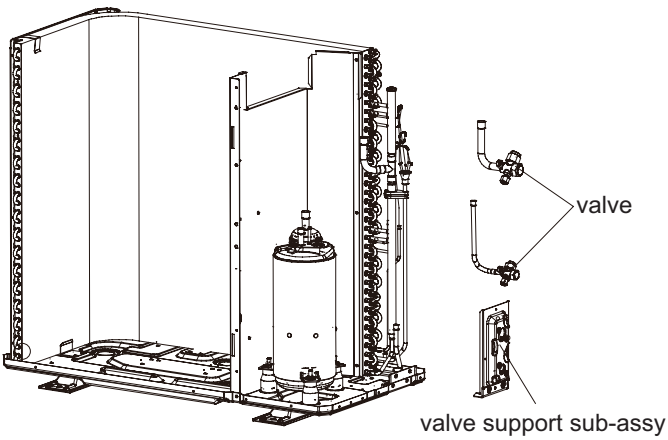
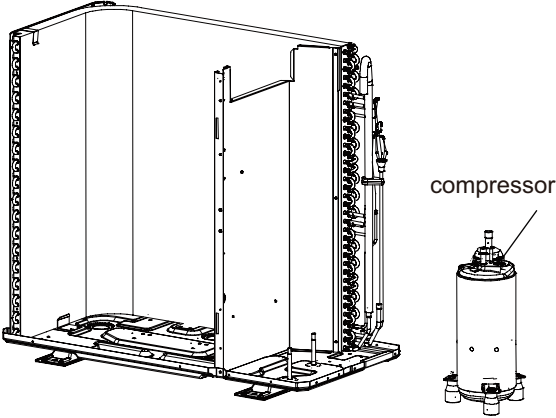
Steps	Procedure
9. Remove 4-way valve assy and electric expansion valve sub-assy	<p data-bbox="225 329 792 576">Unsolder the welding joints connecting the 4-way valve assy with electric expansion valvesub-assy, compressor and condenser; remove the 4-way valve. Note: Before unsoldering the welding joint, wrap the 4-way valve with a wet cloth completely to avoid damage to the valve caused by high temperature.</p>  <p data-bbox="1052 257 1252 286">4-way valve assy</p> <p data-bbox="1256 716 1469 781">electric expansion valve sub-assy</p>
10. Remove valve support sub-assy	<p data-bbox="225 984 792 1072">Twist off the screws connecting valve support sub-assy and chassis and then remove the valve support sub-assy.</p>  <p data-bbox="1419 1100 1479 1129">valve</p> <p data-bbox="1263 1319 1516 1347">valve support sub-assy</p>
11. Remove compressor	<p data-bbox="211 1559 760 1646">Remove the 3 foot nuts fixing compressor and then lift the compressor upwards to remove the compressor and damping cushion. Note: Keep the ports of discharge pipe and suction pipe from foreign objects.</p>  <p data-bbox="1354 1677 1484 1705">compressor</p>

Appendix:

Appendix 1: Reference Sheet of Celsius and Fahrenheit

Conversion formula for Fahrenheit degree and Celsius degree: $T_f = T_c \times 1.8 + 32$

Set temperature

Fahrenheit display temperature (°F)	Fahrenheit (°F)	Celsius (°C)	Fahrenheit display temperature (°F)	Fahrenheit (°F)	Celsius (°C)	Fahrenheit display temperature (°F)	Fahrenheit (°F)	Celsius (°C)
61	60.8	16	69/70	69.8	21	78/79	78.8	26
62/63	62.6	17	71/72	71.6	22	80/81	80.6	27
64/65	64.4	18	73/74	73.4	23	82/83	82.4	28
66/67	66.2	19	75/76	75.2	24	84/85	84.2	29
68	68	20	77	77	25	86	86	30

Ambient temperature

Fahrenheit display temperature (°F)	Fahrenheit (°F)	Celsius (°C)	Fahrenheit display temperature (°F)	Fahrenheit (°F)	Celsius (°C)	Fahrenheit display temperature (°F)	Fahrenheit (°F)	Celsius (°C)
32/33	32	0	55/56	55.4	13	79/80	78.8	26
34/35	33.8	1	57/58	57.2	14	81	80.6	27
36	35.6	2	59/60	59	15	82/83	82.4	28
37/38	37.4	3	61/62	60.8	16	84/85	84.2	29
39/40	39.2	4	63	62.6	17	86/87	86	30
41/42	41	5	64/65	64.4	18	88/89	87.8	31
43/44	42.8	6	66/67	66.2	19	90	89.6	32
45	44.6	7	68/69	68	20	91/92	91.4	33
46/47	46.4	8	70/71	69.8	21	93/94	93.2	34
48/49	48.2	9	72	71.6	22	95/96	95	35
50/51	50	10	73/74	73.4	23	97/98	96.8	36
52/53	51.8	11	75/76	75.2	24	99	98.6	37
54	53.6	12	77/78	77	25			

Appendix 2: Configuration of Connection Pipe

1. Standard length of connection pipe (More details please refer to the specifications.)
2. Min. length of connection pipe is 3m.
3. Max. length of connection pipe and max. high difference. (More details please refer to the specifications.)
4. The additional refrigerant oil and refrigerant charging required after prolonging connection pipe
 - After the length of connection pipe is prolonged for 10m at the basis of standard length, you should add 5ml of refrigerant oil for each additional 5m of connection pipe.
 - The calculation method of additional refrigerant charging amount (on the basis of liquid pipe):
 - Basing on the length of standard pipe, add refrigerant according to the requirement as shown in the table. The additional refrigerant charging amount per meter is different according to the diameter of liquid pipe. See the following sheet.
 - Additional refrigerant charging amount = prolonged length of liquid pipe X additional refrigerant charging amount per meter

Additional refrigerant charging amount for R22, R407C, R410A and R134a			
Diameter of connection pipe		Outdoor unit throttle	
Liquid pipe	Gas pipe	Cooling only(g/m)	Cooling and heating(g/m)
1/4"	3/8" or 1/2"	15	20
1/4" or 3/8"	5/8" or 3/4"	15	50
1/2"	3/4" or 7/8"	30	120
5/8"	1" or 1 1/4"	60	120
3/4"	/	250	250
7/8"	/	350	350

Appendix 3: Pipe Expanding Method

⚠ Note:

Improper pipe expanding is the main cause of refrigerant leakage. Please expand the pipe according to the following steps:

A: Cut the pip

- Confirm the pipe length according to the distance of indoor unit and outdoor unit.
- Cut the required pipe with pipe cutter.

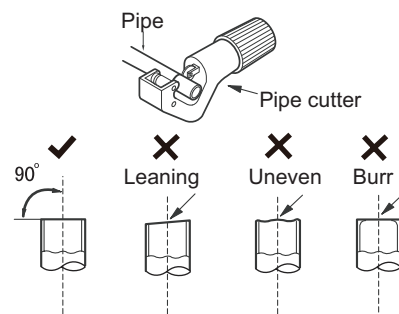

B: Remove the burrs

- Remove the burrs with shaper and prevent the burrs from getting into the pipe.

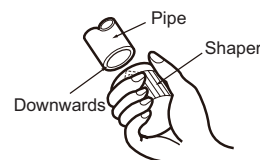

C: Put on suitable insulating pipe

D: Put on the union nut

- Remove the union nut on the indoor connection pipe and outdoor valve; install the union nut on the pipe.

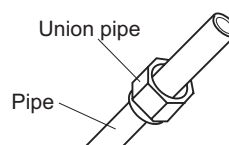

E: Expand the port

- Expand the port with expander.

⚠ Note:

- "A" is different according to the diameter, please refer to the sheet below:

Outer diameter(mm)	A(mm)	
	Max	Min
Φ6 - 6.35 (1/4")	1.3	0.7
Φ9 - Φ9.52 (3/8")	1.6	1.0
Φ12 - 12.70 (1/2")	1.8	1.0
Φ16 - 15.88 (5/8")	2.4	2.2

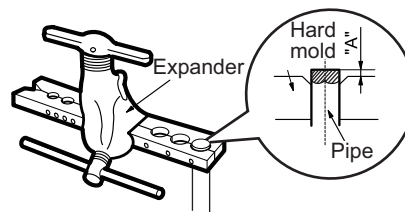

F: Inspection

- Check the quality of expanding port. If there is any blemish, expand the port again according to the steps above.

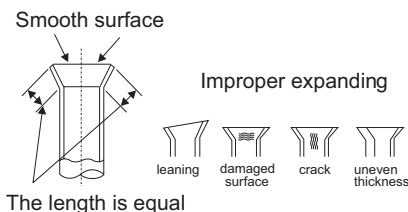

Appendix 4: List of Resistance for Temperature Sensor

Resistance Table of Ambient Temperature Sensor for Indoor and Outdoor Units(15K)

Temp(°C)	Resistance(kΩ)	Temp(°C)	Resistance(kΩ)	Temp(°C)	Resistance(kΩ)	Temp(°C)	Resistance(kΩ)
-19	138.1	20	18.75	59	3.848	98	1.071
-18	128.6	21	17.93	60	3.711	99	1.039
-17	121.6	22	17.14	61	3.579	100	1.009
-16	115	23	16.39	62	3.454	101	0.98
-15	108.7	24	15.68	63	3.333	102	0.952
-14	102.9	25	15	64	3.217	103	0.925
-13	97.4	26	14.36	65	3.105	104	0.898
-12	92.22	27	13.74	66	2.998	105	0.873
-11	87.35	28	13.16	67	2.896	106	0.848
-10	82.75	29	12.6	68	2.797	107	0.825
-9	78.43	30	12.07	69	2.702	108	0.802
-8	74.35	31	11.57	70	2.611	109	0.779
-7	70.5	32	11.09	71	2.523	110	0.758
-6	66.88	33	10.63	72	2.439	111	0.737
-5	63.46	34	10.2	73	2.358	112	0.717
-4	60.23	35	9.779	74	2.28	113	0.697
-3	57.18	36	9.382	75	2.206	114	0.678
-2	54.31	37	9.003	76	2.133	115	0.66
-1	51.59	38	8.642	77	2.064	116	0.642
0	49.02	39	8.297	78	1.997	117	0.625
1	46.6	40	7.967	79	1.933	118	0.608
2	44.31	41	7.653	80	1.871	119	0.592
3	42.14	42	7.352	81	1.811	120	0.577
4	40.09	43	7.065	82	1.754	121	0.561
5	38.15	44	6.791	83	1.699	122	0.547
6	36.32	45	6.529	84	1.645	123	0.532
7	34.58	46	6.278	85	1.594	124	0.519
8	32.94	47	6.038	86	1.544	125	0.505
9	31.38	48	5.809	87	1.497	126	0.492
10	29.9	49	5.589	88	1.451	127	0.48
11	28.51	50	5.379	89	1.408	128	0.467
12	27.18	51	5.197	90	1.363	129	0.456
13	25.92	52	4.986	91	1.322	130	0.444
14	24.73	53	4.802	92	1.282	131	0.433
15	23.6	54	4.625	93	1.244	132	0.422
16	22.53	55	4.456	94	1.207	133	0.412
17	21.51	56	4.294	95	1.171	134	0.401
18	20.54	57	4.139	96	1.136	135	0.391
19	19.63	58	3.99	97	1.103	136	0.382

Resistance Table of Tube Temperature Sensors for Outdoor and Indoor(20K)

Temp(°C)	Resistance(kΩ)	Temp(°C)	Resistance(kΩ)	Temp(°C)	Resistance(kΩ)	Temp(°C)	Resistance(kΩ)
-19	181.4	20	25.01	59	5.13	98	1.427
-18	171.4	21	23.9	60	4.948	99	1.386
-17	162.1	22	22.85	61	4.773	100	1.346
-16	153.3	23	21.85	62	4.605	101	1.307
-15	145	24	20.9	63	4.443	102	1.269
-14	137.2	25	20	64	4.289	103	1.233
-13	129.9	26	19.14	65	4.14	104	1.198
-12	123	27	18.13	66	3.998	105	1.164
-11	116.5	28	17.55	67	3.861	106	1.131
-10	110.3	29	16.8	68	3.729	107	1.099
-9	104.6	30	16.1	69	3.603	108	1.069
-8	99.13	31	15.43	70	3.481	109	1.039
-7	94	32	14.79	71	3.364	110	1.01
-6	89.17	33	14.18	72	3.252	111	0.983
-5	84.61	34	13.59	73	3.144	112	0.956
-4	80.31	35	13.04	74	3.04	113	0.93
-3	76.24	36	12.51	75	2.94	114	0.904
-2	72.41	37	12	76	2.844	115	0.88
-1	68.79	38	11.52	77	2.752	116	0.856
0	65.37	39	11.06	78	2.663	117	0.833
1	62.13	40	10.62	79	2.577	118	0.811
2	59.08	41	10.2	80	2.495	119	0.77
3	56.19	42	9.803	81	2.415	120	0.769
4	53.46	43	9.42	82	2.339	121	0.746
5	50.87	44	9.054	83	2.265	122	0.729
6	48.42	45	8.705	84	2.194	123	0.71
7	46.11	46	8.37	85	2.125	124	0.692
8	43.92	47	8.051	86	2.059	125	0.674
9	41.84	48	7.745	87	1.996	126	0.658
10	39.87	49	7.453	88	1.934	127	0.64
11	38.01	50	7.173	89	1.875	128	0.623
12	36.24	51	6.905	90	1.818	129	0.607
13	34.57	52	6.648	91	1.736	130	0.592
14	32.98	53	6.403	92	1.71	131	0.577
15	31.47	54	6.167	93	1.658	132	0.563
16	30.04	55	5.942	94	1.609	133	0.549
17	28.68	56	5.726	95	1.561	134	0.535
18	27.39	57	5.519	96	1.515	135	0.521
19	26.17	58	5.32	97	1.47	136	0.509

Resistance Table of Discharge Temperature Sensor for Outdoor(50K)

Temp(°C)	Resistance(kΩ)	Temp(°C)	Resistance(kΩ)	Temp(°C)	Resistance(kΩ)	Temp(°C)	Resistance(kΩ)
-29	853.5	10	98	49	18.34	88	4.75
-28	799.8	11	93.42	50	17.65	89	4.61
-27	750	12	89.07	51	16.99	90	4.47
-26	703.8	13	84.95	52	16.36	91	4.33
-25	660.8	14	81.05	53	15.75	92	4.20
-24	620.8	15	77.35	54	15.17	93	4.08
-23	580.6	16	73.83	55	14.62	94	3.96
-22	548.9	17	70.5	56	14.09	95	3.84
-21	516.6	18	67.34	57	13.58	96	3.73
-20	486.5	19	64.33	58	13.09	97	3.62
-19	458.3	20	61.48	59	12.62	98	3.51
-18	432	21	58.77	60	12.17	99	3.41
-17	407.4	22	56.19	61	11.74	100	3.32
-16	384.5	23	53.74	62	11.32	101	3.22
-15	362.9	24	51.41	63	10.93	102	3.13
-14	342.8	25	49.19	64	10.54	103	3.04
-13	323.9	26	47.08	65	10.18	104	2.96
-12	306.2	27	45.07	66	9.83	105	2.87
-11	289.6	28	43.16	67	9.49	106	2.79
-10	274	29	41.34	68	9.17	107	2.72
-9	259.3	30	39.61	69	8.85	108	2.64
-8	245.6	31	37.96	70	8.56	109	2.57
-7	232.6	32	36.38	71	8.27	110	2.50
-6	220.5	33	34.88	72	7.99	111	2.43
-5	209	34	33.45	73	7.73	112	2.37
-4	198.3	35	32.09	74	7.47	113	2.30
-3	199.1	36	30.79	75	7.22	114	2.24
-2	178.5	37	29.54	76	7.00	115	2.18
-1	169.5	38	28.36	77	6.76	116	2.12
0	161	39	27.23	78	6.54	117	2.07
1	153	40	26.15	79	6.33	118	2.02
2	145.4	41	25.11	80	6.13	119	1.96
3	138.3	42	24.13	81	5.93	120	1.91
4	131.5	43	23.19	82	5.75	121	1.86
5	125.1	44	22.29	83	5.57	122	1.82
6	119.1	45	21.43	84	5.39	123	1.77
7	113.4	46	20.6	85	5.22	124	1.73
8	108	47	19.81	86	5.06	125	1.68
9	102.8	48	19.06	87	4.90	126	1.64

NOTE CONCERNING PROTECTION OF ENVIRONMENT

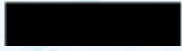

This product must not be disposed of via normal household waste after its service life, but must be taken to a collection station for the recycling of electrical and electronic devices. The symbol on the product, the operating instructions or the packaging indicate such disposal procedures. The materials are recyclable in accordance with their respective symbols. By means of re-use, material recycling or any other form of recycling old appliances you are making an important contribution to the protection of our environment. Please ask your local council where your nearest disposal station is located.

INFORMATION CONCERNING USED REFRIGERANT MEDIUM

This unit is containing fluorinated gases included in the Kyoto protocol.
The maintenance and the liquidation must be carried out by qualified personnel.

Type of refrigerant: R32

The quantity of the refrigerant: Please see the unit label.

The value GWP: 675 (1 kg R32 = 0,675 t CO₂ eq)

GWP = Global Warming Potential



Appliance filled with flammable gas R32.

In case of quality problem or other please contact your local supplier or authorized service center.

Emergency number: 112

PRODUCER

SINCLAIR CORPORATION Ltd.

1-4 Argyll St.

London W1F 7LD

Great Britain

www.sinclair-world.com

This product was manufactured in China (Made in China).

REPRESENTATIVE

SINCLAIR Global Group s.r.o.

Purkynova 45

612 00 Brno

Czech Republic

TECHNICAL SUPPORT

SINCLAIR Global Group s.r.o.

Purkynova 45

612 00 Brno

Czech Republic

Tel.: +420 800 100 285 | Fax: +420 541 590 124

www.sinclair-solutions.com | info@sinclair-solutions.com



