

# **FULL DC INVERTER SYSTEMS ENGINEERING DATA BOOK**

SAHK-xx

SINCLAIR AIR HANDLING KIT

Original instructions

**IMPORTANT NOTE:**

Read this manual carefully before installing or operating your new air conditioning unit. Make sure to save this manual for future reference.

# CONTENTS

<b>1 Introduction .....</b>	<b>2</b>
<b>2 System Layout .....</b>	<b>3</b>
<b>3 VRF-AHU System Schematic .....</b>	<b>4</b>
<b>4 Nomenclature .....</b>	<b>5</b>
<b>5 Typical Applications.....</b>	<b>5</b>
<b>6 Specifications .....</b>	<b>7</b>
<b>7 Selection of AHU when multiple Kits in parallel.....</b>	<b>8</b>
<b>8 Dimensions .....</b>	<b>9</b>
<b>9 Piping Diagrams .....</b>	<b>10</b>
<b>10 General Notes .....</b>	<b>11</b>
<b>11 Installation of AHU Kit.....</b>	<b>12</b>
<b>12 Selection of Controllers .....</b>	<b>42</b>
<b>13 Dip Switch definitions.....</b>	<b>49</b>
<b>14 Error Code and Spot Check .....</b>	<b>54</b>
<b>15 Accessories.....</b>	<b>56</b>
<b>16 Appendix.....</b>	<b>57</b>



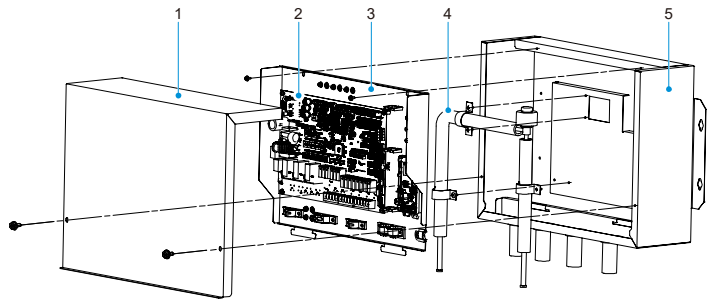
# 1 Introduction

The AHU Kit can be connected to the heat pump/heat recovery/cooling only ODU and the third party AHU. Every third party AHU can be connected to one AHU Kit or to several AHU Kites in a parallel connection (up to four). This manual describes how to install and operate an AHU Kit.

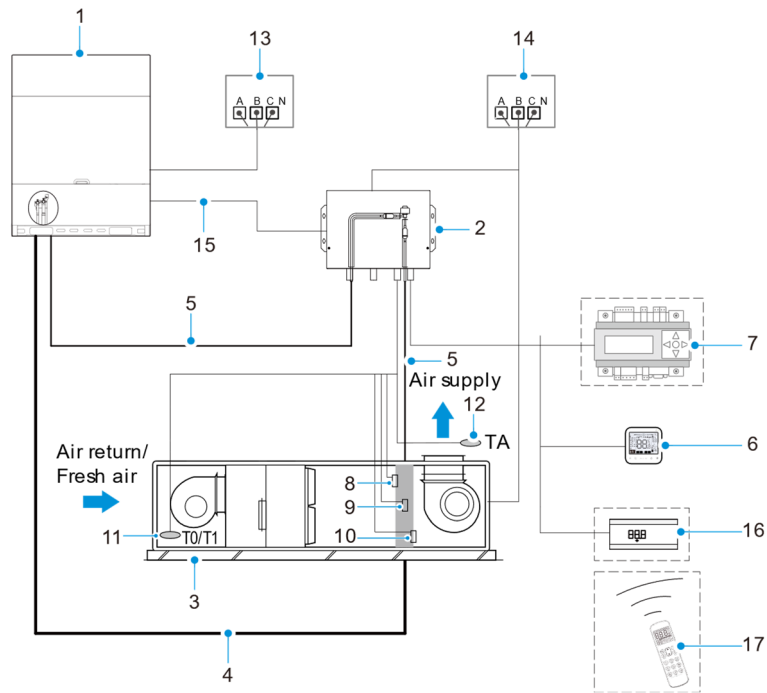
Using an AHU Kit, a unit can be controlled by either return air temperature or by outlet air temperature.

- When return air temperature control is selected, the connected AHU can be considered to be a standard IDU.
- Users can opt to use the factory controller or a third party controller.
- The AHU Kit has an input port of 0-10V. A third party controller is required to provide 0-10V of input. The system capacity requirement or temperature can be set based on 0-10V input.
- **Appearance of the AHU Kit:**

No	Parts
1	Box cover
2	Main control board
3	Main control board support seat
4	Electronic expansion valve assembly
5	Box body



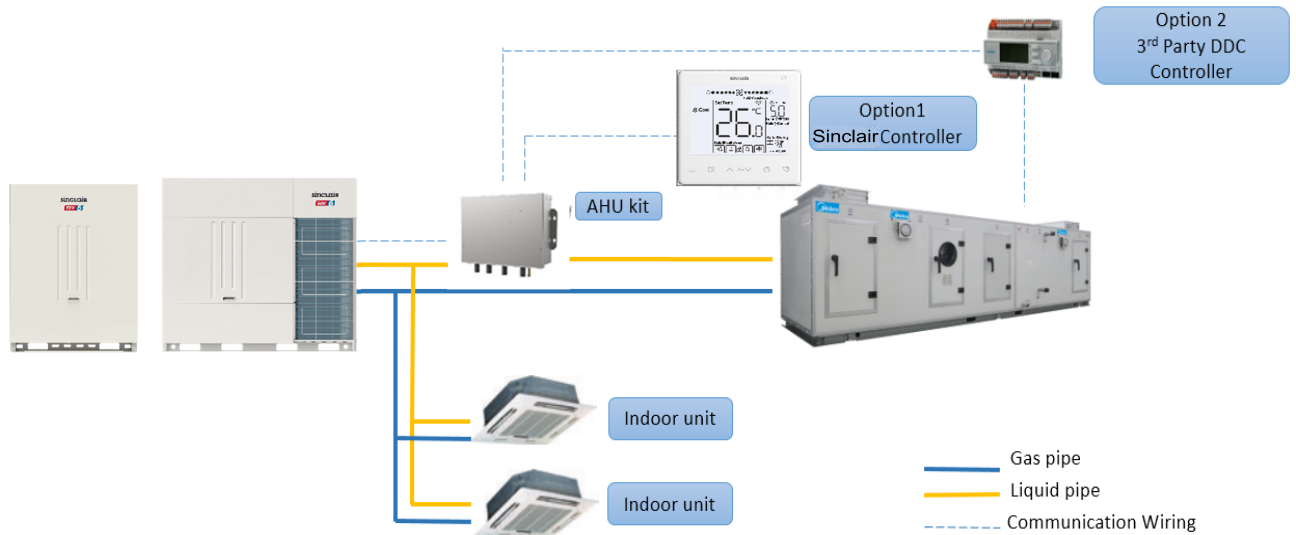
## 2 System Layout



No.	Name	Description
1	ODU	Supports heat pump type and heat recovery type VRF ODUs
2	Kit	Reserve brazing joint for the refrigerant inlet/outlet pipe
3	Third-party AHU	Only air-cooled direct expansion AHU is supported
4	Connecting piping between ODU and AHU	For piping diameters, see Pipe Layout in the related ODU Installation Manual
5	Connecting piping between ODU and the kit, connecting piping between AHU and the kit	Installation Manual
6	Wired controller	Factory default
7	Third-party controller	DDC controller
8	T2A-AHU heat exchanger liquid pipe temperature sensor	Factory default
9	T2-AHU heat exchanger middle temperature sensor	Factory default
10	T2B-AHU heat exchanger gas pipe temperature sensor	Factory default
11	T1-AHU indoor return air temperature sensor	Factory default
11	T0-AHU outdoor fresh air temperature sensor	Factory default
12	TA-AHU outlet air temperature sensor	Factory default
13	ODU power supply	For power supply specifications, see Power Supply Selection
14	AHU and kit power supply	The power supply is separated from the outdoor unit connection
15	Communication wires between the kit and ODU	For the materials and specifications of communication wires, see Electrical Installation-Connection of Signal Cables in Installation Manual
16	Display box	Optional, can be purchased separately from the factory
17	Remote controller	Optional, can be purchased separately from the factory

### 3 VRF-AHU System Schematic

Figure 3-1.1: System schematic



4

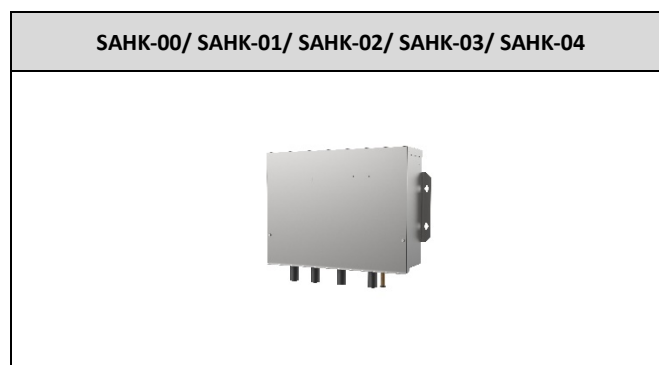
The system is composed by largely indoor and outdoor parts. Outdoor part is Sinclair VRF outdoor unit. Indoor part includes other brand direct expansion type AHU (Local supply) and Sinclair AHU Kit. AHU Kit forms the connection between Sinclair VRF outdoor unit and other brand direct expansion type AHU.

1. Outdoor: Sinclair VRF outdoor unit  
SDV5, SDV5, SDV5-3P
2. Indoor: Direct expansion type AHU (Local supply)  
Direct Expansion type AHU supplied by local market

3. VRF AHU Kit  
PCBs, EXV, EXV Coil, Temperature sensors (T0 fresh inlet air temperature sensor, T1 return air temperature sensor, TA outlet air temperature sensor, T2A heat exchanger liquid pipe temperature sensor, T2 heat exchanger middle temperature sensor, T2B heat exchanger gas pipe temperature sensor), Wired controller and Display board.

- 4.DDC (Direct Digital Control) controller  
DDC controller is optional. It's supplied by the third party such as SIEMENS. Through DDC, some functions such as temperature setting control and capacity setting control can be realized.

#### Product Lineup



## 4 Nomenclature

SAHK - 01

### Connected-AHU's Capacity Index

00: 1.8-9kW

01: 9-20kW

02: 20-36kW

03: 36-56kW

04: 56-168kW

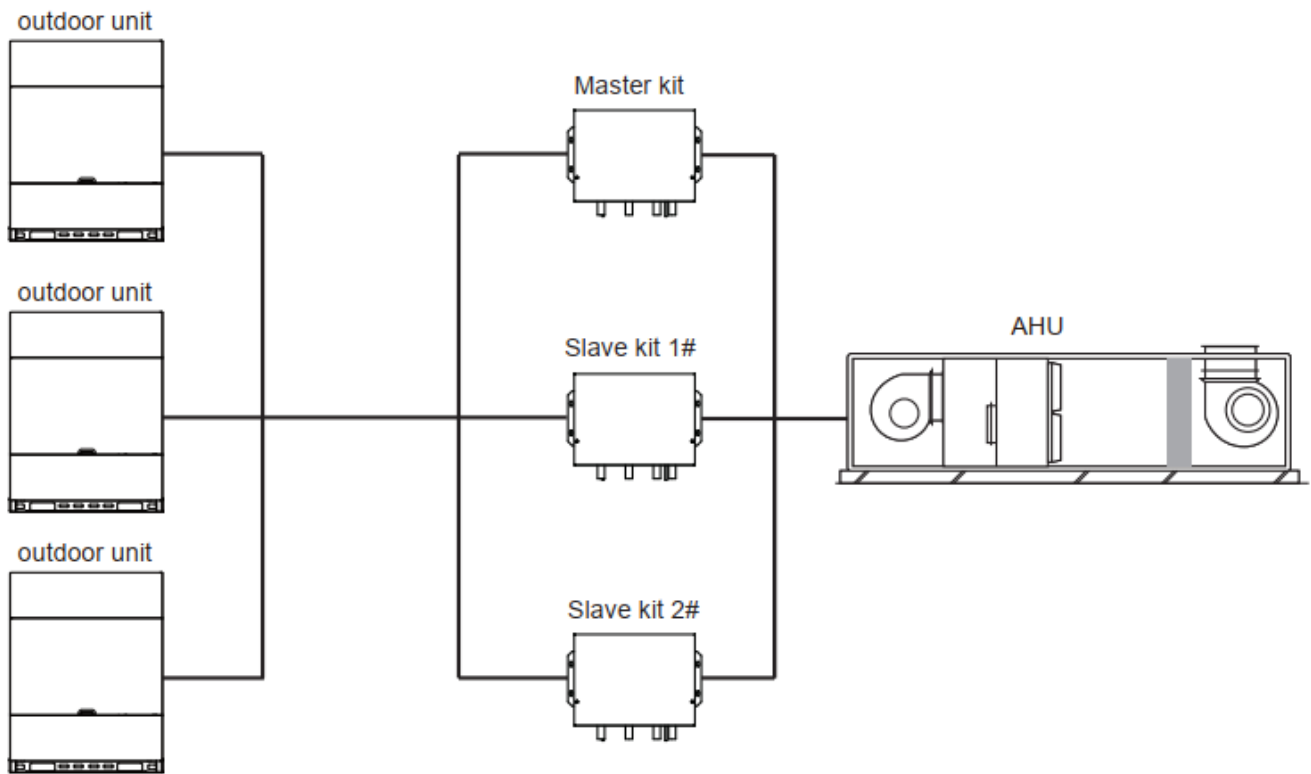
### Sinclair Air Handling Kit

## 5 Typical Applications

### 5.1 Single VRF AHU Kit connects to one AHU

Multiple kits are connected in parallel, and the refrigerant is connected to the AHU heat exchanger after converging through the branch joint. A maximum of four kits can be connected in parallel. The system connection is shown in the figure below:

Figure 5-1.1: Single VRF AHU Kit connect to one AHU

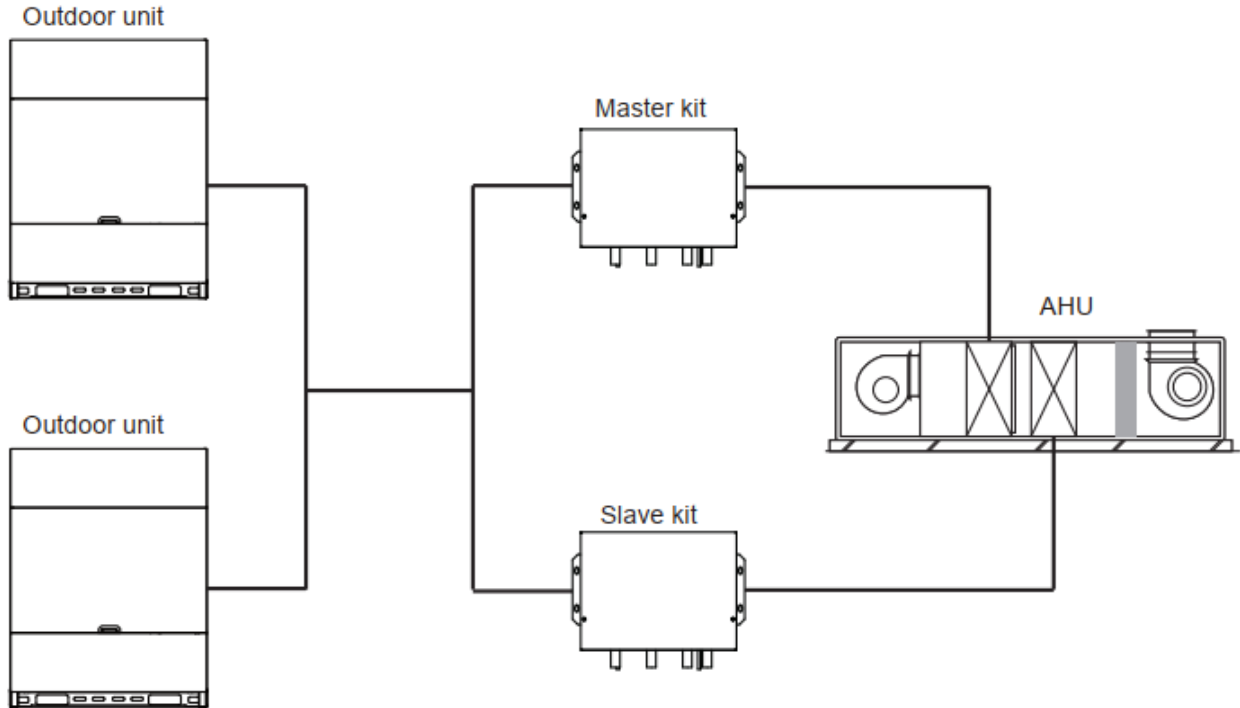


**Notes:** The example is just for application illustration. Only the liquid pipe connection is shown.

## 5.2 Multiple VRF AHU Kites connect with one AHU

Multiple kits are connected in parallel, and each kit corresponds to a heat exchanger of the AHU. A maximum of four kits can be connected in parallel. The system connection is shown in the figure below:

Figure 5-1.2: Multiple VRF AHU Kites connect to one AHU

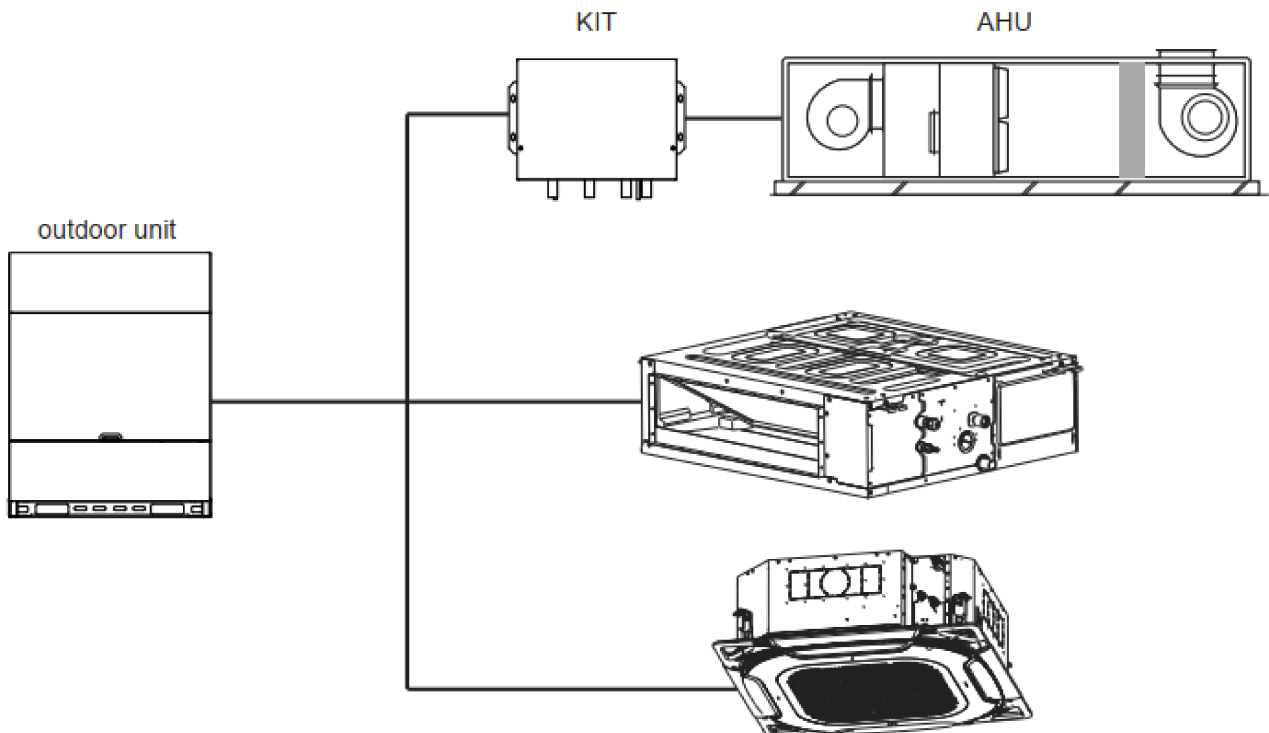


Notes: The example is just for application illustration. Only the liquid pipe connection is shown

## 5.3 AHU and VRF IDU Combination

DX type AHU and VRF indoor units can be combined in the same refrigerant system.

Figure 5-1.3: AHU and VRF IDU combination application



Notes: The example is just for application illustration. Only the liquid pipe connection is shown

## 6 Specifications

### SAHK-00 / SAHK-01 / SAHK-02 / SAHK-03 / SAHK-04

Table 6-1.1: SAHK-00(01,02,03,04) specifications

Model		SAHK-00	SAHK-01	SAHK-02	SAHK-03	SAHK-04
Power supply		220-240V~ 50/60Hz				
Connected indoor unit capacity	kW	1.8-9	9~20	20~36	36~56	56~168
IP-class		IPX4	IPX4	IPX4	IPX4	IPX4
Piping size (In/Out)	mm	Φ8/Φ8	Φ8/Φ8	Φ12.7/Φ12.7	Φ12.7/Φ12.7	Φ12.7/Φ12.7
Weight (Net/Gross)	kg	6.2/8.8	6.2/8.8	6.4/9.0	6.4/9.0	6.6/9.2
Dimension		479×384×134				
Packing dimension		565×470×220				

## 7 Selection of AHU when multiple Kits in parallel

When connecting Kits in parallel, comply with the following requirements: The maximum capacity model and the minimum capacity model in the parallel combination must be adjacent models. For example:

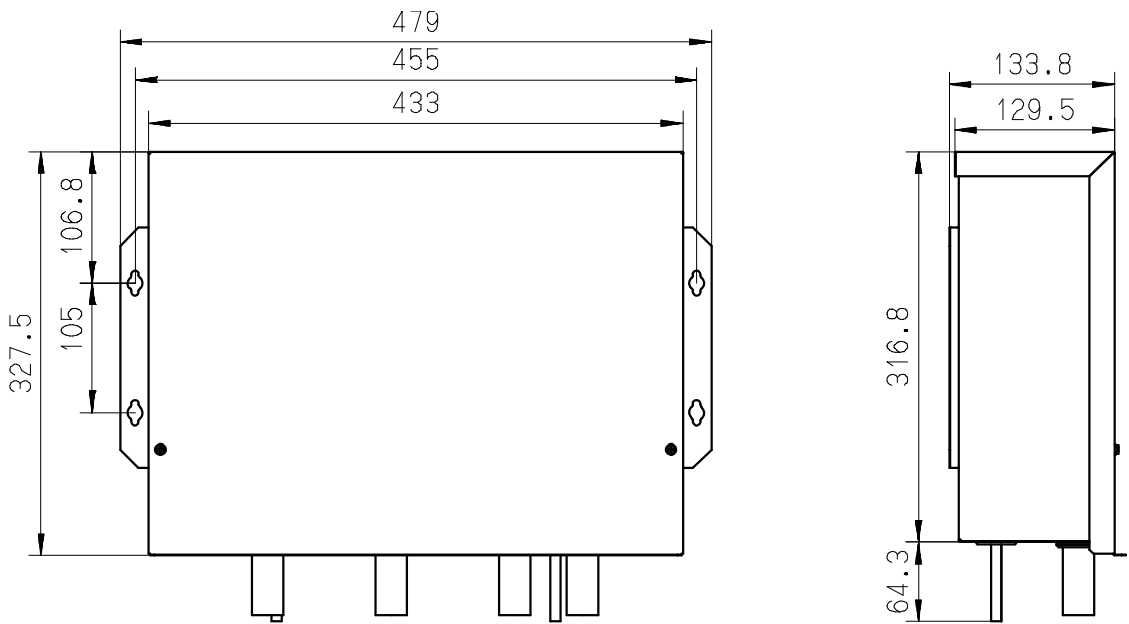
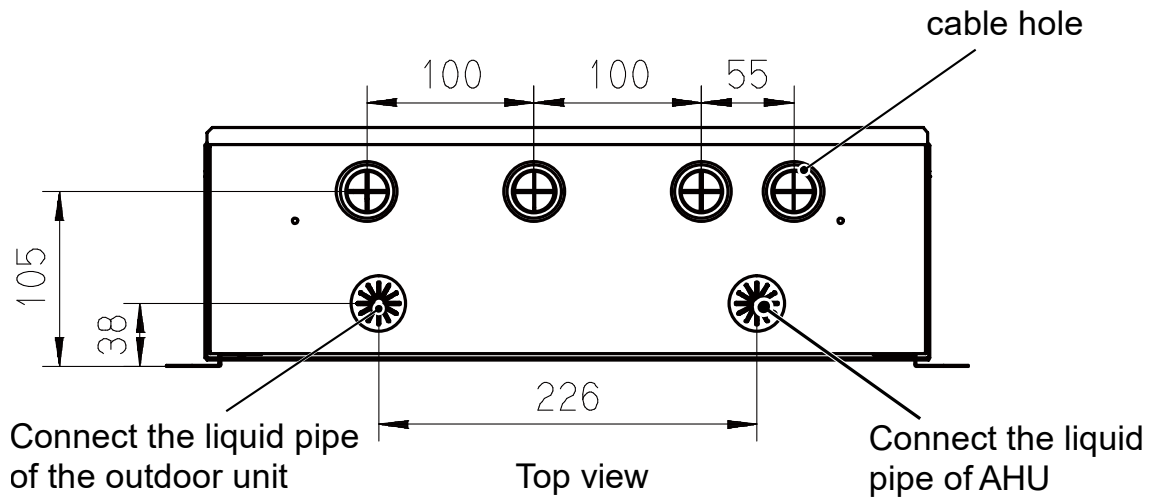
Table 6-1.1: AHU-Kit combination table

Combinations	Allow or not ( m <sup>3</sup> /h)
SAHK-04 + SAHK-03	Yes, the maximum capacity model is 04, and the minimum capacity model is 03. The two models must be adjacent to each other.
SAHK-00 + SAHK-01 + SAHK-01	Yes, the maximum capacity model is 01, and the minimum capacity model is 00. The two models must be adjacent to each other.
SAHK-04 + SAHK-02	No, the maximum capacity model is 04 and the minimum capacity model is 02. The two models do not meet the requirements for adjacent space.
SAHK-00 + SAHK-01 + SAHK-03	If no, the maximum capacity model is 03, and the minimum capacity model is 00. The two models do not meet adjacency requirements.

## 8 Dimensions

SAHK-00 / SAHK-01 / SAHK-02 / SAHK-03 / SAHK-04

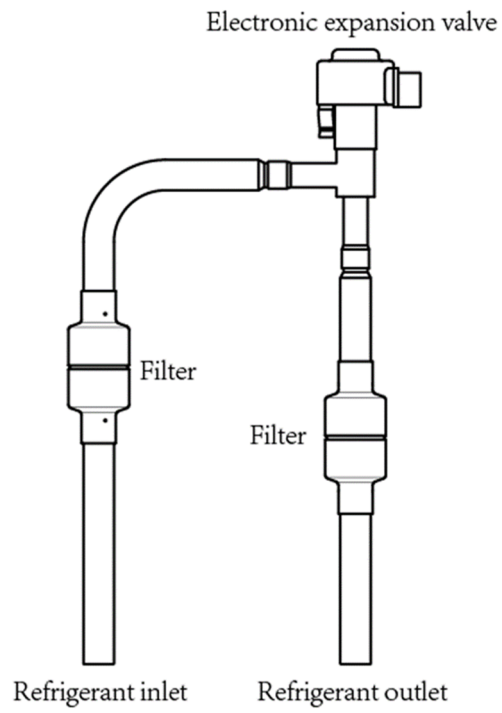
Figure 8-1.1: SAHK-00(01,02,03,04) dimensions (unit: mm)



## 9 Piping Diagrams

SAHK-00 / SAHK-01 / SAHK-02/SAHK-03/ SAHK-04

Figure 9-1.1: Piping diagrams



---

## 10 General Notes

### 10.1 Notes for Installers

The information contained in this Engineering Data Book may primarily be of use during the system design stage of a VRF-AHU project. Additional important information which may primarily be of use during field installation has been placed in boxes, such as the example below, titled “Notes for installers”.

#### Notes for installers



- Notes for installers boxes contain important information which may primarily be of use during field installation, rather than during desk-based system design.

### 10.2 Definitions

In this Engineering Data Book, the term “applicable legislation” refers to all national, local and other laws, standards, codes, rules, regulations and other legislation that apply in a given situation.

### 10.3 Precautions

All system installation including electrical works must only be carried out by competent and suitably qualified, certified and accredited professionals and in accordance with all applicable legislation.

## 11 Installation of AHU Kit

### 11.1 Pre- Installation

For ODU installation, please refer to the ODU installation manual. For AHU installation, please refer to the AHU installation manual. For charging and adding refrigerant, please refer to both manuals.

This Kit can connect to an R410A and R32 refrigerant system.

During the installation of connecting pipes, do not let air, dust, or other sundries enter the piping system.

Install the connecting pipe only after the AHU Kit and ODUs have been fixed.

When installing the connecting pipes, it must be kept dry and do not let water enter the piping system.

#### Notes for installers



- When units are delivered check whether any damage occurred during shipment. If there is damage, submit a written report to the shipping company.
- Check that the model, specifications and quantity of the units delivered are as ordered.
- Check that all accessories ordered have been included. Retain the Owner's Manual for future reference.

### 11.2 VRF AHU Kit Installation

VRF AHU Kit's installation should take account of the following considerations:

- VRF AHU Kites should be vertical installed.
- Please use ST3.9x25 screws for installation.
- VRF AHU Kites can't be installed horizontally.
- Make sure the laying direction of the refrigerant pipe and the connecting place of the connecting wire.

### 11.3 Selecting ODUs and Match restrictions

Table 7-1.1: Supported Models table

Indoor unit combination			Outdoor Unit					Connection rate <sup>[4]</sup>	
Combination	Capacity control method		SDV6 Platform	SDV5	SDV5-3P	Mini SDV5	SDV4F		
SAHK-xx series (SDV6)	Input set temperature <sup>[2]</sup>	Control 1	√	√	×	×	×	Indoor unit / Outdoor unit	50%~100%
		Control 2	√	√	√	×	×	Indoor unit/Outdoor unit	50%~100%
	Input the capacity value	Control 3 <sup>[3]</sup>	√	√	×	×	×	Indoor unit / Outdoor unit	50%~100%
SAHK-xx series (SDV6)+ Indoor unit <sup>[1]</sup>	Input set temperature <sup>[2]</sup>	Control 1	×	×	×	×	×	/	
		Control 2	√	√	√	×	×	Indoor unit / Outdoor unit	50%~100%
	Input the capacity value	Control 3 <sup>[3]</sup>	×	×	×	×	×	/	

Table 7-1.1: Supported Models table

Indoor unit combination			Outdoor Unit					Connection rate <sup>[4]</sup>
Combination	Capacity control method		SDV6 Platform	SDV5	SDV5-3P	Mini SDV5	SDV4F	
SAHK-xx series (SDV6)+ Fresh Air Processing Unit	Input set temperature <sup>[2]</sup>	Control 1	×	×	×	×	×	/
		Control 2	×	×	×	×	×	/
	Input the capacity value	Control 3 <sup>[3]</sup>	×	×	×	×	×	/
SAHK-xx series (SDV6)+ AHU kit -D series (SDV5)	Input set temperature <sup>[2]</sup>	Control 1	×	×	×	×	×	/
		Control 2	×	×	×	×	×	/
	Input the capacity value	Control 3 <sup>[3]</sup>	×	×	×	×	×	/

Control 1—Control: AHU supply air temperature

Control 2—Control: AHU return air temperature

Control 3—Control: AHU return air temperature or AHU supply air temperature or room temperature

The detailed explanation of the three control methods can be found in Chapter 10- Capacity Control of Installation and Operation Manual.

[1] Indoor unit does not include Fresh Air Processing Unit and Hydro Module.

[2] Input the setting temperature (Ts) using the Sinclair controller or input the set temperature value (Ts) using a third party controller 0-10 V.

[3] The temperature difference ( $\Delta T$ =The actual measured temperature - target temperature,) is programmed by a third-party controller to be converted to a 0-10V signal and the capacity or Te/Tc is adjusted according to the voltage value.

[4] Connection rate: The ratio between the total nominal cooling capacity of indoor units in the system and the total nominal cooling capacity of outdoor units is defined as the connection rate, and the nominal cooling capacity is measured in HP.

## 11.4 Selecting an AHU Kit that matches AHU

The following parameters and restrictions stipulated in the following table must be considered when selecting the AHU Kit. Otherwise, it may adversely affect the ODU's service life, operating range and reliability.

### Notes for installers



If the total capacity of IDUs exceeds the rated capacity of the ODU, the cooling and heating performance may be reduced when IDUs are in operation

### AHU heat exchanger cooling/heating capacity

Model	DIP Set Capacity	Cooling Capacity Design Range (kW)		Heating Capacity Design Range (kW)	
	Index (HP)	Minimum Value	Maximum Value	Minimum Value	Maximum Value
SAHK-00	0.8	1.8	2.8	2.2	3.2
	1	2.8	3.6	3.2	4
	1.2	3.6	4.5	4	5
	1.7	4.5	5.6	5	6.3
	2	5.6	7.1	6.3	8
	2.5	7.1	8	8	9
SAHK-01	3	8	9	9	10
	3.2	9	10	10	11.2
	3.6	10	11.2	11.2	12.5
	4	11.2	14	12.5	16
	5	14	16	16	18
SAHK-02	6	16	18	18	20
	6.5	18	20	20	22
	7	20	22	22	25
	8	22	25	25	30
SAHK-03	10	25	30	30	36
	12	30	36	36	40
	14	36	40	40	45
SAHK-04	16	40	45	45	50
	18	45	50	50	56
	20	50	56	56	62
	22	56	62	62	68
	24	62	68	68	73
	26	68	73	73	78
	28	73	78	78	84
	30	78	84	84	90
	32	84	90	90	95
	34	90	95	95	101
	36	95	101	101	106
	38	101	106	106	112
	40	106	112	112	118
	42	112	118	118	123
	44	118	123	123	129
	46	123	129	129	134
	48	129	134	134	140
	50	134	140	140	146
	52	140	146	146	151
	54	146	151	151	157
56	151	157	157	162	
58	157	162	162	168	
60	162	168	168	174	

**Note:** Operation in Cool mode: vapourization temperature 6 °C, AHU heat exchanger inlet air temperature 27 °C DB/19 °C WB, superheat = 3 °C.

Operation in Heat mode: condensation temperature 48 °C, AHU heat exchanger inlet air temperature 20 °C DB/15 °C WB, subcooling = 5 °C.

AHU heat exchanger copper tube internal volume

Model	DIP Set Capacity	Heat Exchanger Copper Tube Internal Volume (cm3)	
	Index (HP)	Minimum Value	Maximum Value
SAHK-00	0.8	450	670
	1	560	840
	1.2	670	1000
	1.7	950	1420
	2	1120	1670
	2.5	1400	2090
	3	1670	2510
SAHK-01	3.2	1790	2680
	3.6	2010	3010
	4	2230	3350
	5	2790	4190
	6	3350	5020
	6.5	3880	5660
SAHK-02	7	4420	6310
	8	5490	7600
	10	6070	8380
	12	6200	10050
SAHK-03	14	7750	11730
	16	7850	13400
	18	9020	15080
	20	10550	16750
SAHK-04	22	12230	19260
	24	13700	20940
	26	13940	22610
	28	16510	24780
	30	18385	25790
	32	20260	26800
	34	20575	28475
	36	20890	30150
	38	21310	31820
	40	21730	33500
	42	23330	35440
	44	24930	37390
	46	25920	38880
	48	26920	40370
	50	27920	41870
	52	28910	43360
	54	29910	44860
	56	30910	46360
58	32400	48600	
60	33900	50850	

AHU heat exchanger inlet air flow

Model	DIP Set Capacity	AHU Air flow (m <sup>3</sup> /h)			
		Return Air Temperature Control		Supply Air Temperature Control	
	Index (HP)	Minimum Value	Maximum Value	Minimum Value	Maximum Value
SAHK-00	0.8	358	493	179	269
	1	448	616	224	336
	1.2	538	739	269	403
	1.7	762	1047	381	571
	2	896	1232	448	672
	2.5	1120	1540	560	840
	3	1344	1848	672	1008
SAHK-01	3.2	1434	1971	717	1075
	3.6	1613	2218	860	1210
	4	1792	2464	896	1344
	5	2240	3080	1120	1680
	6	2688	3696	1344	2016
	6.5	2912	4004	1456	2184
SAHK-02	7	3136	4312	1568	2352
	8	3584	4928	1792	2688
	10	4480	6160	2240	3360
	12	5376	7392	2688	4032
SAHK-03	14	6272	8624	3136	4704
	16	7168	9856	3584	5376
	18	8064	11088	4032	6048
	20	8960	12320	4480	6720
SAHK-04	22	10400	14300	5200	7800
	24	11200	15400	5600	8400
	26	12160	16720	6080	9120
	28	12800	17600	6400	9600
	30	13440	18480	6800	10200
	32	14400	19800	7200	10800
	34	15300	21000	7620	11450
	36	16000	22000	8000	12000
	38	17000	23400	8520	12780
	40	17920	24640	8960	13440
	42	18900	25870	9400	14200
	44	20000	27500	10000	15000
	46	20800	28400	10400	15500
	48	21600	29600	10800	16100
	50	22400	30800	11200	16800
	52	23300	32100	11700	17500
	54	24100	33300	12100	18100
	56	24800	34100	12400	18600
58	26000	35700	13000	19500	
60	27200	37400	13600	20400	

Perform checks upon completion of installation and pay extra attention to the following items:

- Whether the temperature sensor is properly installed
- Whether AHU Kites are properly secured
- Whether electrical connections meet specifications
- Whether wires and pipes are correctly connected
- Whether AHU Kites are properly grounded
- Whether capacity DIP switches are properly set

## 11.5 Choosing an Installation Site

The following conditions must be met:

- If the AHU Kit is installed outdoors, take waterproofing measures to protect it from rainwater.
- Avoid direct sunlight as it will heat the AHU Kit and shorten its service life, hence affecting operation.
- Select a level, solid-mounting surface.
- Do not install the AHU Kit on or above the surface of the ODU.
- Reserve some space in front of the AHU Kit for future maintenance.
- Ambient temperature: -25°C to 52°C

Range for Inlet Air Temperature on AHU Coil=T1=room temperature =return air

T1 Cooling: 17°C to 43°C

T1 Heating: 5°C to 30°C

IP Protection Degree: IP20 (after proper installation)

## 11.6 Installation Method and Size

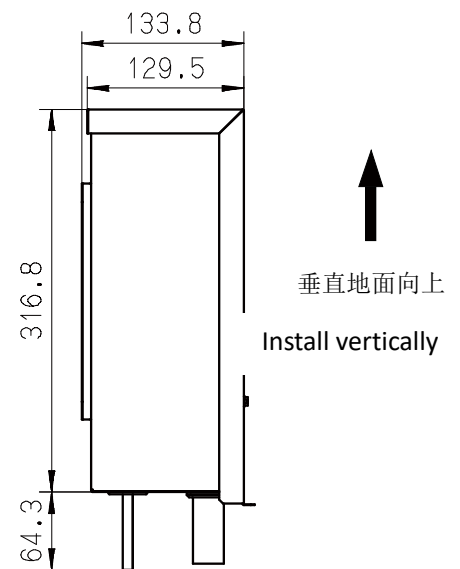
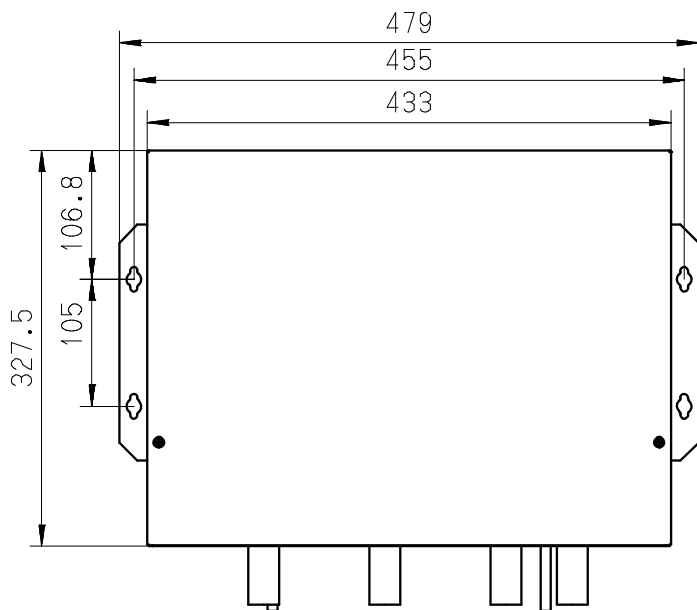
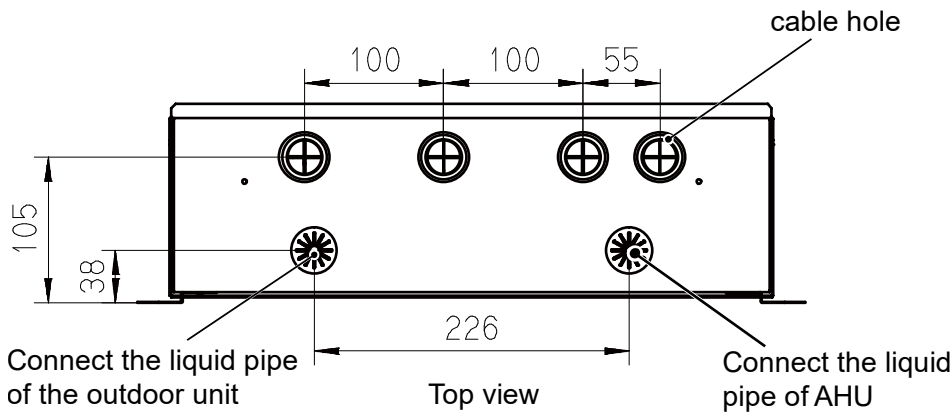
For installation of the AHU, refer to the AHU installation manual.

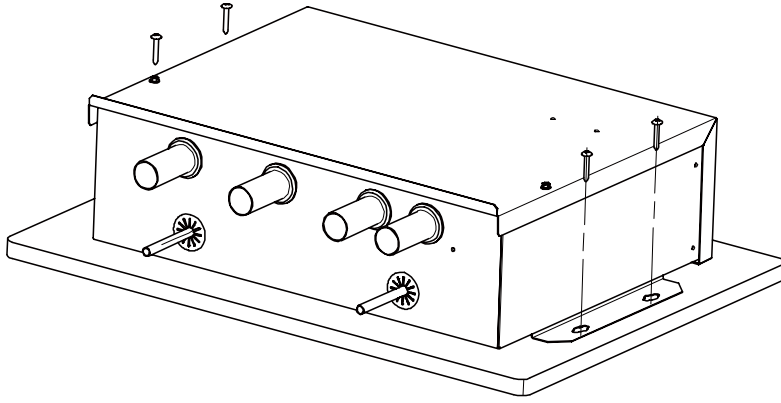
The AHU Kit can be installed in two ways:

1. When the AHU Kit's EXV remains with the AHU Kit, the AHU Kit must be installed vertically as shown in figure.

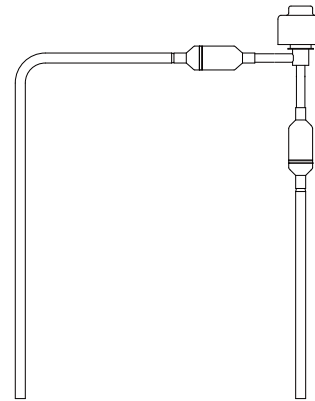
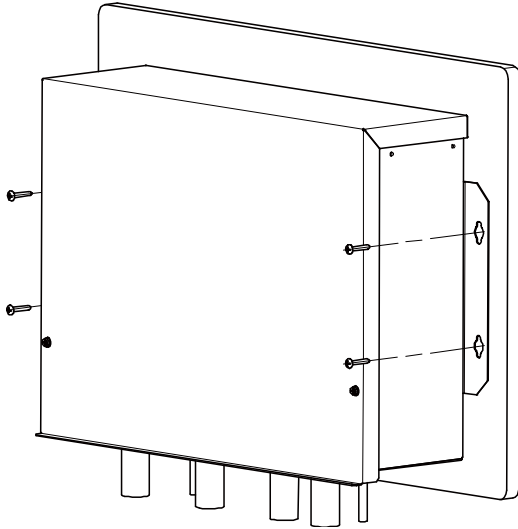
2. When the AHU Kit's EXV is split from the AHU Kit, the AHU Kit can be installed vertically or horizontally, but the split EXV must be vertical as shown in figure

Models SAHK-00~SAHK-04





↑  
Vertical ground up

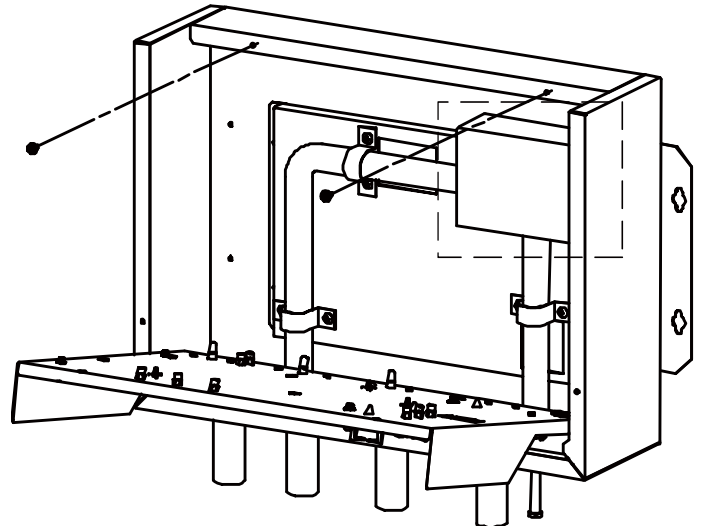
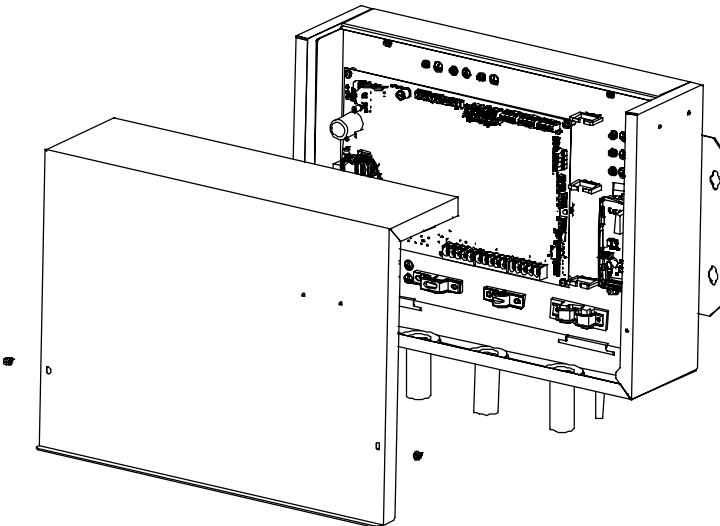


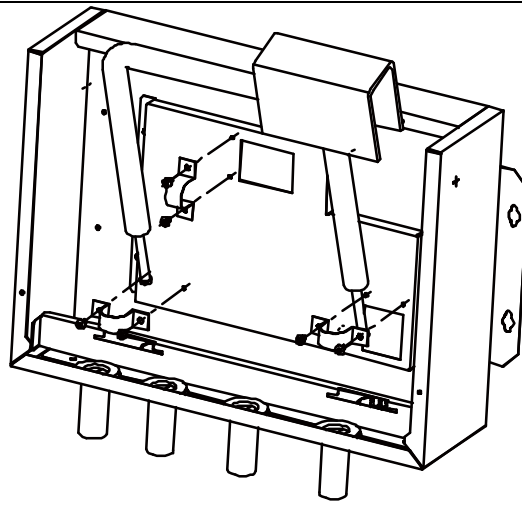
↑  
Vertical ground up

### 11.7 How to remove EXV from the AHU Kit

The EXV may be removed from the AHU Kit and positioned in an external location. Follow these steps to remove the EXV from the box.

**Models SAHK-00~SAHK-04**





## 11.8 Refrigerant Piping

### 11.8.1 Material and Size of piping

The inner and outer surfaces of copper pipes should be free of pinholes, cracks, peeling, bubbles, inclusions, copper powder, carbon deposit, green rust, dirt, serious oxide film, or obvious defects such as scratches, pits and spots.

Foreign matters (including manufacturing oil) in copper pipes must be less than or equal to 30mg/10m.

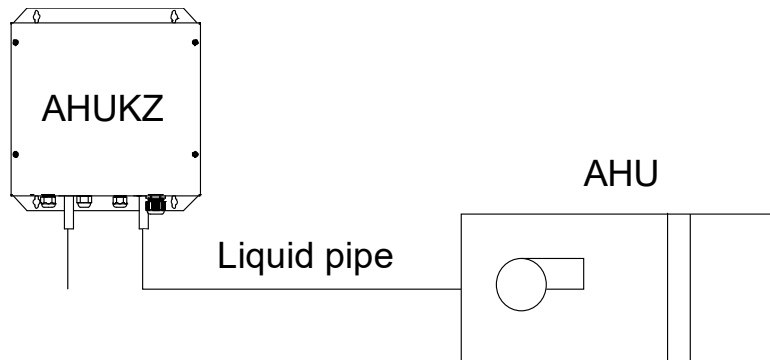
The copper piping must be made of phosphoric acid deoxidized seamless copper pipe, and the tempering grade of the pipe shall be in accordance with the following table.

Outer diameter of copper pipe (mm)	Temper classification of pipeline materials
$\leq 15.9$	O (annealed)
$\geq 19.1$	1/2H (half hard)

Note: O: coiled piping; 1/2H: straight piping.

The thickness of copper pipes must comply with the relevant laws and regulations of local countries/regions.

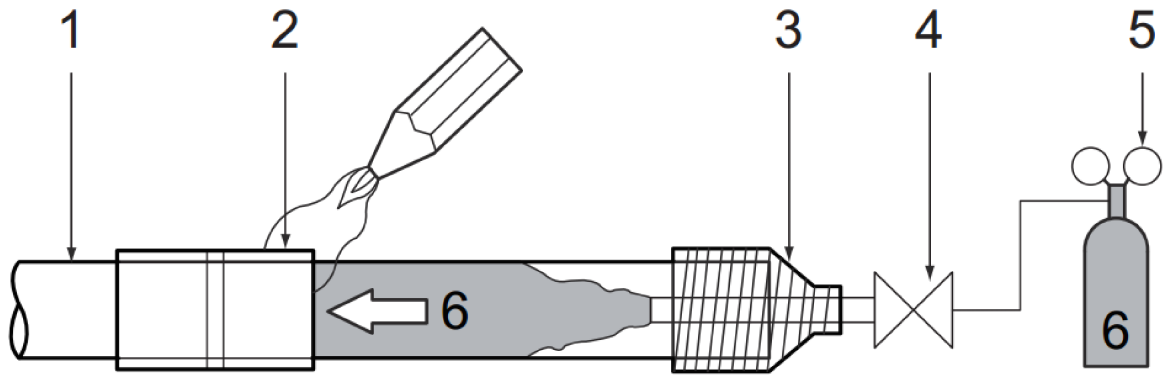
If you cannot find the copper tube with the specified outer diameter in the manual locally, the copper pipe closest to the specified outer diameter can be selected instead.



- The connecting distance of each Kit and AHU should not be more than 8 m. If the AHU Kit and EXV are to be installed apart, the distance between them must be within 5 m.
- The maximum allowed piping length between the ODU and the AHU Kit depends on the ODU model.

### 11.8.2 Welding Precautions

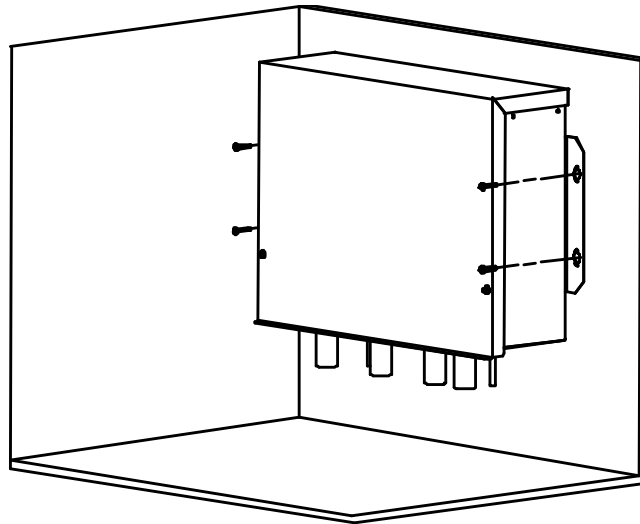
1. Nitrogen must be applied before welding. Failure to apply nitrogen in advance may result in a large amount of oxide residue on the interior surface of the copper tube, which will affect the normal operation of the valve body and compressor and may damage the compressor in serious cases.
2. When performing welding, use the pressure relief damper to keep the nitrogen pressure in the pipe at the range of 0.02-0.03 Mpa (as if the air is blowing gently on the skin).



Legend	
1	Refrigerant piping
2	Part to be brazed
3	Nitrogen connection
4	Hand- Operated valve
5	Pressure relief damper
6	Nitrogen

### 11.9 AHU Kit Installation

1. Drill four holes where you want to install the box, with the positions of the holes shown below. Secure the AHU Kit using screws.



2. Remove seals from the inlet and outlet.
3. Weld pipes on site.

#### Notes for installers

- When welding pipes at the AHU Kit, the valve body and filter should be cooled with a wet cloth to prevent damage to the EXV due to excessively high temperatures.

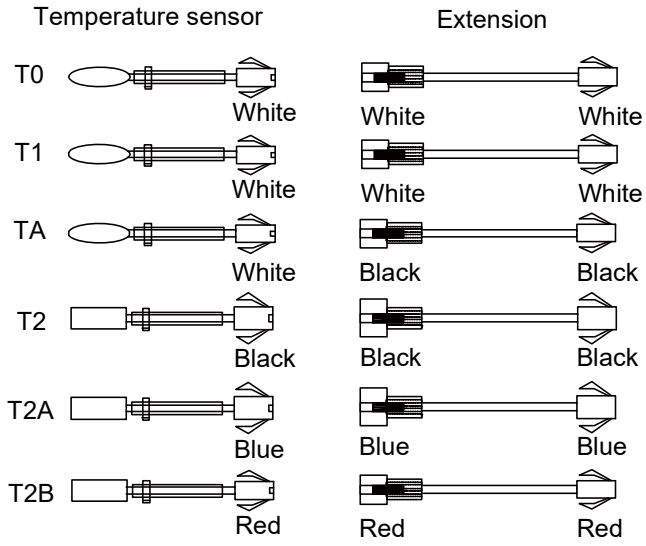
4. After the pipes are installed, insulate the pipes.
5. Pipe diameter requirements for the AHU Kit are as follows:

Kit Capacity A (×100W)	SAHK-00	SAHK-00	SAHK-01	SAHK-02	SAHK-03	SAHK-04	
	A≤56	56<A≤90	90<A≤200	200<A≤360	360<A≤560	560<A<710	710≤A≤1680
Liquid Side (mm)	φ6.35	φ9.52	φ9.52	φ12.7	φ15.9	φ15.9	φ19.1

For installation of other piping and branch pipes, refer to the ODU installation manual.

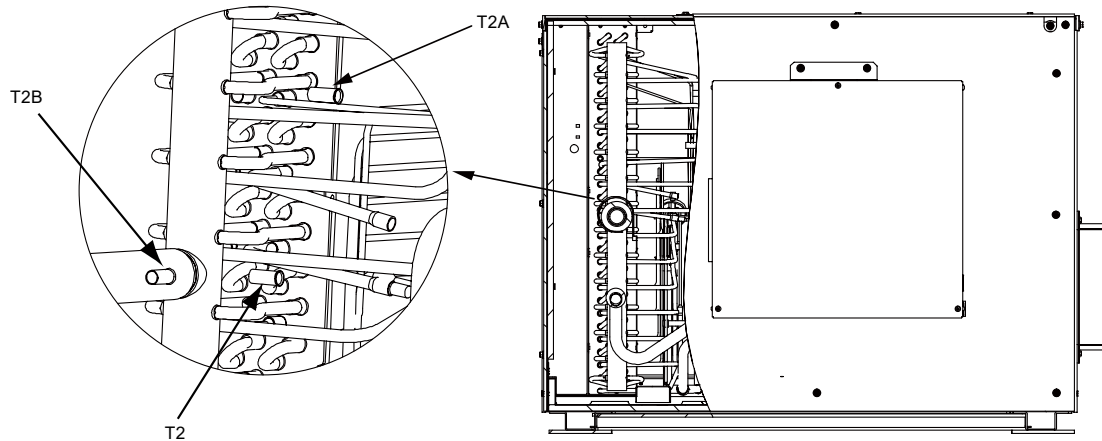
### 11.9.1 Temperature Sensor Installation

There are six temperature sensors (T0, T1, TA, T2A, T2, and T2B) and five extension wires in the accessories, as shown in Figure:



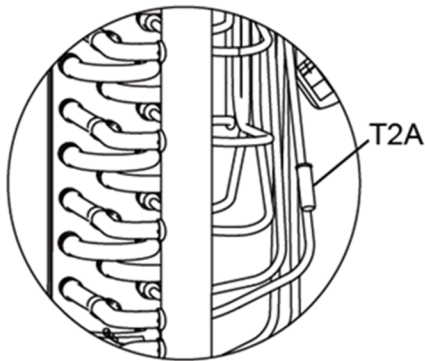
## Mounting location for temperature sensors:

Mounting location of T2A, T2, and T2B tube temperature sensors

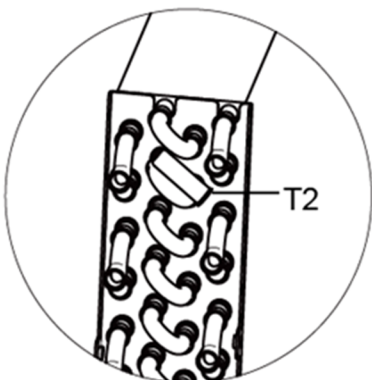


### Position requirements for heat exchanger tube temperature sensors

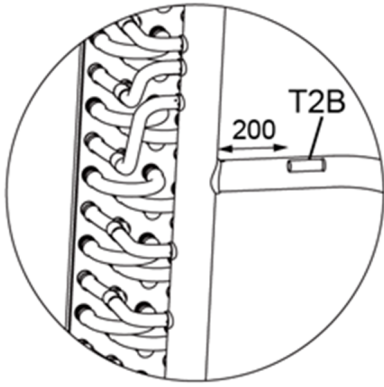
1. T2A: Install the temperature sensor on the capillary tube behind the distributor at the coldest end of the heat exchanger, noting that it should be close to the heat exchanger side, with a distance of no more than 20mm from the heat exchanger side;



2. T2: Install the temperature sensor on the semi-circular tube in the middle of the heat exchanger pipeline, taking care not to be near the distributor side, at least half the number of semi-circular tubes away from the distributor side of the flow path;

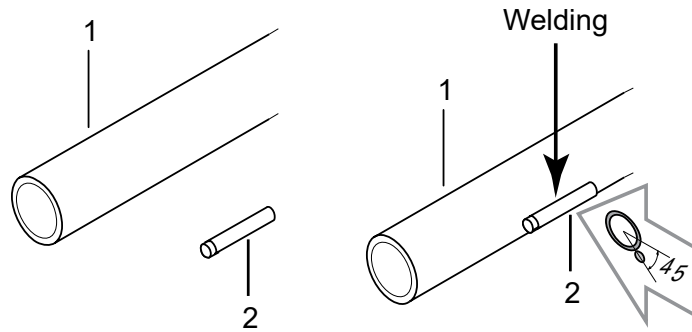


3. T2B: Install the temperature sensor on the horizontal header of the heat exchanger (about 200mm away from the vertical header), and the appropriate placement should be selected according to the pipe diameter.

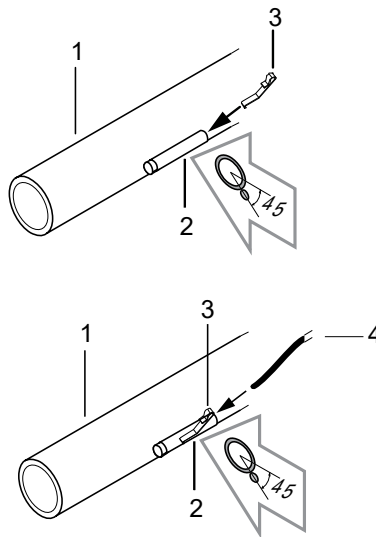


**Installation of tube temperature sensors T2A, T2 and T2B:**

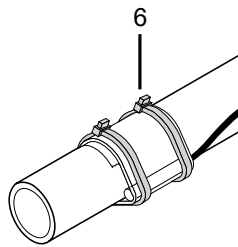
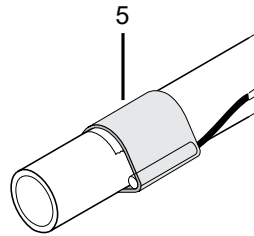
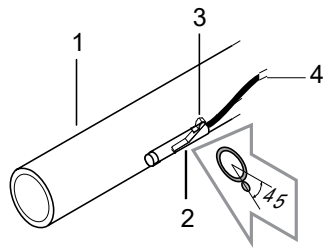
1. Weld the sleeve of the temperature sensors at the designated mounting location.



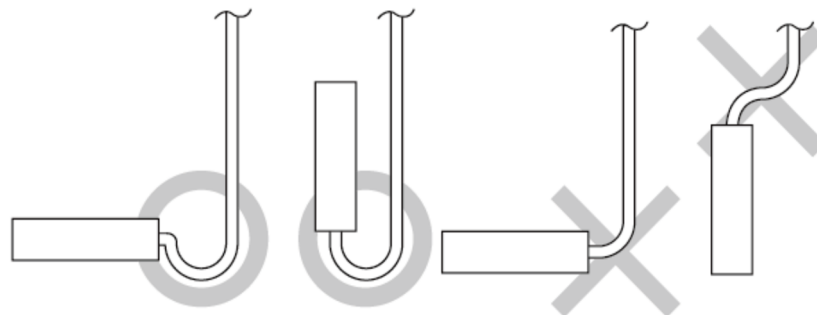
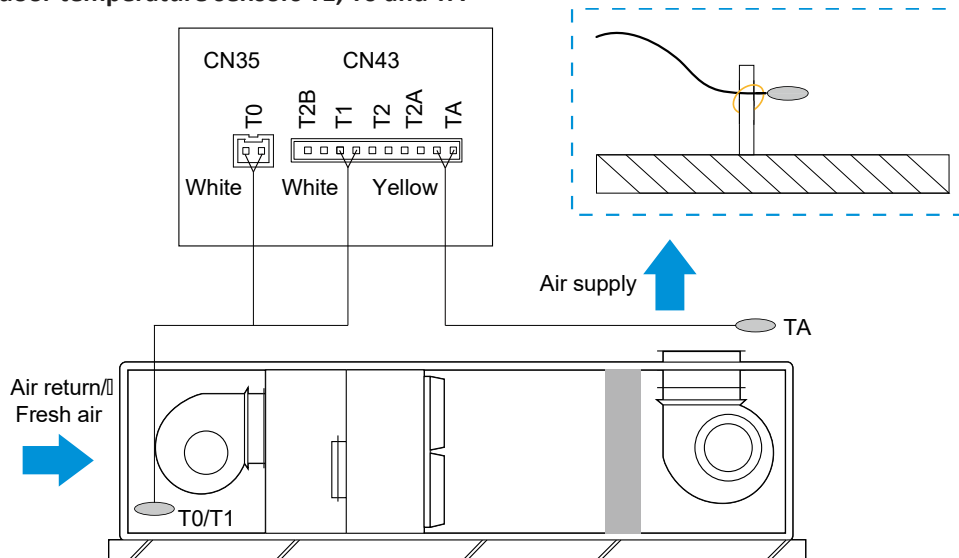
2. Insert the temperature sensor into the sleeve after inserting the buckle.



3. Apply insulation materials and secure with cable ties.



**Mounting location of indoor temperature sensors T1, T0 and TA**



Using an extension cord with the temperature sensor to allow long distance connection

The attached extension cord of the temperature sensor is 9 m long. If an extension cord is required, connect one end of the

cord to the AHU Kit and the other end to temperature sensor mounted on the AHU.

### 11.10 Electrical Connection

#### Notes for installers

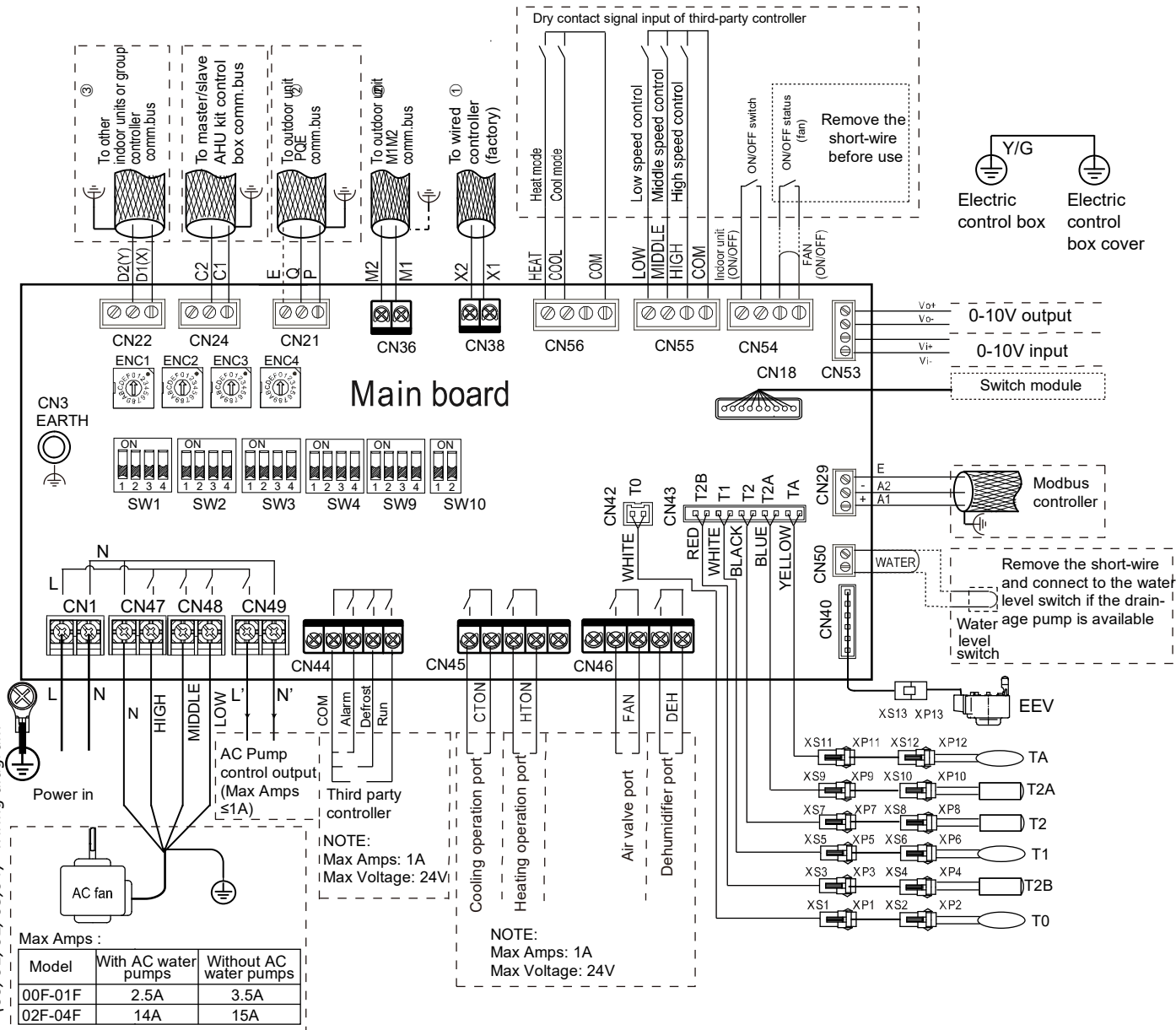


- The ODU and AHU Kit should use separate power supplies with rated voltage. However, the AHU Kit and other AHUs in the same system should use the same power.
- The external power supply to the air conditioner should have ground wiring, which is linked to the ground wiring of the AHU Kit and ODU.
- The wiring work should be completed by qualified persons according to circuit drawing.
- The fixed connecting lines must be equipped with at least 3 mm of electric shock spacing.
- A leakage protector should be installed in accordance with the local electrical standard.
- Be sure to properly locate the power wiring and the signal wirings to avoid causing cross-disturbance and their contact with the connecting pipe or stop valve body. Generally, do not twist two wirings together unless the joint is well-soldered and covered with insulator tape.
- Do not turn on the power until the electrical wiring have been correctly completed.

### 11.10.1 Wiring Diagram

#### SAHK-00 / SAHK-01 / SAHK-02/SAHK-03/ SAHK-04

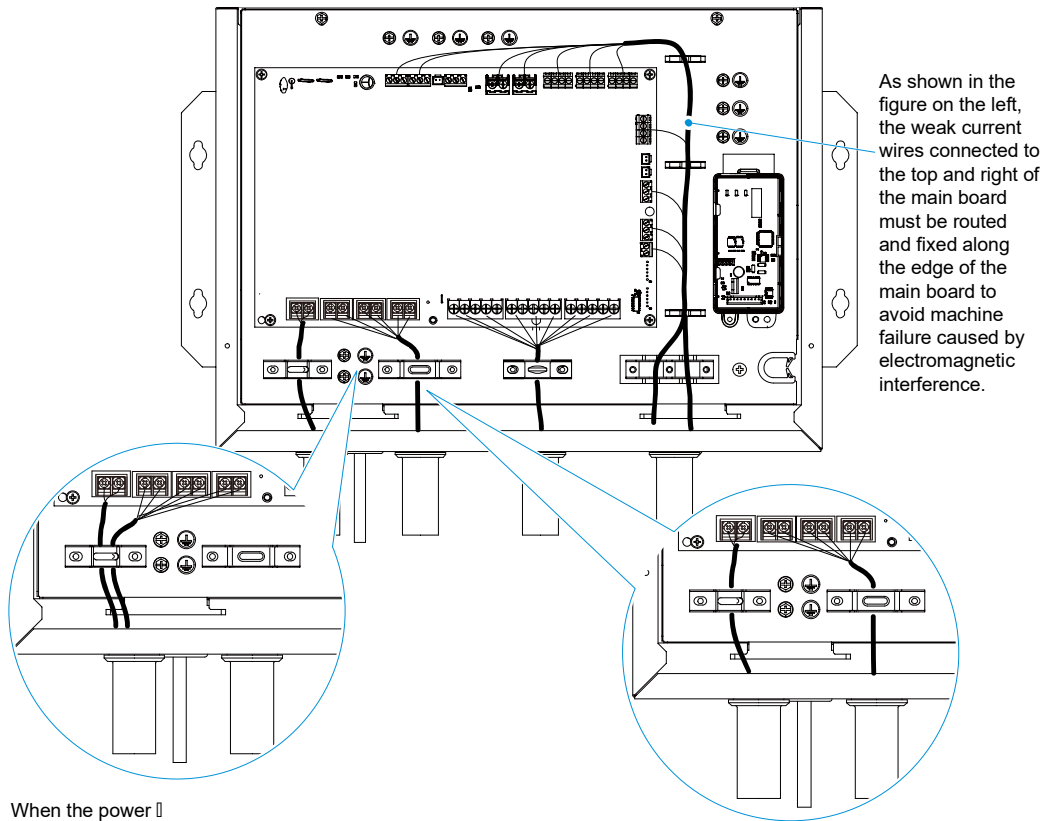
Figure 11-10.1 SAHK - (00, 01, 02, 03, 04) wiring diagram



### 11.10.2 Wiring inside the Electric Kit

For connections to the AHU Kit: Pull the wires inside through the screw nut and fasten the nut firmly to ensure a good pull relief and water protection.

The cables require an additional pull relief. Strap the cable with the installed tie wrap.



As shown in the figure on the left, the weak current wires connected to the top and right of the main board must be routed and fixed along the edge of the main board to avoid machine failure caused by electromagnetic interference.

When the power supply cable diameter  $\leq 1.5 \text{ mm}^2$ : Press the power supply cable or fan wire into the first cable clamp to avoid pulling and loosening the power supply cable.

When the power supply cable diameter  $> 1.5 \text{ mm}^2$ : Divide power supply cables and fan wires into different cable clamps to avoid unclamped cables and wires, resulting in loosened power supply cables.

#### Notes for installers

- The connection with the terminal block must be secure. Failure to do so may result in heating due to poor contact, and even fire in serious cases.
- The power cable and the communication cable should be separated by at least 50 mm to prevent electromagnetic interference.
- The position of the outlet hole must be tightened to prevent insects from entering.
- Connect the cables to the electric control board in accordance with the circuit diagram shown



Connect the cables to the electric control board in accordance with the circuit diagram shown in Figure:

No.	Port code		Function	Specification
1	CN1	L N	PCB power supply input	220-240 V~
2	CN47-2	HIGH	Fan speed power input-HIGH	220-240 V~
3	CN48-1	MIDDLE	Fan speed power input-MIDDLE	220-240 V~
	CN48-2	LOW	Fan speed power input-LOW	220-240 V~
4	CN49	PUMP	Pump running signal output	220-240 V~
5	CN44-3 (CN44-2 is a point of common coupling)	Alarm	ALARM output	Depends on the access device (accessible voltage: 0–24 V AC/DC, maximum current: 1 A)
	CN44-4 (CN44-2 is a point of common coupling)	Defrost	Defrosting status output	Depends on the access device (accessible voltage: 0–24 V AC/DC, maximum current: 1 A)
	CN44-5 (CN44-2 is a point of common coupling)	Run	Running status output	Depends on the access device (accessible voltage: 0–24 V AC/DC, maximum current: 1 A)
6	CN45-1, CN45-2	CTON	Feedback output in Cool mode	Depends on the access device (accessible voltage: 0–24 V AC/DC, maximum current: 1 A)
	CN45-3, CN45-4	HTOM	Feedback output in Heat mode	Depends on the access device (accessible voltage: 0–24 V AC/DC, maximum current: 1 A)
	CN45-5, CN46-1	AUX	Reserved	Depends on the access device (accessible voltage: 0–24 V AC/DC, maximum current: 1 A)
7	CN46-2, CN46-3	FAN	Interlocked air valve signal output	Depends on the access device (accessible voltage: 0–24 V AC/DC, maximum current: 1 A)
	CN46-4, CN46-5	DEH	Third-party dehumidifier output	Depends on the access device (accessible voltage: 0–24 V AC/DC, maximum current: 1 A)
8	CN40	EEV1	1# Electronic expansion valve	0 V or 12 V DC
9	CN50	WATER	Water level switch	0 V or 3.3 V DC
10	CN29	A1 A2 E	Connect to a Modbus protocol controller provided by a third party	5 V DC
11	CN53-1 (positive), CN53-2 (negative)	0–10V output	0–10V output	0~10 V DC
	CN53-3 (positive), CN53-4 (negative)	0–10V input	0–10V input	0~10 V DC
12	CN54-1, CN54-2(GND)	Indoor unit (ON/OFF)	Remote ON/OFF input	0 V or 12 V DC
	CN54-3, CN54-4(GND)	FAN (ON/OFF)	Fan ON/OFF input	0 V or 12 V DC
13	CN55-1 (CN55-4 is a point of common coupling)	LOW	Fan speed input-LOW	0 V or 12 V DC
	CN55-2 (CN55-4 is a point of common coupling)	MIDDLE	Fan speed input-MIDDLE	0 V or 12 V DC
	CN55-3 (CN55-4 is a point of common coupling)	HIGH	Fan speed input-HIGH	0 V or 12 V DC

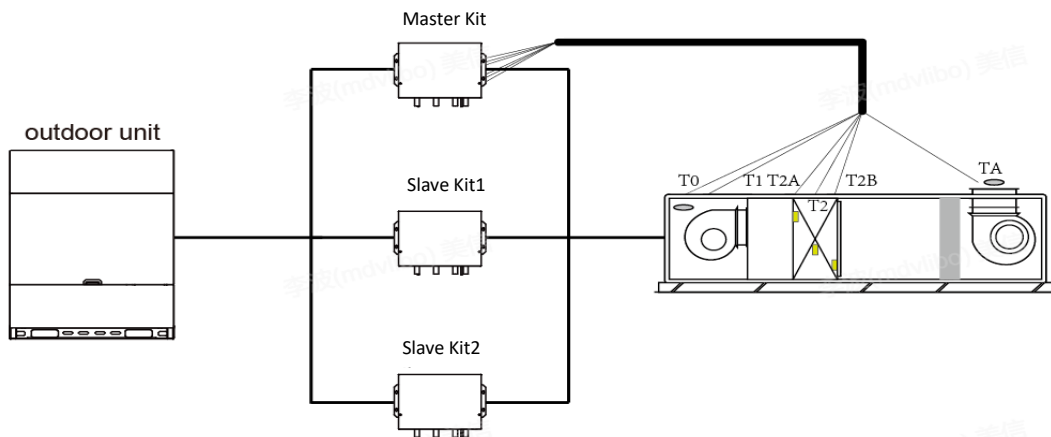
No.	Port code		Function	Specification
14	CN56-1 (CN56-4 is a point of common coupling)	HEAT	Mode input-HEAT	0 V or 12 V DC
	CN56-2 (CN56-4 is a point of common coupling)	COOL	Mode input-COOL	0 V or 12 V DC
	CN56-3 (CN56-4 is a point of common coupling)	FAN	Reserved	0 V or 12 V DC
15	CN38	X1 X2	Connect to the X1X2 port of wired controller supplied by factory	18 V DC
16	CN36	M1 M2	Connect to the outdoor unit M1M2 port	24 V DC
17	CN21	P Q E	Connect to the outdoor unit P/Q/E port	2.5-2.7 V DC
18	CN24	C1 C2 E	Port for connecting the master and slave units	2.5-2.7 V DC
19	CN22	D1(X) D2(Y) E	Connect to the main wired controller supplied by factory	2.5-2.7 V DC
21	CN43-10, CN43-9 (power supply)	TA	TA temperature sensor	0-3.3 V DC (varying)
	CN43-2, CN43-1 (power supply)	T2B	T2B temperature sensor	0-3.3 V DC (varying)
	CN43-4, CN43-3 (power supply)	T1	T1 temperature sensor	0-3.3 V DC (varying)
	CN43-6, CN43-5 (power supply)	T2	T2 temperature sensor	0-3.3 V DC (varying)
	CN43-8, CN43-7 (power supply)	T2A	T2A temperature sensor	0-3.3 V DC (varying)
22	CN42 (CN42-1: power supply)	T0	T0 temperature sensor	0-3.3 V DC (varying)
23	CN30	DISPLAY	Port to connect the display box	12 V DC
24	CN18	Extend	Port to connect the communication switch module	12 V DC
25	KEY1	KEY1	Spot check button	0-3.3 V DC

### 11.10.3 Temperature Sensor Wiring

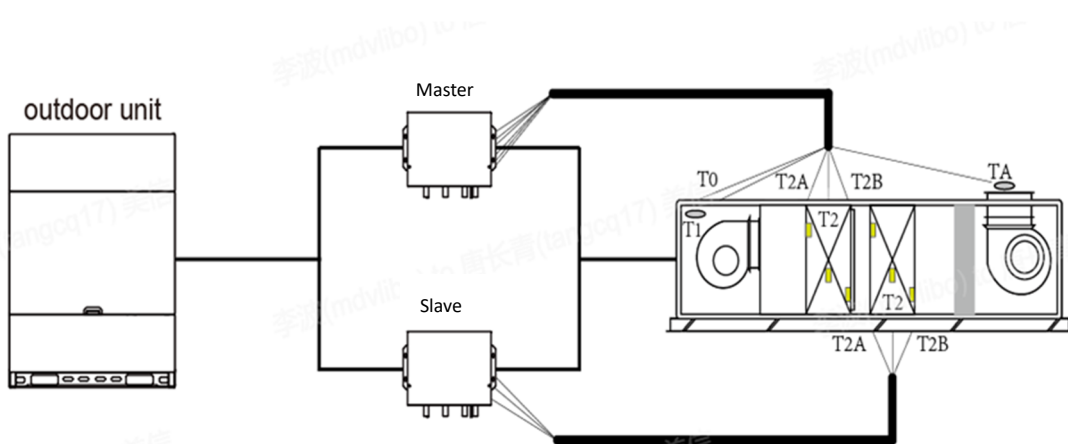
The temperature sensors come with two wiring methods, by dialing DIP switch SW9-2.

Type	SW9-2	Description
1		Connect a heat exchanger after parallel connection of Kit (Factory default)
2		Connect multiple heat exchangers in parallel with Kit

**Type 1:** The six temperature sensors (T1, TA, T0, T2, T2A, T2B) of AHU need to be connected to the master PCB, and the temperature sensor ports on the slave PCB need not be connected. See the following diagram for the connection diagram:



**Type 2:** The three air temperature sensors (T1, TA, T0) of AHU are connected to the master PCB, but not to the slave PCB. Three tube temperature sensors (T2, T2A, T2B) on each heat exchanger coil are respectively connected to the corresponding KitPCB, and the connection diagram is shown below:



## Caution Notes



- Specific wiring requirements must adhere to local wiring regulations.
- Use only copper wires.
- Be sure to use specified wires for connections and ensure that no external force is imparted to terminal connections. If connections are not firmly secured, overheating or fires may result.
- The wire size is the minimum value for metal conduit wiring. If the voltage drops, use a wire that is one rank thicker in diameter. Make sure the power-supply voltage does not drop by more than 10%.
- Power must be unified supply to all AHU Kites in the same system
- A breaker for current leakage must be attached to the power supply. If no ground leakage breaker is installed, it may cause electrical shock
- Do not use anything other than a breaker and fuse with the correct capacity. Using a fuse or wire of too large capacity may cause malfunction or fire

### 11.10.4 Connection of Power Supply Cables and Fan Wires

#### Cable diameter selection:

Rated current (A)	Nominal cross-sectional area (mm <sup>2</sup> )	
	Soft wire	Hard wire
≤ 3	0.5 and 0.75	1 and 2.5
> 3 and ≤ 6	0.75 and 1	1 and 2.5
> 6 and ≤ 10	1 and 1.5	1 and 2.5
> 10 and ≤ 16	1.5 and 2.5	1.5 and 4
> 16 and ≤ 25	2.5 and 4	2.5 and 6
> 25 and ≤ 32	4 and 6	4 and 10
> 32 and ≤ 50	6 and 10	6 and 16
> 50 and ≤ 63	10 and 16	10 and 25

#### Circuit breaker selection:

Total current	Circuit breaker (A)
Below 5 A	6
6~8 A	10
9~14 A	16
15~18 A	20
19~22 A	25
23~29 A	32
30~36 A	40
37~45 A	50
46~57 A	63

**Note:** The above table is a recommended value. If the value conflicts with the local regulations, select the cable diameter and circuit breaker based on the local regulations.

#### Fan speed control port CN47 and CN48 electrical parameter:

Model	Maximum load current (with AC water pumps)	Maximum load current (without AC water pumps)
SAHK-00~01	2.5A	3.5A
SAHK-02~04	14A	15A

#### Fan signal:

The AHU Kit has two output modes to control fan speed: a signal output LOW/MIDDLE/HIGH and an output of 0-10V, respectively. The output mode is selected based on the actual on-site needs of the AHU.

Table 11-10.2

Fan Signal	LOW/ MIDDLE/HIGH	0-10V output
Low	LOW	ENC2
Middle	MIDDLE	ENC3
High	HIGH	ENC4

Note: \*Refer to 0-10V output control


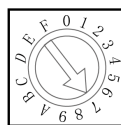
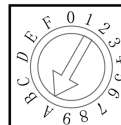
## 0-10V output control

The DIP switch numbers of ENC2, ENC3 and ENC4 correspond to different voltage outputs. Depending on the DIP switch numbers of SW1-2, there are two control modes available.

### 1. SW1-2 dialled to "0" (by default)

When ENC2/ENC3/ENC4 DIP switches are used to set the 0–10 V fan speed signal output voltage value,  $\alpha < \beta < \delta$ . See the table below for their corresponding relations:

Table 11-10.3

$\alpha$ Set DIP Switch: ENC2		$\beta$ Set DIP Switch: ENC3		$\delta$ Set DIP Switch: ENC4			
	Default DIP value: 2		Default DIP value: 7		Default DIP value: A		
Mapping table of Output Voltage Values $\alpha$ , $\beta$ , $\delta$ and DIP Values							
DIP value	0-10V	DIP value	DIP value	DIP value	DIP value	DIP value	DIP value
0	0.5	4	4.0	8	8.0	C	10.0
1	1.0	5	5.0	9	9.0	D	10.0
2	2.0	6	6.0	A	10.0	E	10.0
3	3.0	7	7.0	B	10.0	F	10.0

### Notes for installers



ENC2<ENC3<ENC4. If not satisfied, fault U15 is reported.

### 2. SW1-2 dialled to "1"

This indicates that the fan has only one fan speed. In this case, ENC2 indicates the fan speed while ENC3 indicates a 0-10V output voltage for the corresponding gear. ENC4 is not defined

Table 11-10.4

ENC2 DIP	Fan Speed	LOW/MIDDLE/HIGH	0-10V output
0	Low only	LOW output	ENC3 voltage
1	Medium only	MIDDLE output	ENC3 voltage
2 (by default)	High only	HIGH output	ENC3 voltage
3-F	High only	HIGH output	ENC3 voltage

Corresponding voltage for the ENC3 DIP switch:

Table 11-10.5

Dial Code	0	1	2	3	4	5	6	7	8	9	A	B	C	D	E	F
Voltage	0.5	1	2	3	4	5	6	7	8	9	10	10	10	10	10	10

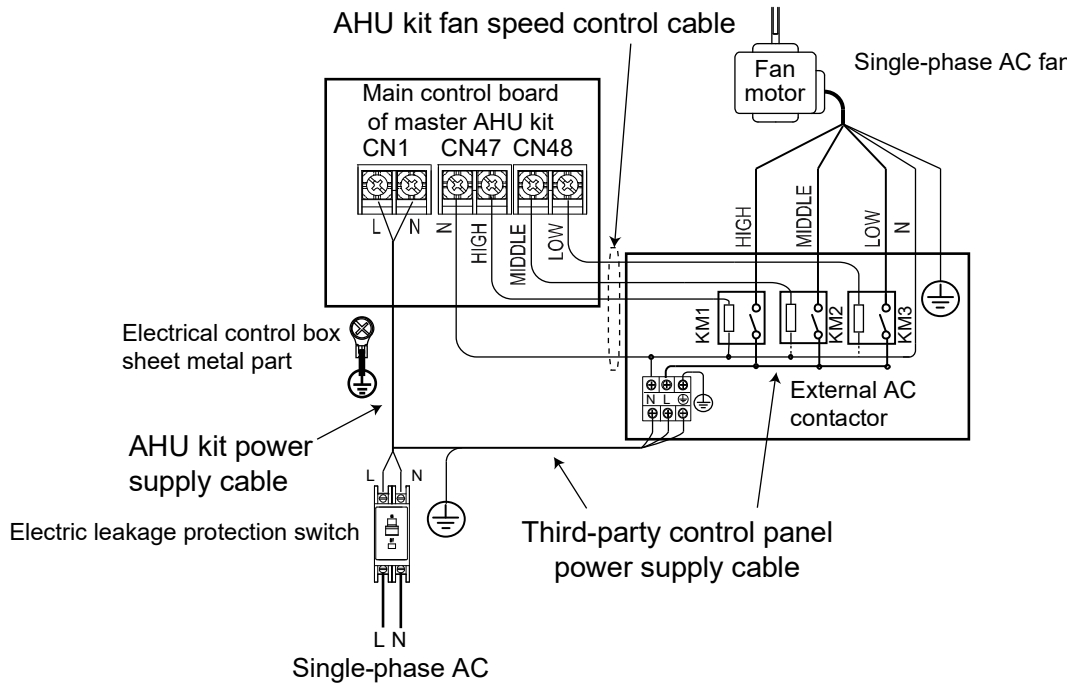
Wiring between the terminal block and fan

The sum current of the drain pump and fan motor should not be greater than 3.5A in models SAHK-00 and SAHK-01. The current of the drain pump and fan motor should not be greater than 15A in models SAHK-02 and SAHK-04.

Indirect drive the single-phase AC fan: The Kit power connector and fan connector are both fixed on the main control

board. This wiring scheme must be used when the maximum fan current is greater than the maximum load current of the kit.

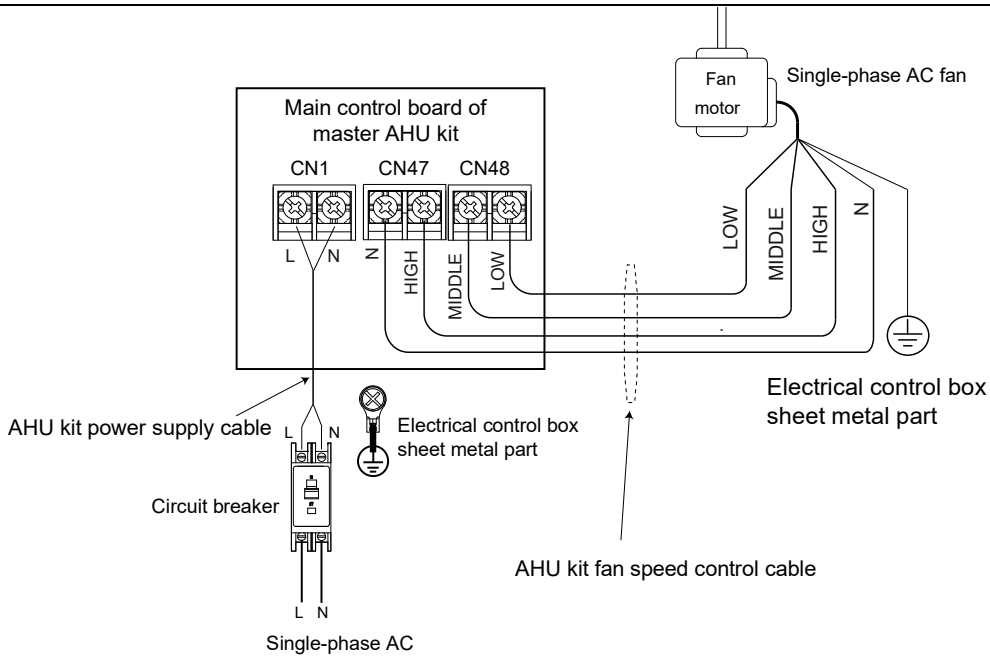
Select wires with appropriate diameters according to the following table and connect them with circuit breakers according to the following figure.



Type	SAHK-00~04
AHU kit power supply cable specifications	3×1.0 mm <sup>2</sup>
AHU kit fan speed control cable specifications	3×1.0 mm <sup>2</sup>
Third-party control panel power supply cable specifications	Refer to the Table of Selection of Line Diameter based on the maximum current of the fan
Circuit breaker specifications	Refer to the Table of Selection of Circuit Breaker based on the maximum current of the fan

Direct drive single-phase AC fan: The Kit power connector and fan connector are both fixed on the main control board. This wiring scheme can be used when the maximum fan current is not greater than the maximum load current of the kit.

Select wires with appropriate diameters according to the following table and connect them with circuit breakers according to the following figure.



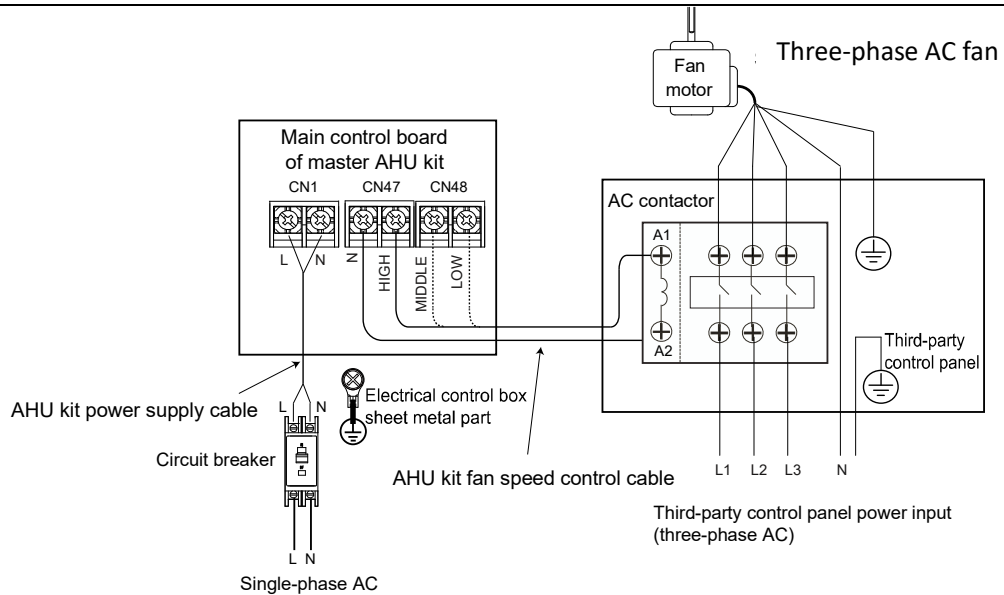
Type	SAHK-00~04
AHU kit power supply cable specifications	Refer to the Table of Selection of Line Diameter based on the maximum current of the fan
AHU kit fan speed control cable specifications	
Electric leakage protection switch specifications	Refer to the Table of Selection of Circuit Breaker based on the maximum current of the fan

If the fan motor is a 3-Phase AC motor, SW1-2 must be set to "ON", and the ENC2 must be dialled to "2". The fan terminal block only supports high-speed output.

SW1, ENC2	
	Only high-speed is available

Indirectly driven three-phase AC fan: The Kit power connector and fan connector are both fixed on the main control board. Select the appropriate wire diameter and circuit breaker according to the following table, and connect them according to the following schematic diagram.

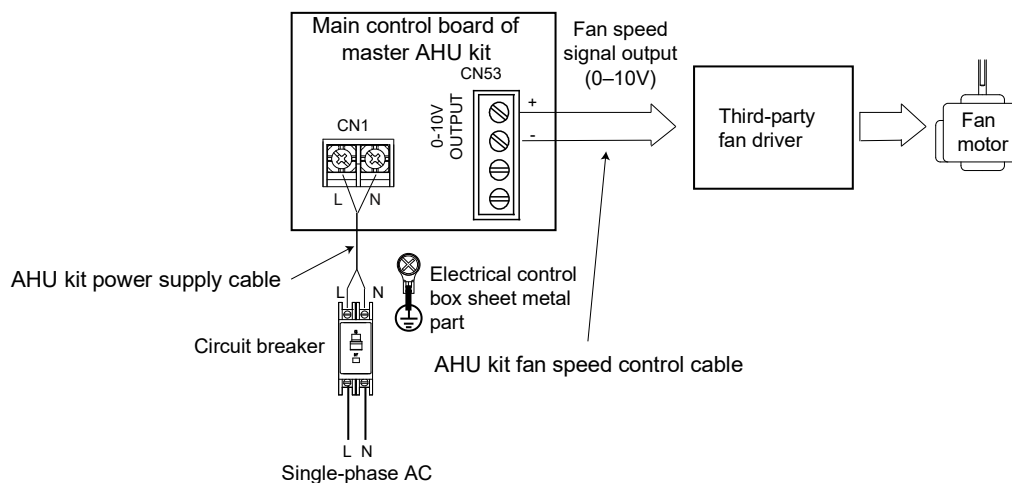
Select wires with appropriate diameters according to the following table and connect them with circuit breakers according to the following figure.



Type	SAHK-00~04
AHU kit power supply cable specifications	3×1.0 mm <sup>2</sup>
AHU kit fan speed control cable specifications	3×1.0 mm <sup>2</sup>
Third-party control panel power supply cable specifications	Refer to the Table of Selection of Line Diameter based on the maximum current of the fan
Circuit breaker specifications	Refer to the Table of Selection of Circuit Breaker based on the maximum current of the fan

The AHU kit outputs 0–10V DC fan speed signal only to the third-party fan driver to control the fan speed: The power connector of the Kit and the connector for the 0-10V DC voltage signal output are both fixed on the main control board.

Select wires with appropriate diameters according to the following table and connect them with circuit breakers according to the following figure.



Type	SAHK-00~04
AHU kit power supply cable specifications	3×1.0 mm <sup>2</sup>
0–10V DC fan speed signal cable specifications	2×0.75 mm <sup>2</sup>
Third-party control panel power supply cable specifications	Refer to the Table of Selection of Line Diameter based on the maximum current of the fan
Circuit breaker specifications	6A

## Notes for installers



- The rated current of the contactor must be greater than the current of the motor.
- The control power of the contactor must be the same as the input power of the AHU Kit.
- SW1-2 must be set to "ON".
- ENC2 must be dialed to "2".

### 11.10.5 Signal Cable Connection

The following figure displays the signal cable connection diagram:

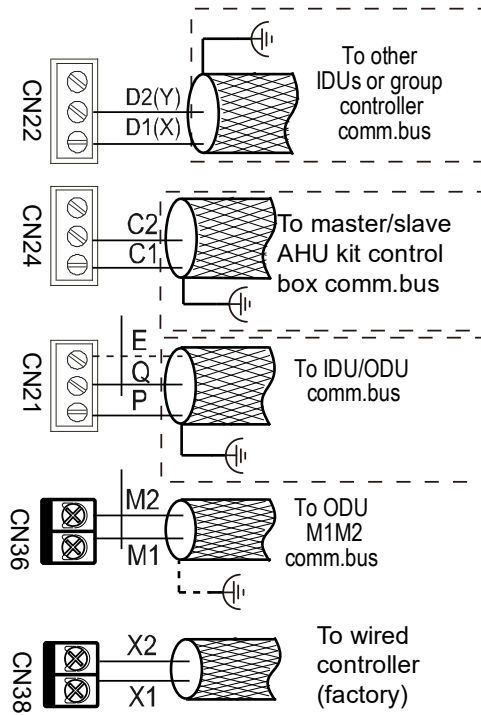


Figure 3-20




## 11.11 Capacity Settings


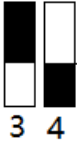

The capacity DIP switches for the AHU Kit should be set after the box is installed.

The combination of disc dial ENC1 and dial switch SW9-3/SW9-4 on PCB can set the capacity of Kit. After completing the settings, power off and then power on the unit to apply the settings.

**Note:** Capacity settings must be done for each AHU Kit in parallel connection

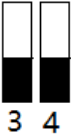

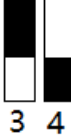

Table 4-1 Capacities of SW9-3/SW9-4 and ENC1

Disc switch: ENC1	Dip switch : SW9-3 / SW9-4							
								
Number	Nominal cooling capacity		addresses		Nominal cooling capacity		addresses	
	HP	KW	real addresses	virtual addresses	HP	KW	real addresses	virtual addresses
0	0.8	1.8/2.2	Settings	non-existent	10	28.0	Settings	Settings+1
1	1.0	2.5/2.8	Settings	non-existent	12	33.5	Settings	Settings+1
2	1.2	3.2/3.6	Settings	non-existent	14	40.0	Settings	Settings+1 Settings+2 Settings+3
3	1.7	4.0/4.5	Settings	non-existent	16	45.0	Settings	Settings+1 Settings+2 Settings+3
4	2.0	5.0/5.6	Settings	non-existent	18	50.0	Settings	Settings+1 Settings+2 Settings+3
5	2.5	6.3/7.1	Settings	non-existent	20	56.0	Settings	Settings+1 Settings+2 Settings+3
6	3.0	8.0	Settings	non-existent	22	61.5	Settings	Settings+1 Settings+2 Settings+3
7	3.2	9.0	Settings	non-existent	24	67.0	Settings	Settings+1 Settings+2 Settings+3
8	3.6	10.0	Settings	non-existent	26	73.0	Settings	Settings+1 Settings+2 Settings+3
9	4.0	11.2	Settings	non-existent	28	78.5	Settings	Settings+1 ..... Settings+4
A	4.5	12.0/12.5	Settings	non-existent	30	85.0	Settings	Settings+1 ..... Settings+4
B	5.0	14.0	Settings	non-existent	32	90.0	Settings	Settings+1 ..... Settings+4
C	6.0	16.0	Settings	non-existent	34	95.0	Settings	Settings+1 ..... Settings+5
D(Factory default)	6.5	18.0	Settings	non-existent	36	101.0	Settings	Settings+1 ..... Settings+5
E	7.0	20.0	Settings	Settings+1	38	106.0/108.0	Settings	Settings+1 ..... Settings+7
F	8.0	25.2	Settings	Settings+1	40	112.0	Settings	Settings+1 ..... Settings+7


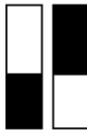


Disc switch: ENC1	Dip switch : SW9-3 / SW9-4							
	 3 4				 3 4 (Factory default)			
Number	Nominal cooling capacity		addresses		Nominal cooling capacity		addresses	
	HP	KW	real addresses	virtual addresses	HP	KW	real addresses	virtual addresses
0	42.0	117.0	Settings	Settings+1 ..... Settings+9	74.0	207.0	Settings	Settings+1 ..... Settings+15
1	44.0	123.0	Settings	Settings+1 ..... Settings+9	76.0	213.0	Settings	Settings+1 ..... Settings+15
2	46.0	128.5	Settings	Settings+1 ..... Settings+9	78.0	218.0	Settings	Settings+1 ..... Settings+15
3	48.0	134.0	Settings	Settings+1 ..... Settings+9	80.0	224.0	Settings	Settings+1 ..... Settings+15
4	50.0	141.0	Settings	Settings+1 ..... Settings+9	84.0	235.0	Settings	Settings+1 ..... Settings+15
5	52.0	146.0	Settings	Settings+1 ..... Settings+11	88.0	246.0	Settings	Settings+1 ..... Settings+15
6	54.0	151.5	Settings	Settings+1 ..... Settings+11	92.0	258.0	Settings	Settings+1 ..... Settings+15
7	56.0	157.0	Settings	Settings+1 ..... Settings+11	96.0	269.0	Settings	Settings+1 ..... Settings+15
8	58.0	162.5	Settings	Settings+1 ..... Settings+11	100.0	280.5	Settings	Settings+1 ..... Settings+15
9	60.0	168.0	Settings	Settings+1 ..... Settings+11	104.0	292.0	Settings	Settings+1 ..... Settings+15
A	62.0	173.5	Settings	Settings+1 ..... Settings+13	108.0	303.0	Settings	Settings+1 ..... Settings+17
B	64.0	179.0	Settings	Settings+1 ..... Settings+13	112.0	314.0	Settings	Settings+1 ..... Settings+17
C	66.0	185.0	Settings	Settings+1 ..... Settings+13	116.0	325.0	Settings	Settings+1 ..... Settings+17
D(Factory default)	68.0	191.0	Settings	Settings+1 ..... Settings+13	120.0	336.0	Settings	Settings+1 ..... Settings+19
E	70.0	196.0	Settings	Settings+1 ..... Settings+13	120.0	336.0	Settings	Settings+1 ..... Settings+19
F	72.0	202.0	Settings	Settings+1 ..... Settings+15	120.0	336.0	Settings	Settings+1 ..... Settings+19

## 11.12 Setting the Master/ Slave AHU Kit

1. When Kit is connected in parallel, the combination of dip switch SW2-3/SW2-4 on PCB can set master/slave.

Dip switch	Master AHU kit (Factory default)	Salve AHU kit 1#	Salve AHU kit 2#	Salve AHU kit 3#
SW2-3 /SW2-4				

2. SW1-3/SW1-4 combination on the master PCB can set the number of slaves.

Dip switch	Only Master AHU kit (Factory default)	Master AHU kit + 1 Salve AHU kit	Master AHU kit + 2 Salve AHU kit	Master AHU kit + 3 Salve AHU kit
SW1-3 /SW1-4 (Only the Master AHU kit settings are valid)				

**Note:** The number of slave AHU Kites connected in parallel can only be set from the main board of the master AHU Kit.

### 11.13 Address Setting of AHU Kit

When powering-on for the first time, If the address is not set, the wired controller will display fault U38. The ODU can use auto-addressing to set the address for an AHU Kit which does not have an address.

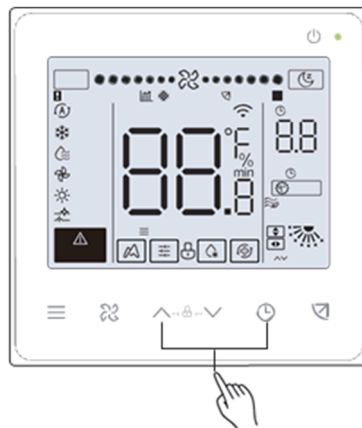
Only the master AHU Kit communicates with the ODU. Therefore, only the address of master AHU Kit needs to be set via the wired controller.

Take the SWC-61F wired controller in the accessory package as an example: The parameters can be set when the wired controller is ON or OFF.

1. Hold TIMER + Up for 5 seconds at the same time to enter the indoor unit address query and setting interface, if the AHU kit has an address, the current address will be displayed, if there is no address, "FE" will be displayed.

2. Press SWING, and the number area flashes; press UP and DOWN to switch the address, and then press SWING to confirm the setting.

3. The wired controller will automatically exit the address setting page if no operation is performed for 60s, or you can press TIMER to exit the address setting page.



**Note:** The address of the same system cannot be repeated.

When the AHU Kit is set to have a capacity of over 18 kW, a virtual address will be generated. The virtual address is equivalent



to the actual address and occupies the address bit. When setting the address, do not set the actual address to a virtual address that is already occupied.

Kit addresses can be divided into real addresses and virtual addresses, with only one real address, and the number of virtual addresses depends on the nominal capacity of Kit. For the mapping between the actual and virtual addresses of each capacity segment, see Capacity and Address Settings.

If there are several parallel AHU Kit systems in one refrigerant system, calculate the number of occupied virtual addresses for each parallel AHU Kit system, and set the actual address of each parallel AHU Kit system to avoid repetition of actual addresses and virtual addresses.

**11.13.1 Selection of control by return air temperature**







An AHU Kit can select the control by either return air temperature or by outlet air temperature via SW4-1.

Dip switch	Return air temperature control (by default)	Supply air temperature control
SW4-1	 1↔	 1↔

When return air temperature control is selected, the return air temperature sensor must be connected; when outlet air temperature control is selected, both the return air temperature sensor and outlet air temperature sensor must be connected.

## 12 Selection of Controllers

The factory controller or a third party controller can be selected for the AHU Kit. The type of controllers can be selected through SW2-2, SW4-3 and SW4-4.

Controller	SW2-2	SW4-3/SW4-4
Factory controller (Factory default)	 2	 3 4
Third party controller capacity levels setting	 2	 3 4
Third party controller temperature setting	 2	 3 4

**Note:**

1. After DIP switches on main board are set, remember to power off and then power on the main board to apply the settings. Otherwise, the settings will be invalid.
2. When a third party controller is used, two control modes are available: capacity output control mode and set temperature control mode.

## 12.1 Factory Controller

When the factory controller is selected, the AHU Kit can be controlled by the factory wired controller or remote controller.

The factory wired controller in the accessories is connected to X1 and X2 ports on the main board.

Only the master AHU Kit communicates with the ODU. As a result, when AHU Kites are connected in parallel, the factory wired controller only needs to be connected to X1 and X2 of the master AHU Kit.

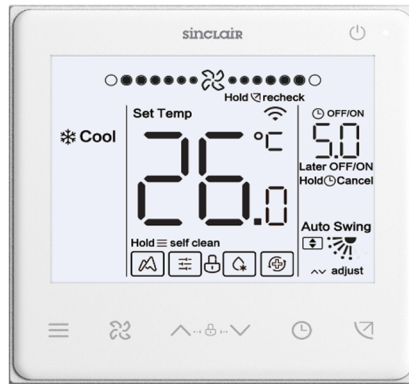


Figure 5-1 Factory wired controller

For detailed instructions for the wired controller, refer to the wired controller installation & owner’s manual.

**Note:** When the factory controller mode is applied, the main board of the AHU Kit will not respond to the control signal from a third party controller.

### 12.1.1 Setting Capacity Output Mode via Third party controller (Type 1)

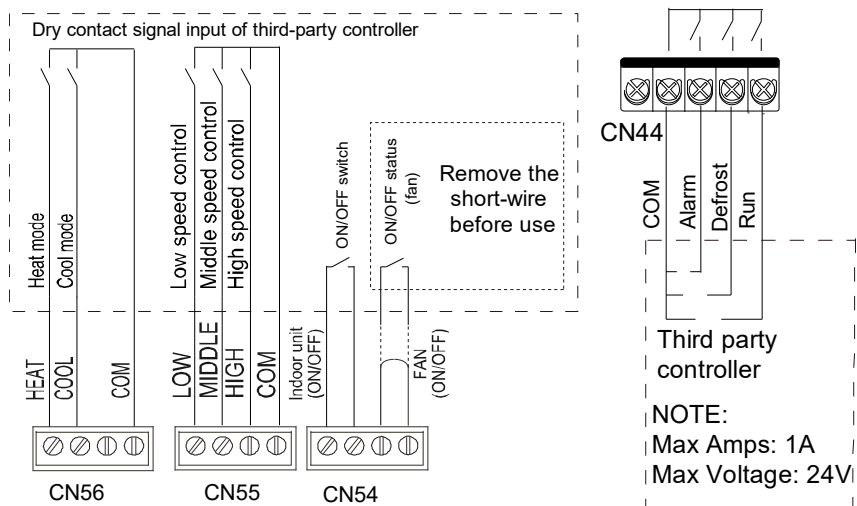
When capacity setting with a third party controller mode has been selected, only the third party controller can be used to control the AHU Kit. The signal from the factory controller will not respond except to the address setting and inquiring signal.

Even if capacity setting with third party controller mode has been selected, a factory remote controller or wired controller is needed to set the address for the AHU Kit, because the third party controller does not have this function.

### Wiring figure

Please refer to the wiring diagram. Pay careful attention to the following three things:

1. The distance between the third party controller and the AHU Kit depends on the external device that is connected (controller/relay...)
2. If several AHU Kites in a parallel connection control one AHU, the third party controller only needs to be connected with the master AHU Kit.
3. One third party controller cannot control two or more AHU at the same time.



## Mode Control

Controller type	Temperature control type	Supported running mode		
Factory supplied controller	Return air temperature control	Cool, Dry, Heat, Fan		
	Supply air temperature control	Cool, Heat, Fan		
Third-party controller	Return air temperature control	The third-party controller is connected to the input dry contact (CN56) in running mode on the main control PCB, and the output running mode is executed according to the following table:		
		Dry contact state		Output running mode
	Cooling dry contact	Heating dry contact		
	Supply air temperature control	Open	Open	Shutdown
		Close	Open	Cool
		Open	Close	Heating
		Close	Close	Heating

### Operation at 0-10V capacity output

This control mode requires a third party controller equipped with a temperature sensor that is used to control the following temperatures:

1. Return air temperature of the AHU
2. Outlet air temperature of the AHU

0-10 V input voltage and capacity range, capacity demand value corresponding table:

0-10 V input voltage and capacity gear back difference diagram	Capacity range and capacity demand value			
	Capacity gear	Capacity requirement sent to the outdoor unit		
		Connect SDV5 series heat pump / single cooling outdoor unit	Connect the SDV6 series outdoor unit	
		Cooling/heating	Cooling(default)	Heating(default)
	Interval a	100%	Te = 5 °C	Tc = 46 °C
	Interval b	90%	Te = 6 °C	Tc = 44 °C
	Interval c	80%	Te = 7 °C	Tc = 42 °C
	Interval d	70%	Te = 8 °C	Tc = 40 °C
	Interval e	60%	Te = 9 °C	Tc = 38 °C
	Interval f	50%	Te = 10 °C	Tc = 36 °C
	Interval g	40%	Te = 11 °C	Tc = 34 °C
	Interval h	30%	Te = 12 °C	Tc = 32 °C
	Interval i	20%	Te = 13 °C	Tc = 30 °C
	Interval j	10%	Te = 14 °C	Tc = 28 °C
Interval k	Thermo OFF	Thermo OFF	Thermo OFF	
<p>Y1/M-V: 0-10 V input voltage received by the host</p> <p>a-k: indicates the capacity range</p> <p>Voltage change: up direction ≥, down direction &lt;</p>	<p>HP: Total DIP switch capacity of the master and slave</p> <p>10 %-100 %: The percentage of capacity requirement sent to outdoor units</p> <p>Te: Target evaporation temperature; Tc: target condensation temperature</p>			

### Operation Instruction

When the third party controller has been selected, AHU Kit will operate according to the control signal from the third party controller and output alarm, defrost and run status signal.

#### 12.1.2 Setting Temperature Mode via third party controller (Type 2)

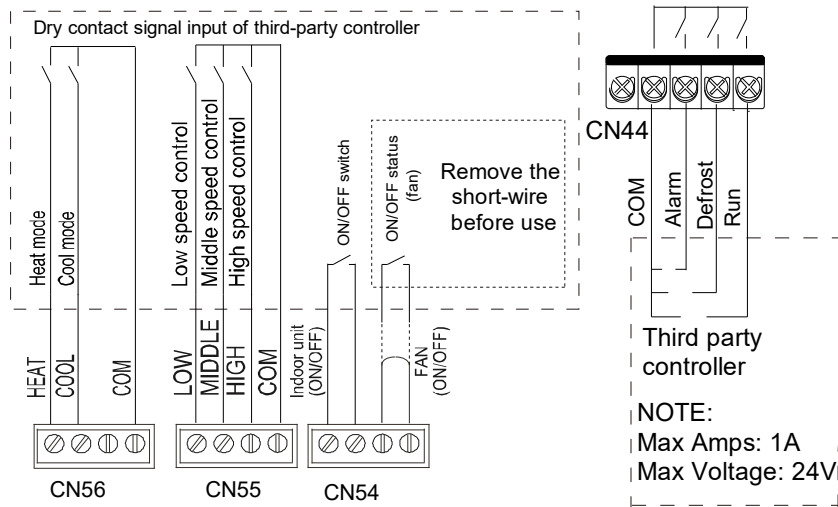
When temperature is controllable by a third party controller, the AHU Kit does not respond to instructions from the factory controller except for address setting and query.

Even if temperature control by a third party controller is applied, a factory controller is still needed to set the address because the third party controller cannot do so

#### Third party controller wiring

Please refer to the wiring diagram. Pay careful attention to the following three things:

1. The distance between the third party controller and the AHU Kit depends on the external device that is connected (controller/relay...)
2. If several AHU Kites in parallel connection control one AHU, the third party controller only needs to be connected with the master AHU Kit.



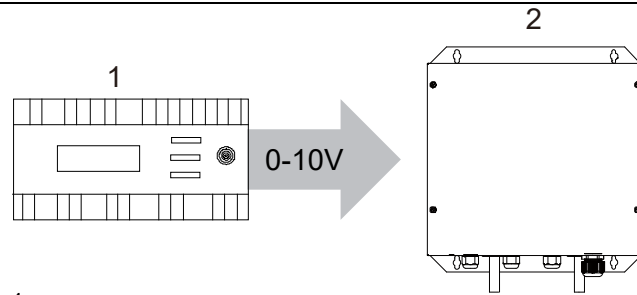
3. One third party controller can't control two or more AHUs at the same time.

**Mode Control**

Controller type	Temperature control type	Supported running mode		
Factory supplied controller	Return air temperature control	Cool, Dry, Heat, Fan		
	Supply air temperature control	Cool, Heat, Fan		
Third-party controller	Return air temperature control	The third-party controller is connected to the input dry contact (CN56) in running mode on the main control PCB, and the output running mode is executed according to the following table:		
		Dry contact state		Output running mode
	Cooling dry contact	Heating dry contact		
	Open	Open	Shutdown	
	Supply air temperature control	Close	Open	Cool
		Open	Close	Heating
Close		Close	Heating	

**Operation at 0-10V temperature output**

- The AHU Kit needs to be connected to the return air temperature sensor T1, and to be connected to the outlet air temperature sensor TA if the outlet air temperature control is selected.
- The third party controller sends a voltage signal of 0-10V to the AHU Kit. The AHU Kit converts the voltage of 0-10V into the target temperature TS, and calculates the temperature difference between the target temperature and the return temperature T1 or the outlet temperature TA detected by the AHU Kit. The temperature difference is used to regulate the system output.



- 1 Third party controller
- 2 AHU control box

Figure 5-3

1. Third party controller
2. AHU Kit

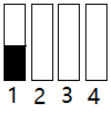


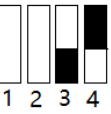


Third party controller - return air temperature control setting				
Normal	Voltage Range		Cooling Set Temperature (°C)	Heating Set Temperature (°C)
	Min.	Max.		
0.5	0	0.75	Not available	Not available
1	0.85	1.15	16	16
1.4	1.25	1.55	16	16
1.8	1.65	1.95	16	16
2.2	2.05	2.35	16	16
2.6	2.45	2.75	16	16
3	2.85	3.15	16	16
3.4	3.25	3.55	16	16
3.8	3.65	3.95	17	17
4.2	4.05	4.35	18	18
4.6	4.45	4.75	19	19
5	4.85	5.15	20	20
5.4	5.25	5.55	21	21
5.8	5.65	5.95	22	22
6.2	6.05	6.35	23	23
6.6	6.45	6.75	24	24
7	6.85	7.15	25	25
7.4	7.25	7.55	26	26
7.8	7.65	7.95	27	27
8.2	8.05	8.35	28	28
8.6	8.45	8.75	29	29
9	8.85	9.15	30	30
9.4	9.25	10	Not available	Not available

Third party controller - outlet air temperature control setting				
Normal	Voltage Range		Cooling Set Temperature (°C)	Heating Set Temperature (°C)
	Min.	Max.		
0.5	0	0.75	Non settable	Non settable
1	0.85	1.15	10	10
1.4	1.25	1.55	11	11
1.8	1.65	1.95	12	12
2.2	2.05	2.35	13	13
2.6	2.45	2.75	14	14
3	2.85	3.15	15	15
3.4	3.25	3.55	16	16
3.8	3.65	3.95	17	17
4.2	4.05	4.35	18	18
4.6	4.45	4.75	19	19
5	4.85	5.15	20	20
5.4	5.25	5.55	21	21
5.8	5.65	5.95	22	22
6.2	6.05	6.35	23	23
6.6	6.45	6.75	24	24
7	6.85	7.15	25	25
7.4	7.25	7.55	26	26
7.8	7.65	7.95	27	27
8.2	8.05	8.35	28	28
8.6	8.45	8.75	29	29
9	8.85	9.15	30	30
9.4	9.25	10	Non settable	Non settable

**Note:** The analog voltage must be between maximum and minimum value.

## 13 Dip Switch definitions

### 1) Definitions of each bit of SW1:

<p style="text-align: center;">ON</p>  <p style="text-align: center;">Valid for the master unit only</p>	<ul style="list-style-type: none"> <li>• SW1-1 is 0: shutdown compensation temperature (cooling) is 0°C (factory default)</li> <li>• SW1-1 is 1: shutdown compensation temperature (cooling) is 2°C (outlet air temperature control is invalid)</li> </ul>
<p style="text-align: center;">ON</p>  <p style="text-align: center;">Valid for the master unit only</p>	<ul style="list-style-type: none"> <li>• SW1-2 is 0: AHU Kit provides three fan speeds (factory default)</li> <li>• SW1-2 is 1: only one fan speed</li> </ul>
<p style="text-align: center;">ON</p>  <p style="text-align: center;">Valid for the master unit only</p>	<ul style="list-style-type: none"> <li>• SW1-3 and SW1-4 are 00: the number of slave AHU Kites connected in parallel is 0 (factory default); valid for the master unit</li> </ul>
<p style="text-align: center;">ON</p>  <p style="text-align: center;">Valid for the master unit only</p>	<ul style="list-style-type: none"> <li>• SW1-3 and SW1-4 are 01: the number of slave AHU Kites connected in parallel is 1</li> </ul>
<p style="text-align: center;">ON</p>  <p style="text-align: center;">Valid for the master unit only</p>	<ul style="list-style-type: none"> <li>• SW1-3 and SW1-4 are 10: the number of slave AHU Kites connected in parallel is 2</li> </ul>
<p style="text-align: center;">ON</p>  <p style="text-align: center;">Valid for the master unit only</p>	<ul style="list-style-type: none"> <li>• SW1-3 and SW1-4 are 11: the number of slave AHU Kites connected in parallel is 3</li> </ul>

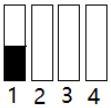




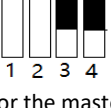
2) Definitions of each bit of SW2:

<p>ON</p> <p>1 2 3 4</p>	<ul style="list-style-type: none"> <li>SW2-1 is reserved</li> </ul>
<p>ON</p> <p>1 2 3 4</p>	<ul style="list-style-type: none"> <li>SW2-2 is 0 and SW4-3, SW4-4 is 00: Energy demand/fan speed/mode all adopt Sinclair controller mode.</li> </ul> <p>SW2-2 is 0 and SW4-3, SW4-4 is 01:</p> <ul style="list-style-type: none"> <li>Energy demand: input energy demand gear value 0-10V 0-10V through third-party controller.</li> <li>Fan speed: input fan speed dry contact signal mode through third-party controller.</li> <li>Mode: Input mode dry contact signal through third-party controller</li> </ul> <p>SW2-2 is 0 and SW4-3, SW4-4 is 10:</p> <ul style="list-style-type: none"> <li>Energy demand: input set temperature value 0-10V through third-party controller.</li> <li>Fan speed: input fan speed dry contact signal mode through third-party controller.</li> <li>Mode: Input mode dry contact signal through third-party controller</li> </ul> <p>SW2-2 is 1 (reserved)</p> <ul style="list-style-type: none"> <li>Energy demand: Set temperature value or energy demand gear value through 0-10V input of third-party controller.</li> <li>Fan speed: input 0-10V fan speed through third-party controller.</li> <li>Mode: Input mode dry contact signal through third-party controller</li> </ul>
<p>ON</p> <p>1 2 3 4</p>	<ul style="list-style-type: none"> <li>SW2-3 and SW2-4 are 00: master AHU Kit</li> </ul>
<p>ON</p> <p>1 2 3 4</p>	<ul style="list-style-type: none"> <li>SW2-3 and SW2-4 are 01: slave AHU Kit 1</li> </ul>
<p>ON</p> <p>1 2 3 4</p>	<ul style="list-style-type: none"> <li>SW2-3 and SW2-4 are 10: slave AHU Kit 2</li> </ul>
<p>ON</p> <p>1 2 3 4</p>	<ul style="list-style-type: none"> <li>SW2-3 and SW2-4 are 11: slave AHU Kit 3</li> </ul>


### 3) Definitions of each bit of SW3:

	Return Air Temperature Control (SW4-1: 0)	Outlet Air Temperature Control (SW4-1: 1)
<p>ON</p> <p>Valid for the master unit only</p>	<ul style="list-style-type: none"> <li>SW3-1 and SW3-2 are 00: anti-cold air temperature value in heating mode, with fan closing temperature of 15 °C and fan opening temperature of 28 °C. (Factory default)</li> </ul>	<ul style="list-style-type: none"> <li>SW3-1 and SW3-2 are 00: anti-cold air temperature value in heating mode, with fan closing temperature of 5 °C and fan opening temperature of 10 °C. (Factory default)</li> </ul>
<p>ON</p> <p>Valid for the master unit only</p>	<ul style="list-style-type: none"> <li>SW3-1 and SW3-2 are 01: anti-cold air temperature value in heating mode, with fan closing temperature of 10 °C and fan opening temperature of 18 °C. (Factory default)</li> </ul>	<ul style="list-style-type: none"> <li>SW3-1 and SW3-2 are 01: anti-cold air temperature value in heating mode, with fan closing temperature of 5 °C and fan opening temperature of 12 °C. (Factory default)</li> </ul>
<p>ON</p> <p>Valid for the master unit only</p>	<ul style="list-style-type: none"> <li>SW3-1 and SW3-2 are 10: anti-cold air temperature value in heating mode, with fan closing temperature of 24 °C and fan opening temperature of 28 °C. (Factory default)</li> </ul>	<ul style="list-style-type: none"> <li>SW3-1 and SW3-2 are 10: anti-cold air temperature value in heating mode, with fan closing temperature of 5 °C and fan opening temperature of 14 °C. (Factory default)</li> </ul>
<p>ON</p> <p>Valid for the master unit only</p>	<ul style="list-style-type: none"> <li>SW3-1 and SW3-2 are 11: anti-cold air temperature value in heating mode is invalid</li> </ul>	<ul style="list-style-type: none"> <li>SW3-1 and SW3-2 are 11: anti-cold air temperature value in heating mode is invalid</li> </ul>
<p>ON</p> <p>Valid for the master unit only</p>	<ul style="list-style-type: none"> <li>SW3-3 and SW3-4 are 00: temperature compensation in heating mode is 6°C (factory default)</li> </ul>	<ul style="list-style-type: none"> <li>SW3-3 and SW3-4 are 00: Outlet air temperature control is invalid</li> </ul>
<p>ON</p> <p>Valid for the master unit only</p>	<ul style="list-style-type: none"> <li>SW3-3 and SW3-4 are 01: temperature compensation in heating mode is 2°C. (By Sinclair Controller)</li> </ul>	<ul style="list-style-type: none"> <li>SW3-3 and SW3-4 are 01: Outlet air temperature control is invalid. (By Sinclair Controller)</li> </ul>
<p>ON</p> <p>Valid for the master unit only</p>	<ul style="list-style-type: none"> <li>SW3-3 and SW3-4 are 10: temperature compensation in heating mode is 4°C.</li> </ul>	<ul style="list-style-type: none"> <li>SW3-3 and SW3-4 are 10: Outlet air temperature control is invalid.</li> </ul>
<p>ON</p> <p>Valid for the master unit only</p>	<ul style="list-style-type: none"> <li>SW3-3 and SW3-4 are 11: temperature compensation in heating mode is 0°C (Follow Me function)</li> </ul>	<ul style="list-style-type: none"> <li>SW3-3 and SW3-4 are 11: No temperature compensation for outlet air temperature control by default</li> </ul>



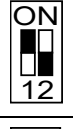
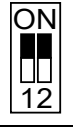

**4) Definitions of each bit of SW4:**

<p style="text-align: center;">ON</p>  <p style="text-align: center;">1 2 3 4</p> <p>Valid for the master unit only</p>	<ul style="list-style-type: none"> <li>• SW4-1 is 0: return air temperature control (factory default)</li> <li>• SW4-1 is 1: outlet air temperature control</li> </ul>
<p style="text-align: center;">ON</p>  <p style="text-align: center;">1 2 3 4</p>	<ul style="list-style-type: none"> <li>• SW4-2 indicates high bit (ON indicates + 16)</li> </ul>
<p style="text-align: center;">ON</p>  <p style="text-align: center;">1 2 3 4</p> <p>Valid for the master unit only</p>	<ul style="list-style-type: none"> <li>• SW4-3 and SW4-4 are 00: factory controller mode (factory default)</li> </ul>
<p style="text-align: center;">ON</p>  <p style="text-align: center;">1 2 3 4</p> <p>Valid for the master unit only</p>	<ul style="list-style-type: none"> <li>• SW4-3 and SW4-4 are 01: capacity output mode of a third party controller</li> </ul>
<p style="text-align: center;">ON</p>  <p style="text-align: center;">1 2 3 4</p> <p>Valid for the master unit only</p>	<ul style="list-style-type: none"> <li>• SW4-3 and SW4-4 are 10: set temperature control mode of a third party controller</li> </ul>
<p style="text-align: center;">ON</p>  <p style="text-align: center;">1 2 3 4</p> <p>Valid for the master unit only</p>	<ul style="list-style-type: none"> <li>• SW4-3 and SW4-4 are 11: set temperature control mode of a third party controller (reserved)</li> </ul>



5) Definitions of each bit of SW9:

 <p>Valid for the master unit only</p>	<ul style="list-style-type: none"> <li>• SW9-2 is 0: mode 1 of AHU Kit connecting to valve body in parallel (one coil is connected to multiple Kites; shielding faults from the slave unit's temperature sensors T1, T2, T2A, T2B and TA) (factory default)</li> <li>• SW9-2 is 1: mode 2 of the AHU Kit connecting to valve body in parallel (in the event of multiple coils, one coil is connected to one Kit; shielding faults from the slave unit's temperature sensor T1, TA)</li> </ul>
-------------------------------------------------------------------------------------------------------------------------	-----------------------------------------------------------------------------------------------------------------------------------------------------------------------------------------------------------------------------------------------------------------------------------------------------------------------------------------------------------------------------------------------------------------------------------------------------------------------------------------------

6) Definitions of each bit of SW10:

	<ul style="list-style-type: none"> <li>• 00: SAHK-00 model</li> </ul>
	<ul style="list-style-type: none"> <li>• 01: SAHK-01 model</li> </ul>
	<ul style="list-style-type: none"> <li>• 10: SAHK-02 model</li> </ul>
	<ul style="list-style-type: none"> <li>• 11: SAHK-03 model</li> </ul>
	<ul style="list-style-type: none"> <li>• 00: SAHK-04 model</li> </ul>

7) Definitions of J1:

	<ul style="list-style-type: none"> <li>• Without jumper; no short circuit indicates a power failure memory function (factory default)</li> </ul>
	<ul style="list-style-type: none"> <li>• With jumper, short circuit indicates no power failure memory function</li> </ul>

## 14 Error Code and Spot Check

### 14.1 Error Code Table



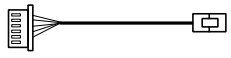
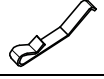

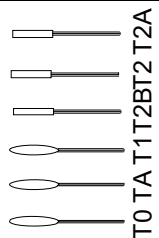
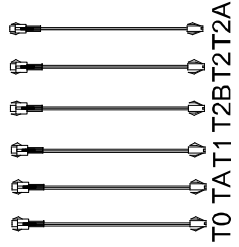


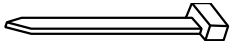
Priority	Definition	Displayed Content
1	Emergency stop	A01
2	R32 refrigerant leaks, requiring shutdown immediately	A11
3	Outdoor unit fault	A51
4	The AHU Kit slave unit fault	A74
5	Self-check fault	A81
6	MS (refrigerant flow direction switching device) fault	A82
7	Mode conflict	A91
8	1# EEV coil fault	b11
9	2# EEV coil fault	b13
10	Water level switch alarm	b36
11	Duplicate IDU address code	C11
12	Abnormal communication between the IDU and ODU	C21
13	Abnormal communication between the IDU and wired controller	C51
14	Abnormal communication between the IDU main control board and display board	C61
15	Abnormal communication between the AHU Kit slave unit and master unit	C71
16	Number of AHU Kits is not the same as the set number	C72
17	Abnormal communication between the main wired controller and secondary wired controller	C76
18	Abnormal communication between the IDU main control board and 1# Expansion board	C77
19	Abnormal communication between the IDU main control board and 2# Expansion board	C78
20	Abnormal communication between the IDU main control board and Switch module	C79
21	Air inlet temperature of the IDU is too low in heating mode	d16
22	Air inlet temperature of the IDU is too high in cooling mode	d17
23	T0 (fresh inlet air temperature sensor) short-circuits or cuts off	E21
24	T1 (IDU return air temperature sensor) short-circuits or cuts off	E24
25	TA (Outlet air temperature sensor) Short circuit or open circuit	E81
26	R32 refrigerant leakage sensor fault	EC1
27	T2A (heat exchanger liquid pipe temperature sensor) short-circuits or cuts off	F01
28	T2 (heat exchanger middle temperature sensor) short-circuits or cuts off	F11
29	T2B (heat exchanger gas pipe temperature sensor) short-circuits or cuts off	F21
30	Main control board EEPROM fault	P71
31	IDU display control board EEPROM fault	P72
32	Unit model code not set	U11
33	Capacity (HP) code not set	U12
34	The capacity value of the AHU Kit DIP switch does not match the model	U14
35	The DIP value of AHU Kit's fan speed output voltage is incorrect	U15
36	Address code not detected	U38

## 14.2 Spot Check

Display panel is checked with wired controller

No.	No. Parameter displayed on the wired controller during Kit check
1	IDU address (If there are multiple addresses, they are displayed one by one every 0.5s)
2	Capacity HP of IDU (When multiple units are connected in parallel, the total HP of master and slave units is displayed)
3	Set temperature value or set voltage value
4	Set temperature value or input capacity gear value executed by the program
5	T0 temperature (supply air temperature control) or T1 temperature (return air temperature)
6	T1 temperature after compensation (if not detected, it will be treated as an invalid value, and "99.9" will be displayed)
7	T2 temperature
8	T2A temperature
9	T2B temperature
10	TA temperature (displayed only in supply air temperature control mode; "---" is displayed in return air temperature control mode)
11	Set relative humidity ("65" is displayed by default)
12	Real-time relative humidity value detected (if no, "- -" is displayed)
13	- - -
14	Compressor discharge temperature
15	Target overheating
16	EEV opening degree (actual valve of 500P value: Displayed opening * 8; actual valve of 3000P value: Displayed opening * 48)
17	Main control software version No.
18	Display box software version No.
19	00
20	Historical error code (recent)
21	Historical error code (sub-recent)
22	Network address
23	Address of the connected expansion board
24	[— —] is displayed

## 15 Accessories

Name	Shape	Quantity	Function
Installation & Owner's Manual		1	-
Wired controller		1	Wired controller
Electronic Expansion valve extension cable		1	-
Fixed clamp of temperature sensor		3	-
Sleeve		3	-
Temperature sensors		6	-
Temperature sensors extension cables		6	-
Screw ST 3.9x25		4	Secure the installation board
Plastic expanded tube		4	-
Cable Tie		6	-

## 16 Appendix

### 16.1 Temperature Sensor Resistance Characteristics

Temperature (°C)	Resistance (kΩ)	Temperature (°C)	Resistance (kΩ)	Temperature (°C)	Resistance (kΩ)	Temperature (°C)	Resistance (kΩ)
-20	106.193	20	12.621	60	2.355	100	0.620
-19	100.028	21	12.041	61	2.269	101	0.602
-18	94.259	22	11.490	62	2.187	102	0.584
-17	88.857	23	10.967	63	2.109	103	0.567
-16	83.796	24	10.471	64	2.033	104	0.551
-15	79.054	25	10.000	65	1.961	105	0.535
-14	74.607	26	9.553	66	1.892	106	0.520
-13	70.436	27	9.128	67	1.825	107	0.505
-12	66.521	28	8.725	68	1.761	108	0.490
-11	62.847	29	8.342	69	1.700	109	0.477
-10	59.396	30	7.977	70	1.641	110	0.463
-9	56.153	31	7.631	71	1.585	111	0.450
-8	53.106	32	7.302	72	1.530	112	0.438
-7	50.241	33	6.988	73	1.478	113	0.425
-6	47.546	34	6.690	74	1.428	114	0.414
-5	45.010	35	6.407	75	1.380	115	0.402
-4	42.623	36	6.137	76	1.334	116	0.391
-3	40.376	37	5.880	77	1.289	117	0.381
-2	38.259	38	5.635	78	1.247	118	0.370
-1	36.264	39	5.402	79	1.206	119	0.361
0	34.385	40	5.179	80	1.166	120	0.351
1	32.613	41	4.968	81	1.128	121	0.342
2	30.941	42	4.766	82	1.091	122	0.332
3	29.364	43	4.573	83	1.056	123	0.324
4	27.876	44	4.390	84	1.022	124	0.315
5	26.471	45	4.215	85	0.990	125	0.307
6	25.145	46	4.047	86	0.958	126	0.299
7	23.892	47	3.888	87	0.928	127	0.291
8	22.708	48	3.736	88	0.899	128	0.284
9	21.590	49	3.590	89	0.870	129	0.277
10	20.532	50	3.451	90	0.843	130	0.269
11	19.532	51	3.318	91	0.817	131	0.263
12	18.586	52	3.192	92	0.792	132	0.256
13	17.690	53	3.070	93	0.768	133	0.250
14	16.843	54	2.954	94	0.744	134	0.243
15	16.041	55	2.843	95	0.722	135	0.237
16	15.281	56	2.737	96	0.700	136	0.231
17	14.562	57	2.635	97	0.679	137	0.226
18	13.880	58	2.538	98	0.659	138	0.220
19	13.234	59	2.444	99	0.639	139	0.215







## NOTE CONCERNING PROTECTION OF ENVIRONMENT



This product must not be disposed of via normal household waste after its service life, but must be taken to a collection station for the recycling of electrical and electronic devices. The symbol on the product, the operating instructions or the packaging indicate such disposal procedures. The materials are recyclable in accordance with their respective symbols. By means of re-use, material recycling or any other form of recycling old appliances you are making an important contribution to the protection of our environment. Please ask your local council where your nearest disposal station is located.

## INFORMATION CONCERNING USED REFRIGERANT MEDIUM

This unit is containing fluorinated gases included in the Kyoto protocol.  
The maintenance and the liquidation must be carried out by qualified personnel.

Type of refrigerant: R32/R410a

The composition of the cooling medium R32: (100% HFC-32)

The composition of the cooling medium R410a: (50% HFC-32, 50% HFC-125)

The quantity of the refrigerant: Please see the unit label.

The value GWP of R32: 675 (1 kg R32 = 0,675 t CO<sub>2</sub> eq)

The value GWP of R410a: 2088 (1kg R410a=2,088t CO<sub>2</sub> eq)

GWP = Global Warming Potential

**NOTE:** Indoor unit can use R32 and R410a, it depends on outdoor unit.



Appliance filled with flammable gas R32.

In case of quality problem or other please contact your local supplier or authorized service center.

**Emergency number: 112**

## PRODUCER

SINCLAIR CORPORATION Ltd.  
16 Great Queen Street  
WC2B 5AH London  
United Kingdom  
[www.sinclair-world.com](http://www.sinclair-world.com)

This product was manufactured in China (Made in China).

## REPRESENTATIVE

SINCLAIR Global Group s.r.o.  
Purkynova 45  
612 00 Brno  
Czech Republic

## TECHNICAL SUPPORT

SINCLAIR Global Group s.r.o.  
Purkynova 45  
612 00 Brno  
Czech Republic  
Tel.: +420 800 100 285 | Fax: +420 541 590 124  
[www.sinclair-solutions.com](http://www.sinclair-solutions.com) | [info@sinclair-solutions.com](mailto:info@sinclair-solutions.com)

