

FULL DC INVERTER SYSTEMS

SERVICE MANUAL

SAHK-xx

SINCLAIR AIR HANDLING KIT



Original instructions

IMPORTANT NOTE:

Read this manual carefully before installing or operating your new air conditioning unit. Make sure to save this manual for future reference.

CONTENTS

- 1 Introduction 4
- 2 System Layout 5
- 3 VRF-AHU System Schematic 6
- 4 Product Lineup 6
- 5 Nomenclature 7
- 6 Typical Applications 7
- 7 Main PCB Ports 9
- 8 Dip Switch Definitions 12
- 9 Piping Diagrams 16
- 10 Wiring Diagram 17
- 11 Troubleshooting 18
- 12 Accessories..... 63
- 13 Appendix..... 64

1 Introduction

The AHU Kit can be connected to the heat pump/heat recovery/cooling only ODU and the third party AHU. Every third party AHU can be connected to one AHU Kit or to several AHU Kites in a parallel connection (up to four). This manual describes how to install and operate an AHU Kit.

Using an AHU Kit, a unit can be controlled by either return air temperature or by outlet air temperature.

- When return air temperature control is selected, the connected AHU can be considered to be a standard IDU.
- Users can opt to use the factory controller or a third party controller.
- The AHU Kit has an input port of 0-10V. A third party controller is required to provide 0-10V of input. The system capacity requirement or temperature can be set based on 0-10V input.
- **Appearance of the AHU Kit:**

No	Parts
1	Box cover
2	Main control board
3	Main control board support seat
4	Electronic expansion valve assembly
5	Box body

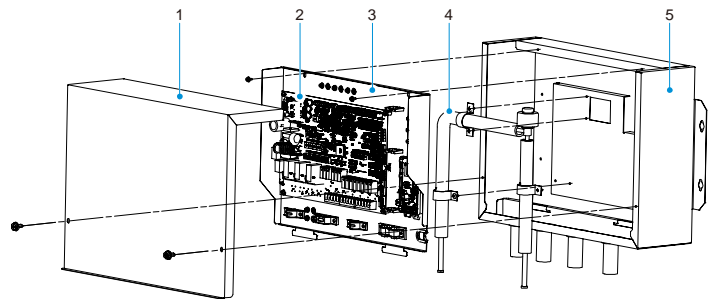

2 System Layout

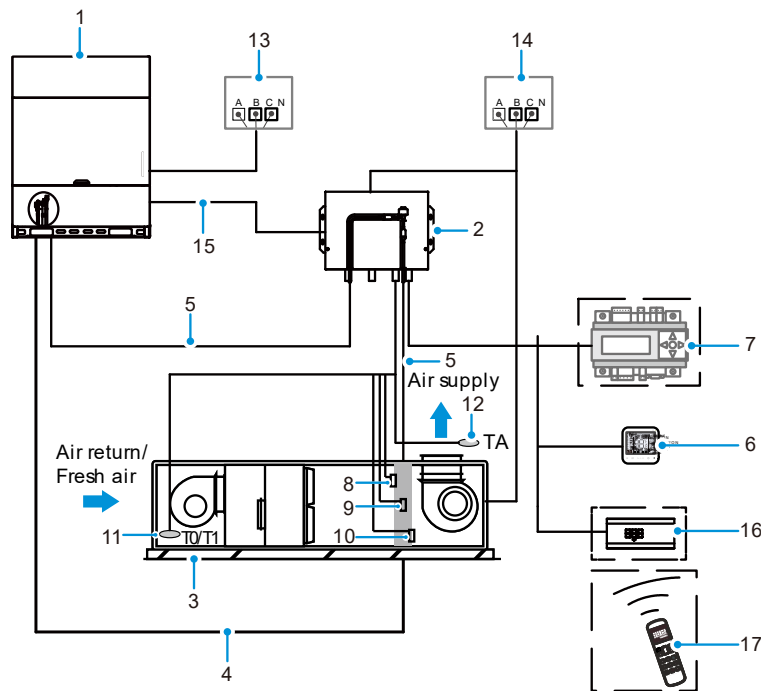

No.	Name	Description
1	ODU	Supports heat pump type and heat recovery type VRF ODUs
2	Kit	Reserve brazing joint for the refrigerant inlet/outlet pipe
3	Third-party AHU	Only air-cooled direct expansion AHU is supported
4	Connecting piping between ODU and AHU	For piping diameters, see Pipe Layout in the related ODU Installation Manual
5	Connecting piping between ODU and the kit, connecting piping between AHU and the kit	Installation Manual
6	Wired controller	Factory default
7	Third-party controller	DDC controller
8	T2A-AHU heat exchanger liquid pipe temperature sensor	Factory default
9	T2-AHU heat exchanger middle temperature sensor	Factory default
10	T2B-AHU heat exchanger gas pipe temperature sensor	Factory default
11	T1-AHU indoor return air temperature sensor	Factory default
11	T0-AHU outdoor fresh air temperature sensor	Factory default
12	TA-AHU outlet air temperature sensor	Factory default
13	ODU power supply	For power supply specifications, see Power Supply Selection
14	AHU and kit power supply	The power supply is separated from the outdoor unit connection
15	Communication wires between the kit and ODU	For the materials and specifications of communication wires, see Electrical Installation-Connection of Signal Cables in Installation Manual
16	Display box	Optional, can be purchased separately from the factory
17	Remote controller	Optional, can be purchased separately from the factory

3 VRF-AHU System Schematic

Figure 1-1.1: System schematic

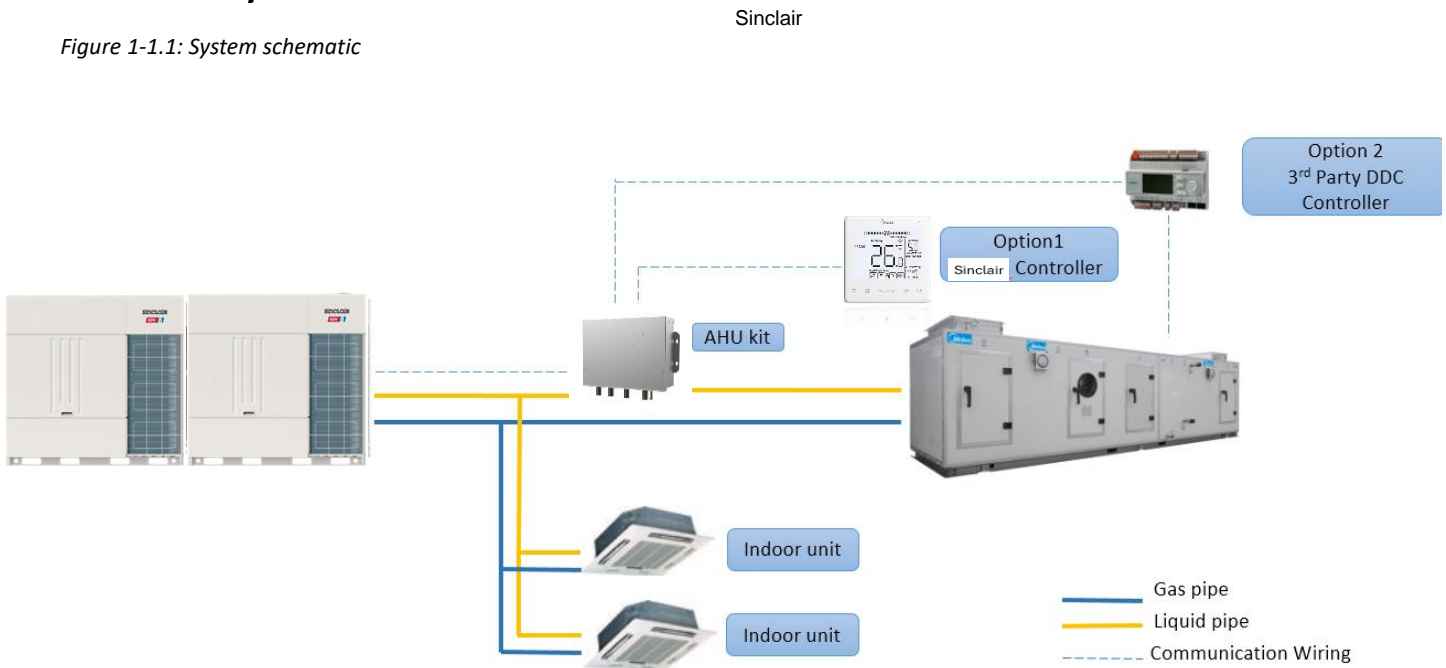

The system is composed by largely indoor and outdoor parts. Outdoor part is Sinclair VRF outdoor unit. Indoor part concludes other brand direct expansion type AHU (Local supply) and Sinclair AHU VRF AHU Kit. AHU Kit forms the connection between Sinclair VRF outdoor unit and other brand or Sinclair brand direct expansion type AHU.

1. Outdoor: Sinclair VRF outdoor unit
SDV6, SDV5,
2. Indoor: Direct expansion type AHU (Local supply or Sinclair Brand)
Direct Expansion type AHU supplied by local market or by Sinclair end
3. DX AHU Kit
PCBs, EEV Temperature sensors (T0 fresh inlet air temperature sensor, T1 return air temperature sensor, TA outlet air temperature sensor, T2A heat exchanger liquid pipe temperature sensor, T2 heat exchanger middle temperature sensor, T2B heat exchanger gas pipe temperature sensor) and wired controller.
4. DDC (Direct Digital Control) controller
DDC controller is optional. It's supplied by the third party such as SIEMENS. Through DDC, some functions such as temperature setting control and capacity setting control can be realized.

4 Product Lineup



5 Nomenclature

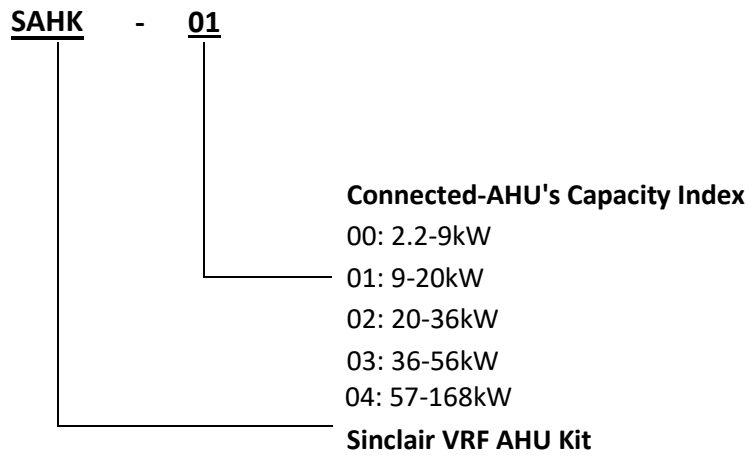

6 Typical Applications

6.1 Single VRF AHU Kit connect to one AHU

When the type AHU's capacity is less than 224kW, single VRF-AHU Kit connects to one AHU method is suggested.

Figure 6-1.1: Single VRF AHU Kit connect to one AHU

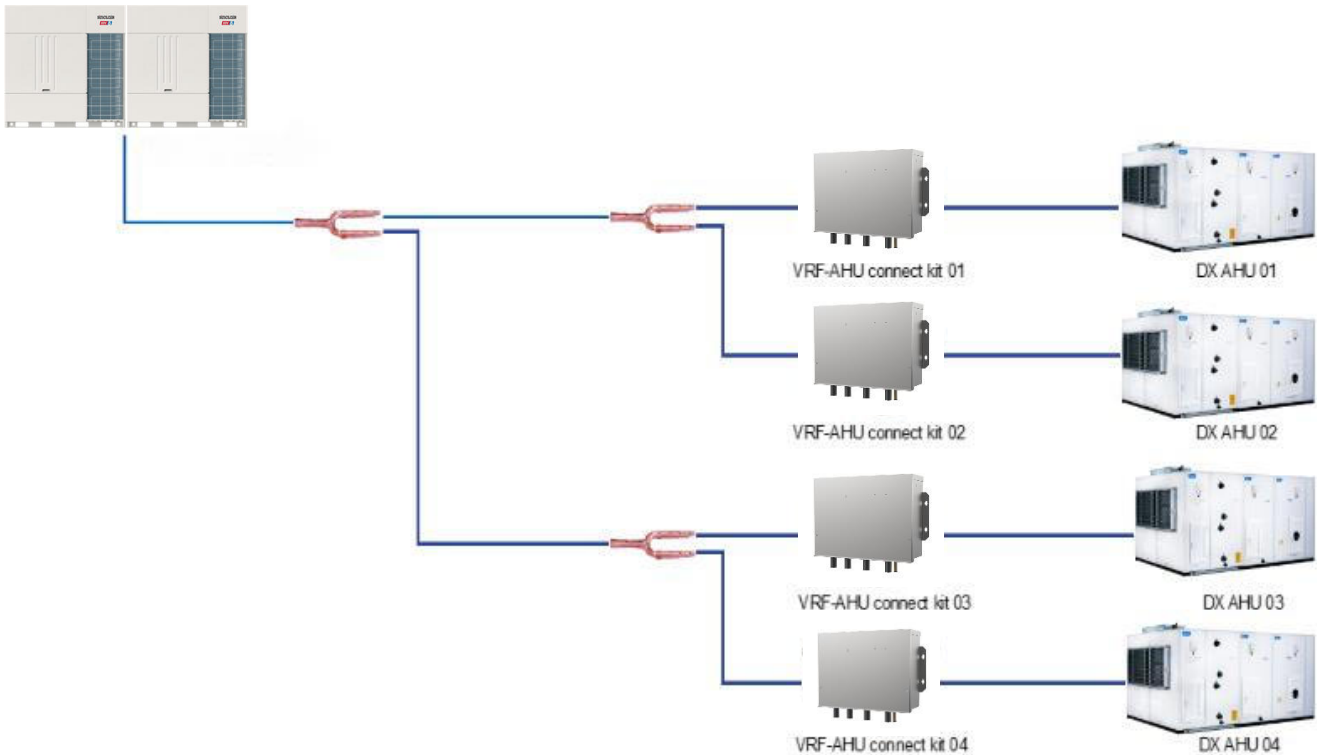

Notes: The example is just for application illustration. Only the liquid pipe connection is shown.

6.2 Multiple VRF AHU Kites connect with one AHU

Multiple kits are connected in parallel, and each kit corresponds to a heat exchanger of the AHU. A maximum of four kits can be connected in parallel. The system connection is shown in the figure below:

Figure 5-1.2: Multiple VRF AHU Kites connect to one AHU

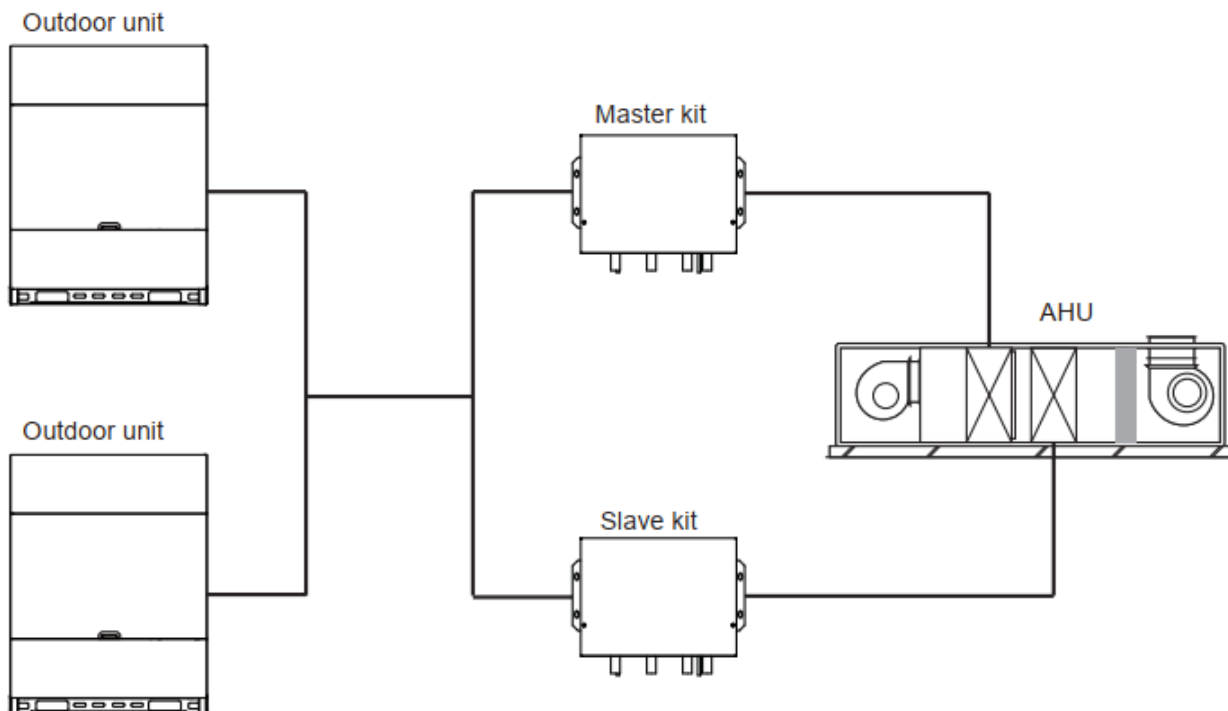

Notes: The example is just for application illustration. Only the liquid pipe connection is shown

6.3 AHU and VRF IDU Combination

DX type AHU and VRF indoor units can be combined in the same refrigerant system.

Figure 5-1.3: AHU and VRF IDU combination application

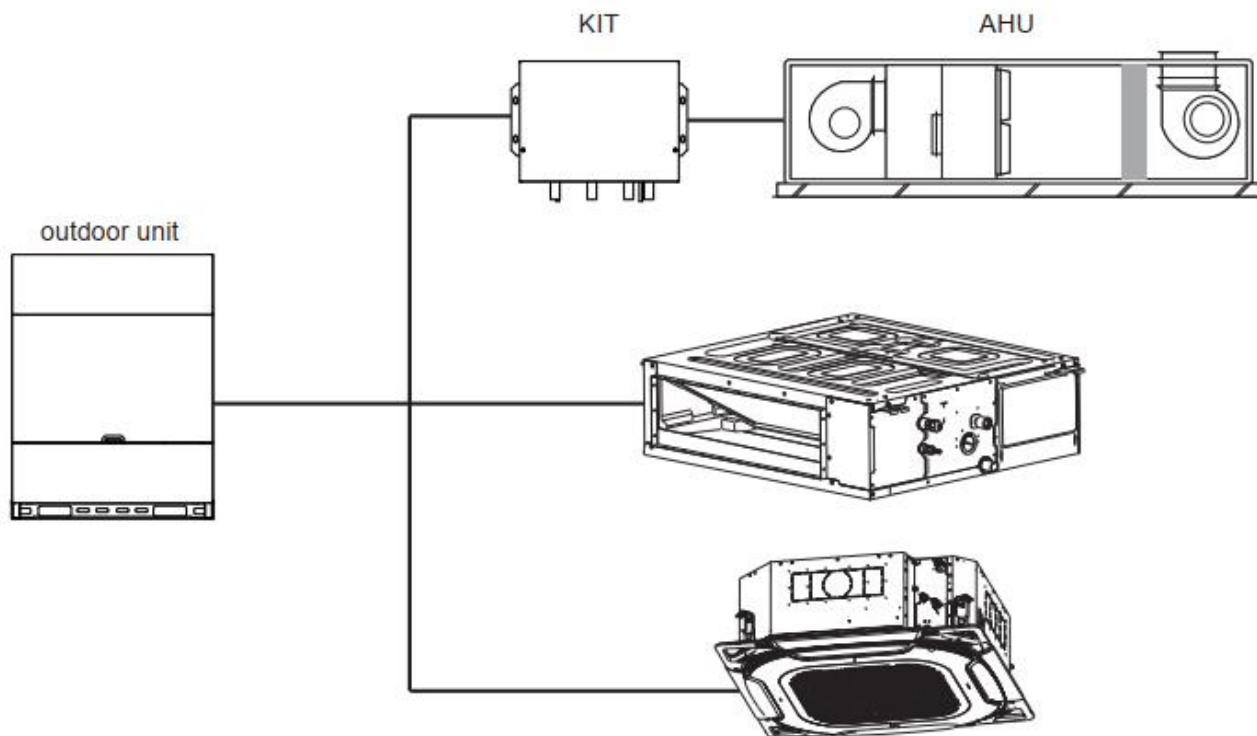

Notes: The example is just for application illustration. Only the liquid pipe connection is shown

7 Main PCB Ports

Figure 7-1.1: SAHK-(00, 01, 02, 03, 04) Main PCB Ports

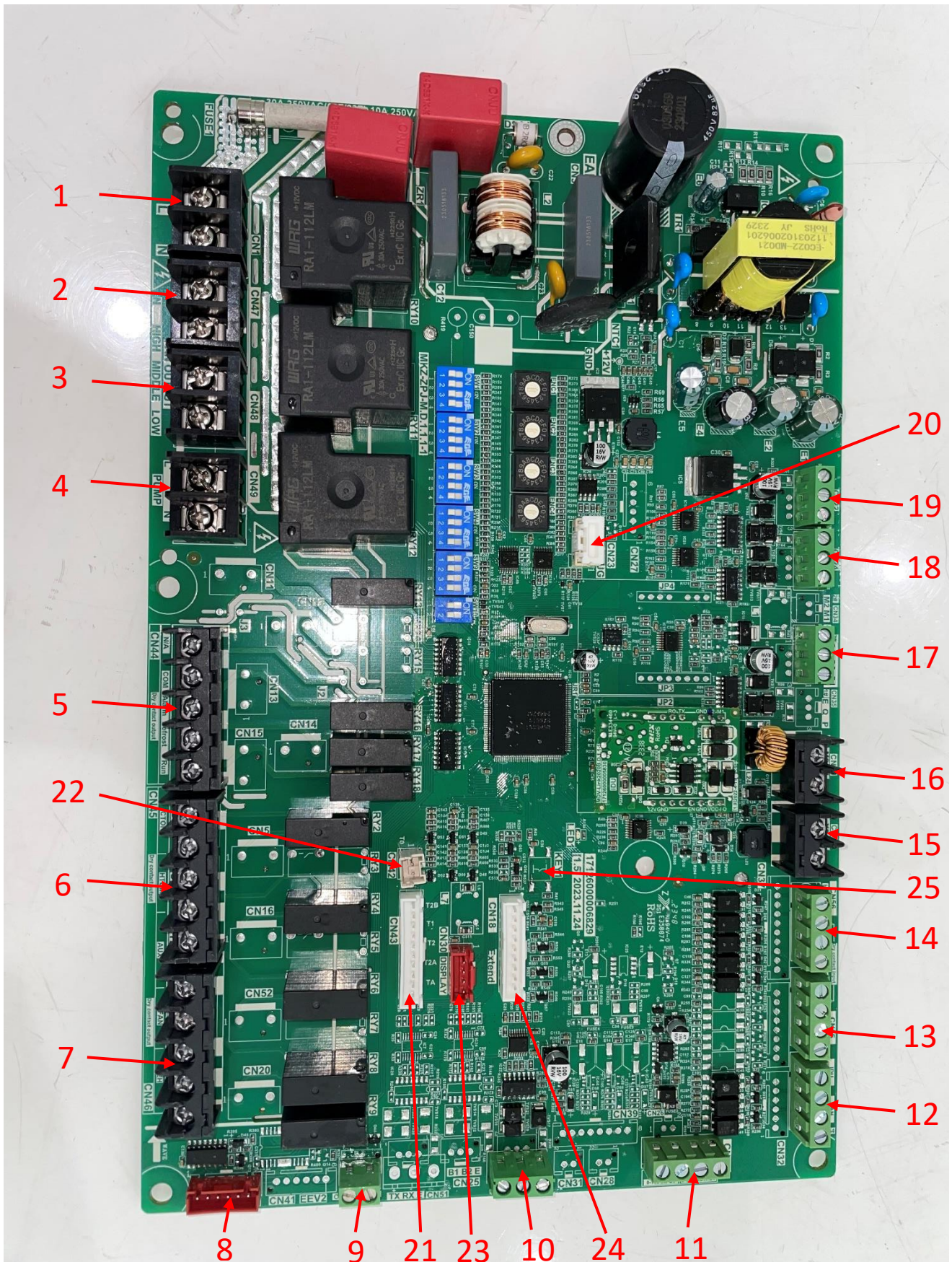

Label in Figure 7-1.1	Port code		Content	Port voltage
1	CN1	L N	PCB power supply input	220 V~ AC
2	CN47-2	HIGH	Fan speed power input-HIGH	220 V~ AC
3	CN48-1	MIDDLE	Fan speed power input-MIDDLE	220 V~ AC
	CN48-2	LOW	Fan speed power input-LOW	220 V~ AC
4	CN49	PUMP	Pump running signal output	220 V~ AC
5	CN44-3 (CN44-2 is the common point)	Alarm	ALARM output	0-24V AC/DC
	CN44-4 (CN44-2 is the common point)	Defrost	Defrosting status output	0-24V AC/DC
	CN44-5 (CN44-2 is the common point)	Run	Running status output	0-24V AC/DC
6	CN45-1, CN45-2	CTON	Feedback output in Cool mode	0-24V AC/DC
	CN45-3, CN45-4	HTOM	Feedback output in Heat mode	0-24V AC/DC
	CN45-5, CN46-1	AUX	Third-party heat source dry contact output (reserved)	0-24V AC/DC
7	CN46-2, CN46-3	FAN	Interlocked air valve signal output	0-24V AC/DC
	CN46-4, CN46-5	DEH	Third-party dehumidifier output	0-24V AC/DC
8	CN40	EEV1	1# Electronic expansion valve	0V or 12V DC
9	CN50	WATER	Water level switch	0V or 3.3V DC
10	CN29	A1 A2 E	Connect to the ModBus protocol wired controller	5V DC
11	CN53-1 (positive), CN53-2 (negative)	0-10V output	0-10V output	0-10V DC
	CN53-3 (positive), CN53-4 (negative)	0-10V input	0-10V input	0-10V DC
12	CN54-1, CN54-2 (GND)	Indoor unit (ON/OFF)	Remote ON/OFF input	0V or 12V DC
	CN54-3, CN54-4 (GND)	FAN (ON/OFF)	Fan ON/OFF input	0V or 12V DC
13	CN55-1 (CN55-4 is the common point)	LOW	Fan speed input-LOW	0V or 12V DC
	CN55-2 (CN55-4 is the common point)	MIDDLE	Fan speed input-MIDDLE	0V or 12V DC
	CN55-3 (CN55-4 is the common point)	HIGH	Fan speed input-HIGH	0V or 12V DC
14	CN56-1 (CN56-4 is the common point)	HEAT	Mode input-HEAT	0V or 12V DC
	CN56-2 (CN56-4 is the common point)	COOL	Mode input-COOL	0V or 12V DC
	CN56-3 (CN56-4 is the common point)	FAN	Mode input-FAN (reserved)	0V or 12V DC
15	CN38	X1 X2	Connect to the carrier wired controller interfaces X1X2	18V DC
16	CN36	M1 M2	Connect to the ODU MDV-link communication interfaces M1M2	24V DC

Label in Figure 7-1.1	Port code	Content	Port voltage	Label in Figure 7-1.1
17	CN21	P Q E	Connect to the ODU communication interface P/Q/E	2.5-2.7V DC
18	CN24	C1 C2 E	Master-slave independent Kit communication interface	2.5-2.7V DC
19	CN22	D1(X) D2(Y) E	Connect to the main wired controller supplied by factory	2.5-2.7V DC
21	CN43-10, CN43-9 (power supply)	TA	TA Temperature sensor	0-3.3V DC (varying)
	CN43-2, CN43-1 (power supply)	T2B	T2B Temperature sensor	0-3.3V DC (varying)
	CN43-4, CN43-3 (power supply)	T1	T1 Temperature sensor	0-3.3V DC (varying)
	CN43-6, CN43-5 (power supply)	T2	T2 Temperature sensor	0-3.3V DC (varying)
	CN43-8, CN43-7 (power supply)	T2A	T2A Temperature sensor T2A	0-3.3V DC (varying)
22	CN42 (CN42-1: power supply)	T0	T0 Temperature sensor	0-3.3V DC (varying)
23	CN30	DISPLAY	Display board interface (reserved)	12V DC
24	CN18	Extend	Port to connect the communication switch module (reserved)	12V DC
25	Key1	KEY1	Spot check button	0-3.3V DC

Full return air AHU and Mixed air AHU







Port code	Temperature sensor
CN7-T1	Return air temperature sensor T1
CN7-T2A	Evaporator inlet temperature sensor T2A
CN7-T2	Evaporator intermediate temperature sensor T2
CN7-T2B	Evaporator outlet sensor T2B

Full fresh air pretreatment AHU (Heat pump system)

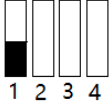
Port code	Temperature sensor
CN7-T1	Inlet air temperature sensor T1
CN7-T2A	Evaporator inlet temperature sensor T2A
CN7-T2	Evaporator intermediate temperature sensor T2
CN7-T2B	Evaporator outlet sensor T2B
CN7-TA	Outlet air temperature sensor TA

8 Dip Switch Definitions





1) Definitions of each bit of SW1:

<p style="text-align: center;">ON</p>  <p style="text-align: center;">Valid for the master unit only</p>	<ul style="list-style-type: none"> • SW1-1 is 0: shutdown compensation temperature (cooling) is 0°C (factory default) • SW1-1 is 1: shutdown compensation temperature (cooling) is 2°C (outlet air temperature control is invalid)
<p style="text-align: center;">ON</p>  <p style="text-align: center;">Valid for the master unit only</p>	<ul style="list-style-type: none"> • SW1-2 is 0: AHU Kit provides three fan speeds (factory default) • SW1-2 is 1: only high fan speed (the specific speed is determined by the ENC2 dip switch).
<p style="text-align: center;">ON</p>  <p style="text-align: center;">Valid for the master unit only</p>	<ul style="list-style-type: none"> • SW1-3 and SW1-4 are 00: the number of slave AHU Kites connected in parallel is 0 (factory default); valid for the master unit
<p style="text-align: center;">ON</p>  <p style="text-align: center;">Valid for the master unit only</p>	<ul style="list-style-type: none"> • SW1-3 and SW1-4 are 01: the number of slave AHU Kites connected in parallel is 1
<p style="text-align: center;">ON</p>  <p style="text-align: center;">Valid for the master unit only</p>	<ul style="list-style-type: none"> • SW1-3 and SW1-4 are 10: the number of slave AHU Kites connected in parallel is 2
<p style="text-align: center;">ON</p>  <p style="text-align: center;">Valid for the master unit only</p>	<ul style="list-style-type: none"> • SW1-3 and SW1-4 are 11: the number of slave AHU Kites connected in parallel is 3



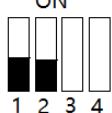

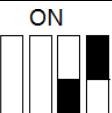
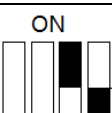
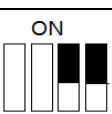

2) Definitions of each bit of SW2:

<p>ON</p> <p>1 2 3 4</p>	<ul style="list-style-type: none"> SW2-1 is reserved
<p>ON</p> <p>1 2 3 4</p>	<ul style="list-style-type: none"> SW2-2 is 0 and SW4-3, SW4-4 is 00: Energy demand/fan speed/mode all adopt Sinclair controller mode. <p>SW2-2 is 0 and SW4-3, SW4-4 is 01:</p> <ul style="list-style-type: none"> Energy demand: input energy demand gear value 0-10V through third-party controller. Fan speed: input fan speed dry contact signal mode through third-party controller. Mode: Input mode dry contact signal through third-party controller <p>SW2-2 is 0 and SW4-3, SW4-4 is 10:</p> <ul style="list-style-type: none"> Energy demand: input set temperature value 0-10V through third-party controller. Fan speed: input fan speed dry contact signal mode through third-party controller. Mode: Input mode dry contact signal through third-party controller <p>SW2-2 is 1 (reserved)</p> <ul style="list-style-type: none"> Energy demand: Set temperature value or energy demand gear value through 0-10V input of third-party controller. Fan speed: input 0-10V fan speed through third-party controller. Mode: Input mode dry contact signal through third-party controller
<p>ON</p> <p>1 2 3 4</p>	<ul style="list-style-type: none"> SW2-3 and SW2-4 are 00: master AHU Kit
<p>ON</p> <p>1 2 3 4</p>	<ul style="list-style-type: none"> SW2-3 and SW2-4 are 01: slave AHU Kit 1
<p>ON</p> <p>1 2 3 4</p>	<ul style="list-style-type: none"> SW2-3 and SW2-4 are 10: slave AHU Kit 2
<p>ON</p> <p>1 2 3 4</p>	<ul style="list-style-type: none"> SW2-3 and SW2-4 are 11: slave AHU Kit 3

3) Definitions of each bit of SW3:

	Return Air Temperature Control (SW4-1: 0)	Outlet Air Temperature Control (SW4-1: 1)
<p>ON</p>  <p>Valid for the master unit only</p>	<ul style="list-style-type: none"> SW3-1 and SW3-2 are 00: anti-cold air temperature value in heating mode, with fan closing temperature of 15 °C and fan opening temperature of 28 °C. (Factory default) 	<ul style="list-style-type: none"> SW3-1 and SW3-2 are 00: anti-cold air temperature value in heating mode, with fan closing temperature of 5°C and fan opening temperature of 10 °C. (Factory default)
<p>ON</p>  <p>Valid for the master unit only</p>	<ul style="list-style-type: none"> SW3-1 and SW3-2 are 01: anti-cold air temperature value in heating mode, with fan closing temperature of 10 °C and fan opening temperature of 18 °C. (Factory default) 	<ul style="list-style-type: none"> SW3-1 and SW3-2 are 01: anti-cold air temperature value in heating mode, with fan closing temperature of 5 °C and fan opening temperature of 12 °C. (Factory default)
<p>ON</p>  <p>Valid for the master unit only</p>	<ul style="list-style-type: none"> SW3-1 and SW3-2 are 10: anti-cold air temperature value in heating mode, with fan closing temperature of 24 °C and fan opening temperature of 28 °C. (Factory default) 	<ul style="list-style-type: none"> SW3-1 and SW3-2 are 10: anti-cold air temperature value in heating mode, with fan closing temperature of 5 °C and fan opening temperature of 14 °C. (Factory default)
<p>ON</p>  <p>Valid for the master unit only</p>	<ul style="list-style-type: none"> SW3-1 and SW3-2 are 11: anti-cold air temperature value in heating mode is invalid 	<ul style="list-style-type: none"> SW3-1 and SW3-2 are 11: anti-cold air temperature value in heating mode is invalid
<p>ON</p>  <p>Valid for the master unit only</p>	<ul style="list-style-type: none"> SW3-3 and SW3-4 are 00: temperature compensation in heating mode is 6°C (factory default) 	<ul style="list-style-type: none"> SW3-3 and SW3-4 are 00: Outlet air temperature control is invalid
<p>ON</p>  <p>Valid for the master unit only</p>	<ul style="list-style-type: none"> SW3-3 and SW3-4 are 01: temperature compensation in heating mode is 2°C. (By Sinclair Controller) 	<ul style="list-style-type: none"> SW3-3 and SW3-4 are 01: Outlet air temperature control is invalid. (By Sinclair Controller)
<p>ON</p>  <p>Valid for the master unit only</p>	<ul style="list-style-type: none"> SW3-3 and SW3-4 are 10: temperature compensation in heating mode is 4°C 	<ul style="list-style-type: none"> SW3-3 and SW3-4 are 10: Outlet air temperature control is invalid
<p>ON</p>  <p>Valid for the master unit only</p>	<ul style="list-style-type: none"> SW3-3 and SW3-4 are 11: temperature compensation in heating mode is 0°C (Follow Me function) 	<ul style="list-style-type: none"> SW3-3 and SW3-4 are 11: No temperature compensation for outlet air temperature control by default

4) Definitions of each bit of SW4:

 <p>Valid for the master unit only</p>	<ul style="list-style-type: none"> • SW4-1 is 0: return air temperature control (factory default) • SW4-1 is 1: outlet air temperature control
	<ul style="list-style-type: none"> • SW4-2 indicates high bit (ON indicates + 16)
 <p>Valid for the master unit only</p>	<ul style="list-style-type: none"> • SW4-3 and SW4-4 are 00: factory controller mode (factory default)
 <p>Valid for the master unit only</p>	<ul style="list-style-type: none"> • SW4-3 and SW4-4 are 01: capacity output mode of a third party controller
 <p>Valid for the master unit only</p>	<ul style="list-style-type: none"> • SW4-3 and SW4-4 are 10: set temperature control mode of a third party controller
 <p>Valid for the master unit only</p>	<ul style="list-style-type: none"> • SW4-3 and SW4-4 are 11: set temperature control mode of a third party controller (reserved)

9 Piping Diagrams

SAHK-00 / SAHK-01/ SAHK-02 / SAHK-03 / SAHK-04

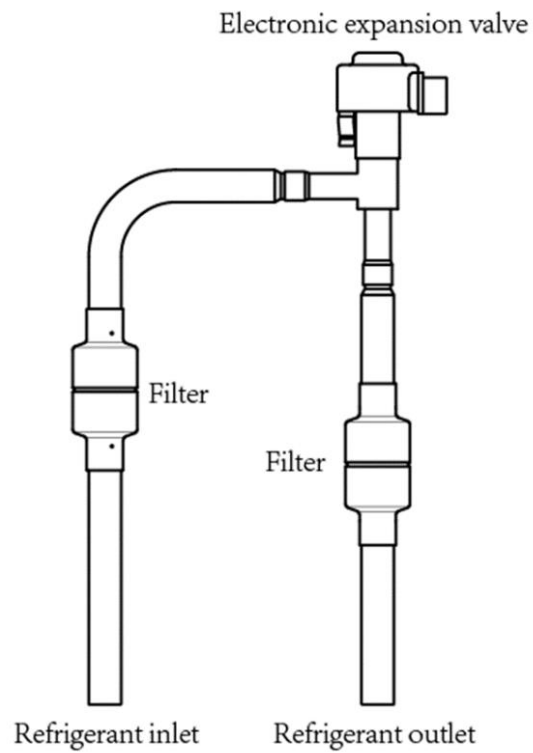

Key components:

1. **Electronic Expansion Valve (EXV):**
Controls refrigerant flow and reduces refrigerant pressure.
2. **Filter:**
Protects the EXV. Prevents the rust and dust going into the EXV.

10 Wiring Diagram

SAHK-00 / SAHK-01 / SAHK-02 / SAHK-03 / SAHK-04

Figure 12-10.1 SAHK-(00, 01, 02, 03, 04) wiring diagram

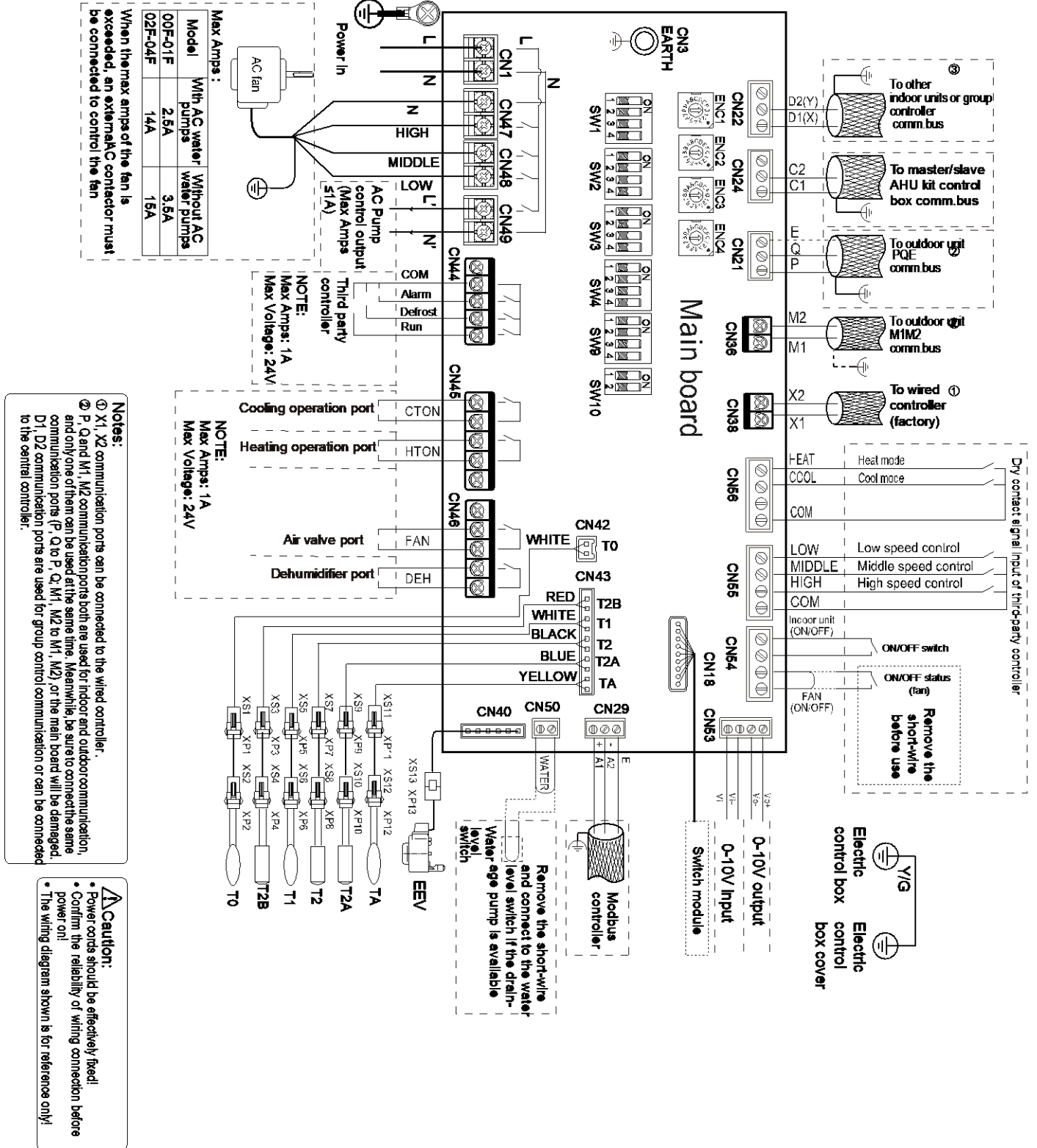

11 Troubleshooting

11.1 Error Code

Priority	Definition	Displayed Content
1	Emergency stop	A01
2	R32 refrigerant leaks, requiring shutdown immediately	A11
3	Outdoor unit fault	A51
4	The AHU Kit slave unit fault	A74
5	Self-check fault	A81
6	MS (refrigerant flow direction switching device) fault	A82
7	Mode conflict	A91
8	1# EEV coil fault	b11
9	2# EEV coil fault	b13
10	Water level switch alarm	b36
11	Duplicate IDU address code	C11
12	Abnormal communication between the IDU and ODU	C21
13	Abnormal communication between the IDU and wired controller	C51
14	Abnormal communication between the IDU main control board and display board	C61
15	Abnormal communication between the AHU Kit slave unit and master unit	C71
16	Number of AHU Kits is not the same as the set number	C72
17	Abnormal communication between the main wired controller and secondary wired controller	C76
18	Abnormal communication between the IDU main control board and 1# Expansion board	C77
19	Abnormal communication between the IDU main control board and 2# Expansion board	C78
20	Abnormal communication between the IDU main control board and Switch module	C79
21	Air inlet temperature of the IDU is too low in heating mode	d16
22	Air inlet temperature of the IDU is too high in cooling mode	d17
23	T0 (fresh inlet air temperature sensor) short-circuits or cuts off	E21
24	T1 (IDU return air temperature sensor) short-circuits or cuts off	E24
25	TA (Outlet air temperature sensor) Short circuit or open circuit	E81
26	R32 refrigerant leakage sensor fault	EC1
27	T2A (heat exchanger liquid pipe temperature sensor) short-circuits or cuts off	F01
28	T2 (heat exchanger middle temperature sensor) short-circuits or cuts off	F11
29	T2B (heat exchanger gas pipe temperature sensor) short-circuits or cuts off	F21
30	Main control board EEPROM fault	P71
31	IDU display control board EEPROM fault	P72
32	Unit model code not set	U11
33	Capacity (HP) code not set	U12
34	The capacity value of the AHU Kit DIP switch does not match the model	U14
35	The DIP value of AHU Kit's fan speed output voltage is incorrect	U15
36	Address code not detected	U38

11.2 Spot Check

Display panel is checked with wired controller

No.	No. Parameter displayed on the wired controller during Kit check
1	IDU address (If there are multiple addresses, they are displayed one by one every 0.5s)
2	Capacity HP of IDU (When multiple units are connected in parallel, the total HP of master and slave units is displayed)
3	Set temperature value or set voltage value
4	Set temperature value or input capacity gear value executed by the program
5	T0 temperature (supply air temperature control) or T1 temperature (return air temperature)
6	T1 temperature after compensation (if not detected, it will be treated as an invalid value, and "99.9" will be displayed)
7	T2 temperature
8	T2A temperature
9	T2B temperature
10	TA temperature (displayed only in supply air temperature control mode; "---" is displayed in return air temperature control mode)
11	Set relative humidity ("65" is displayed by default)
12	Real-time relative humidity value detected (if no, "- -" is displayed)
13	- - -
14	Compressor discharge temperature
15	Target overheating
16	EEV opening degree (actual valve of 500P value: Displayed opening * 8; actual valve of 3000P value: Displayed opening * 48)
17	Main control software version No.
18	Display box software version No.
19	00
20	Historical error code (recent)
21	Historical error code (sub-recent)
22	Network address
23	Address of the connected expansion board
24	[— — —] is displayed

11.3 General

- Sections 11.2 and 11.3 describe some initial troubleshooting steps that can be taken when an error occurs. If these steps do not resolve the issue, arrange for a professional technician to investigate the problem. Do not attempt further investigations or troubleshooting yourself.
- If any of the following errors occur, power the unit off, contact a professional technician immediately and do not attempt troubleshooting yourself:
 - A safety device such as a fuse or circuit breaker frequently blows/trips.
 - An object or water enters the unit.
 - Water is leaking from the unit.

Caution Notes

Caution

- Do not attempt to inspect or repair the unit by yourself. Arrange for a qualified technician to carry out all servicing and maintenance

11.4 A01 – Emergency shutdown

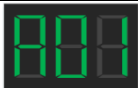
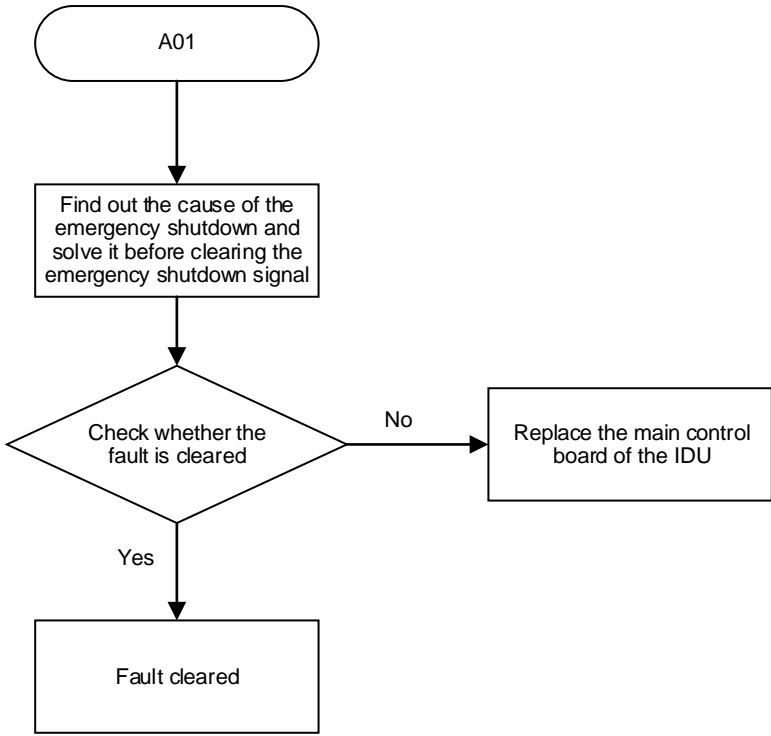
Error display	Digital display	Display position
		Panel, display box, and wired controller
Error impact	The faulty IDU and other IDUs of the same system: stop running, displaying code "A01" (V6 platform indoor unit displays "A0" code)	
	ODU of the same system: stop running, displaying code "A01" (V6 platform outdoor unit displays "A0" code)	
Error trigger	When the IDU receives an emergency shutdown signal from the ODU	
Error recovery	After troubleshooting, power on again	
Possible cause	<ul style="list-style-type: none"> ■ An emergency shutdown signal is received. ■ The IDU main control board is damaged. 	
Troubleshooting	 <pre> graph TD A01([A01]) --> B[Find out the cause of the emergency shutdown and solve it before clearing the emergency shutdown signal] B --> C{Check whether the fault is cleared} C -- No --> D[Replace the main control board of the IDU] C -- Yes --> E[Fault cleared] </pre>	
	<p>Note:</p> <p>1. Emergency shutdown is usually caused by the outdoor unit receiving an emergency shutdown command sent by the central controller or external reasons. For detailed handling instructions, please refer to the corresponding outdoor unit troubleshooting manual.</p>	

11.5 A11 - R32 refrigerant leaks, requiring shutdown immediately

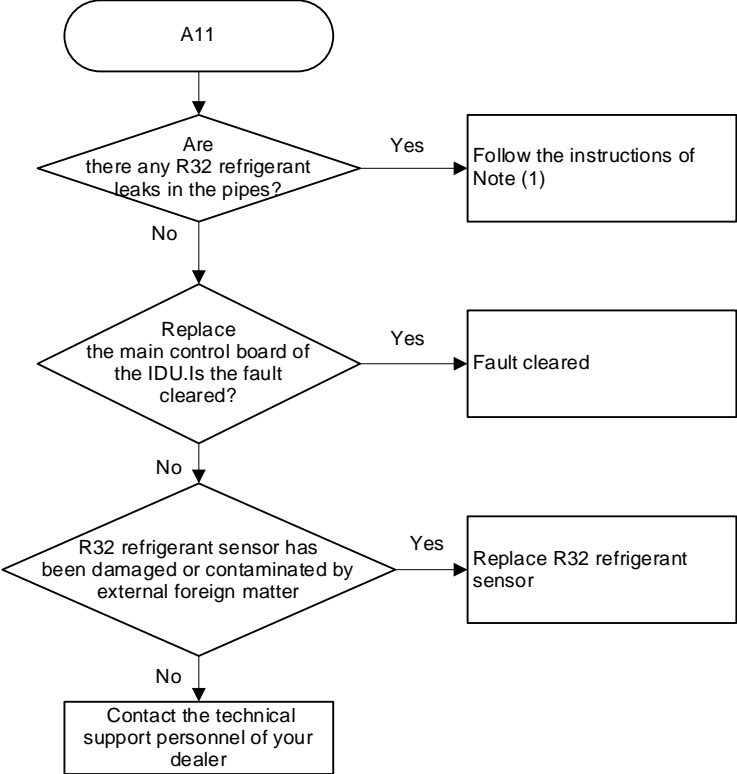
Error display	Digital display	Display position
		Panel, display box, and wired controller
Error impact	<ul style="list-style-type: none"> ■ Faulty IDU: The fan operates at the highest speed, the EEV is closed (Note: Fault persists after power on again), and buzzer of the display control board of the faulty IDU and buzzer of wired controller connected to the faulty IDU keep beeping. ■ Other IDUs of the same system: Refrigerant is recycled to ODU. After recycling is completed, other IDUs stop running, displaying code "A51" - ODU fault ODU of the same system: It stops running after recycling is completed, displaying code "A11" - IDU refrigerant leaks.	
Error trigger	When the IDU main control board receives a refrigerant leakage signal from R32 refrigerant detection device (See Figure 1 below) or the abnormal communication among the IDU main control board, the adapter board and the control board of the R32 refrigerant detection device causes the fault to trigger by mistake.	
Error recovery	Has not detected the refrigerant leak signal and has received the signal of refrigerant fault rectification	
Possible cause	<ul style="list-style-type: none"> ■ R32 refrigerant of IDUs leaks. ■ R32 refrigerant sensor is damaged or contaminated with external foreign matter (e.g. steam, oil) ■ Abnormal communication among IDU main control board, adapter board and R32 refrigerant detection device control board ■ IDU main control board or adapter board or R32 refrigerant detection device control board damaged 	
Troubleshooting	<div style="text-align: center;">  <pre> graph TD Start([A11]) --> D1{Are there any R32 refrigerant leaks in the pipes?} D1 -- Yes --> A1[Follow the instructions of Note (1)] D1 -- No --> D2{Replace the main control board of the IDU. Is the fault cleared?} D2 -- Yes --> B1[Fault cleared] D2 -- No --> D3{R32 refrigerant sensor has been damaged or contaminated by external foreign matter} D3 -- Yes --> A2[Replace R32 refrigerant sensor] D3 -- No --> A3[Contact the technical support personnel of your dealer] </pre> </div> <p>Note 1: Adapter board ENC1 dip switch setting When the function of determining refrigerant</p>	

leakage fault is effective, if the communication abnormality between indoor unit main control board, adapter board and R32 refrigerant detection device control board lasts for more than 2 minutes (see "C79" fault handling in this manual for the communication abnormality handling method between indoor unit main control board and adapter board, and see R32 refrigerant detection device control board operation and installation manual for the communication abnormality handling method between adapter board and R32 refrigerant detection device control board), "A11" fault will be triggered by mistake.

Note 2:

Step 1: Refrigerant leakage inspection method and refrigerant leakage treatment

(1) Check whether there is refrigerant leakage in the field pipeline. Inspection method: if the system is connected with the refrigerant block device, use the refrigerant pressure gauge to connect the liquid test or gas test maintenance needle valve of the refrigerant block device; if the system is not connected with the refrigerant block device, use the refrigerant pressure gauge to connect the liquid test or gas test maintenance needle valve of the outdoor unit. Measure the refrigerant saturation gauge pressure in the field pipeline. If the measured liquid side or gas side refrigerant saturation pressure is less than the standard saturation pressure (see the table of R32 refrigerant ambient temperature and standard saturation gauge pressure in the attached table of this manual), it is determined that there is refrigerant leakage. Follow these steps to handle refrigerant leaks:

- As shown in the figure below, use the refrigerant recovery device to recover the refrigerant in Part 1 and Part 2 respectively. Note: 1) The recovery device must be connected to the liquid/gas side needle valve at the same time to ensure that the residual refrigerant in the liquid pipe and the air pipe is recovered completely; 2) For the recovery of Part 1, it is necessary to enter the outdoor unit engineering menu and select the vacuumizing mode to ensure that all valve bodies of the outdoor unit are in the open state.

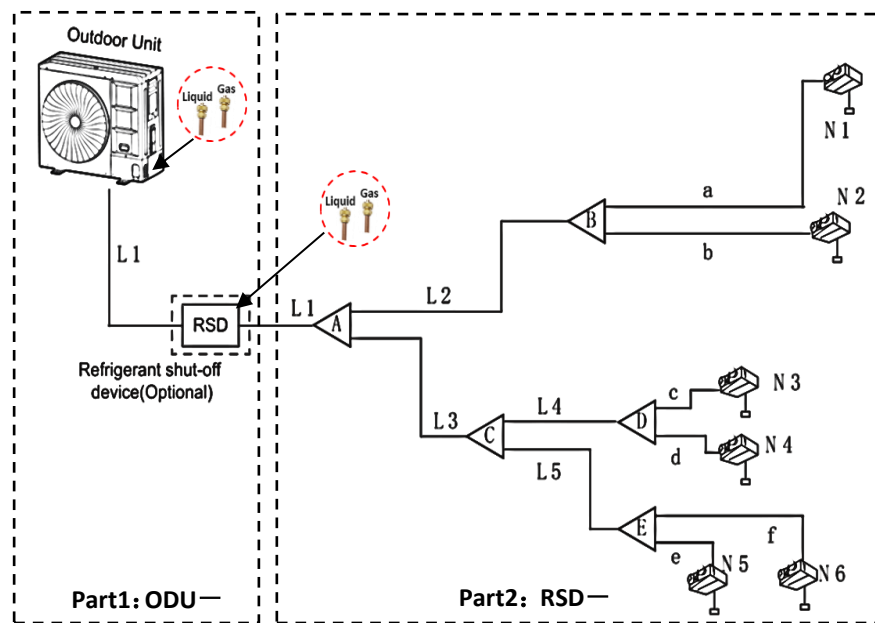

- Locate and repair pipeline leaks.
- After the repair is completed, the system is tested for gas tightness, refer to the Owner's and installation manual for details. If the gas tightness test is passed, go to the next step, otherwise repeat the step above until the gas tightness test is passed
- Replace the R32 sensor model of the faulty IDU.
- Recharge refrigerant according to the ODU Installation Manual.

(2) If the measured refrigerant saturation pressure on the liquid side or gas side is equal to the

standard saturation pressure (see Table of Ambient Temperature and Standard Saturation Pressure of R32 attached to this manual), confirm whether there is a refrigerant leak by using refrigerant testing instruments. If it is determined that there is a refrigerant leak, please operate the refrigerant leak handling procedure above.

Step 2: Reset the R32 refrigerant detection device.

Refer to Figure 1 below. After the refrigerant leakage alarm, the red LED (LED 2) in the R32 refrigerant detection device lights up once every 1s, and the buzzer sounds once every 1s. After maintenance, press and hold the S1 key on the control panel for 10s to reset. After resetting, all LEDs are on for 2S and then go out, and the buzzer stops ringing. The R32 sensor life timing recorded by EERPOM on the control panel is cleared.

Step 3: Wired controller reset operation.

When the wired controller receives the refrigerant leakage fault command transmitted by the indoor unit, the interface will display the "A11" code, and the buzzer will sound once every 1s. After the above step 1/2 is completed and the R32 refrigerant leakage alarm signal is OFF, enter the wired controller engineering parameter setting menu to select the parameter: refrigerant leakage fault reset. After the reset is completed, the interface will no longer display the "A11" code, and the buzzer stops ringing. Note: If the R32 refrigerant leakage alarm signal = ON, the reset operation is invalid!

Figure 1 Schematic diagram of the R32 refrigerant leakage detection system

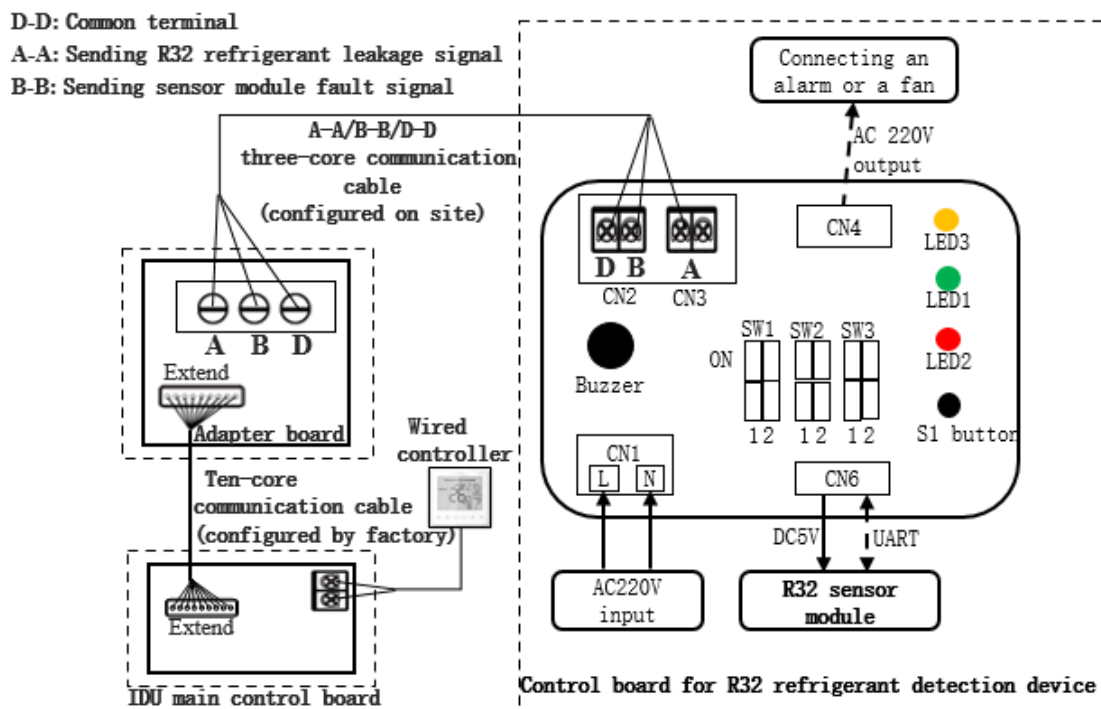

Note: The A/B/D wet printed numbers on the adapter board and the R32 refrigerant detection device control board are only used for the connection of the communication line. Please refer to the corresponding requirements in the installation instructions of the adapter board and the R32 refrigerant detection device control board when connecting the communication line on site.

11.6 A51 - ODU fault

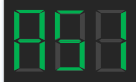
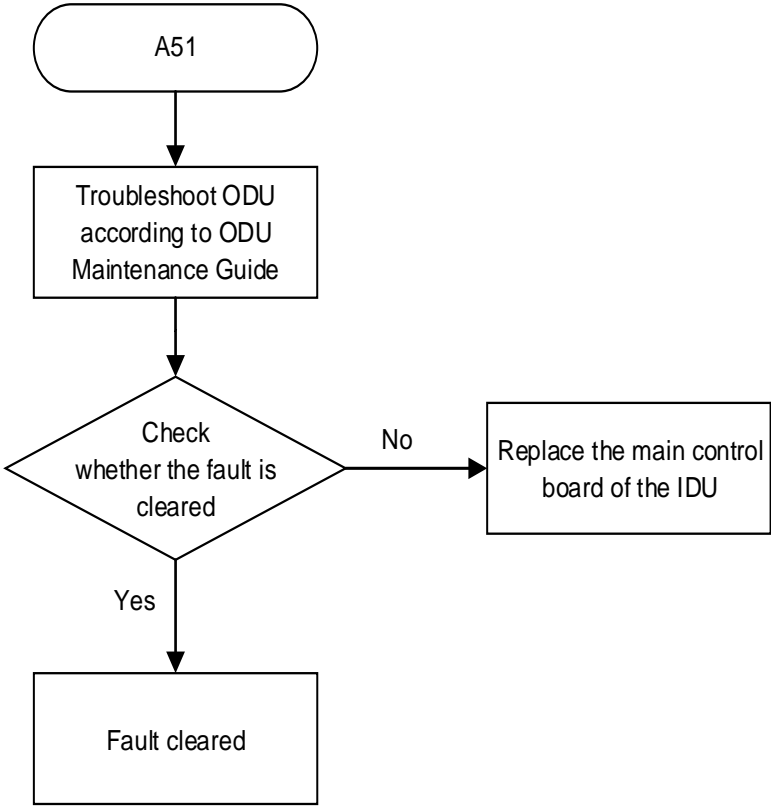
Error display	Digital display	Display position
		Panel, display box, and wired controller
Error impact	The faulty IDU and other IDUs of the same system: The fan continues running, the EEV is closed, and code "A51" is displayed (V6 platform IDU displays the code "Ed")	
	ODU of the same system: <ul style="list-style-type: none"> ■ stops. ■ The displayed code depends on the error type of the ODU. For the meaning of the code, please refer to the error table specific to the model of the ODU. 	
Error trigger	Duration of ODU error \geq 10 minutes	
Error recovery	Automatic recovery	
Possible cause	<ul style="list-style-type: none"> ■ The ODU error is transmitted to the IDU. ■ The IDU main control board is damaged. 	
	<div style="text-align: center;">  <pre> graph TD A51([A51]) --> B[Troubleshoot ODU according to ODU Maintenance Guide] B --> C{Check whether the fault is cleared} C -- No --> D[Replace the main control board of the IDU] C -- Yes --> E[Fault cleared] </pre> </div>	
Troubleshooting		

11.7 A74 - The error of the AHU Kit slave unit is sent to the master unit

Note: When multiple AHU Kits are connected in parallel, the master AHU Kit (referred to as the master) communicates with the ODU, and the slave AHU Kit (referred to as the slave) communicates with the master unit. When the slave fails, the slave unit sends a fault signal to the master unit, and the master unit displays 'A74' (the slave fault).

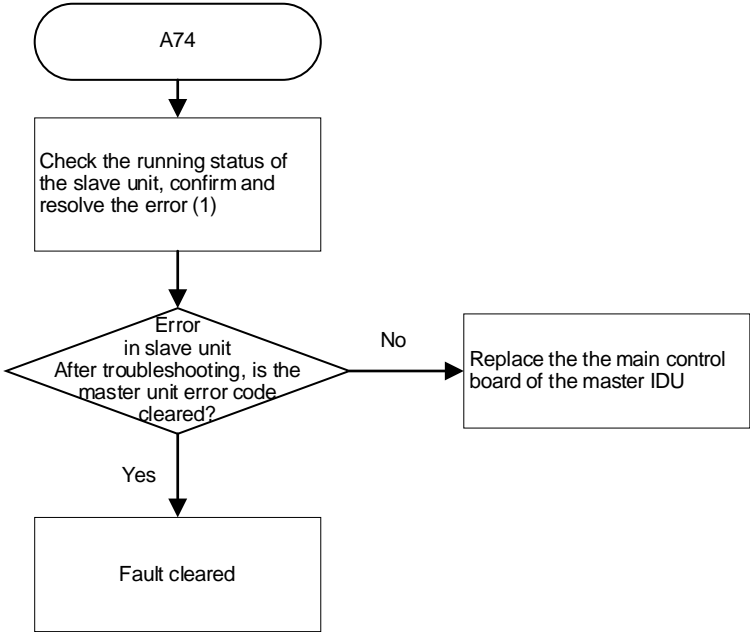
Error display	Digital display	Display position (master)
		Display box and wired controller*
Error impact	Master unit and slave unit: stop. Other IDUs of the same system: operate normally.	
	ODU of the same system: operate normally.	
Error trigger	The error of the slave unit is sent to the master unit	
Error recovery	Automatic recovery	
Possible cause	<ul style="list-style-type: none"> ■ The slave unit is faulty. ■ The master unit's main control board is damaged. 	
Troubleshooting	<div style="text-align: center;">  <pre> graph TD Start([A74]) --> Step[Check the running status of the slave unit, confirm and resolve the error (1)] Step --> Decision{Error in slave unit After troubleshooting, is the master unit error code cleared?} Decision -- Yes --> End([Fault cleared]) Decision -- No --> Action[Replace the the main control board of the master IDU] </pre> </div> <p>Note: 1. When the display box or wired controller is connected to the slave unit, fault codes can be queried (when repairing on site, the display box or wired controller of the main unit can be temporarily removed and connected to the slave unit)</p>	

11.8 A81 - Self-check fault

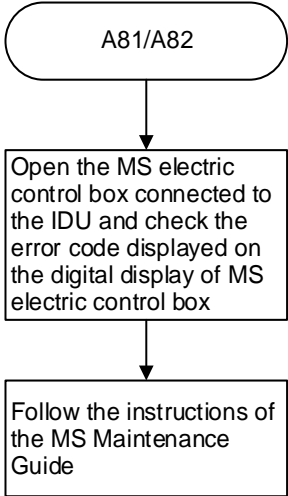
	Digital display	Display position
Error display		Panel, display box, and wired controller
Error impact	Faulty IDU: stops. Other IDUs of the same system: <ul style="list-style-type: none"> ■ IDUs that share the same MS with the faulty IDU will stop operating, while other IDUs remain in operation. ■ IDUs that share the same MS with the faulty IDU display the code "A81" (V6 platform IDU displays the code "A8"). Meaning of the code: MS self-check fault); IDUs that are connected to other MSs work properly. 	
	ODU of the same system: <ul style="list-style-type: none"> ■ stops. ■ V8 platform ODU displays the code "A81", and V6 platform ODU displays the code "A8". Meaning of the code: MS self-check fault) 	
Error trigger	The MS self-check fault lasts for at least 10 min	
Error recovery	The fault is cleared if one of the following conditions is met: <ul style="list-style-type: none"> ■ Automatic recovery 30 min after the MS fault is cleared ■ Power on again 	
Possible cause	<ul style="list-style-type: none"> ■ A fault may occur during the MS self-check process. 	
Troubleshooting	 <pre> graph TD Start([A81/A82]) --> Step1[Open the MS electric control box connected to the IDU and check the error code displayed on the digital display of MS electric control box] Step1 --> Step2[Follow the instructions of the MS Maintenance Guide] </pre>	

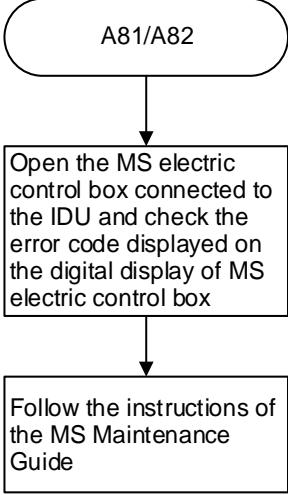

11.9 A82 - MS (refrigerant flow direction switching device) fault

Faulty IDU	Digital display	Display position
		Panel, display box, and wired controller
Error impact	<p>Faulty IDU: The fan continues running, and the EEV is closed. Other IDUs of the same system:</p> <ul style="list-style-type: none"> ■ IDUs that share the same MS with the faulty IDU: The fan continues running, and the EEV is closed. Other IDUs remain in operation. ■ IDUs that share the same MS with the faulty IDU: V8 platform IDU displays the code "A82", and V6 platform IDU displays the code "F8". Meaning of the code: MS fault. IDUs that are connected to other MSs work properly. 	
	<p>ODU of the same system:</p> <ul style="list-style-type: none"> ■ Shutdown ■ V8 platform ODU displays the code "A82" (V6 platform ODU displays the code "F8". Meaning of the code: MS fault) 	
Error trigger	When the IDU receives a fault signal from MS	
Error recovery	Automatic recovery (Note: Duration from fault triggering to automatic recovery is at least 30 min)	
Possible cause	The MS is faulty.	
Troubleshooting	<div style="text-align: center;">  <pre> graph TD A([A81/A82]) --> B[Open the MS electric control box connected to the IDU and check the error code displayed on the digital display of MS electric control box] B --> C[Follow the instructions of the MS Maintenance Guide] </pre> </div>	

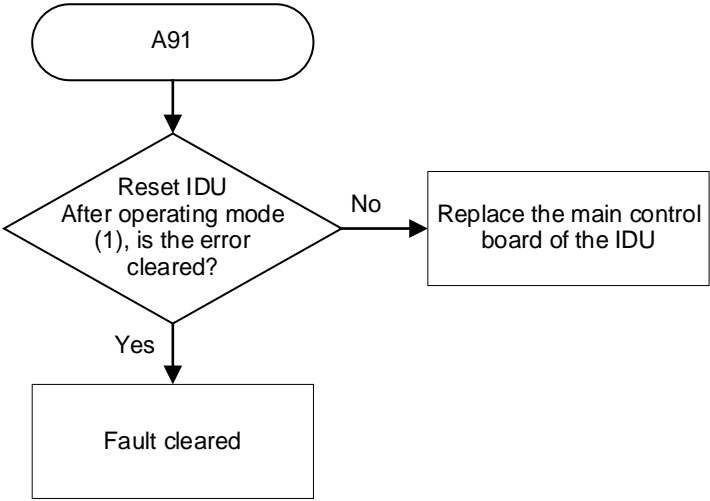
11.10 A91 - Mode conflict (SDV5 PQE communication protocol adopted)

Error display	Digital display	Display position
		Panel, display box, and wired controller (Note: Error codes are displayed 2 minutes after faults are triggered)
Error impact	Faulty IDU: The fan continues running, and the EEV is closed. Other IDUs of the same system: operate normally.	
	ODU of the same system: operate normally.	
Error trigger	<ul style="list-style-type: none"> ■ The ODU is running in heating mode, and the IDU is running in cooling mode or dehumidification mode. ■ The ODU is running in heating mode, and the IDU is running in fan mode (note: the wired controller can be used to set whether the heating mode conflicts with the fan mode). ■ The ODU is running in cooling mode, and the IDU is running in heating mode. 	
Error recovery	Automatic recovery	
Possible cause	<ul style="list-style-type: none"> ■ The operation mode of IDU conflicts with that of the ODU. ■ The IDU main control board is damaged. 	
Troubleshooting	<div style="text-align: center;">  <pre> graph TD A91([A91]) --> D{Reset IDU After operating mode (1), is the error cleared?} D -- Yes --> FC[Fault cleared] D -- No --> RMCB[Replace the main control board of the IDU] </pre> </div> <p>Note:</p> <ol style="list-style-type: none"> 1. For all IDUs in the heat pump system (Except for DC Fresh Air Processing Unit): 1) When the ODU is running in heating mode, the IDU can only operate in heating mode. If you would like to use the fan mode for the IDU, the wired controller needs to be used to change the settings (for more instructions on how to change settings, refer to "Instruction for Use of the wired controller"). 2) When the ODU is running in cooling mode, the IDU can operate in cooling mode or fan mode. 	

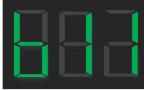
11.12 b11, b13 - Error in 1# electronic expansion valve coil, error in 2# electronic expansion valve coil

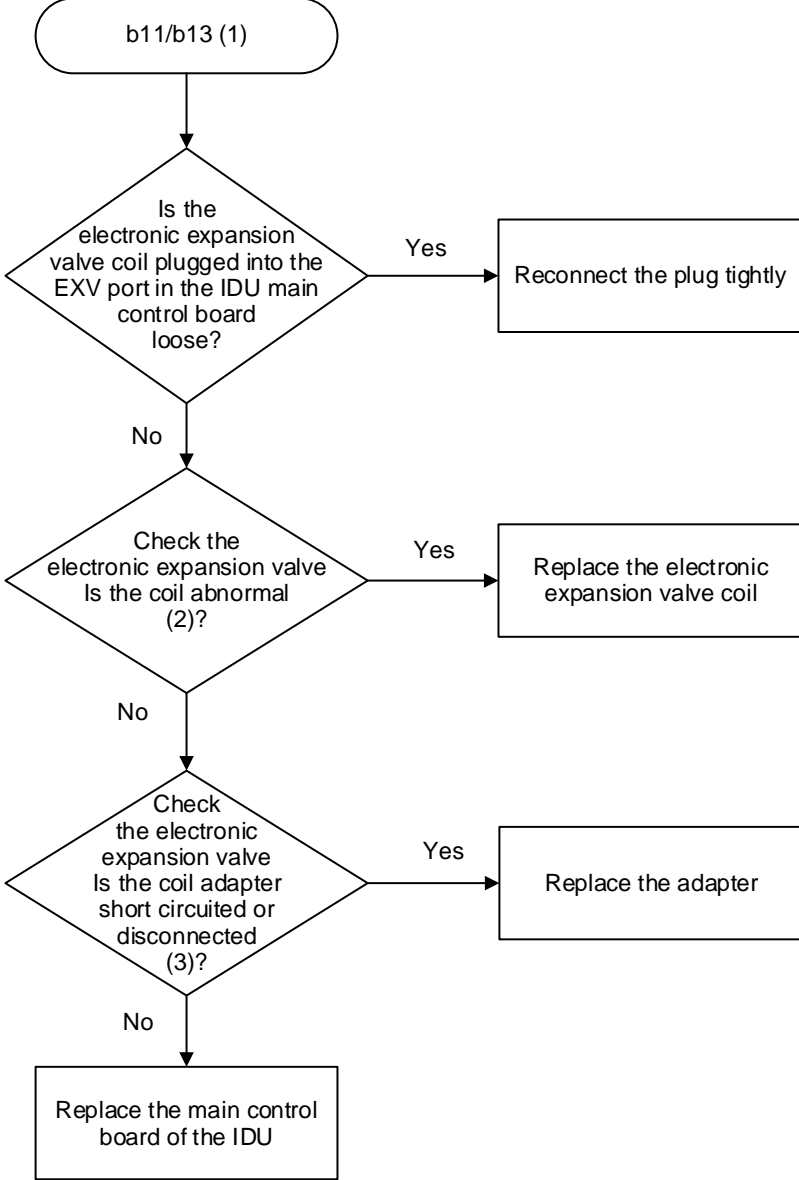
Error display	Digital display		Display position
			Panel, display box, and wired controller
Error impact	The faulty IDU stops. Other IDUs of the same system: operate normally. ODU of the same system: operate normally.		
Error trigger	The IDU main control board cannot detect the feedback signal from the electronic expansion valve coil for no less than 4 seconds.		
Error recovery	After the unit is powered on again, the main control program detects a feedback signal from the electronic expansion valve.		
Possible cause	<ul style="list-style-type: none"> ■ The electronic expansion valve coil plugged into the EEV port in the IDU main control board is loose. ■ The IDU main control board is damaged. ■ The electronic expansion valve coil is faulty. ■ The electronic expansion valve coil is short circuited or disconnected. 		
Troubleshooting	<div style="text-align: center;">  <pre> graph TD Start([b11/b13 (1)]) --> D1{Is the electronic expansion valve coil plugged into the EXV port in the IDU main control board loose?} D1 -- Yes --> A1[Reconnect the plug tightly] D1 -- No --> D2{Check the electronic expansion valve Is the coil abnormal (2)?} D2 -- Yes --> A2[Replace the electronic expansion valve coil] D2 -- No --> D3{Check the electronic expansion valve Is the coil adapter short circuited or disconnected (3)?} D3 -- Yes --> A3[Replace the adapter] D3 -- No --> A4[Replace the main control board of the IDU] </pre> </div> <p>Note:</p>		

1. The error code corresponds to the following two situations:

- a. If there is only one electronic expansion valve port on the main control board of the IDU, when an error occurs in the electronic expansion valve coil connected to the EEV port, the error code is b05.
- b. If there are two electronic expansion valve ports on the main control board of the IDU named EEV1 and EEV2, when an error occurs in the electronic expansion valve coil connected to port EEV1, the error code is b05; when an error occurs in the electronic expansion valve coil connected to port EEV2, the error code is b07.

2. In Figure 1 below: The numbers 1 to 5 stand for the pins of different colours paired with individual wires which have the same colour as the pin. 5(com) is a pin of the common terminal, and number 6 is a null pin without any wire connected; an XHP coil plug is used to connect to the EEV port of the main control board, and an APM coil plug is used to connect to the A-direction plug of the adapter wire (see Figure 2 below). Table 1 shows the resistance between pin 1-4 and pin 5 (the common terminal) when the electronic expansion valve coil is in a normal state. If the resistance is near zero or significantly deviates from its normal state, the coil is damaged.

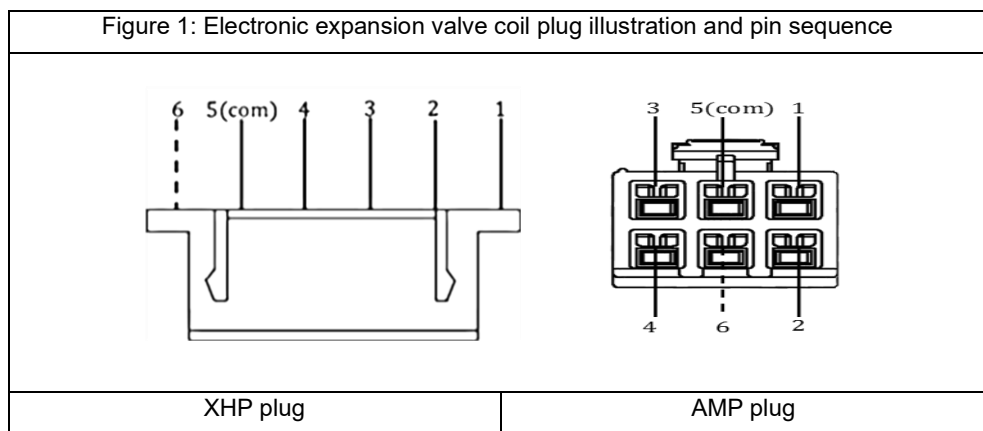
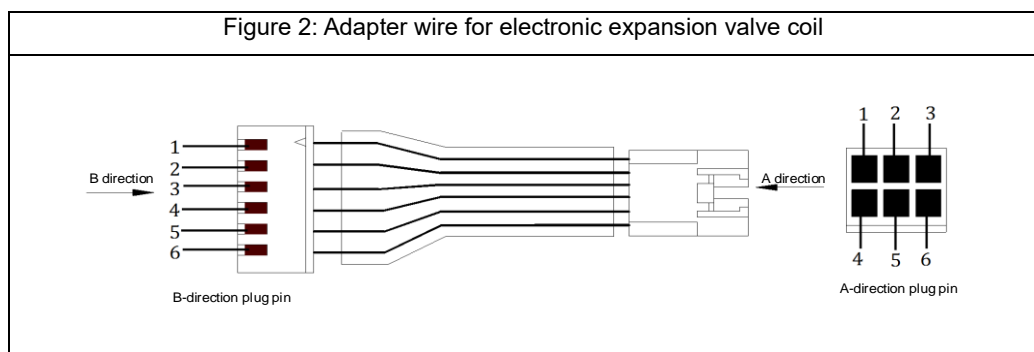

Table 1: Resistance between pins with an electronic expansion valve coil in normal condition

Pin measured	Resistance in normal status
1-5	40-50Ω
2-5	40-50Ω
3-5	40-50Ω
4-5	40-50Ω

3. When the distance between the throttle part and the main control board of the IDU in need of connection is too great, you will need an adapter wire for the electronic expansion valve coil. This is shown in Figure 2 below: Use a multimeter to measure the resistance between the pin in the plug at end A of each wire and at end B. A resistance value close to 0 indicates a short circuit has occurred in the wire, and a resistance value close to infinity indicates an open circuit of the wire.

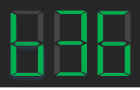
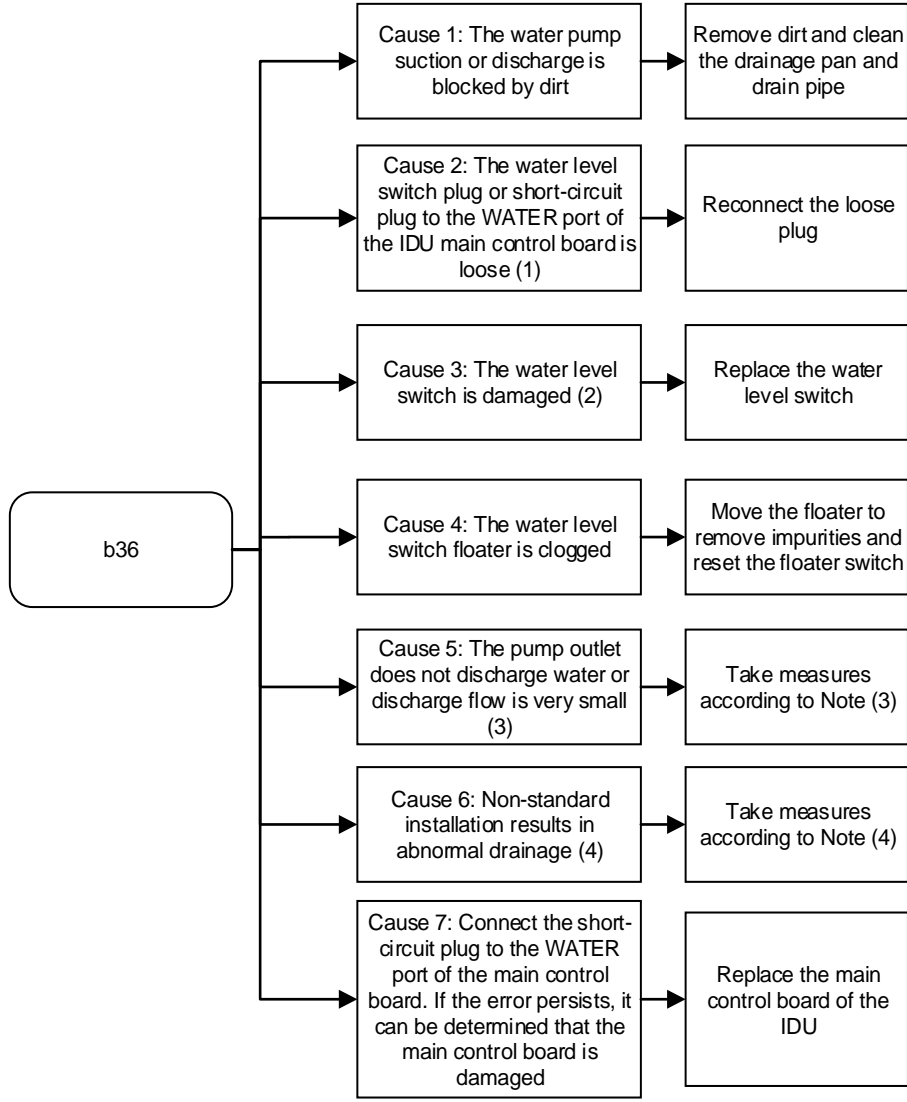

11.13 b36 - Water level switch alarm error

Error display	Digital display	Display position
		Panel, display box, and wired controller
Error impact	The faulty IDU stops. Other IDUs of the same system: operate normally.	
	ODU of the same system: operate normally.	
Error trigger	The water level switch alarm is triggered when the floater of the water level switch rises to the warning water level and lasts for 5 min.	
Error recovery	Automatic recovery	
Possible cause	<ul style="list-style-type: none"> ■ The drain pump/water level switch is damaged. ■ Water level switch float is stuck by a foreign object ■ The water level switch plug or short-circuit plug to the WATER port of the IDU main control board is loose. ■ Non-standard installation results in abnormal drainage: The drain pipe is blocked; the improperly sloped drain pipe causes the condensate water to flow backwards; and the lift of the drain pipe exceeds the allowable value. ■ The IDU main control board is damaged. 	
Troubleshooting	<div style="display: flex; align-items: center; justify-content: center;"> <div style="border: 1px solid black; border-radius: 15px; padding: 5px 15px; margin-right: 20px;">b36</div>  </div> <pre> graph LR b36[b36] --> C1[Cause 1: The water pump suction or discharge is blocked by dirt] b36 --> C2[Cause 2: The water level switch plug or short-circuit plug to the WATER port of the IDU main control board is loose (1)] b36 --> C3[Cause 3: The water level switch is damaged (2)] b36 --> C4[Cause 4: The water level switch floater is clogged] b36 --> C5[Cause 5: The pump outlet does not discharge water or discharge flow is very small (3)] b36 --> C6[Cause 6: Non-standard installation results in abnormal drainage (4)] b36 --> C7[Cause 7: Connect the short-circuit plug to the WATER port of the main control board. If the error persists, it can be determined that the main control board is damaged] C1 --> A1[Remove dirt and clean the drainage pan and drain pipe] C2 --> A2[Reconnect the loose plug] C3 --> A3[Replace the water level switch] C4 --> A4[Move the floater to remove impurities and reset the floater switch] C5 --> A5[Take measures according to Note (3)] C6 --> A6[Take measures according to Note (4)] C7 --> A7[Replace the main control board of the IDU] </pre> <p>Note:</p>	

1. The plug attached to the WATER port of the main control board corresponds to the following two cases:
 - a. The factory default of IDUs without a water level switch uses a short-circuit plug to seal the WATER port.
 - b. IDUs with a water level switch use a water level switch plug to seal the WATER port.
2. Use a multimeter to measure the resistance between the pins corresponding to the two wires of the water level switch plug. 1) After the floater of the water level switch is moved upwards to the highest position, the water level switch is in a short-circuited state, and the resistance value is infinite. 2) After the floater of the water level switch is moved downwards to the lowest position, the water level switch is closed, and the resistance value is less than 1Ω . If the detected resistance value does not meet the above values, the water level switch is damaged.
3. Possible causes and solutions for the situation where the pump outlet does not discharge water or the discharge flow is very small: 1) The water pump plug to the PUMP port in the IDU main control board is loose. Reconnect it firmly. 2) The drain pump suction impeller is clogged. Remove the debris causing the clog to make the pump continue running. 3) If the error cannot be cleared after implementing solutions for causes 1) and 2), the drain pump body is damaged. Replace the drain pump.
4. Possible causes and solutions for abnormal drainage due to non-standard installation: 1) If the drain pipe is blocked, remove the debris and clean the drainage pan and the drain pipe of the IDU. 2) If the drain pipe is improperly installed, which causes the condensate water to flow backward, tilt the IDU to the drainage side by a certain gradient (inclination $\geq 1\%$). The centralized drain pipe must be lower than the drainage outlet of the unit. Air outlets must be placed at the highest horizontal pipeline (see Installation and Operation Manual of IDUs). 3) If the lift of the drain pipe exceeds the allowable value, reduce the vertical height of the drain pipe or replace the drain pump with the one which has a higher lift.

11.14 C11 - Duplicate IDU address code

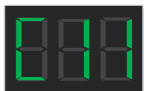
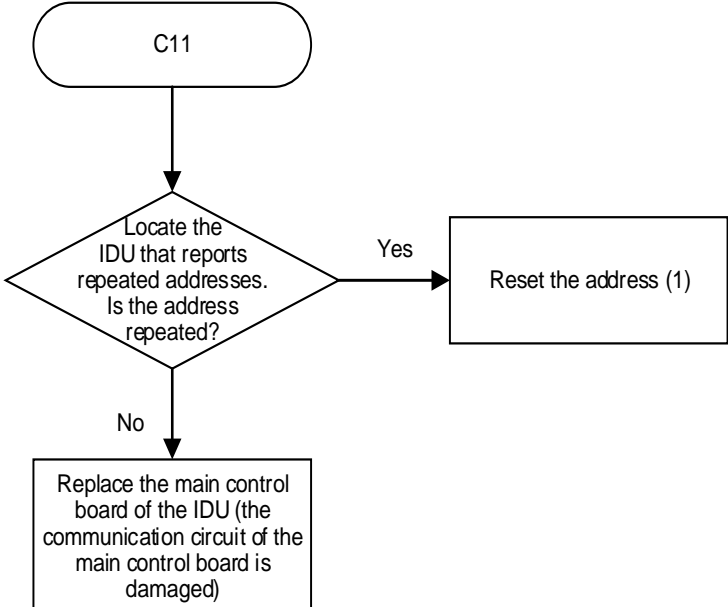
Error display	Digital display	Display position	
		Panel or display box	Wired controller
		Error code and address code are displayed alternately (2)	Error code and address code flash simultaneously
Error impact	<p>Faulty IDU: The fan continues running, and the EEV is closed. Other IDUs of the same system: The fan continues running, the EEV is closed, and error code "A51" is displayed (V6 platform IDU displays the code "Ed"). Meaning of the code: ODU fault</p> <p>ODU of the same system:</p> <ul style="list-style-type: none"> ■ Stop. ■ Error code "C26" is displayed (V6 platform ODU displays the code "H7"). Meaning of the code: IDU qty decrease fault 		
Error trigger	Repeated address codes for IDU		
Error recovery	Automatic recovery		
Possible cause	<ul style="list-style-type: none"> ■ Duplicate IDU address code (▲) ■ The IDU main control board is damaged. 		
Troubleshooting	<div style="text-align: center;">  <pre> graph TD C11((C11)) --> D{Locate the IDU that reports repeated addresses. Is the address repeated?} D -- Yes --> R1[Reset the address (1)] D -- No --> R2[Replace the main control board of the IDU (the communication circuit of the main control board is damaged)] </pre> </div> <p>(▲): The common reasons for address code duplication are as follows:</p> <ol style="list-style-type: none"> 1. After replacing the main control board, the address was not reset, resulting in address duplication. The address can be manually set using the controller or the indoor unit address can be cleared at the outdoor unit and then automatically addressed again. 2. In systems where the nominal capacity of an indoor unit is greater than or equal to 20KW, the indoor unit usually occupies more than two addresses (one real address + several virtual addresses, see Note 1 below), which may cause the addresses of other indoor units in the system to duplicate with the virtual addresses of the large indoor unit. In this case, the indoor unit address can be cleared at the outdoor unit and then automatically addressed again, or the controller can be used to manually set the address to avoid duplicate codes when the duplicate address code is known. <p>Note:</p>		

1. The following table shows the number of addresses and address codes for any indoor unit (AHU kit/direct expansion unit not applicable) with different capacities (HP)

Nominal capacity (kW)	capacity (HP)	Number of IDUs (N)	Number of addresses (N)	Address code	Address code to be queried at the centralized controller or wired controller (★)
kW<20	HP<7	1	1	Address code can be any integer from 0 to 63, denoted by X	X
20≤kW<40	7≤HP<14	1	2	The address code can be any integer from 0 to 62, denoted by X, and the virtual address following it is X+1	X
40≤kW<78.5	14≤HP<28	1	4	The address code can be any integer from 0 to 60, denoted by X, and the virtual addresses following it are: X+1, X+2, X+3	X
78.5≤kW<101	28≤HP<36	1	5	The address code can be any integer from 0 to 59, denoted by X, and the virtual addresses following it are: X+1, X+2, X+3, X+4	X
101≤kW<112	36≤HP<40	1	6	The address code can be any integer from 0 to 58, denoted by X, and the virtual addresses following it are: X+1, X+2, X+3, X+4, X+5	X
kW>112	HP>40	1	8	The address code can be any integer from 0 to 56, denoted by X, and the virtual addresses following it are: X+1, X+2, X+3, X+4, X+5, X+6, X+7	X

★Example: If one IDU is 5 HP and the address code is set to 1, then the query address at the centralized

controller side or wired controller side is 1. If one IDU is 20 HP and the address code is set to 5, then this IDU has four address codes, which are 5, 6, 7, and 8, but the query address at the centralized controller side or wired controller side is 5.

2. Repeated display of address codes and confirmation of repeated address codes

	Error code	Display box/panel	Wired controller
IDU with repeated address codes (number of addresses N = 1)	C11	Error code "C11" and address code are displayed alternately every 1s (★1)	Error code "C11" is displayed
IDU with repeated address codes (number of addresses N>1)	C11	If the number of repeated address codes is 1, then the error code "C11" is displayed alternately with the minimum address code every 1s. If the number of repeated address codes is >1, then the error code "C11" is displayed alternately with the minimum address code every 1s; (★2)	Error code "C11" is displayed

★ Example 1: If IDU 1 is 5 HP and the address code is set to 1, and IDU 2 is 5 HP and the address code is set to 1 too, then the display box or panel of IDU 1 and IDU 2 will alternately display the code C11 and the address code 1.

★Example 2: If IDU 1 is 20 HP and the address code is set to 1 (the addresses actually occupied are 1, 2, 3, and 4), IDU 2 is 5 HP and the address code is set to 2, IDU 3 is 5 HP and the address code is set to 3, then the display box or panel of IDU 1 will alternately display the code C11 and the address code 2 (If there are multiple repeated addresses, then the minimum address code is displayed); the display box or panel of IDU 2 will alternately display the code C11 and the address code 2; and the display box or panel of IDU 3 will alternately display the code C11 and the address code 3.

11.15 C21 - Abnormal communication between IDU and ODU

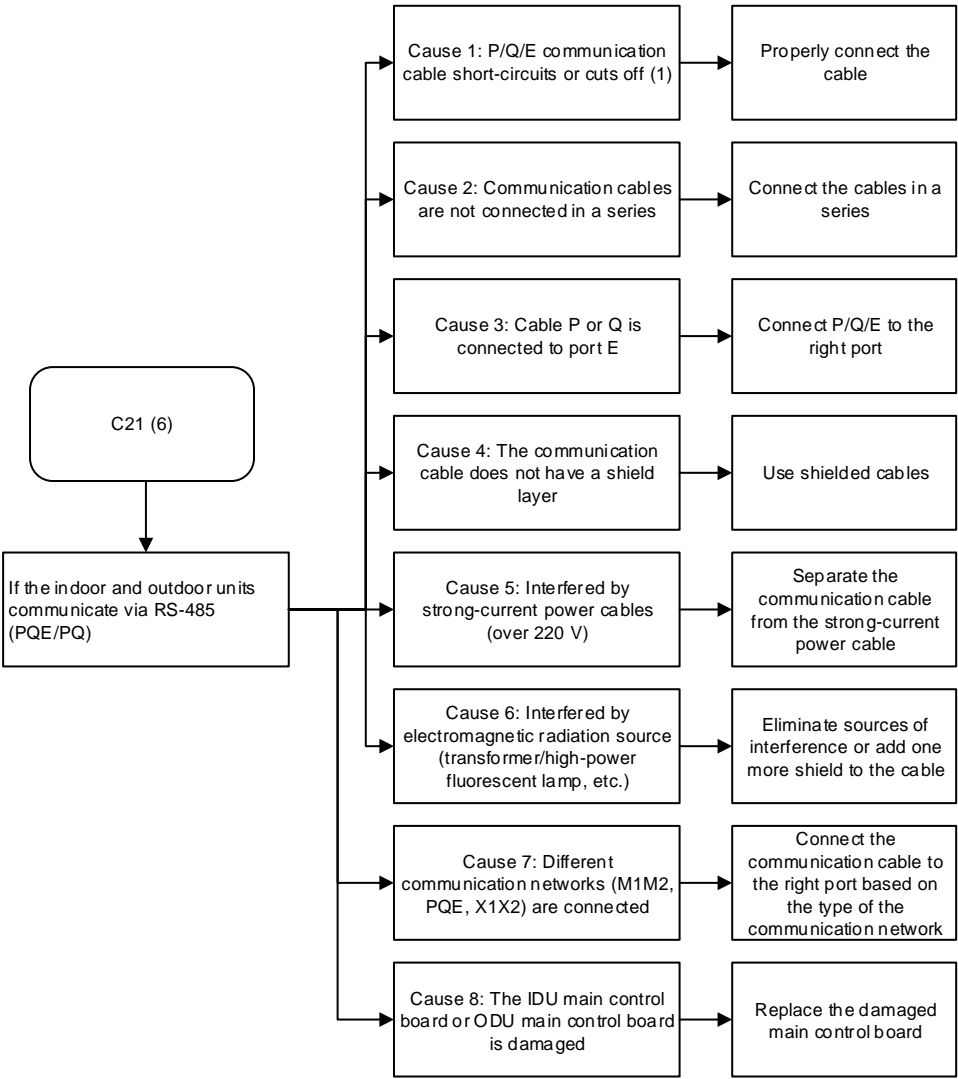
Error display	Digital display	Display position
		Panel, display box, and wired controller
Error impact	Faulty IDU: The fan continues running, and the EEV is closed. Other IDUs of the same system: The fan continues running, the EEV is closed, and error code "A51" is displayed (V6 platform IDU displays the code "Ed"). Meaning of the code: ODU fault ODU of the same system: <ul style="list-style-type: none"> ■ stops. ■ Error code "C26" is displayed (V6 platform ODU displays the code "H7"). Meaning of the code: IDU qty decrease fault 	
Error trigger	If the IDU has not received any communication signal from ODU for 2 min	
Error recovery	Automatic recovery	
Possible cause	See the Troubleshooting section.	
Troubleshooting	<p>■ If the indoor and outdoor units communicate via RS-485(PQE/PQ):</p> <div style="text-align: center;">  </div> <p>Note 1: If you measure the resistance between ports P, Q, and E of the IDU main control board, normally the resistance between P and Q is 120 Ω, the resistance between P and E is infinite, and the resistance between Q and E is infinite.</p>	

Troubleshooting

■ If the indoor and outdoor units communicate via HyperLink (M1M2):

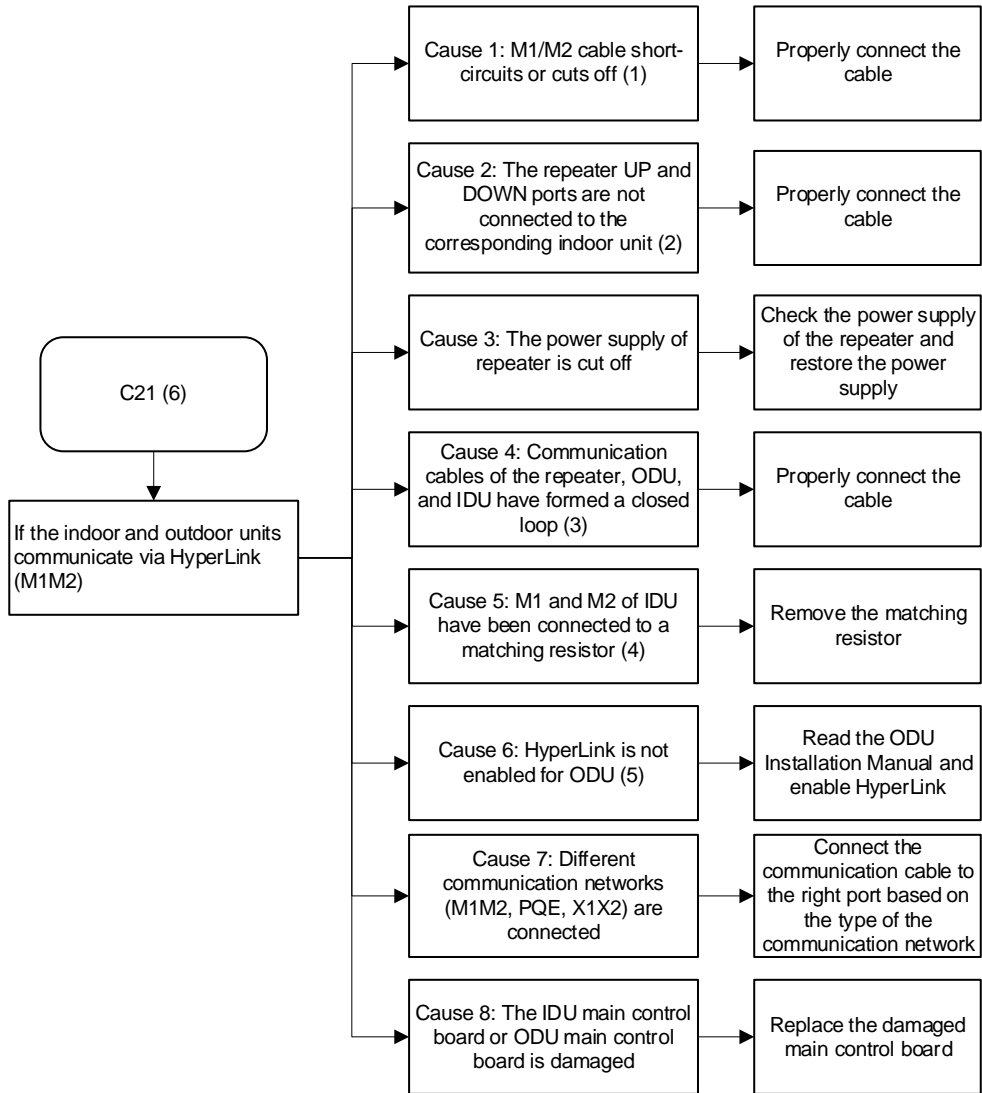

Note:

1. If you measure the resistance between terminal blocks M1 and M2 of the IDU main control board, normally this resistance is greater than 1 MΩ.
2. Figure 1 shows the schematic diagram of HyperLink communication line connection. The connection of repeater wires must comply with the following requirements. Otherwise, an IDU communication fault may occur.

Figure 1 Schematic diagram of HyperLink communication cable connection

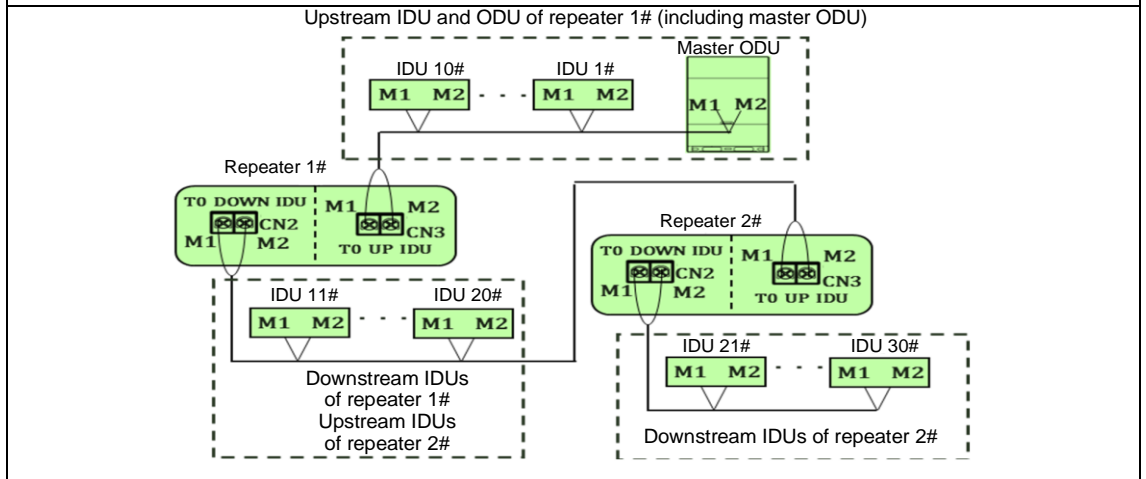

- 1) The UP communication port of 1# repeater is connected to the communication port of 10# IDU, and the DOWN communication port of 1# repeater is connected to the communication port of 11# IDU.
- 2) The UP communication port of 2# repeater is connected to the communication port of 20# IDU, and the DOWN communication port of 2# repeater is connected to the communication port of 21# IDU.
- 3) For each repeater added, 10 IDUs and 200 m communication distance can be added. A refrigerant system allows the addition of a maximum of 2 repeaters and can connect to up to 30 IDUs. If more than 30 IDUs are connected, please allocate separate refrigerant systems.

3. If communication cables connecting the communication ports of the repeater, IDU and ODU form a closed loop, it will cause a communication fault.

4. RS-485 communication cables must be connected hand in hand. If communication is unstable, a matching resistor needs to be added to the last IDU on the PQ (in the accessory bag of the ODU). However, a matching resistor should not be added between M1 and M2. Otherwise, a communication fault may occur.

5. To select the communication mode HyperLink (M1M2), users must go to the ODU menu item to change the mode (For the setting method, refer to the ODU Installation Manual). Otherwise, communication faults may occur.

6. The V8 platform ODU typically uses the V8 communication protocol. If there are any IDUs that use a non-V8 platform, users must go to the ODU menu item to change the communication protocol (Please refer to the ODU Installation Manual for setup instructions). Otherwise, these IDUs will display communication fault codes (For the code number, please refer to the IDU wiring nameplate).

11.16 C51 - Abnormal communication between the IDU and wired controller

Note: The error code C51 can be triggered either at the IDU side or the wired controller side.

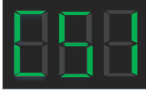
	LED display	Display position
Fault Display		<p>If a powered-on IDU does not receive any message from the wired controller: 1) Wired controller: "C51" is displayed; 2) Panel or display box: The LED display and the error code bit on the spot check interface are displayed normally.</p> <p>If a powered-on IDU receives any message from the wired controller: 1) Wired controller: "C51" is displayed; 2) Panel or display box: The LED display is normal, and "C51" is displayed in the error code bit on the inspection interface.</p>
Fault Impact	<ul style="list-style-type: none"> ■ Triggered at the IDU side: The faulty IDU and other IDUs of the same system operate normally. ■ Triggered at the wired controller side: The wired controller cannot be used. <p>ODU of the same system operates normally.</p>	
Fault Trigger	<ul style="list-style-type: none"> ■ Triggered at the IDU side: The IDU main control board experiences a two-minute communication interruption with the wired controller. ■ Triggered at the wired controller side: The wired controller has not received any reply from the IDU main control board for one continuous minute. 	
Fault Recovery	Automatic recovery	
Possible Cause	<ul style="list-style-type: none"> ■ The wired controller is damaged. ■ The IDU main control board is damaged. ■ Communication wires are loose or the communication port is faulty. ■ Communication wires have short-circuited or been cut off. ■ The communication wire does not meet anti-interference requirements or is affected by strong-current interference. ■ The IDU has no address. 	

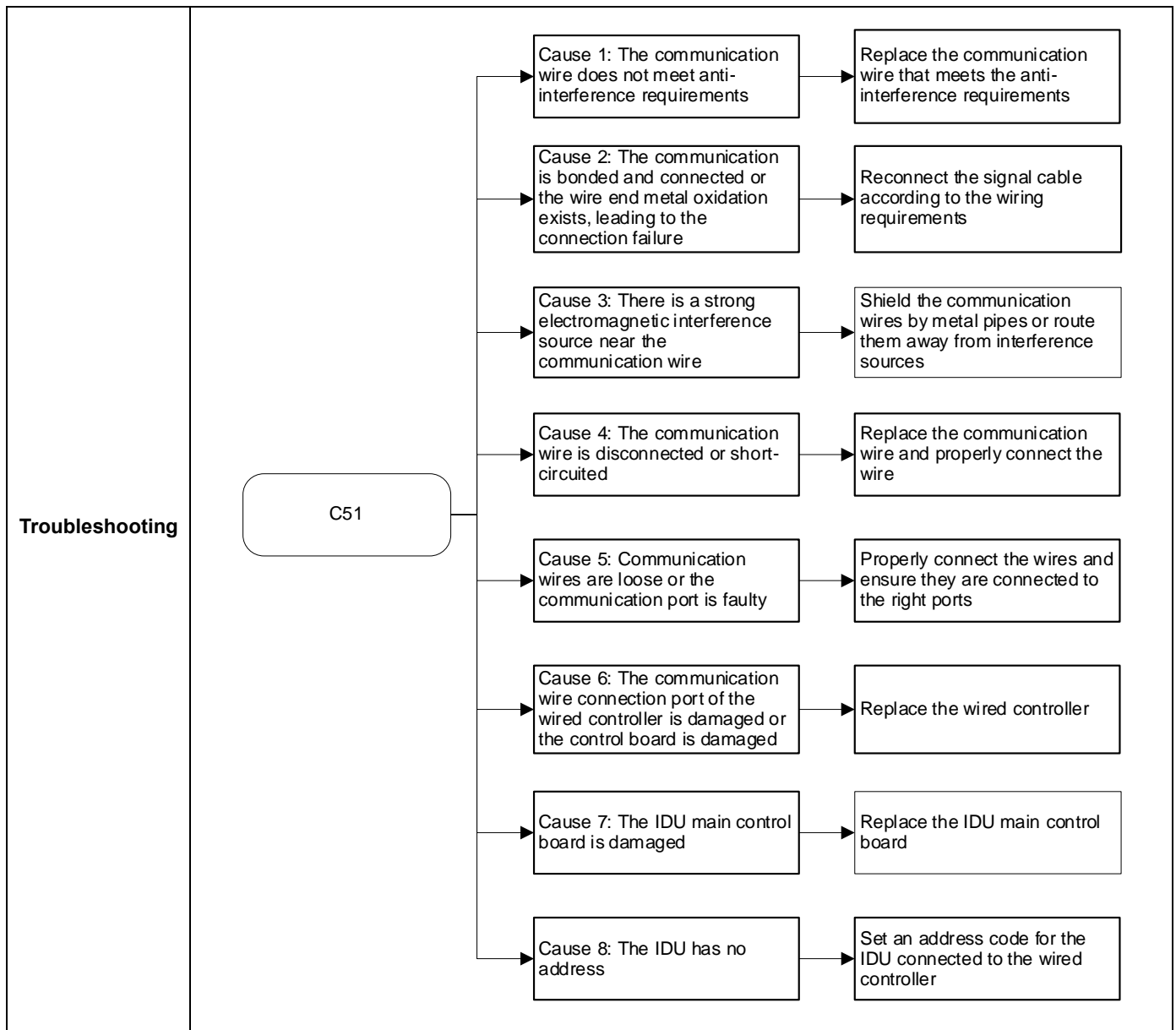

11.17 C61 - Abnormal communication between the IDU main control board and display control board

Note: The error code C61 can be triggered either at the IDU side or at the panel or display box side.

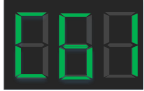
	Digital display	Display position
Error display		<p>After power on, normal communication was not established between the indoor unit and the wired controller:</p> <ol style="list-style-type: none"> 1) The wired controller does not display fault code; 2) The panel or display box displays "C61". <hr/> <p>After power on, normal communication was established between the indoor unit and the wired controller:</p> <ol style="list-style-type: none"> 1) The wired controller displays "C61"; 2) The panel or display box displays "C61".
Error impact	<p>The faulty IDU and other IDUs of the same system: operate normally. ODU of the same system: operate normally.</p>	
Error trigger	<ul style="list-style-type: none"> ■ Triggered at the IDU side: If the main control board of the IDU has been connected to the display board but has not communicated with the display board for 2 min; ■ Triggered at panel or display box side: If the display board has not received any reply from the main control board of an IDU for 1 min 	
Error recovery	<p>Automatic recovery</p>	
Possible cause	<ul style="list-style-type: none"> ■ Unplug the display box or panel communication wire from the main control board of powered indoor unit. ■ Use a wrong port to connect display control board and IDU main control board. ■ The communication wire between the display control board and the IDU main control board has become loose. ■ Short circuit or open circuit in communication wire ■ The display box or panel does not match the indoor unit model. ■ The display control board is damaged. ■ The IDU main control board is damaged. 	

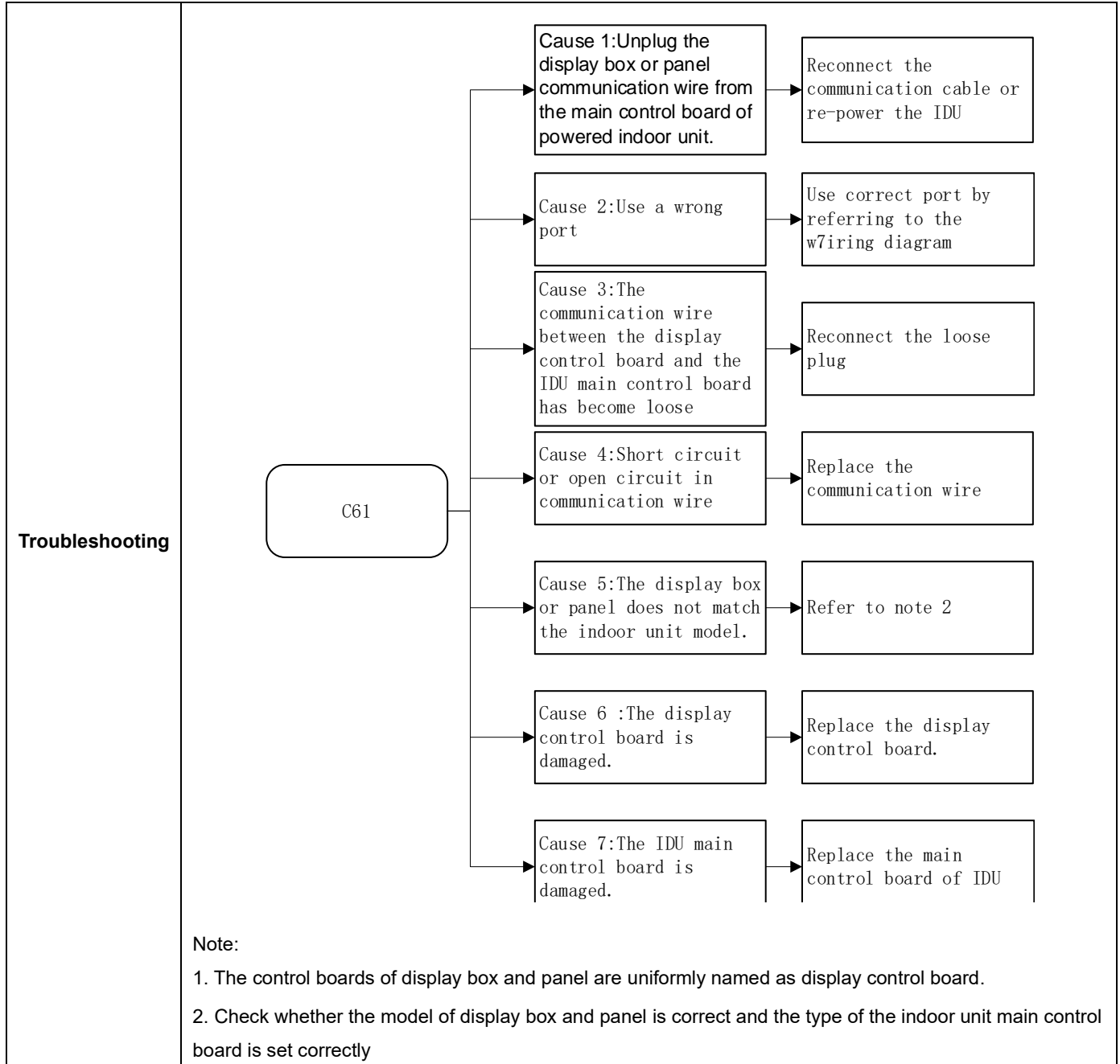

11.18 C71 - Abnormal communication between AHU Kit slave unit and master unit

Note: When multiple AHU Kits are connected in parallel, the master AHU Kit (referred to as the master) communicates with the ODU, and the slave AHU Kit (referred to as the slave) communicates with the master AHU Kit.

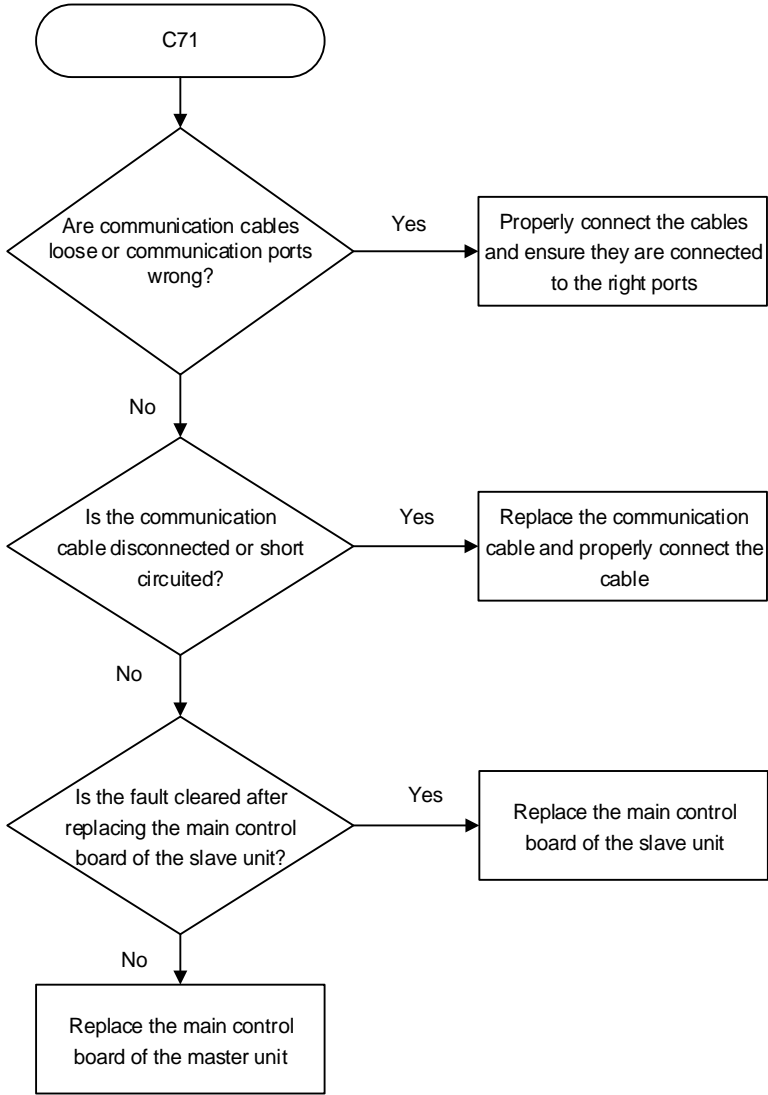
Error display	Digital display	Display position (master)
		Display box or wired controller*
Error impact	Master unit and slave unit: stop. Other IDUs of the same system: operate normally.	
	ODU of the same system: operate normally.	
Error trigger	If the main control board of the master unit has lost communication with the main control board of the slave unit for 2 min;	
Error recovery	Automatic recovery	
Possible cause	<ul style="list-style-type: none"> ■ The slave unit's main control board is damaged. ■ The master unit's main control board is damaged. ■ Communication cables are loose or the communication port is faulty. ■ Communication cables have short-circuited or been cut off. 	
Troubleshooting	 <pre> graph TD Start([C71]) --> D1{Are communication cables loose or communication ports wrong?} D1 -- Yes --> A1[Properly connect the cables and ensure they are connected to the right ports] D1 -- No --> D2{Is the communication cable disconnected or short circuited?} D2 -- Yes --> A2[Replace the communication cable and properly connect the cable] D2 -- No --> D3{Is the fault cleared after replacing the main control board of the slave unit?} D3 -- Yes --> A3[Replace the main control board of the slave unit] D3 -- No --> A4[Replace the main control board of the master unit] </pre>	
	<p>Note: When the display box or wired controller is connected to the slave unit, fault codes can be queried (when repairing on site, the display box or wired controller of the main unit can be temporarily removed and connected to the slave unit).</p>	

11.19 C72 - Number of AHU Kits is not the same as the set number

Note: When multiple AHU Kits are connected in parallel, the master AHU Kit (referred to as the master) communicates with the ODU, and the slave AHU Kit (referred to as the slave) communicates with the master AHU Kit.

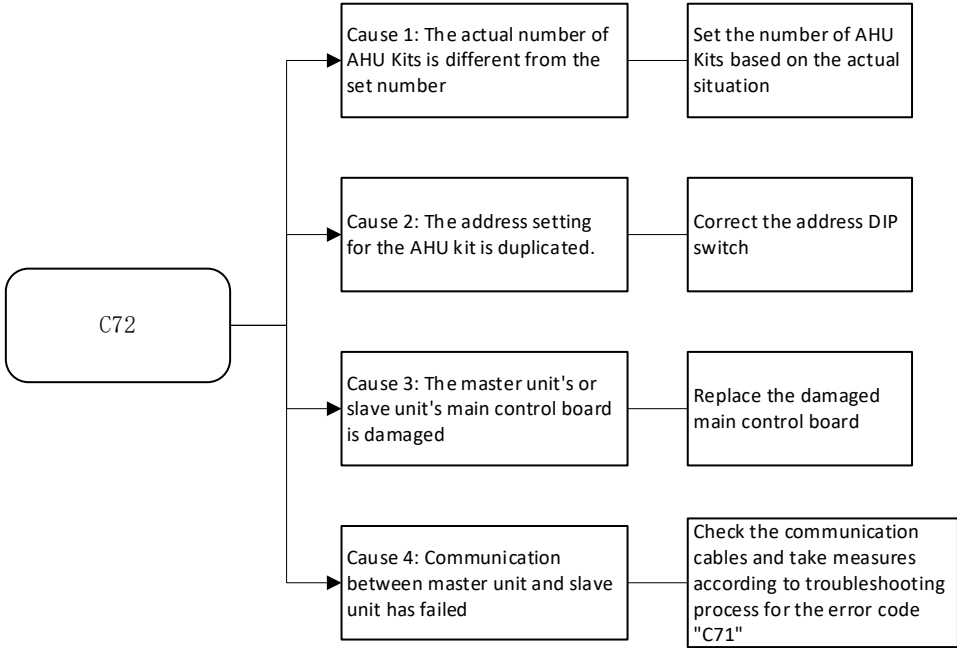
Error display	Digital display	Display position (master)
		Master AHU Kit: Display box or wired controller
Error impact	Master unit and slave unit: stop. Other IDUs of the same system: stops.	
	ODU of the same system: <ul style="list-style-type: none"> ■ stops. ■ Error code "C26" is displayed (V6 platform ODU displays the code "H7"). Meaning of the code: IDU qty decrease fault 	
Error trigger	When it is detected that the number of AHU Kits in operation is different from the set number and this lasts for 3 min	
Error recovery	Automatic recovery	
Possible cause	<ul style="list-style-type: none"> ■ The master unit's or slave unit's main control board is damaged. ■ The actual number of AHU Kits is different from the set number. ■ The address setting for the AHU kit is duplicated. ■ Communication between the master unit and slave unit fails. 	
Troubleshooting	 <pre> graph LR C72(C72) --> C1[Cause 1: The actual number of AHU Kits is different from the set number] C72 --> C2[Cause 2: The address setting for the AHU kit is duplicated.] C72 --> C3[Cause 3: The master unit's or slave unit's main control board is damaged] C72 --> C4[Cause 4: Communication between master unit and slave unit has failed] C1 --> S1[Set the number of AHU Kits based on the actual situation] C2 --> S2[Correct the address DIP switch] C3 --> S3[Replace the damaged main control board] C4 --> S4[Check the communication cables and take measures according to troubleshooting process for the error code "C71"] </pre>	

11.20 C76 - Abnormal communication between the main wired controller and secondary wired controller

Note: The error code C51 can be triggered either at the IDU side or at the wired controller side.

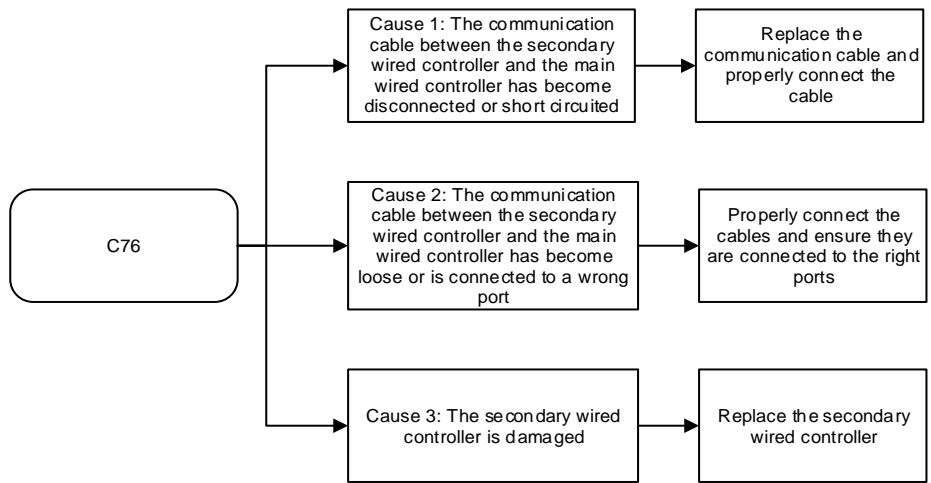
	Digital display	Display position
Error display		The error code "C76" is displayed only on the secondary wired controller
Error impact	The faulty IDU and other IDUs of the same system: operate normally. The wired controller does not work. ODU of the same system: operate normally.	
Error trigger	If the secondary wired controller has not received any reply from the main wired controller for 1 min	
Error recovery	Automatic recovery	
Possible cause	<ul style="list-style-type: none"> ■ The secondary wired controller is damaged. ■ Communication cables are loose or the communication port is faulty. ■ Communication cables have short-circuited or been cut off. 	
Troubleshooting		

11.21 C77, C78 - Abnormal communication between IDU main control board and 1# Expansion Board, abnormal communication between IDU main control board and 2# Expansion Board

Error display	Digital display		Display position
			Panel, display box, and wired controller
Error impact	Faulty IDU: The fan continues running, and the EEV is closed. Other IDUs of the same system: operate normally.		
	ODU of the same system: operate normally.		
Error trigger	If the main control board of an IDU has lost communication with 1# Expansion Board or 2# Expansion Board for 2 min		
Error recovery	Automatic recovery		
Possible cause	See the Troubleshooting section.		

Troubleshooting

Note: The main control board of the IDU cannot be directly connected to the Expansion Board. Instead, a Switch module has to be used. See Figure 1 below:

Figure 1 Wiring diagram of Expansion Board, Switch module, and IDU main control board

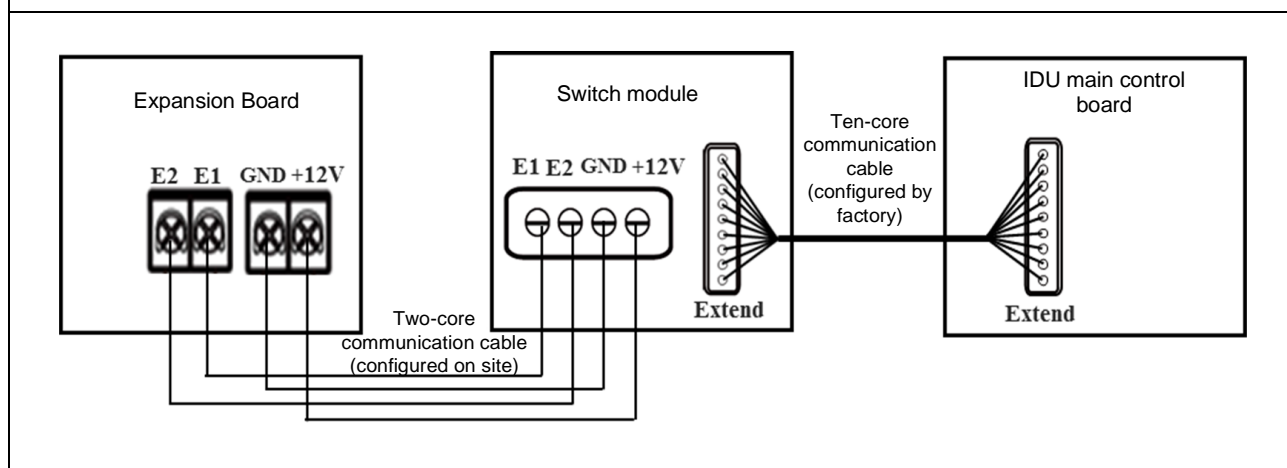

11.22 C79 - Abnormal communication between the IDU main control board and Switch module

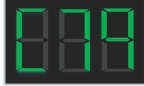
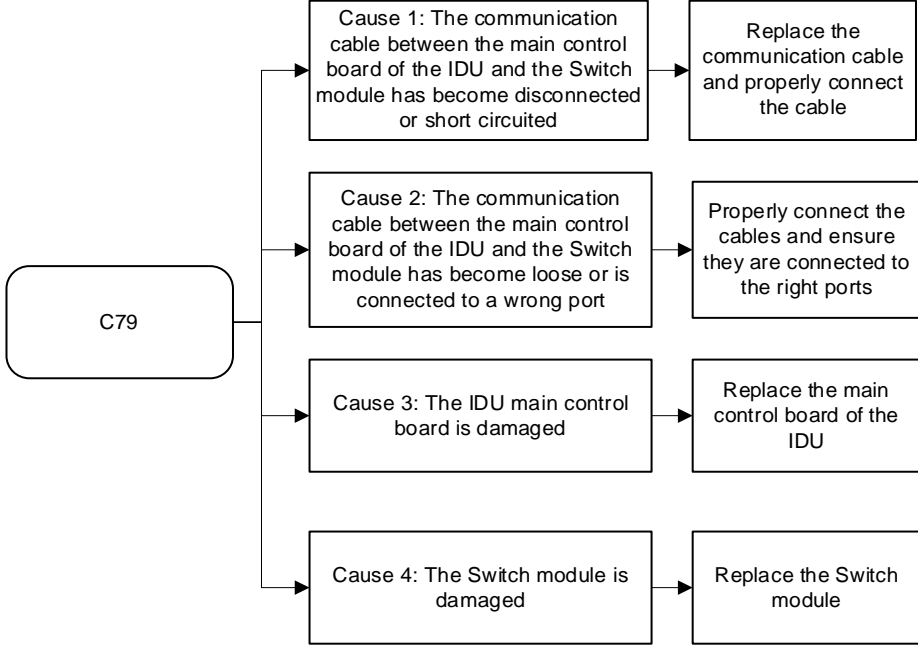
Error display	Digital display	Display position
		Panel, display box, and wired controller
Error impact	Faulty IDU: The fan continues running, and the EEV is closed. Other IDUs of the same system: operate normally. ODU of the same system: operate normally.	
Error trigger	If the main control board of an IDU has lost communication with the Switch module for 2 min	
Error recovery	Automatic recovery	
Possible cause	See the Troubleshooting section.	
Troubleshooting	 <pre> graph LR C79(C79) --> C1[Cause 1: The communication cable between the main control board of the IDU and the Switch module has become disconnected or short circuited] C79 --> C2[Cause 2: The communication cable between the main control board of the IDU and the Switch module has become loose or is connected to a wrong port] C79 --> C3[Cause 3: The IDU main control board is damaged] C79 --> C4[Cause 4: The Switch module is damaged] C1 --> A1[Replace the communication cable and properly connect the cable] C2 --> A2[Properly connect the cables and ensure they are connected to the right ports] C3 --> A3[Replace the main control board of the IDU] C4 --> A4[Replace the Switch module] </pre>	

11.23 d16 - Air inlet temperature of IDU is too low in heating mode

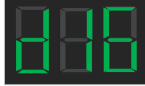
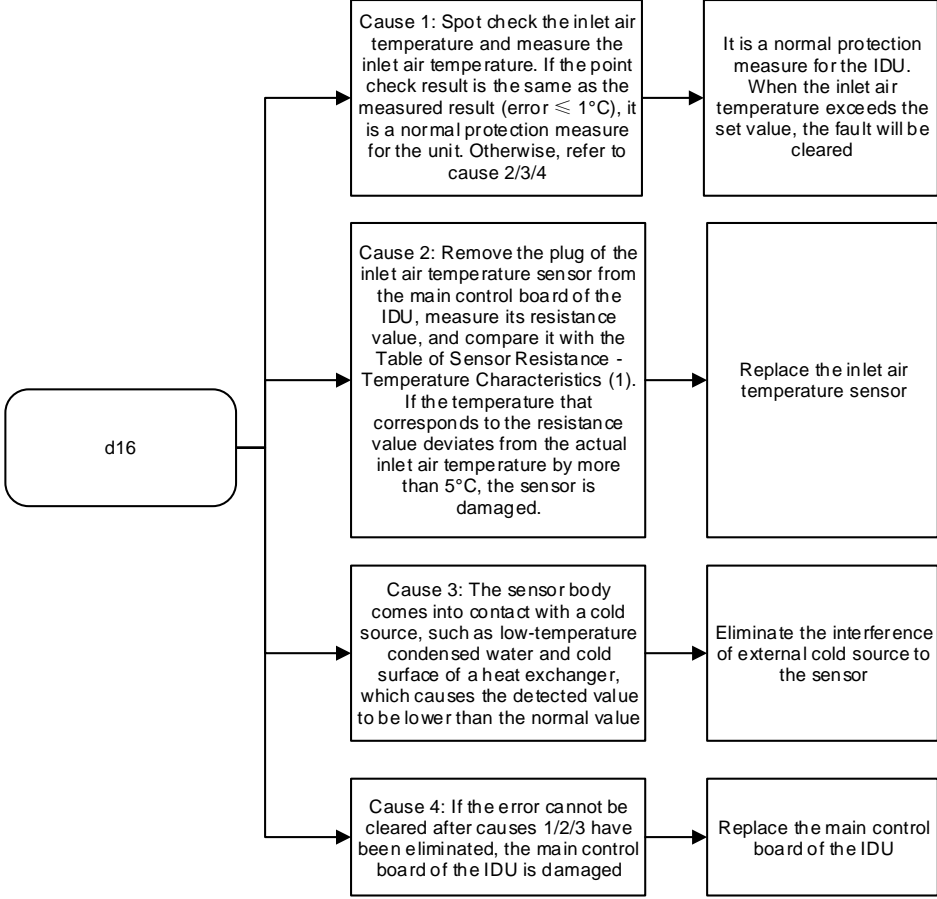
Error display	Digital display	Display position
		Panel, display box, and wired controller
Error impact	The faulty IDU stops. Other IDUs of the same system: operate normally.	
	ODU of the same system: operate normally.	
Error trigger	If the air inlet temperature of the IDU is lower than the set value (See the operating temperature range set out in the IDU Manual) for 5 min in heating mode	
Error recovery	Automatic recovery	
Possible cause	See the Troubleshooting section.	
Troubleshooting	 <pre> graph LR d16(d16) --> C1[Cause 1: Spot check the inlet air temperature and measure the inlet air temperature. If the point check result is the same as the measured result (error ≤ 1°C), it is a normal protection measure for the unit. Otherwise, refer to cause 2/3/4] d16 --> C2[Cause 2: Remove the plug of the inlet air temperature sensor from the main control board of the IDU, measure its resistance value, and compare it with the Table of Sensor Resistance - Temperature Characteristics (1). If the temperature that corresponds to the resistance value deviates from the actual inlet air temperature by more than 5°C, the sensor is damaged.] d16 --> C3[Cause 3: The sensor body comes into contact with a cold source, such as low-temperature condensed water and cold surface of a heat exchanger, which causes the detected value to be lower than the normal value] d16 --> C4[Cause 4: If the error cannot be cleared after causes 1/2/3 have been eliminated, the main control board of the IDU is damaged] C1 --> R1[It is a normal protection measure for the IDU. When the inlet air temperature exceeds the set value, the fault will be cleared] C2 --> R2[Replace the inlet air temperature sensor] C3 --> R3[Eliminate the interference of external cold source to the sensor] C4 --> R4[Replace the main control board of the IDU] </pre>	
	<p>Note:</p> <p>1. The inlet air temperature sensor is commonly found in the fresh air IDUs (The sensor code is defined as T0), and its resistance and temperature characteristics are similar to T1 - return air temperature sensor. Please refer to the Table of Temperature Sensor Resistance Characteristics listed in the Maintenance Manual to learn more about the sensor's features.</p>	

11.24 d17 - Air inlet temperature of IDU is too high in cooling mode

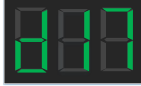
Error display	Digital display	Display position
		Panel, display box, and wired controller
Error impact	The faulty IDU stops. Other IDUs of the same system: operate normally.	
	ODU of the same system: operate normally.	
Error trigger	If the air inlet temperature of the IDU is higher than the set value (See the operating temperature range set out in the IDU Manual) for 5 min in cooling mode	
Error recovery	Automatic recovery	
Possible cause	See the Troubleshooting section.	

Troubleshooting

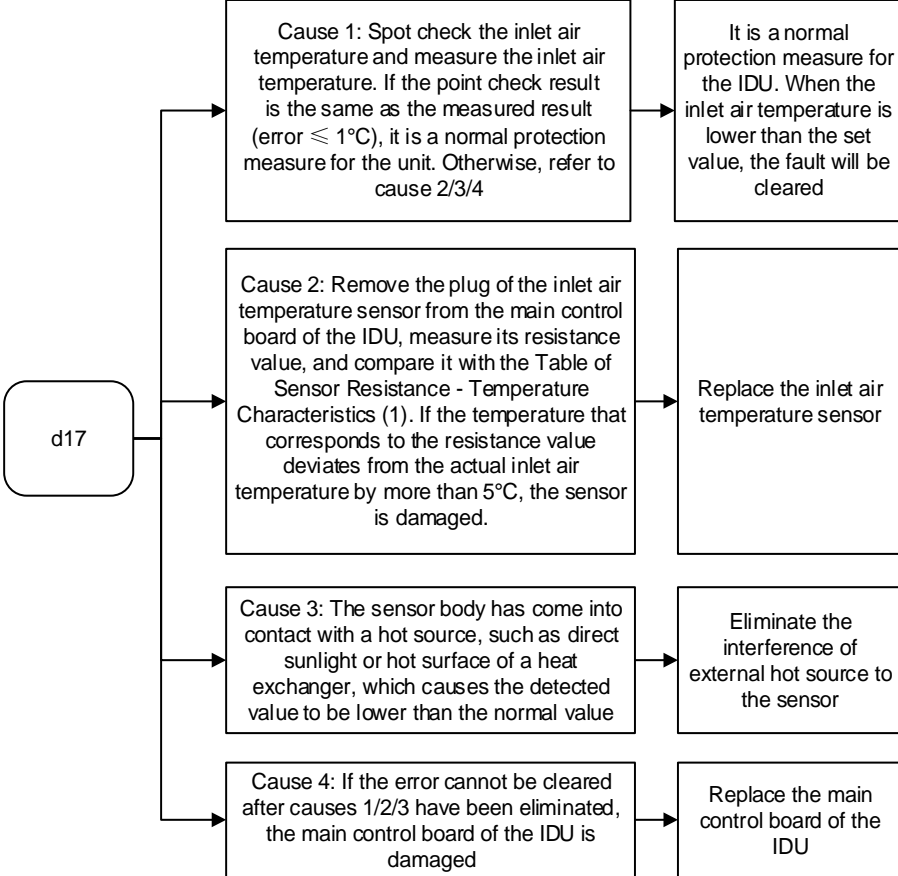

```

    graph LR
      d17((d17)) --> C1[Cause 1: Spot check the inlet air temperature and measure the inlet air temperature. If the point check result is the same as the measured result (error ≤ 1°C), it is a normal protection measure for the unit. Otherwise, refer to cause 2/3/4]
      d17 --> C2[Cause 2: Remove the plug of the inlet air temperature sensor from the main control board of the IDU, measure its resistance value, and compare it with the Table of Sensor Resistance - Temperature Characteristics (1). If the temperature that corresponds to the resistance value deviates from the actual inlet air temperature by more than 5°C, the sensor is damaged.]
      d17 --> C3[Cause 3: The sensor body has come into contact with a hot source, such as direct sunlight or hot surface of a heat exchanger, which causes the detected value to be lower than the normal value]
      d17 --> C4[Cause 4: If the error cannot be cleared after causes 1/2/3 have been eliminated, the main control board of the IDU is damaged]
      C1 --> R1[It is a normal protection measure for the IDU. When the inlet air temperature is lower than the set value, the fault will be cleared]
      C2 --> R2[Replace the inlet air temperature sensor]
      C3 --> R3[Eliminate the interference of external hot source to the sensor]
      C4 --> R4[Replace the main control board of the IDU]
  
```

Note:

1. The inlet air temperature sensor is commonly found in the fresh air IDUs (The sensor code is defined as T0), and its resistance and temperature characteristics are similar to T1 - return air temperature sensor. Please refer to the Table of Temperature Sensor Resistance Characteristics listed in the Maintenance Manual to learn more about the sensor's features.

11.25 E21, E24, E81 - T0 (fresh inlet air temperature sensor) short-circuits or cuts off, T1 (IDU return air temperature sensor) short-circuits or cuts off, and TA (outlet air temperature sensor) short-circuits or cuts off

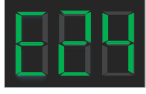
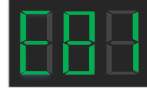
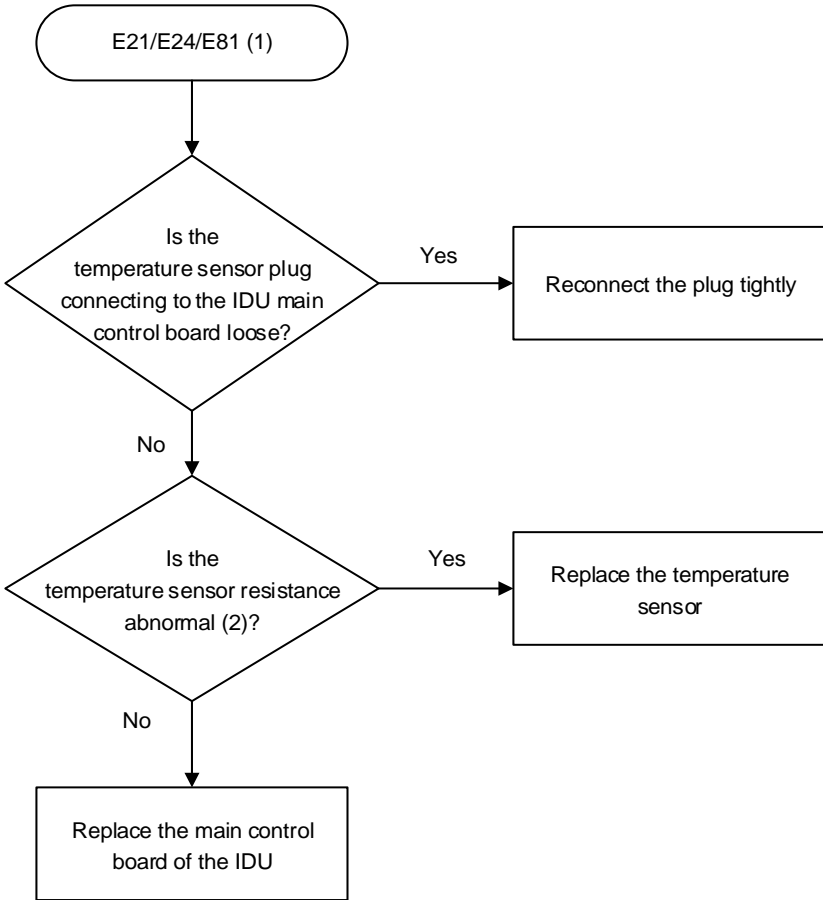
Error display	Digital display			Display position
				Panel, display box, and wired controller
Error impact	The faulty IDU stops. Other IDUs of the same system: operate normally.			
	ODU of the same system: operate normally.			
Error trigger	When detecting that the temperature sensor short-circuits or cuts off			
Error recovery	Automatic recovery			
Possible cause	<ul style="list-style-type: none"> ■ The temperature sensor is damaged. ■ The sensor plug to the T0/T1/TA port in the IDU main control board is loose. ■ The IDU main control board is damaged. 			
Troubleshooting	 <pre> graph TD Start([E21/E24/E81 (1)]) --> D1{Is the temperature sensor plug connecting to the IDU main control board loose?} D1 -- Yes --> A1[Reconnect the plug tightly] D1 -- No --> D2{Is the temperature sensor resistance abnormal (2)?} D2 -- Yes --> A2[Replace the temperature sensor] D2 -- No --> A3[Replace the main control board of the IDU] </pre>			
	<p>Note:</p> <p>1) The E21/E24/E81 code respectively corresponds to the T0/T1/TA temperature sensor. Check the wiring nameplate to find the sensor port on the main control board.</p> <p>2) Measure the resistance between two pins of the sensor plug with a multimeter. A resistance value close to 0 indicates a short circuit has occurred in the temperature sensor, and a resistance value close to infinity indicates an open circuit in the temperature sensor.</p> <p>3) When the AHU kit is set to return air temperature control, it is able to determine if the T1 sensor is short-circuited or open-circuited, but it is not able to determine if the T0 or TA sensors are short-circuited or open-circuited.</p> <p>When the AHU kit is set to supply air temperature control, it is able to determine if the T0 or TA sensors are short-circuited or open-circuited, but it is not able to determine if the T1 sensor is</p>			

short-circuited or open-circuited.

4) Only the master unit needs to be connected to the T1/T0/TA sensors when the AHU kit is installed in parallel.

11.26 EC1 - R32 refrigerant leakage sensor fault

Check the R32 refrigerant leakage sensor of faulty IDU

If the measured refrigerant saturation pressure at the liquid side or gas side is equal to the standard saturation pressure, there is no refrigerant leak. Then check whether the sensor is damaged or contaminated by foreign materials (such as steam and oil). If so, replace the sensor.

Error display	Digital display 	Display position Panel, display box, and wired controller
Error impact	Faulty IDU: stops. Other IDUs of the same system: operate normally. ODU of the same system: operate normally.	
Error trigger	When the IDU main control board receives sensor module fault signal from the R32 refrigerant detection device	
Error recovery	When the IDU main control board cannot detect a sensor module fault signal	
Possible cause	See the Troubleshooting section.	

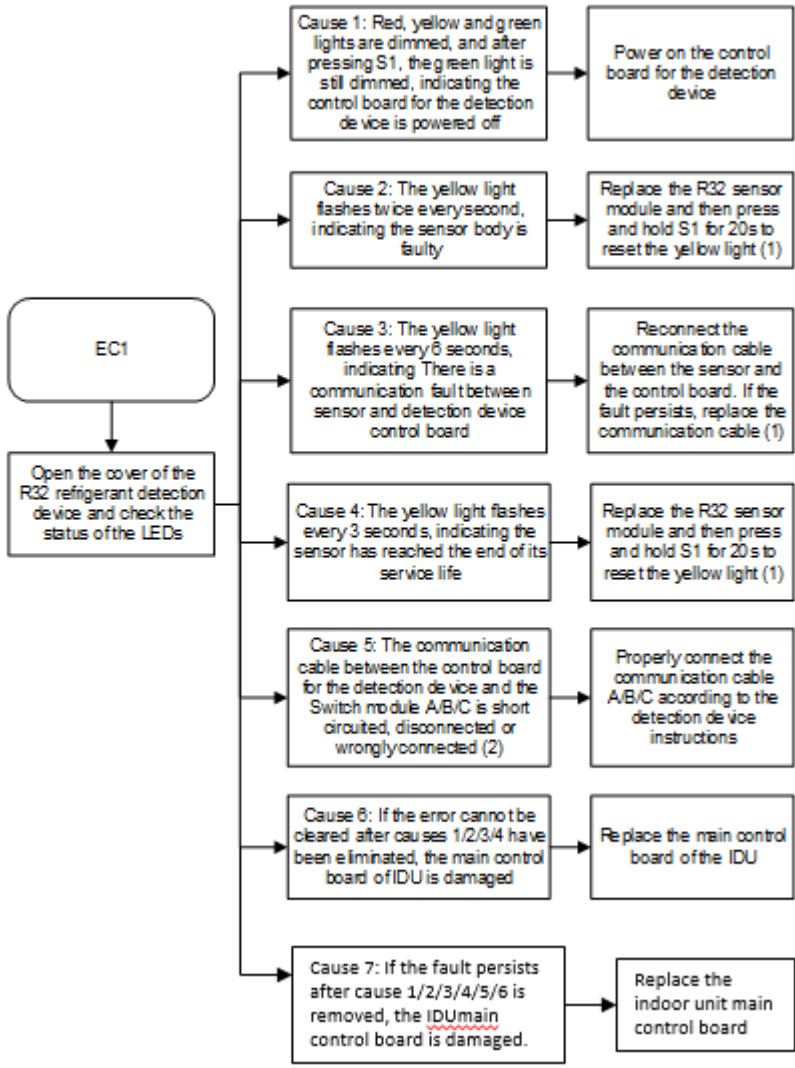
Troubleshooting		
	<p>Note:</p> <p>1. The three fault reset methods of sensor module failure, sensor module life expiration, and refrigerant detection device control board E fault: after maintenance, long press S1 key 10s on the control board to reset, when the reset is complete, all LED lights are steady for 2s and then off, and the R32 sensor life time recorded by EERPOM on the control board is cleared to zero; The sensor</p>	

module automatically resets when the sensor module communicates with the control board of the detection device.

2. The communication connection between the control board of the detection device and the adapter board A/B/D is shown in Figure 1.

Figure 1 Schematic diagram of the R32 refrigerant leakage detection system

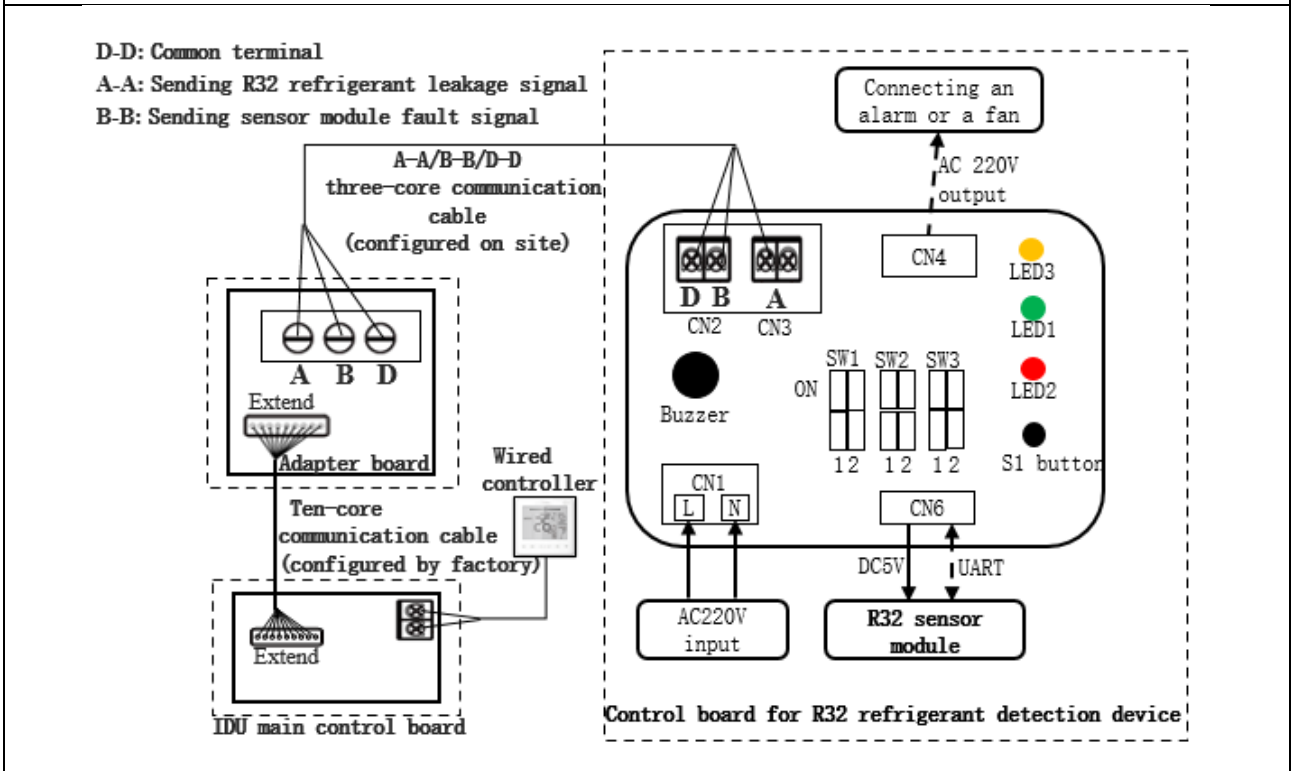

11.27 F01, F11 - T2A (heat exchanger liquid pipe temperature sensor) short-circuits or cuts off, T2 (heat exchanger middle temperature sensor) short-circuits or cuts off

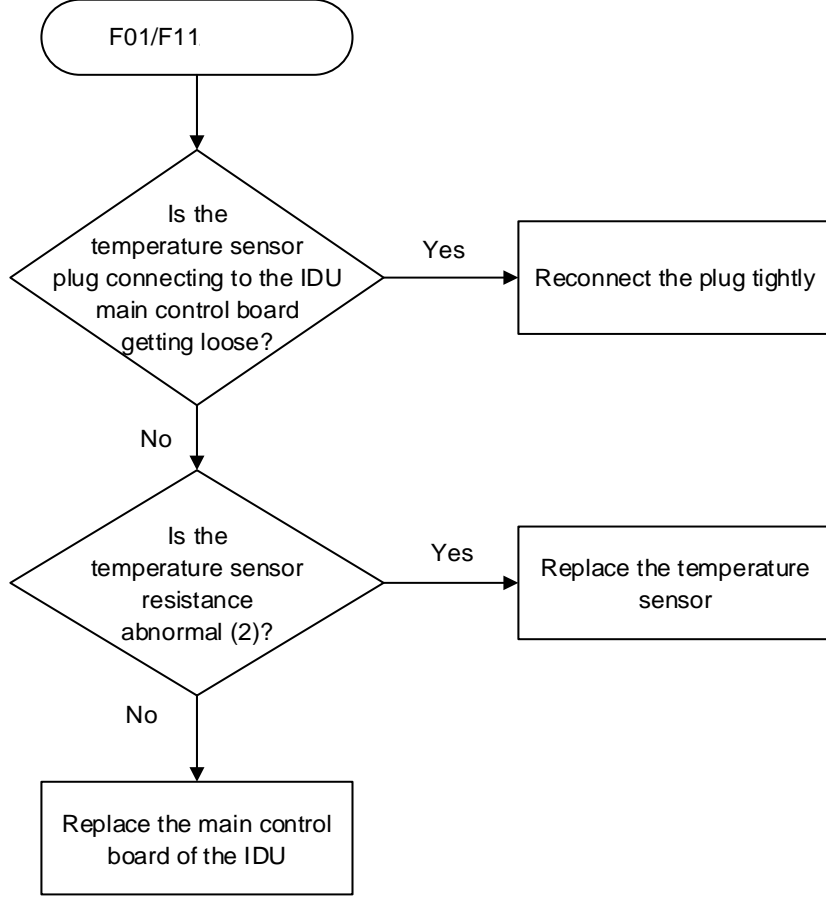
Error display	Digital display 	Display position Panel, display box, and wired controller
Error impact	The faulty IDU stops. Other IDUs of the same system: operate normally. ODU of the same system: operate normally.	
Error trigger	When detecting that the temperature sensor short-circuits or cuts off	
Error recovery	Automatic recovery	
Possible cause	<ul style="list-style-type: none"> ■ The temperature sensor is damaged. ■ The sensor plug connecting to the T2A/T2 port in the IDU main control board is loose. ■ The IDU main control board is damaged. 	
Troubleshooting	<div style="text-align: center;">  <pre> graph TD Start([F01/F11]) --> D1{Is the temperature sensor plug connecting to the IDU main control board getting loose?} D1 -- Yes --> A1[Reconnect the plug tightly] D1 -- No --> D2{Is the temperature sensor resistance abnormal (2)?} D2 -- Yes --> A2[Replace the temperature sensor] D2 -- No --> A3[Replace the main control board of the IDU] </pre> </div> <p>Note:</p> <ol style="list-style-type: none"> 1) The F01/F11 codes respectively correspond to T2A/T2 temperature sensors. Check the wiring nameplate to find the sensor port on the main control board. 2) Measure the resistance between two pins of the sensor plug with a multimeter. A resistance value close to 0 indicates a short circuit has occurred in the temperature sensor, and a resistance value close to infinity indicates an open circuit in the temperature sensor. 3) If only the master unit is connected to the T2A/T2 temperature sensors in the parallel control of the AHU kit, then only the master unit can detect the F01/F11 faults, and the slave units cannot detect them. 	

11.28 P71 - Main control board EEPROM fault

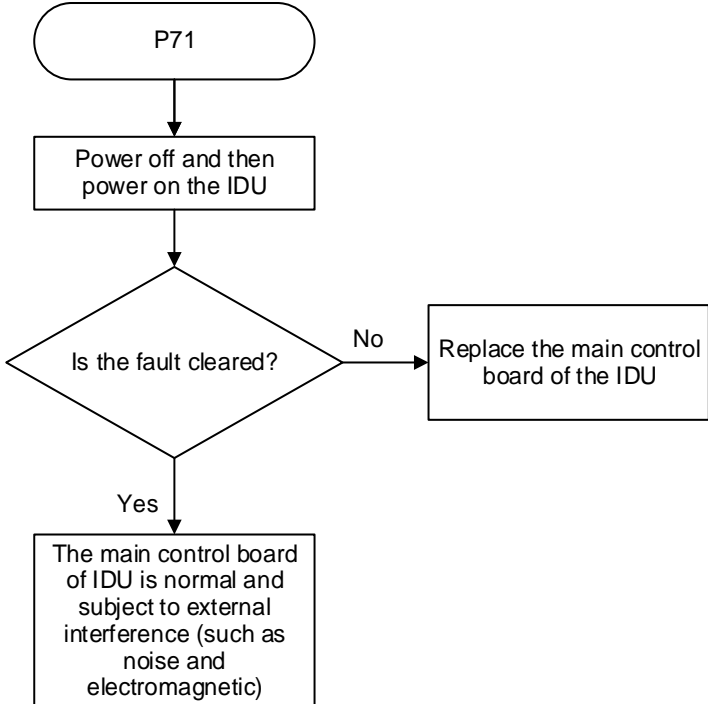
Error display	Digital display	Display position
		Panel, display box, and wired controller
Error impact	The faulty IDU stops. Other IDUs of the same system: operate normally.	
	ODU of the same system: operate normally.	
Error trigger	When the master chip cannot receive data from EEPROM (EEPROM: a non-volatile memory whose data are kept even when powered off)	
Error recovery	Automatic recovery	
Possible cause	<ul style="list-style-type: none"> ■ The IDU main control board is damaged. ■ External interference (such as noise and electromagnetic) 	
Troubleshooting	 <pre> graph TD Start([P71]) --> Step[Power off and then power on the IDU] Step --> Decision{Is the fault cleared?} Decision -- No --> Action[Replace the main control board of the IDU] Decision -- Yes --> End[The main control board of IDU is normal and subject to external interference (such as noise and electromagnetic)] </pre>	

11.29 P72 - IDU display control board EEPROM fault

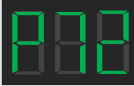
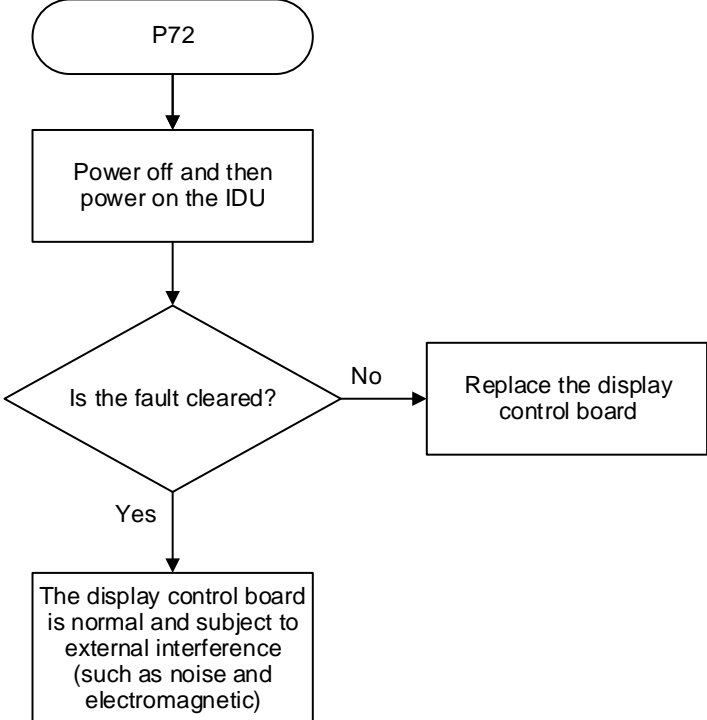
Error display	Digital display	Display position
		Panel or display box
Error impact	The faulty IDU operates normally, and the error code is displayed on the panel or display box only. Other IDUs of the same system: operate normally.	
	ODU of the same system: operate normally.	
Error trigger	Unable to read data from display control board EEPROM (EEPROM: a non-volatile memory whose data are kept even when powered off)	
Error recovery	Automatic recovery	
Possible cause	<ul style="list-style-type: none"> ■ The display control board is damaged. ■ External interference (such as noise and electromagnetic) 	
Troubleshooting	 <pre> graph TD Start([P72]) --> Step[Power off and then power on the IDU] Step --> Decision{Is the fault cleared?} Decision -- No --> Action[Replace the display control board] Decision -- Yes --> Note[The display control board is normal and subject to external interference (such as noise and electromagnetic)] </pre>	

11.30 U11 - Unit model code not set

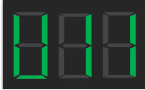
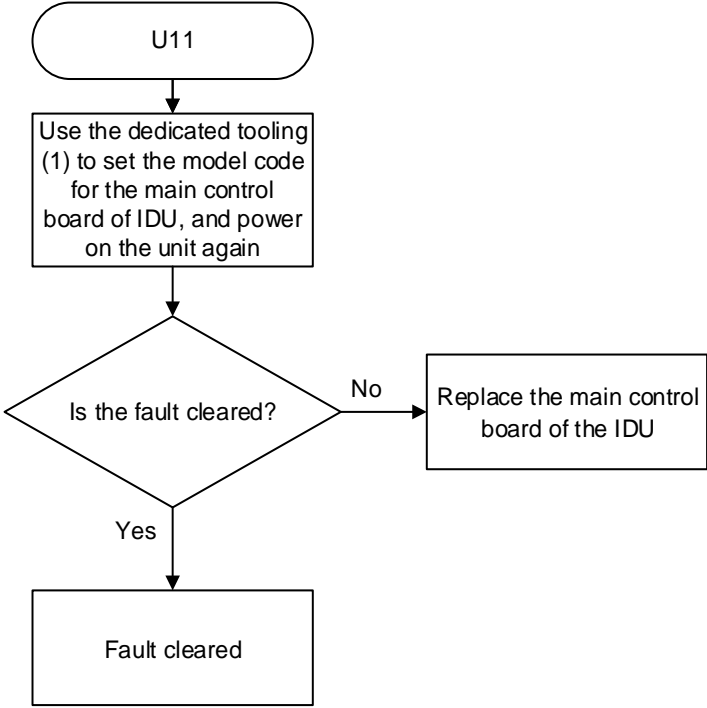
Error display	Digital display	Display position
		Panel, display box, and wired controller
Error impact	<p>1) The faulty IDU stops running.</p> <p>2) Other IDUs of the same system:</p> <ul style="list-style-type: none"> ■ If the address for the faulty IDU has been set, other IDUs will operate normally. ■ If the address of the faulty IDU was not set, other IDUs will display error code "A51"-ODU fault. (The indoor unit of V6 platform displays "Ed" code) 	
	<p>ODU of the same system:</p> <ul style="list-style-type: none"> ■ If the address for the faulty IDU has been set, the ODU will operate normally. ■ If the address of the faulty IDU was not set, the ODU will display the error code "C26" -number of IDUs reduced. (The outdoor unit of V6 platform displays "H7" code.) 	
Error trigger	When detecting that the unit model code for IDU main control board is not set	
Error recovery	Automatic recovery	
Possible cause	<ul style="list-style-type: none"> ■ The unit model code has not been set after replacing the IDU main control board. ■ The IDU main control board is damaged. 	
Troubleshooting	 <pre> graph TD Start([U11]) --> Step[Use the dedicated tooling (1) to set the model code for the main control board of IDU, and power on the unit again] Step --> Decision{Is the fault cleared?} Decision -- Yes --> End([Fault cleared]) Decision -- No --> Action[Replace the main control board of the IDU] </pre>	
	<p>Note 1: For specialized tooling and instructions, please contact your local dealer or technical support personnel.</p>	

11.31 U12 - Capacity(HP) code not set

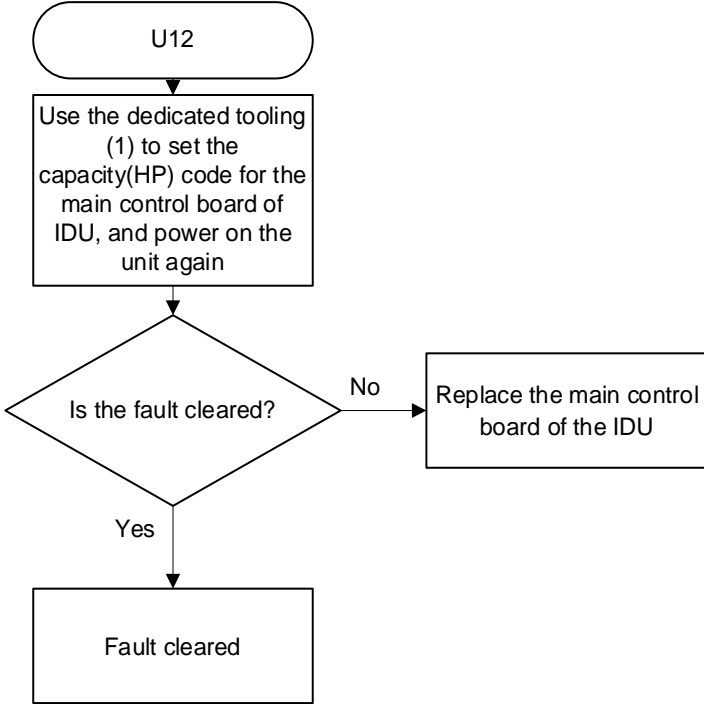
Error display	Digital display	Display position
		Panel, display box, and wired controller
Error impact	<p>1) The faulty IDU stops running.</p> <p>2) Other IDUs of the same system:</p> <ul style="list-style-type: none"> ■ If the address for the faulty IDU has been set, other IDUs will operate normally. ■ If the address of the faulty IDU was not set, other IDUs will display error code "A51"-ODU fault. <p>ODU of the same system:</p> <ul style="list-style-type: none"> ■ If the address for the faulty IDU has been set, the ODU will operate normally. ■ If the address of the faulty IDU was not set, the ODU will display the error code "C26" -number of IDUs reduced. 	
Error trigger	When detecting that the capacity(HP) code for IDU main control board has not been set	
Error recovery	Automatic recovery	
Possible cause	<ul style="list-style-type: none"> ■ The capacity(HP) code has not been set after replacing the IDU main control board. ■ The new IDU main control board is damaged. 	
Troubleshooting	<div style="text-align: center;">  <pre> graph TD Start([U12]) --> Step[Use the dedicated tooling (1) to set the capacity(HP) code for the main control board of IDU, and power on the unit again] Step --> Decision{Is the fault cleared?} Decision -- Yes --> End([Fault cleared]) Decision -- No --> Action[Replace the main control board of the IDU] </pre> </div> <p>Note 1: For specialized tooling and instructions, please contact your local dealer or technical support personnel.</p>	

11.32 U14 - The capacity value of the AHU Kit DIP switch does not match the model

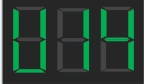
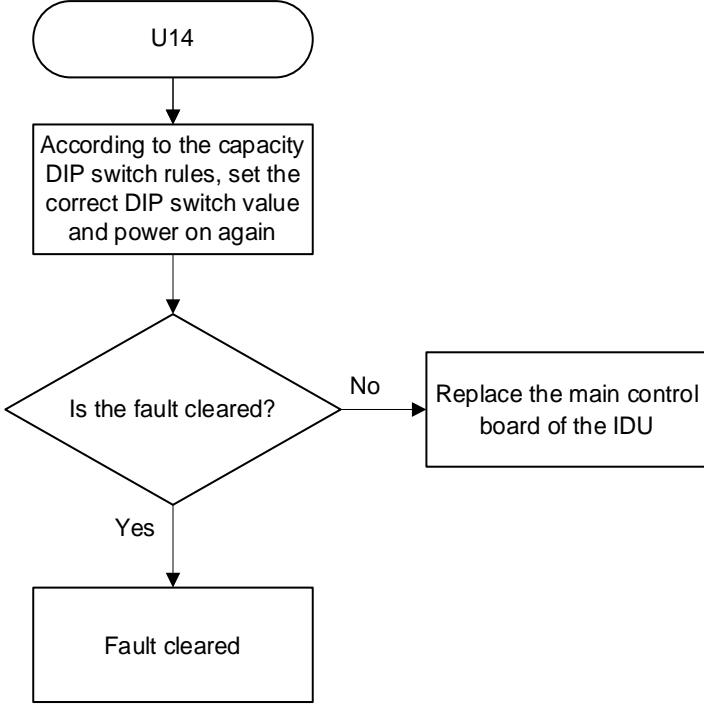
Error display	Digital display	Display position
		Panel, display box, and wired controller
Error impact	1) The faulty IDU stops running. 2) Other IDUs of the same system: operate normally	
	ODU of the same system: operate normally	
Error trigger	The capacity value of the AHU Kit DIP switch is not within the capability segment corresponding to the current model	
Error recovery	After setting the capacity value of the AHU Kit DIP switch correctly, power on again	
Possible cause	<ul style="list-style-type: none"> ■ The capacity value of the AHU Kit DIP switch is not within the capability segment corresponding to the current model ■ The IDU main control board is damaged. 	
Troubleshooting	<div style="text-align: center;">  <pre> graph TD Start([U14]) --> Process[According to the capacity DIP switch rules, set the correct DIP switch value and power on again] Process --> Decision{Is the fault cleared?} Decision -- Yes --> End[Fault cleared] Decision -- No --> Action[Replace the main control board of the IDU] </pre> </div>	



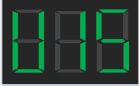
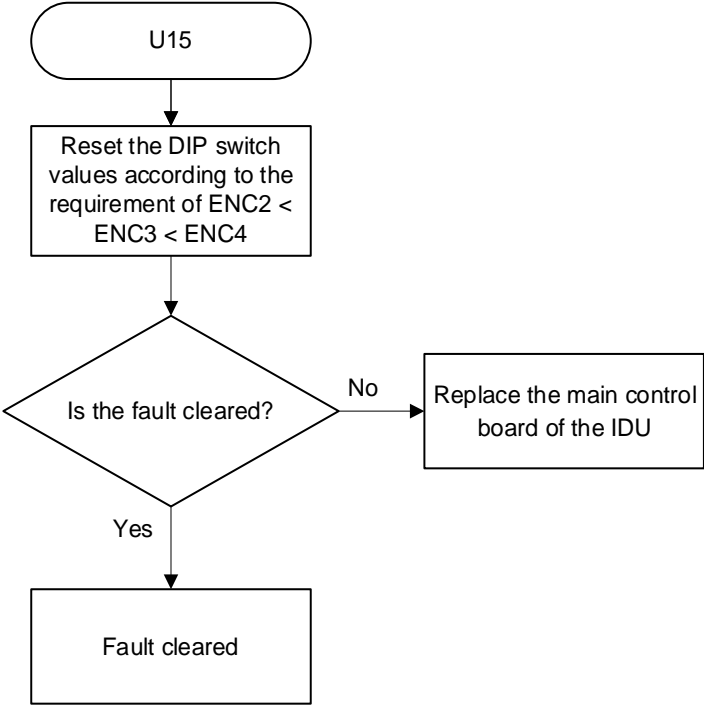

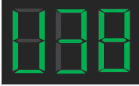
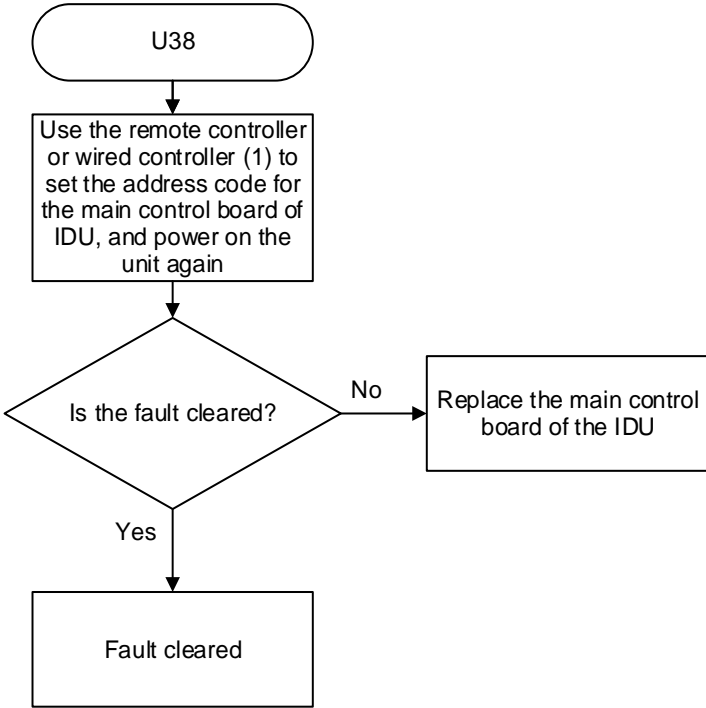

11.33 U15 - The DIP value of AHU Kit's fan speed output voltage is incorrect

Error display	Digital display	Display position
		Panel, display box, and wired controller
Error impact	1) The faulty IDU stops running. 2) Other IDUs of the same system: operate normally	
	ODU of the same system: operate normally	
Error trigger	The voltage values corresponding to the high/medium/low speed of the AHU kit do not meet the condition: The voltage corresponding to the high fan speed > The voltage corresponding to the medium fan speed > The voltage corresponding to the medium low speed	
Error recovery	Automatic recovery	
Possible cause	■ The DIP switch values of ENC2/ENC3/ENC4 do not meet the requirement that ENC2 < ENC3 < ENC4 (Note: The DIP switches of ENC2, ENC3, and ENC4 on the main control board correspond to the output voltage values of the low speed, medium speed, and high speed, respectively).	
	■ The IDU main control board is damaged.	
Troubleshooting	 <pre> graph TD Start([U15]) --> Process1[Reset the DIP switch values according to the requirement of ENC2 < ENC3 < ENC4] Process1 --> Decision{Is the fault cleared?} Decision -- Yes --> Process2[Fault cleared] Decision -- No --> Process3[Replace the main control board of the IDU] </pre>	

11.34 U38 - Address code not detected

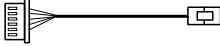
Error display	Digital display	Display position
		Panel, display box, and wired controller
Error impact	1) The faulty IDU stops running. 2) Other IDUs of the same system: The fan continues running, the EEV is closed, and ODU error code "A51" is displayed (V6 platform IDU displays the code "Ed"). ODU of the same system: Otherwise, the ODU will display the error code "C26" (number of IDUs reduced) (V6 platform ODU displays the code "H7")	
Error trigger	When detecting that the address code for IDU main control board has not been set	
Error recovery	Automatic recovery	
Possible cause	<ul style="list-style-type: none"> ■ The address code has not been set after replacing the IDU main control board. ■ The new IDU main control board is damaged. 	
Troubleshooting	<div style="text-align: center;">  <pre> graph TD Start([U38]) --> Step[Use the remote controller or wired controller (1) to set the address code for the main control board of IDU, and power on the unit again] Step --> Decision{Is the fault cleared?} Decision -- No --> Action[Replace the main control board of the IDU] Decision -- Yes --> End[Fault cleared] </pre> </div> <p>Note 1: For instructions on how to set up addresses for a remote controller or a wired controller, please refer to relevant manuals.</p>	

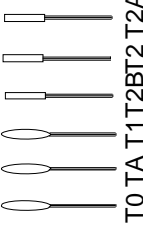
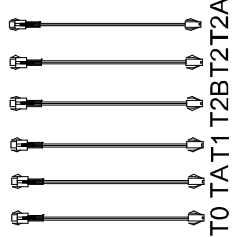
12 Accessories

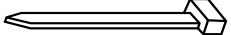
Name	Shape	Quantity	Function
Installation & Owner's Manual		1	-
Wired controller		1	Wired controller
Electronic Expansion valve extension cable		1	-
Fixed clamp of temperature sensor		3	-
Sleeve		3	-
Temperature sensors		6	-
Temperature sensors extension cables		6	-
Screw ST 3.9x25		4	Secure the installation board
Plastic expanded tube		4	-
Cable Tie		6	-

13 Appendix

13.1 Temperature Sensor Resistance Characteristics

Table 13.1: Indoor ambient temperature sensor, indoor heat exchanger mid-point temperature sensor and indoor heat exchanger outlet

Temperature (°C)	Resistance (kΩ)	Temperature (°C)	Resistance (kΩ)	Temperature (°C)	Resistance (kΩ)	Temperature (°C)	Resistance (kΩ)
-20	106.193	20	12.621	60	2.355	100	0.620
-19	100.028	21	12.041	61	2.269	101	0.602
-18	94.259	22	11.490	62	2.187	102	0.584
-17	88.857	23	10.967	63	2.109	103	0.567
-16	83.796	24	10.471	64	2.033	104	0.551
-15	79.054	25	10.000	65	1.961	105	0.535
-14	74.607	26	9.553	66	1.892	106	0.520
-13	70.436	27	9.128	67	1.825	107	0.505
-12	66.521	28	8.725	68	1.761	108	0.490
-11	62.847	29	8.342	69	1.700	109	0.477
-10	59.396	30	7.977	70	1.641	110	0.463
-9	56.153	31	7.631	71	1.585	111	0.450
-8	53.106	32	7.302	72	1.530	112	0.438
-7	50.241	33	6.988	73	1.478	113	0.425
-6	47.546	34	6.690	74	1.428	114	0.414
-5	45.010	35	6.407	75	1.380	115	0.402
-4	42.623	36	6.137	76	1.334	116	0.391
-3	40.376	37	5.880	77	1.289	117	0.381
-2	38.259	38	5.635	78	1.247	118	0.370
-1	36.264	39	5.402	79	1.206	119	0.361
0	34.385	40	5.179	80	1.166	120	0.351
1	32.613	41	4.968	81	1.128	121	0.342
2	30.941	42	4.766	82	1.091	122	0.332
3	29.364	43	4.573	83	1.056	123	0.324
4	27.876	44	4.390	84	1.022	124	0.315
5	26.471	45	4.215	85	0.990	125	0.307
6	25.145	46	4.047	86	0.958	126	0.299
7	23.892	47	3.888	87	0.928	127	0.291
8	22.708	48	3.736	88	0.899	128	0.284
9	21.590	49	3.590	89	0.870	129	0.277
10	20.532	50	3.451	90	0.843	130	0.269
11	19.532	51	3.318	91	0.817	131	0.263
12	18.586	52	3.192	92	0.792	132	0.256
13	17.690	53	3.070	93	0.768	133	0.250
14	16.843	54	2.954	94	0.744	134	0.243
15	16.041	55	2.843	95	0.722	135	0.237
16	15.281	56	2.737	96	0.700	136	0.231
17	14.562	57	2.635	97	0.679	137	0.226
18	13.880	58	2.538	98	0.659	138	0.220
19	13.234	59	2.444	99	0.639	139	0.215

NOTE CONCERNING PROTECTION OF ENVIRONMENT



This product must not be disposed of via normal household waste after its service life, but must be taken to a collection station for the recycling of electrical and electronic devices. The symbol on the product, the operating instructions or the packaging indicate such disposal procedures. The materials are recyclable in accordance with their respective symbols. By means of re-use, material recycling or any other form of recycling old appliances you are making an important contribution to the protection of our environment. Please ask your local council where your nearest disposal station is located.

INFORMATION CONCERNING USED REFRIGERANT MEDIUM

This unit is containing fluorinated gases included in the Kyoto protocol.
The maintenance and the liquidation must be carried out by qualified personnel.

Type of refrigerant: R32/R410a

The composition of the cooling medium R32: (100% HFC-32)

The composition of the cooling medium R410a: (50% HFC-32, 50% HFC-125)

The quantity of the refrigerant: Please see the unit label.

The value GWP of R32: 675 (1 kg R32 = 0,675 t CO₂ eq)

The value GWP of R410a: 2088 (1kg R410a=2,088t CO₂ eq)

GWP = Global Warming Potential

NOTE: Indoor unit can use R32 and R410a, it depends on outdoor unit.



Appliance filled with flammable gas R32.

In case of quality problem or other please contact your local supplier or authorized service center.

Emergency number: 112

PRODUCER

SINCLAIR CORPORATION Ltd.
16 Great Queen Street
WC2B 5AH London
United Kingdom
www.sinclair-world.com

This product was manufactured in China (Made in China).

REPRESENTATIVE

SINCLAIR Global Group s.r.o.
Purkynova 45
612 00 Brno
Czech Republic

TECHNICAL SUPPORT

SINCLAIR Global Group s.r.o.
Purkynova 45
612 00 Brno
Czech Republic
Tel.: +420 800 100 285 | Fax: +420 541 590 124
www.sinclair-solutions.com | info@sinclair-solutions.com

