

SERVICE MANUAL

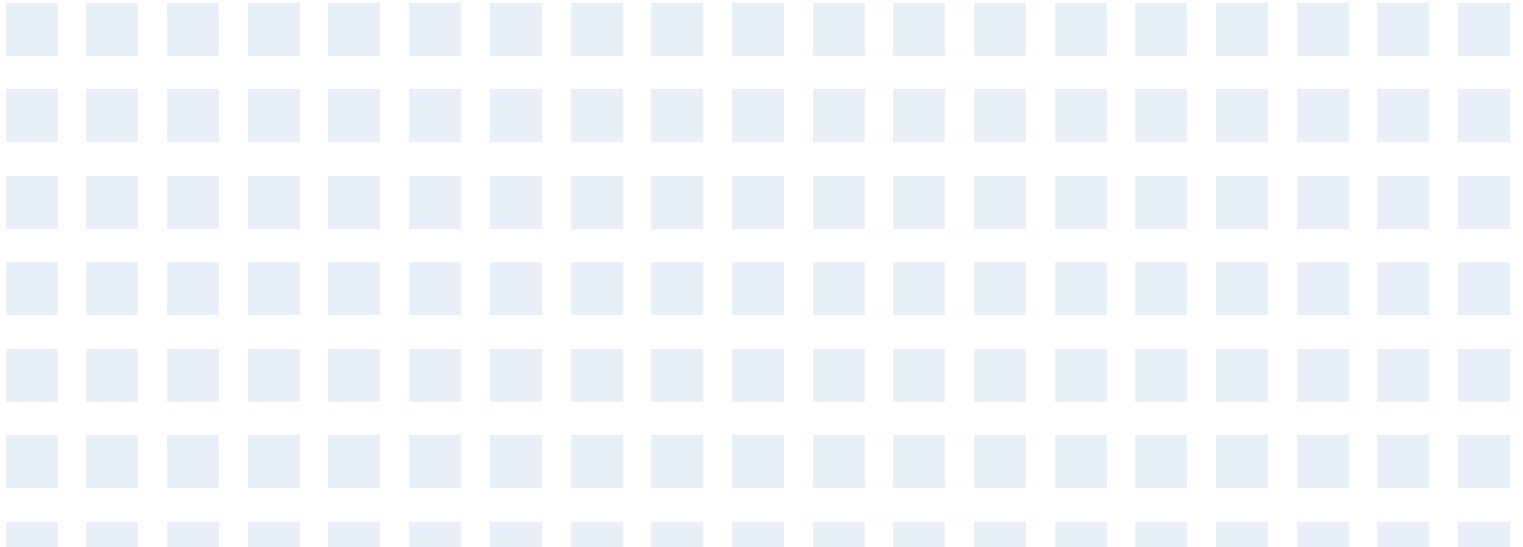

IMPORTANT NOTE:

Read this manual carefully before installing or operating your new heat pump.
Make sure to save this manual for future reference.

Contents

PART 1 GENERAL INFORMATION.....	2
1. MEASUREMENTS.....	2
2. EXTERNAL APPEARANCE.....	2
3. NOMENCLATURE	3
PART 2 PERFORMANCE	4
1. FEATURES	4
2. REFRIGERANT CIRCUIT	5
3. UNIT STRUCTURE	6
4. SPECIFICATIONS.....	7
5. DIMENSION (UNIT: MM).....	10
6. PERFORMANCE DIAGRAM	12
7. WIRING DIAGRAM	17
8. INSTALLATION.....	19
9. USE.....	30
9.1 CHECKING LIST BEFORE TRIAL- RUNNING:	30
9.2. INITIAL STARTUP	30
10. MAINTENANCE	33
11. TROUBLE SHOOTING.....	35
12. FUNCTION.....	49
13. OPERATION.....	53
14. ACCESSORIES.....	59
15. RESISTANCE CHARACTERISTIC OF TEMPERATURE SENSOR	1

Part 1 General information

1. Measurements

Model	Net/Gross weight (kg)	Dimension (mm, W x D x H)	Power Supply
SWH-190PS	94/115	560×595×1730	220-240V~, 50Hz, 1Ph
SWH-300PS	132/160	600×695×1895	

2. External appearance



SWH-190PS



SWH-300PS

3. Nomenclature

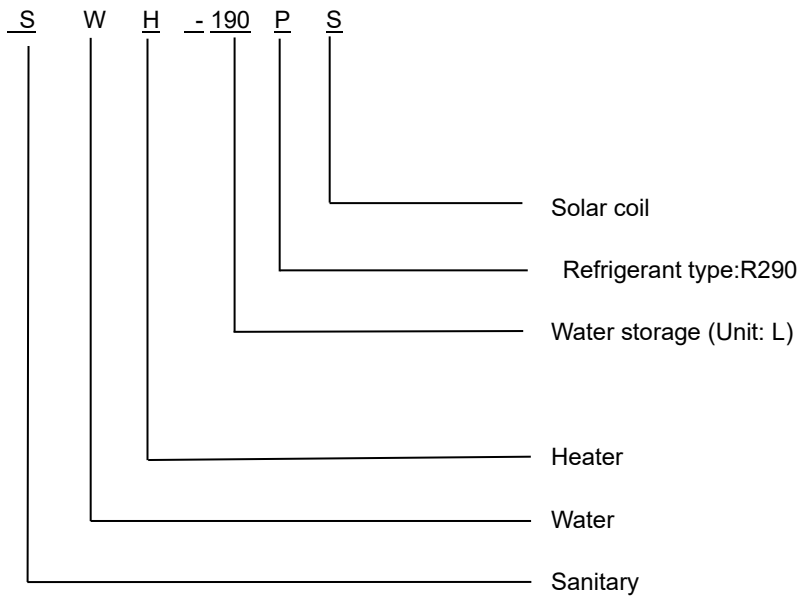

Part 2 Performance

1. Features

- ◇ Microchannel heat transfer technology
 1. Design of multi-loop flat channels reduce condensation pressure
 2. Enhanced surface with parallel flow design effectively increases heat transfer efficiency
 3. High-strength design, endured 9 MPa pressure
 4. High performance heat-conductive paste significantly improves heat transfer efficiency

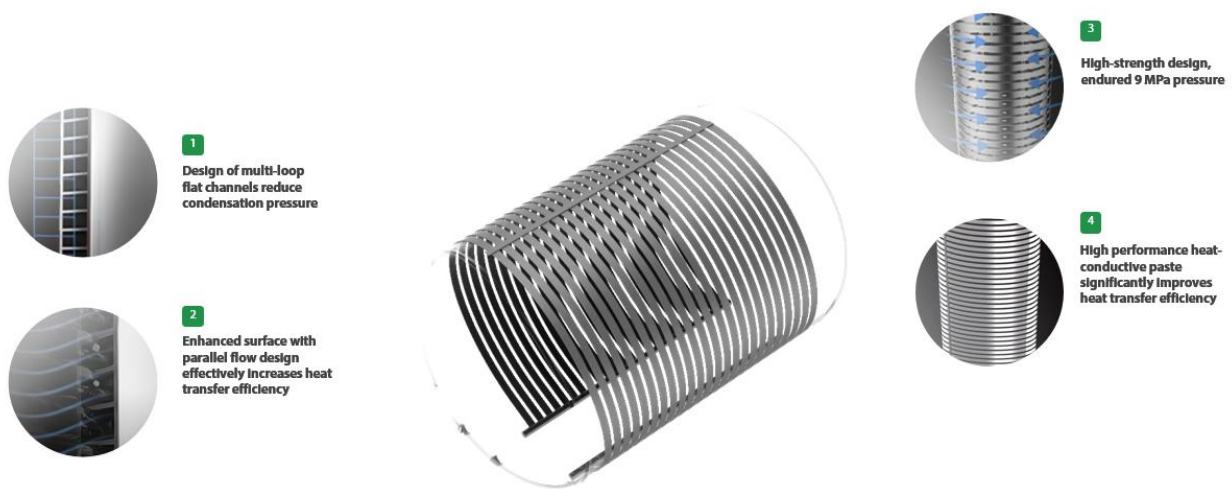

- ◇ The maximum outlet water temperature: 70°C. The system makes the water be heated stably and quickly with innovative heating methods of combination the electric heating and heat pump heating properly.
- ◇ Automatic startup and shutdown, automatic defrosting by revising refrigerant cycle to save the extra operation.
- ◇ According to the heat pump principle, the unit absorbs heat from outdoor air and produce heat water; thermal efficiency can be up to 3.25(Under the condition 16147).
- ◇ CE, LVD, RED, key mark, ERP& NF certification.
- ◇ Within the temperature range from -20 °C to 46 °C, the unit will not be affected by night, cloudy sky, rain even snow weather.

2. Refrigerant circuit

SWH-190PS, SWH-300PS

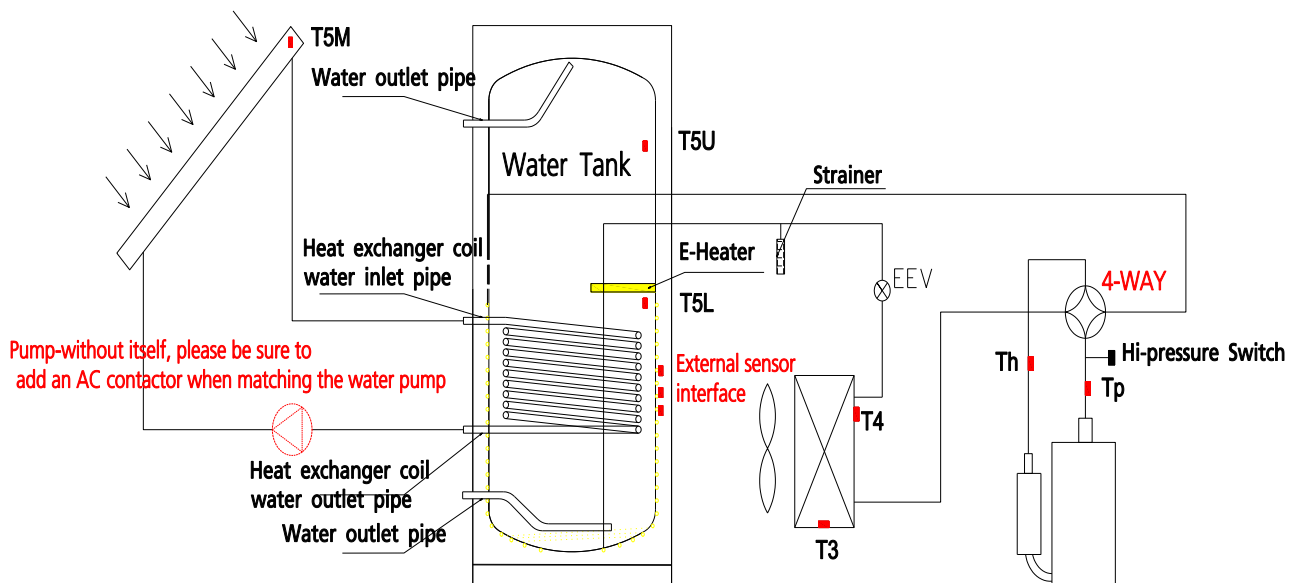

NOTE: It is recommended to add a thermostat.

Compressor: RDSN89V11TZL (190L) & RDSN108V11TBZ (300L), R290 high efficiency compressor, supplied by GMCC.

Evaporator: copper tube and aluminum fin type heat exchanger.

EEV: electronic expansion valve, the opening is regulated according to the discharge air temperature of compressor.

Fan: centrifugal fan. The motor is supplied by Welling or Green-Intelligence.

TCO (Temperature Switch): The power of compressor and E-heater will be automatically shut-of or turn on by TCO. If the water temperature is higher than 85°C, the TCO will automatically shut of the power of compressor and E-heater. After that it needs to be reset manually.

3. Unit structure

The head's structure

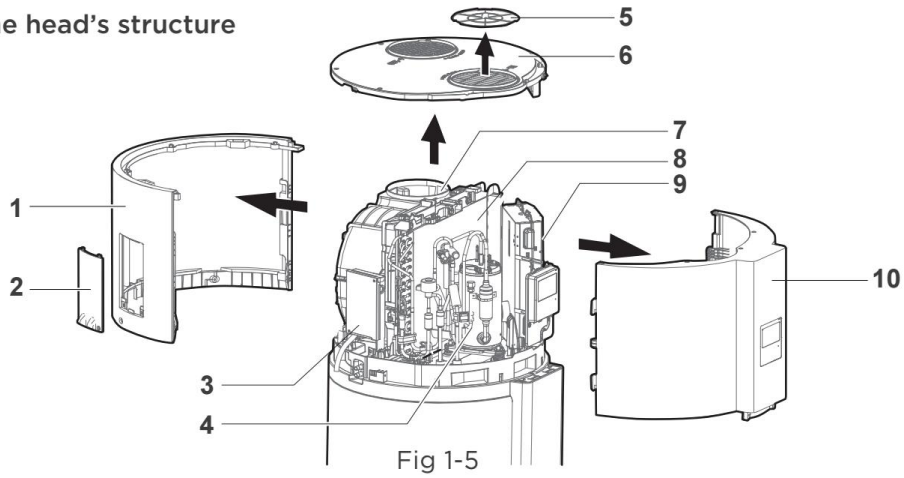

- | | |
|-----------------------|---------------------------|
| 1. rear cover | 6. top cover |
| 2. junction box cover | 7. fan assy |
| 3. junction box | 8. evaporator |
| 4. compressor | 9. electronic control box |
| 5. filter | 10. front cover |

SWH-190PS

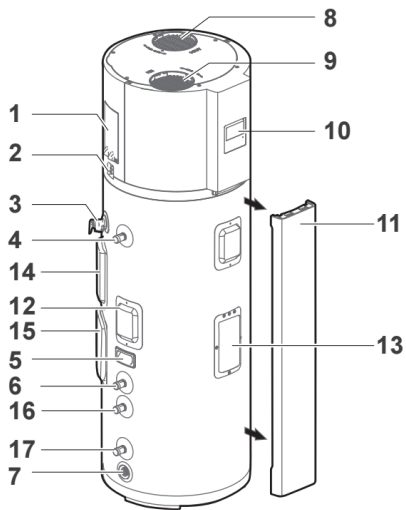

1. Junction box
2. condensate drain
3. PTR valve
4. water outlet
5. handle
6. water inlet
7. drain outlet
8. air outlet
9. air inlet
10. display

SWH-300PS

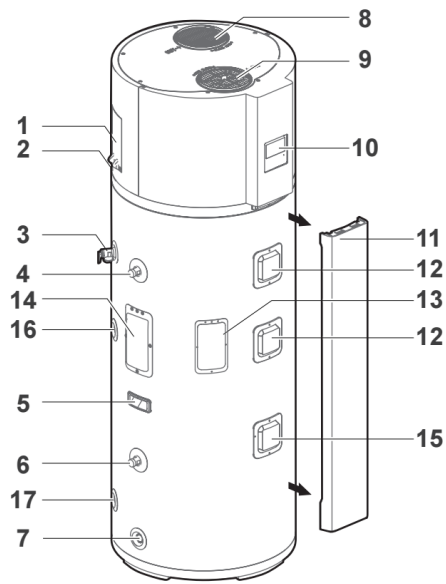

11. front decorative board
12. magnesium rod
13. TCO + Temperature sensor fixation
14. Impressed current anode (optional)
15. electrical heater
16. solar/boiler inlet
17. solar/boiler outlet

4. Specifications

Model			SWH-190PS	SWH-300PS
Power supply		Ph-V-Hz	1-220~240-50	1-220~240-50
Running ambient temp.	Heat pump	°C	-7~43	-7~43
	E-heater		-20~46	-20~46
Storage size		Ltr	181 L	270L
Maximum inlet water pressure		Mpa	0.7	0.7
Net/gross weight		kg	94/115	132/160
Dimension (D×H)		mm	560×595×1730	660×695×1895
Packing (W×H×D)		mm	655×675×1945	745×775×2110
MAX.Hot water temperature with heat pump		°C	65	65
MAX.Hot water temperature additional electric heater		°C	70	70
Tank	Material	-	Enameled steel	Enameled steel
	Cathodic protection	-	Mg rod anode	Mg rod anode
	Insulating type	-	Polyurethane	Polyurethane
	Insulation thickness	mm	42	42
	Water inlet pipe	mm	DN20	DN20
	Water outlet pipe	mm	DN20	DN20
	Drainage pipe	mm	DN20	DN20
	Max. operating pressure (safety valve)	MPa	0.85	0.85
Electrical data (Heat pump+ electric heater)	Maximum heat pump power input	W	600	710
	E-heater	W	1640	1640
	Maximum power input	W	2240	2350
	Maximum current input	A	10.5	11.0
Refrigerant design pressure		MPa	3.0/1.2	2.7/1.1
Air circuit	Fan type	-	Centrifugal	Centrifugal
	Ari volume flow rate	m³/h	350	450
	Rated external static max pressure	Pa	30	30
	Available external static max pressure (Modified via engineering mode)	Pa	80	80
	Ducts diameter	mm	160	190
Refrigerant circuit	Compressor	-	Rotary	Rotary
	Refrigerant	-	R290	R290
	Refrigerant charge	g	150	150

	Evaporator	-	Copper-aluminum finned coil	Copper-aluminum finned coil
	Condenser	-	Aluminum tube wound outside tank	Aluminum tube wound outside tank
Solar coil	Material	-	SUS316L	SUS316L
	Surface	m ²	0.6	1.1
	Max pressure	MPa	1.0	1.0
Data according to EN 16147: 2017 standard for AVERAGE climate (unit in ECO mode, Hot water setpoint = 54 ° C; Inlet water = 10 ° C; Inlet air temp = 7 ° C DB / 6 ° C WB) * according to European regulation 812/2013	Load profile	-	L	XL
	Water heating energy efficiency class	-	A+	A+
	Water heating energy efficiency - η	%	130	128
	COP _{DHW}	-	3.14	3.13
	Maximum volume of mixed water at 40°C-V ₄₀	L	245	345
	Reference hot water temperature- θ_{wh}	°C	53	53
	RaTBD heat output -PraTBD	kWh	1.10	1.33
	Heating up time-t _h	hh:m m	07:47	09:02
	Annual electricity consumption-AEC	kWh/a	785	1312
Stand-by power input (P _{es})	W	26	22	
Data according to EN 12102-2: 2019 ECO mode with Inlet air temp = 7 ° C DB / 6 ° C WB	Indoor sound power level (without duct)	dB(A)	51	51
Loading Quantity	20'/40'/40H	Pcs	24/54/54	21/45/45
Throttling type			Electric expansion valve	Electric expansion valve
System protection			Over-load Protector, Temp Controller & Protector, Electric Protector, etc.	Over-load Protector, Temp Controller & Protector, Electric Protector, etc.
Air flow		m ³ /h	350	450
Compressor	Model		RDSN89V11TZL	RDSN108V11TBZ
	Type		Rotary	Rotary
	Brand		GMCC	GMCC
	Capacity	W	1710	2150
	Input	W	415	518
	RaTBD current(RLA)	A	1.88	2.42
	Locked rotor Amp(LRA)	A	10	14

	Thermal protector	/	URP-267-78 HPA-315	URP-267-78 HPA-315
	Capacitor	/	15 μ F/450V	20 μ F/450V
	Refrigerant oil	ml	XS-601C1 / 140ml	PAG VG60 / 170ml
Evaporator coil	Number of rows	/	2	2
	Tube pitch(a)x row pitch(b)	mm	18 \times 17.3	18 \times 17.3
	Fin spacing	mm	1.3	1.3
	Fin type (code)	/	Hydrophilic aluminum	Hydrophilic aluminum
	Tube outside dia. and type	mm	Φ 5 Inner groove copper tube	Φ 5 Inner groove copper tube
	Coil length x height	mm	376 \times 324	480 \times 324
	Number of circuits	/	2	3
Fan motor	Model	/	ZKFP-34-10-1	ZKFP-34-10-1
	Brand	/	welling/Green Intelligence	welling/ Green Intelligence
	Input	w	15	15
	Speed	r/min	650	650

Notes:

1. The test conditions: outdoor temp. 15/12 °C(DB/WB), inlet water temp = 15°C, outlet water temp = 45°C.
2. Data according to EN 12102-2: ECO mode with inlet and outlet air ducts at 30 Pa.
3. Data according to EN 16147: 2017 standard for AVERAGE climate (unit in ECO mode, Hot water setpoint = 53 °C; Inlet water = 10°C ; Inlet air temp = 7° C DB / 6°C WB) * according to European regulation 812/2013.

5. Dimension (Unit: mm)

Connector	spec.
hot water outlet	R3/4"
cold water inlet	R3/4"
PTR valve	RC3/4"
drain pipe	NPT3/4"
Solar outlet	R3/4"
Solar inlet	R3/4"

SWH-190PS

SWH-190PS

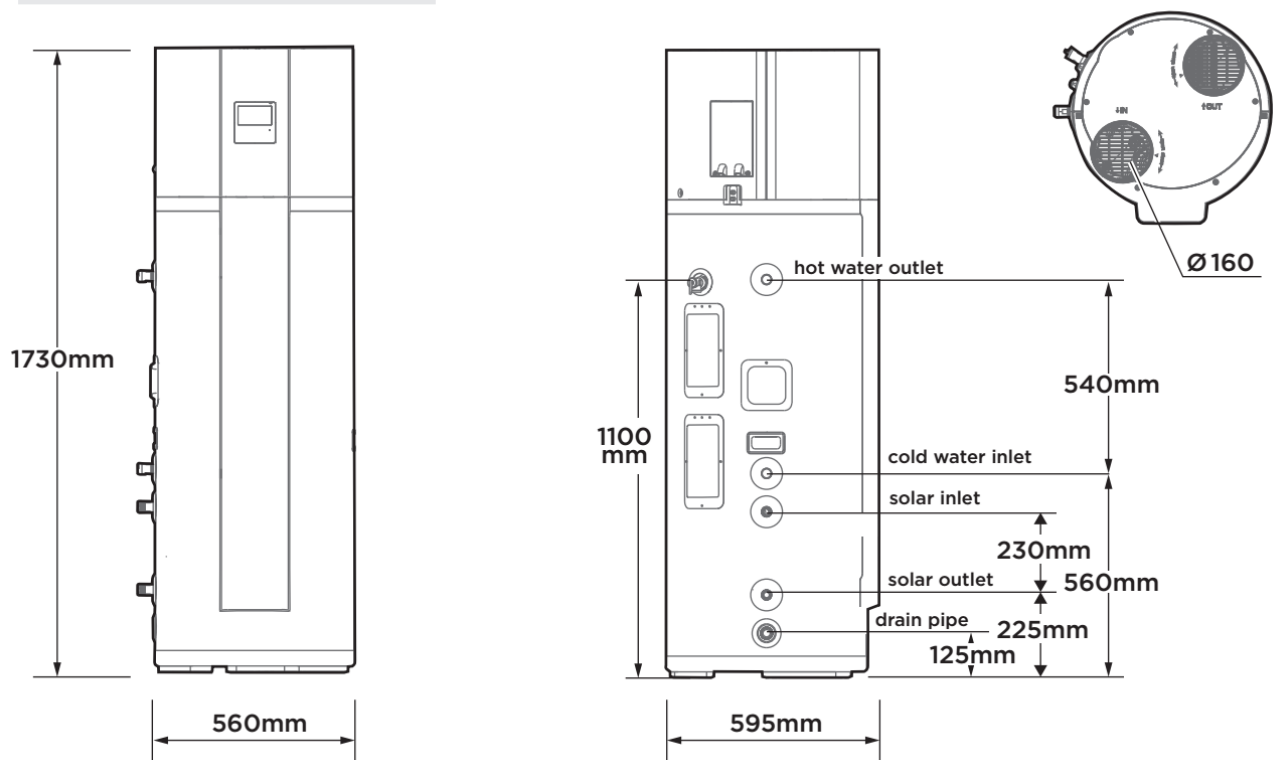

SWH-300PS

SWH-300PS

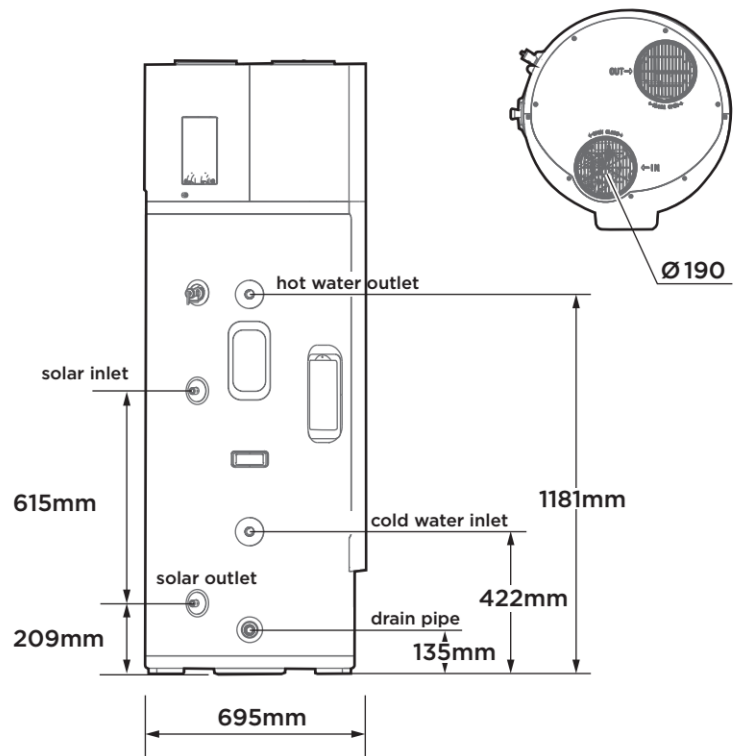
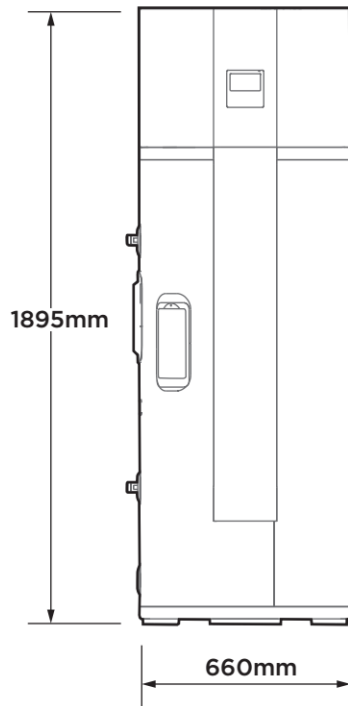

6. Performance diagram

Heat source will be automatically selected by unit. But manually E-Heater operation is available.

Operation range

Setting water temperature target range: 38~70°C.

Min. temperature of room of installation		0°C
Max. temperature of room of installation		43°C
Minimum air inlet temperature(a)	Heat pump	-7°C
	E-heater	-20°C
Maximum air inlet temperature(a)	Heat pump	43°C
	E-heater	46°C

Water temperature limits

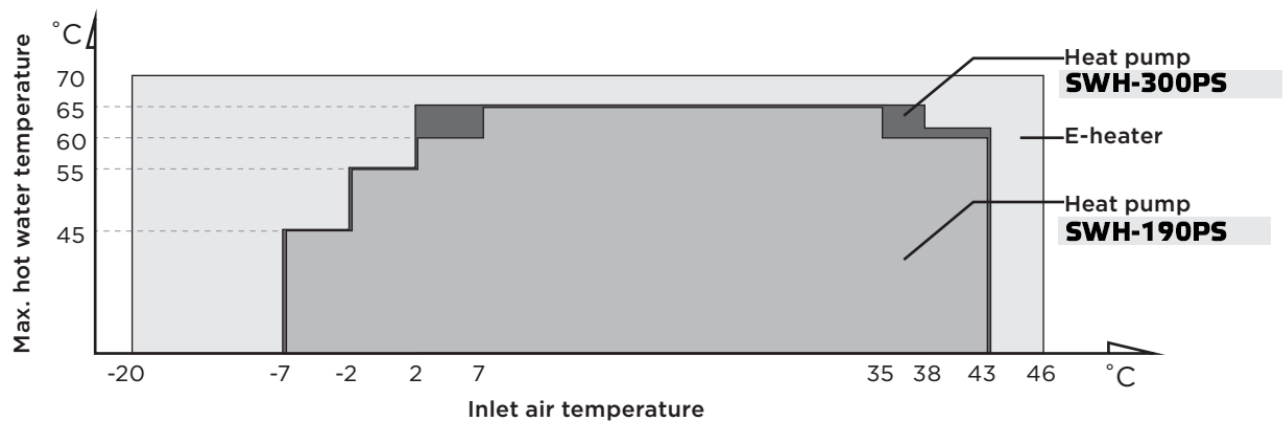

Heat-up Time

There are different heat-up times in different ambient temperature. Lower inlet air temperature result longer heat-up time because of lower effective performance.

When air temp below 2°C, heat pump and E-heater will take different portions of heating capacity, generally the lower of inlet air temperature, the lower portion of heat pump will be taken as well as the higher portion of E-heater will account for.

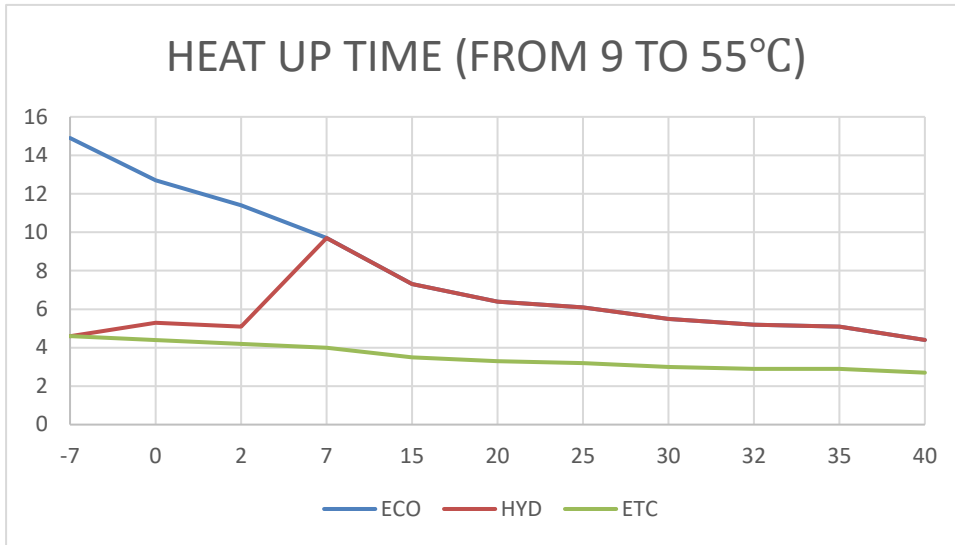

(The test conditions: inlet water at 9 °C, and setting temperature at 55 °C)

T4	-7	0	2	7	15	20	25	30	32	35	40
ECO	14.9	12.7	11.4	9.7	7.3	6.4	6.1	5.5	5.2	5.1	4.4
HYD	4.6	5.3	5.1	9.7	7.3	6.4	6.1	5.5	5.2	5.1	4.4
ETC	4.6	4.4	4.2	4.0	3.5	3.3	3.2	3.0	2.9	2.9	2.7

The curve between heat up time and ambient temperature

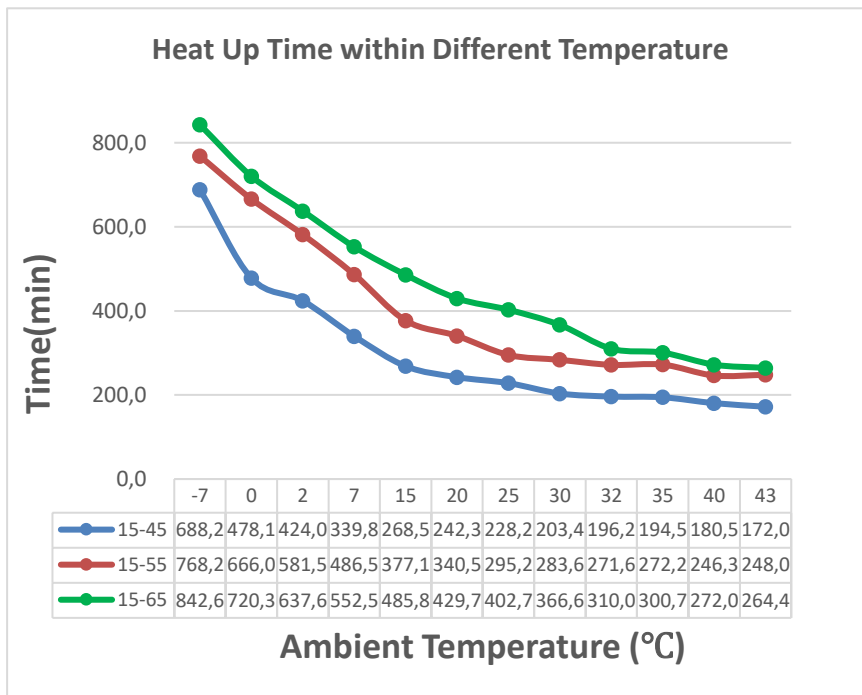

The curve between capacity and ambient temperature

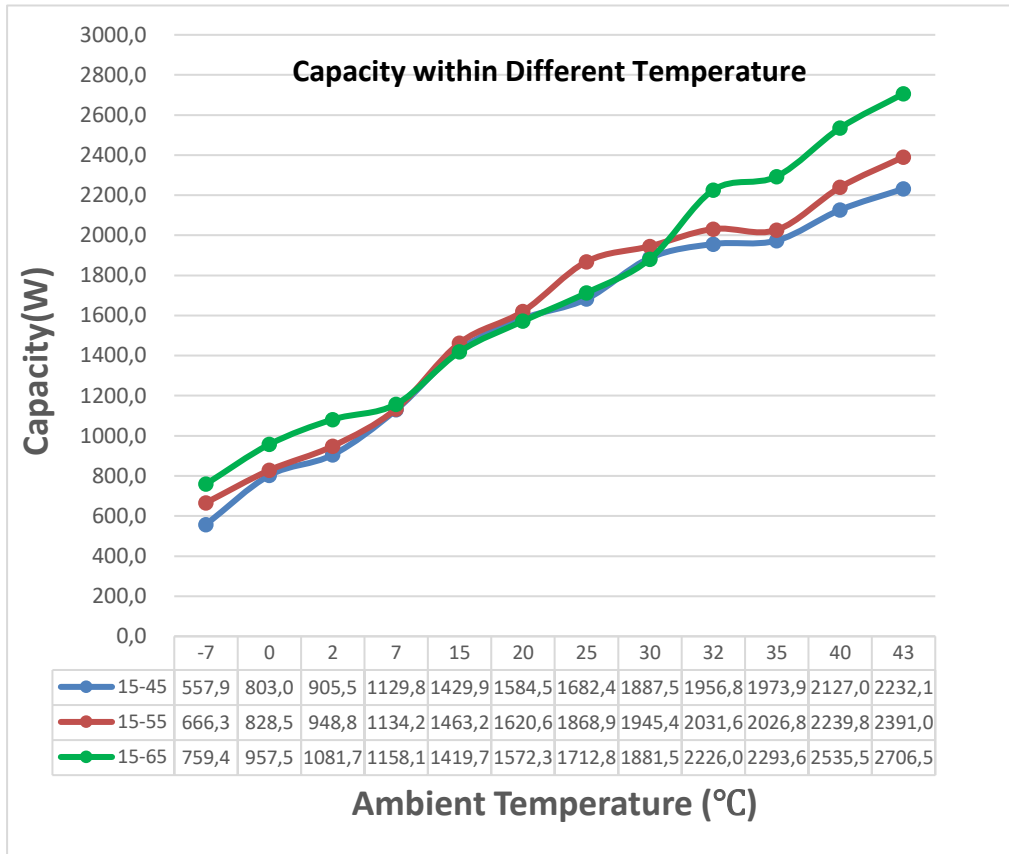

The curve between COP and ambient temperature

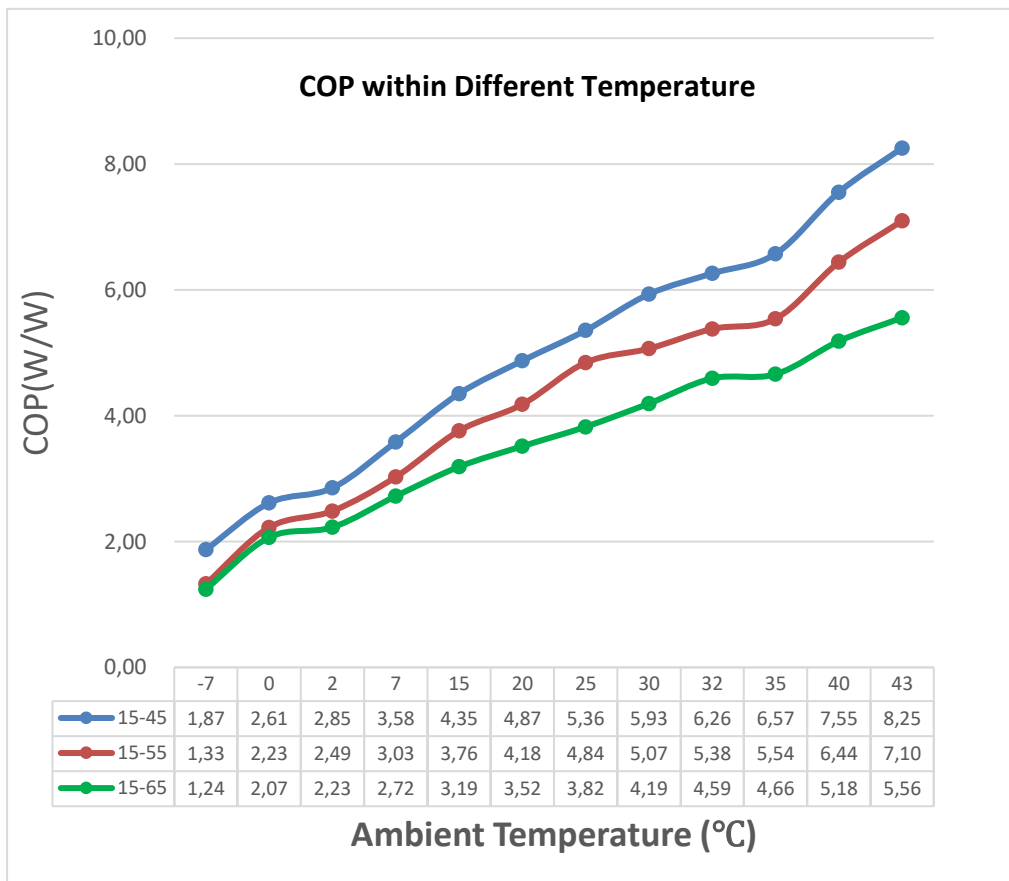

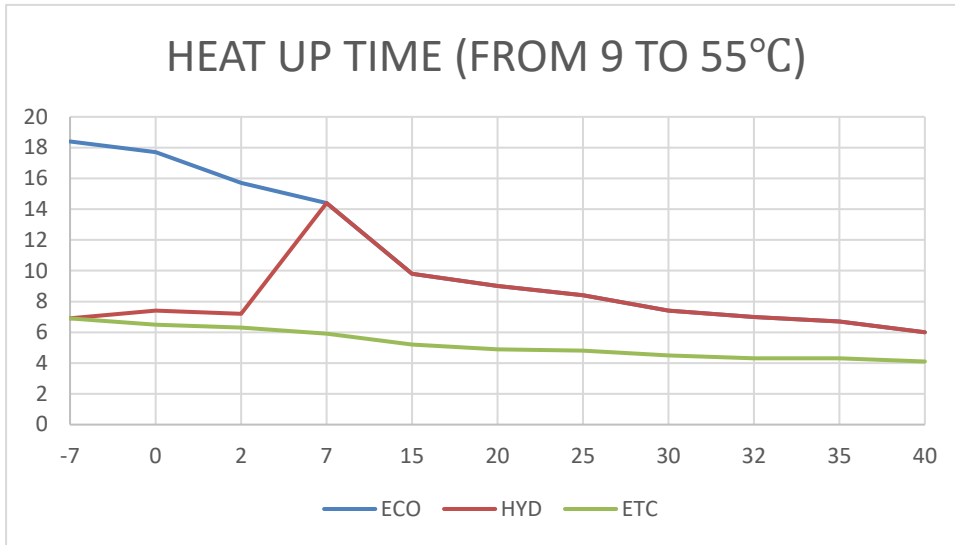

(The test conditions: inlet water at 9 °C, and setting temperature at 55 °C)

T4	-7	0	2	7	15	20	25	30	32	35	40
ECO	18.4	17.7	15.7	14.4	9.8	9	8.4	7.4	7	6.7	6
HYD	6.9	7.4	7.2	14.4	9.8	9	8.4	7.4	7	6.7	6
ETC	6.9	6.5	6.3	5.9	5.2	4.9	4.8	4.5	4.3	4.3	4.1

The curve between heat up time and ambient temperature

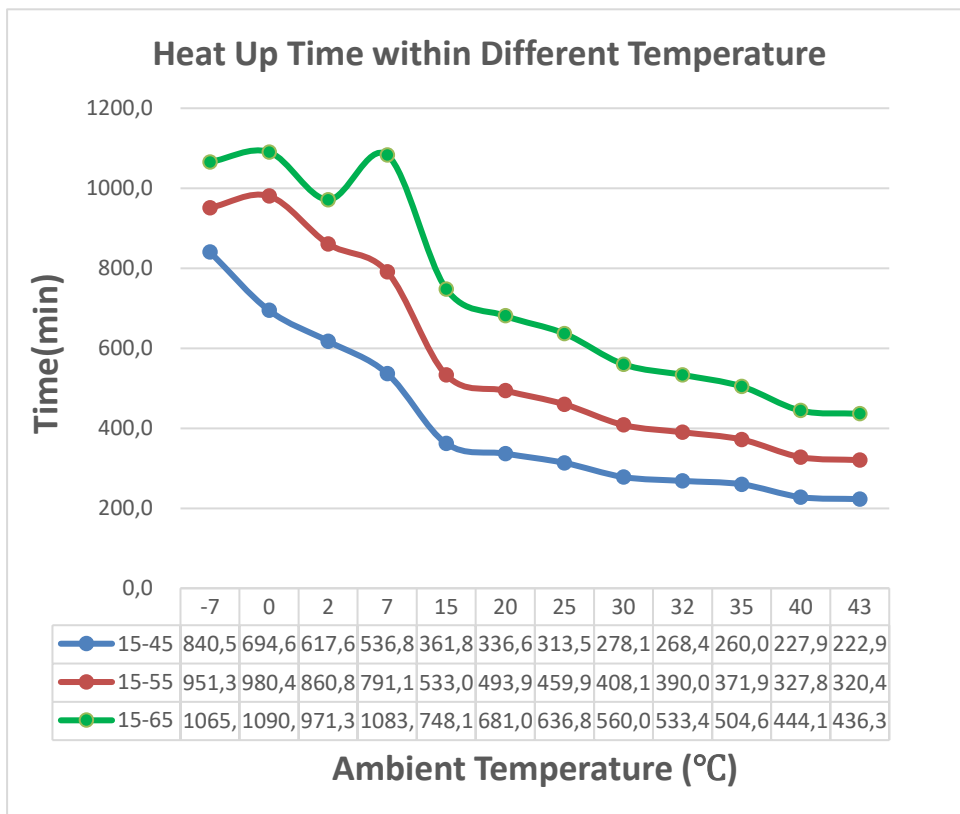

The curve between capacity and ambient temperature

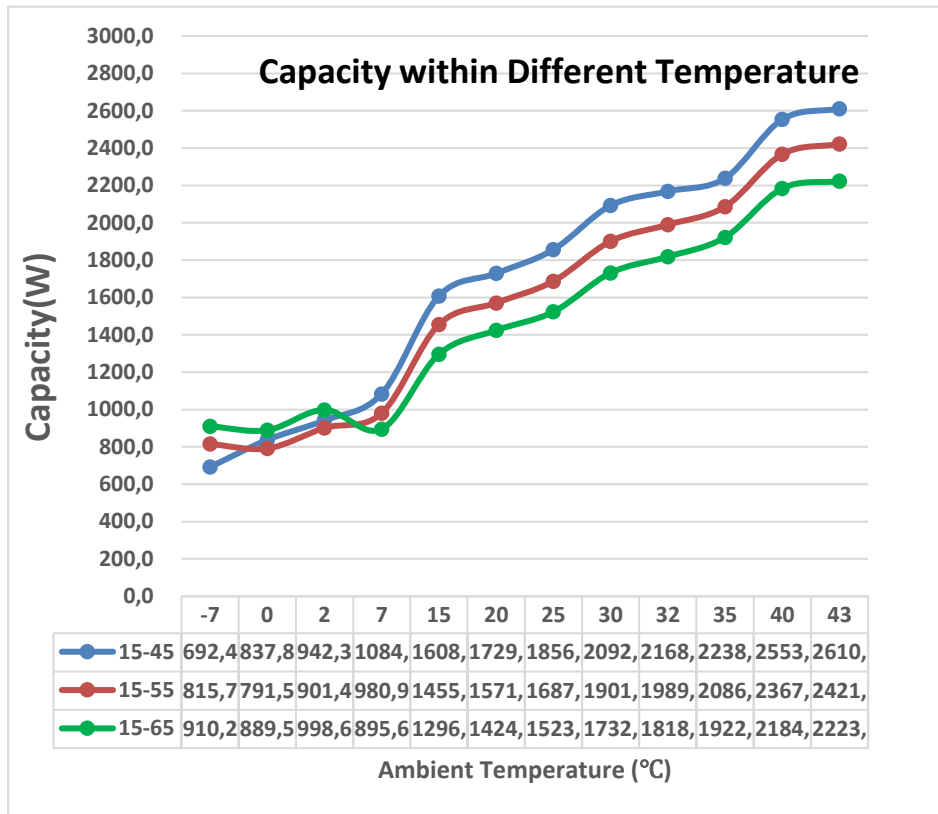

The curve between COP and ambient temperature

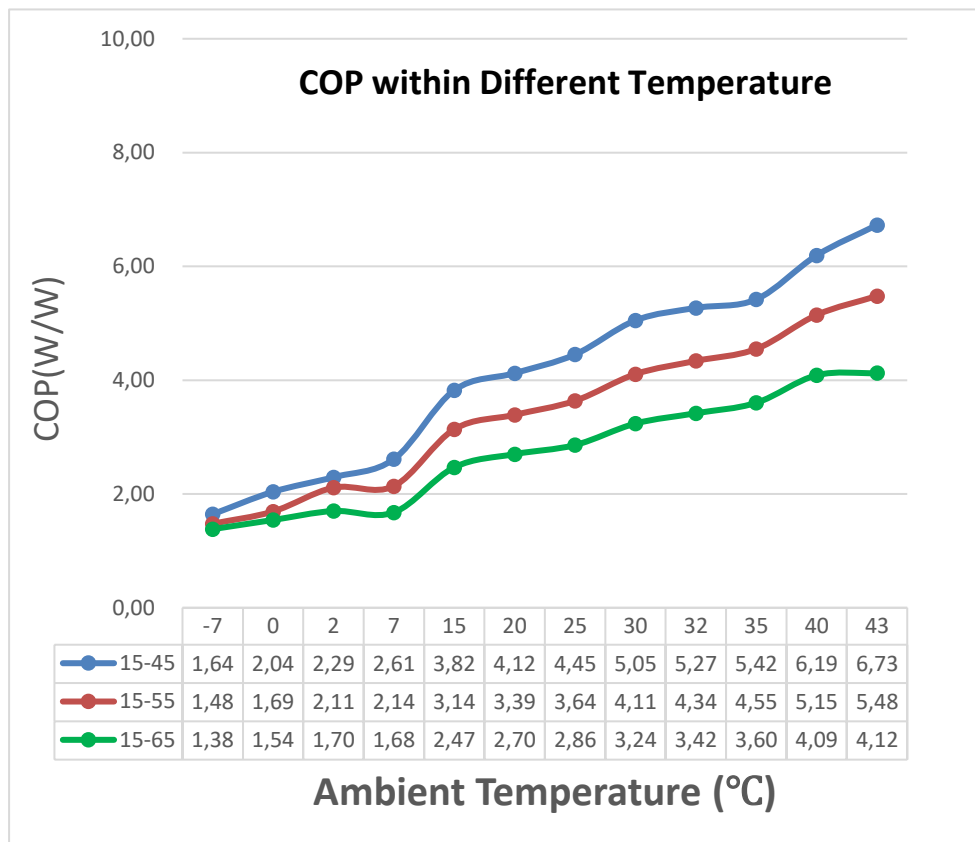

7. Wiring diagram

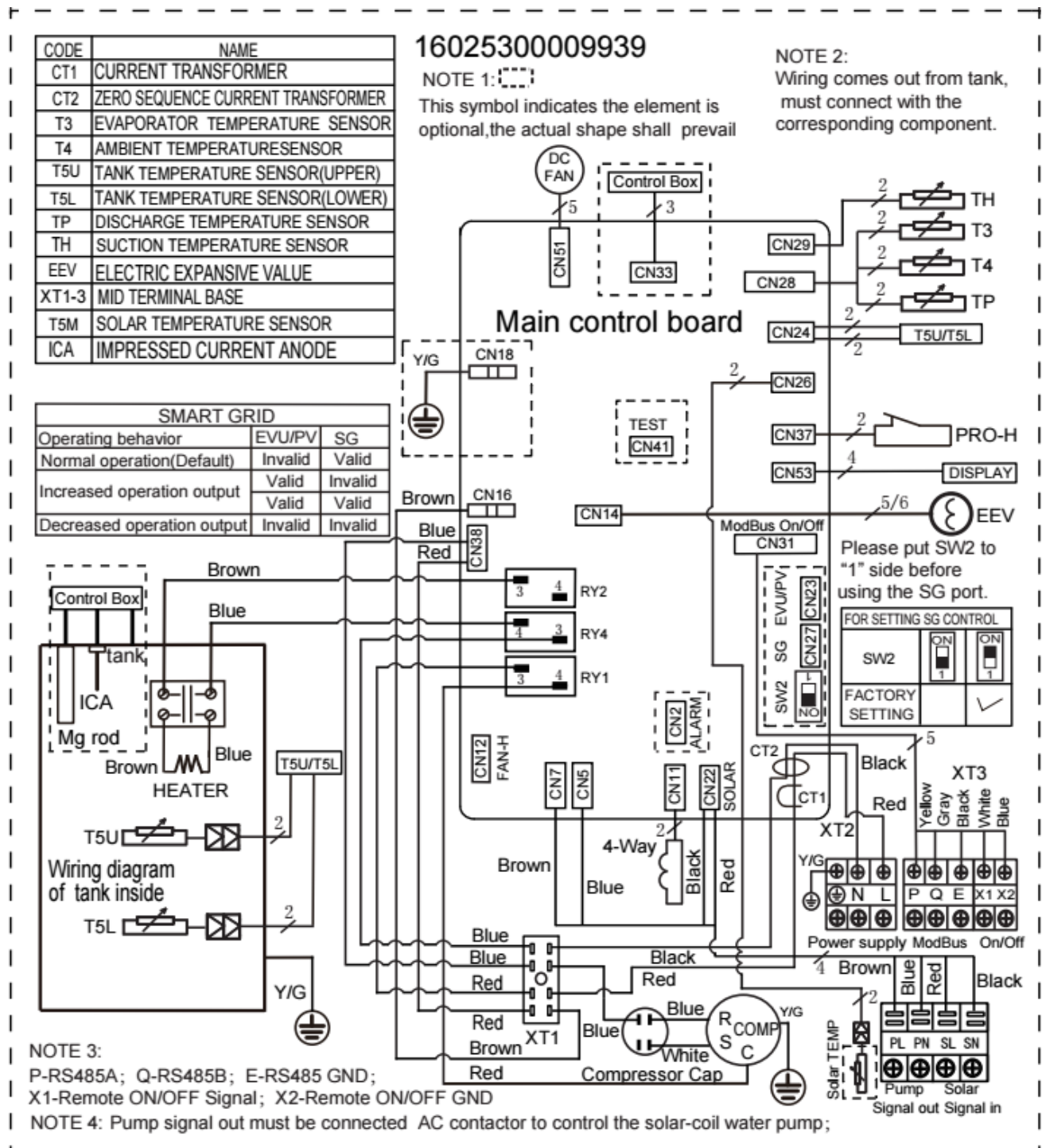

Smart Grid and EVU function:

Smart Grid: The device has a reserved connection port on the main control PCB, to realize this function it is necessary to connect a third-party smart grid switch externally. There is a dip switch next to the SG port, factory setting SW2 = ON (conduct electricity from the grid directly), it is required to manually dial the dip switch to 1 (disconnect) before connecting an external smart grid switch, after which the smart grid icon will light up on the display when the system gets electricity from the grid.

EVU: The device has a reserved EVU port on the main control PCB, it can be connected to photovoltaic input (energy manager) that supports water heater control. The EVU icon will light up on the display

when the system gets photovoltaic input.

Function control logic:

EVU=0 refers to no free photovoltaic power, EVU=1 refers to free photovoltaic power

SG=0 refers to high price electricity, SG=1 refers to low price electricity

1. When EVU=0 and SG=1, the unit operates normally
2. When EVU=1, SG=1 or 0, there is free photovoltaic power, and the system will automatically raise the set temperature to the max set temperature and store hot water, which can achieve the purpose of energy saving
3. When EVU=0 and SG=0, the unit is forced to stop running: (disinfection operation can work after entering the disinfection time)

8. Installation

8.1 Transport

- Please carry the unit according to the factory state, do not disassemble it by yourself.
- This unit is heavy, it needs to be carried/handling by two people or more, otherwise it might cause injury to people and damage to the unit. Please, comply the local Occupational risk prevention ORP regulations.
- Keep away your fingers from the vanes. In order to avoid scratch or deformation of the unit surface, protect the surface from contacting with hard objects.
- While moving, please use the handles on both sides of the unit.

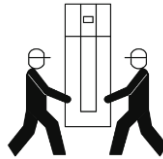

8.2 Location requirements

IMPORTANT! The unit must be installed indoor, it is not allowed to be installed outdoor without shelter. Avoid installation in direct sunlight.

WARNING:

- In case of rain entering to internal components of the unit, the component might be damaged or causing physical danger.
- In terms of the unit connect with duct reaching to outdoor, a reliable water resistant measure must be conduct on the duct, to prevent water from dropping into internal of the unit.
- The unit needs to be securely fixed, otherwise it may cause heavy consequences.

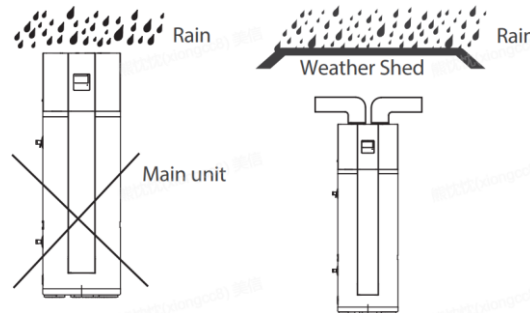

- Enough space for installation and maintenance shall be preserved.
- The ground surface should be flat, and inclined no more than 2°.
- The ground must able to bear the weight of the unit and suitable for installing the unit without increasing noise or vibration.
- To smoothly drain condensate water from the unit, please install the unit at a horizontal floor. Otherwise, ensure the drain vent is at the lowest level.
- The air inlet and outlet should be free from obstacles and strong wind.
- The operation noise and air flow expelled shall not affect neighbors.
- No obstacle around the unit.
- No flammable gas is leaked nearby.

- It is convenient for piping and wiring.
- The ambient air temperature must also be considered when installing this unit, in heat pump mode the air inlet temperature must be above -7°C and below 43°C . If the inlet air temperature falls outside these upper and lower limits, the electrical elements will be activated to meet the hot water demand and the heat pump does not operate.

CAUTION:

- If the unit is installed on the balcony, the water full weight should not exceed the load-bearing limit of the balcony.
- If the unit has to be installed on a metal part of building, make sure the well electric insulation which should meet the relevant local electric standard.
- The unit installed in indoor space might cause indoor temperature decrease and noise. Please take preventive measures for this.
- The unit should be located in an area not subject to freezing temperatures. The unit located in unconditioned spaces (i.e., garages, basements, etc.) may require the water piping, condensate piping, and drain piping to be insulated to shelter against freezing.
- Installing the unit in any of the following places may lead to malfunction (If it is inevitable, consult the supplier).

-The site contains mineral oils such as lubricant of cutting machines.

-Seaside where the air contains much salt.

-Hot spring area where corrosive gases exist, e.g., sulfide gas.

-Factories where the power voltage fluctuates seriously.

-Inside a car or cabin.

-The place with direct sunlight and other heat supplies. If there's no way to avoid these, please install a covering.

-Place like kitchen where oil permeates.

-Place where strong electromagnetic waves exist.

-Place where flammable gases or materials exist.

-Place where acid or alkali gases evaporate.

-Other special environments.

8.3 Maintenance space (Unit: mm)

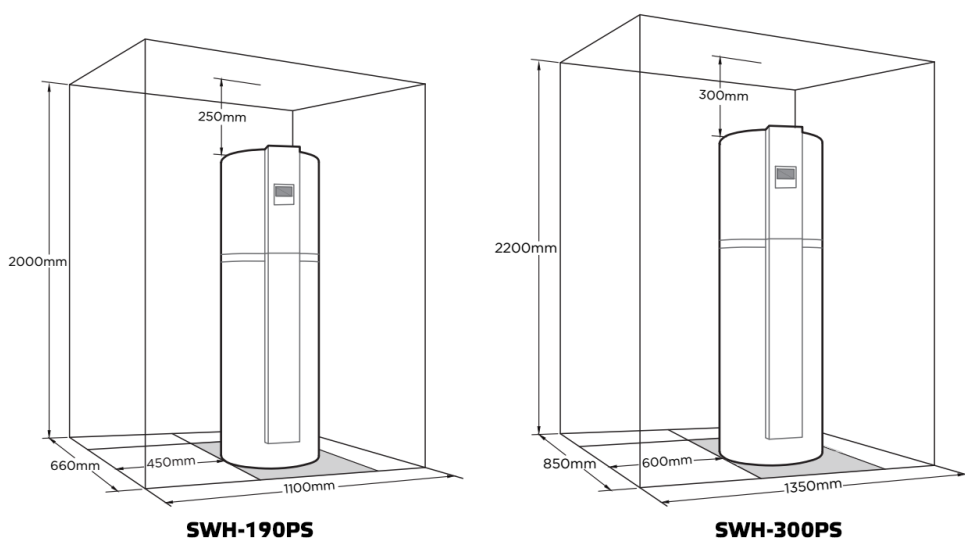

8.4 Fixing method

CAUTION:

In order to prevent accidental fall, please fasten the water heater to the walls.

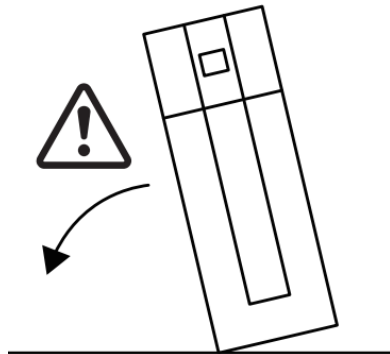

Water heater fixing steps are as follows:

- 1 Take off the front decorative board.
- 2 Install the expansion bolts (not provided) in the wall according to the drawing.
- 3 Fix the end with less holes for mounting the fixing strip on the expansion bolt.
- 4 Tighten the fixing strip and fix the other end to the second expansion bolt through appropriate hole.
- 5 Check whether the water tank is safely and securely fixed. If there's extra fixing strip, please cut off.
- 6 Put back the decorative board.

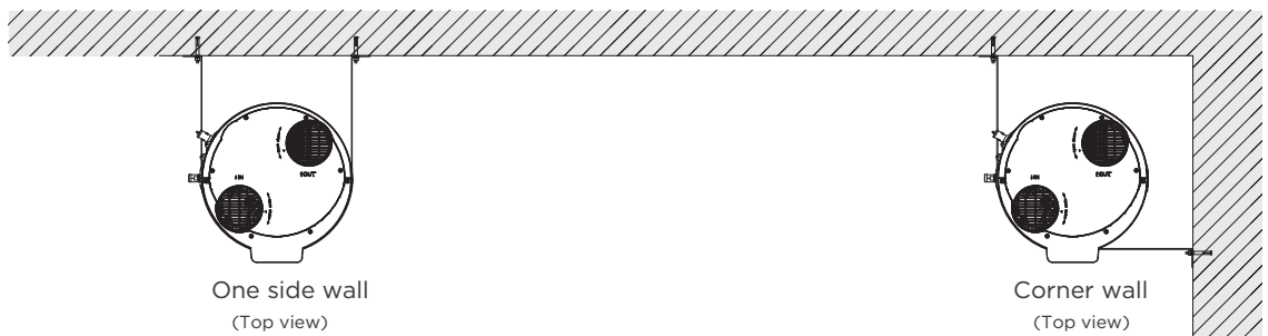
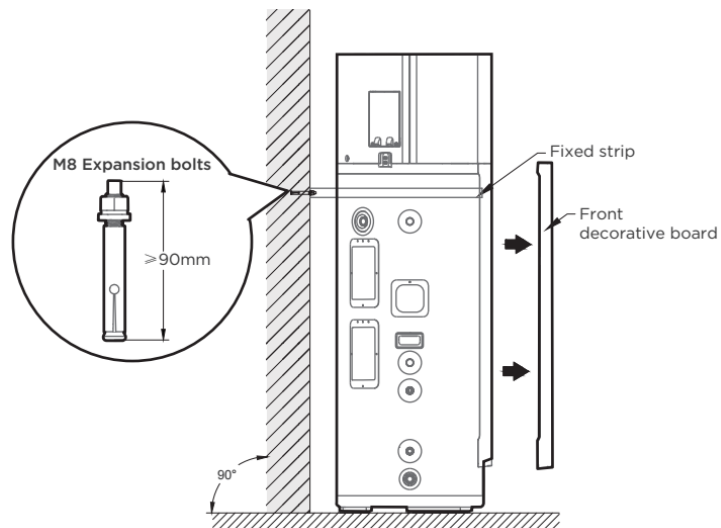

CAUTION:

- The appearance and installation orientation of the unit shown above are for reference only and can be adjusted according to the actual installation.
- The position of the fixed strip can be adjusted according to the actual situation, make sure the unit is safely and securely fixed.
- The expansion bolt requirement must match the weight of the product (loaded with water).

8.5 Water system piping (Hydraulic connection)

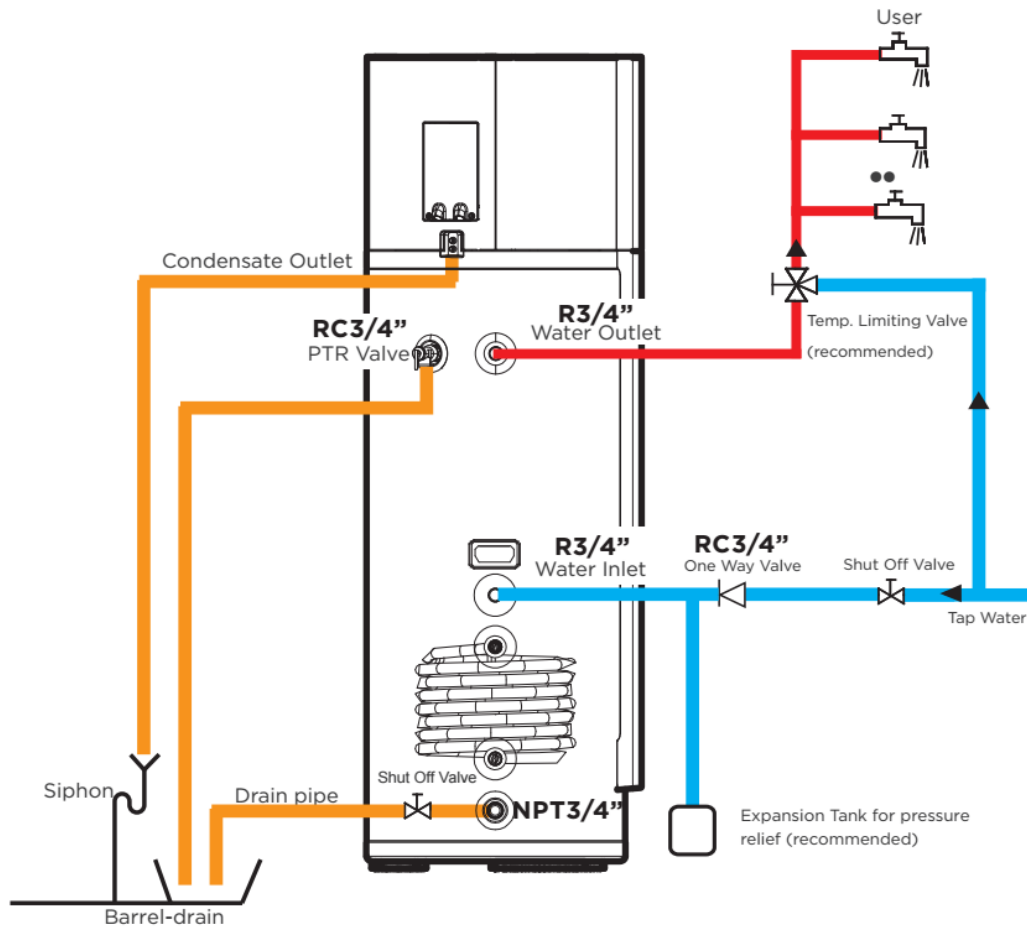

Connect water pipes as the above figure.

Water temperature limiting valve is recommended for mixing the inlet cold water with outlet hot water to prevent burns caused by hot water.

Check before connection, make sure the pipe is clean and free of any foreign matter.

It is recommended to use dielectrical connectors to avoid potential corrosion; When installing a circulation pump between the domestic hot water and cold-water inlet, dry burning protection may be accidentally triggered. It is recommended to enter engineering mode and turn o- this function (set the parameter F15=0).

1) Cold water connection

The spec of the water inlet thread is R3/4" (external thread). Use well-insulated pipes to connect the water inlet and the house's water supply. Install the one-way valve (thread RC3/4") in accessories to the inlet pipe to prevent water from flowing backwards.

CAUTION:

In any type of installation there should be a stop valve ((not provided) on the cold water inlet.

We recommend a supply pressure of 3~4 bar (0.3 to 0.4 MPa). If the inlet water pressure is less than 0.15MPa, a pump should be installed at the water inlet. If the main water supply pressure is higher than 7 bar (0.7MPa), a reducing

valve should be used at the water inlet pipe.

If there is a large fluctuation in the water pressure of the system, it is recommended to install an expansion vessel (actual volume $\geq 7\%$) to balance the pressure.

For regions with a lot of scale ($T_h > 20^\circ\text{f}$), we recommend to treat the water. The hardness after softener has to be higher than 15°f . The use of a softener does not influence the warranty if the softener is approved for the country of installation and set to the rules of art, with regular checking and maintenance.

Local criteria of drinking water quality have to be respected.

2) Hot water connection

The spec of the water outlet thread is R3/4" (external thread). Use well-insulated pipes to connect the water outlet to the water terminal in the house.

CAUTION:

Water temperature over 50°C can cause severe burns instantly or death from scalds. We recommend installing a thermostatic mixer valve on the water supply line.

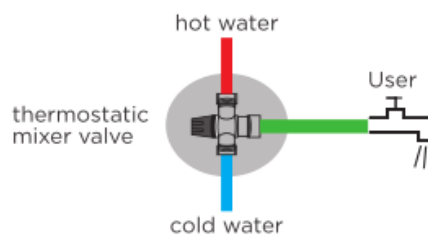

3) Drainage connection

The spec of the Drainage is NPT3/4. The unit comes with a plug. Replace the plug with a shut of valve and connect the unit to the drain pipe open to air.

4) Condensate evacuation

Connect the two condensate drain pipes in the fitting to the condensate outlet.

Depending on the degree of humidity in the air you can get up to 0.25L/h of condensation. The condensate drain line should not be connected to the house sewer directly. Instead, use a siphon which contains water to prevent the unit from corrosive gases and to prevent odours from escaping.

5) Installation of the pipe for PTR valve

The spec of the safety valve connecting thread is RC3/4" (internal thread) and it was installed already.

The overflow of the safety valve has to be connected to a drainpipe that is open to the air, and connect to the used water evacuation through a siphon. Installation has to be in a frost-free environment. The safety valve has to be operated regularly (every half year) to check the working condition.

CAUTION:

- In case of installing it at a place where outside temperature below freezing point, insulation must be provided for all hydraulic components.
- The handle of PTR valve should be pulled out once per half a year to make sure that there is no jam of the valve. Please beware of burn, beware of the hot water from the valve.
- The drainage pipe should be well insulated in order to prevent water inside pipe from freezing in cold weather.

WARNING



Do not block off the safety valve drainage pipe. It will cause explosion and injury, if do not comply with the above instruction.

Tips: Condensate may be leaked from unit if drainage pipe is blocked or unit operates in high humidity environment, a drainage pan is recommended as shown as following figure.

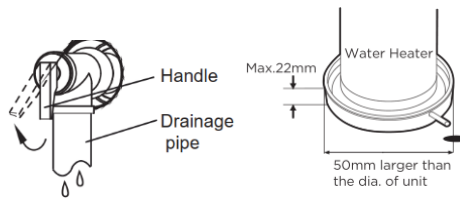

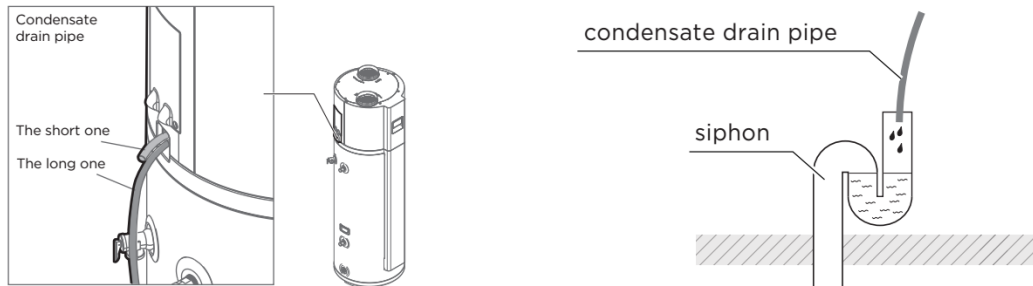

Once the water piping work is done, turn on the cold-water inlet valve and hot water outlet valve and start filling the tank. Check pipeline to make sure there is not any leakage. When water flow smoothly out from water outlet pipe (tap water outlet), the tank is full, turn o- all the outlet valves.



8.6 Air duct connection

The total pressure drop of ducts and accessories for air inlet and outlet has to be less than 80 Pa. It is strongly recommended to use rigid ducts and the recommended length of ducts has to be respected.

The following table lists the corresponding pressure drops and equivalent lengths for different air ducts and accessories.

		1m PVC/HDPE straight pipe	1m PVC/HDPE straight pipe	Filter
Type				
SWH-190PS (Ø160)	Pressure drop(Pa)	2.5	9.5	19.0
	Equivalent length (m)	1.0	3.8	7.6
SWH-300PS (Ø190)	Pressure drop(Pa)	2.0	8.0	15.2
	Equivalent length(m)	1.0	4.0	7.6

It is necessary to enter engineering mode and set parameter F40 according calculated pressure drop, as shown in the following table.

Total pressure drops	0-20Pa	20-40Pa	40-60Pa	60-80Pa
F40	0	1	2	3

NOTE:

- The pressure drop in the duct will decrease the air flow rate, which will reduce the capacity of the unit.
- Condensation may form on the outer surface of the ducts, harder in the exhaust air one. Be aware of this condition. We strongly recommend using thermally insulated ducts or thermally insulating the installed ducts.
- The filter must be installed at the air inlet of the unit in dirty and dusty environments. As for the ducted unit, the filter, if needed must be placed at the duct inlet. In normal air conditions, only a grill to prevent the entrance of foreign bodies.

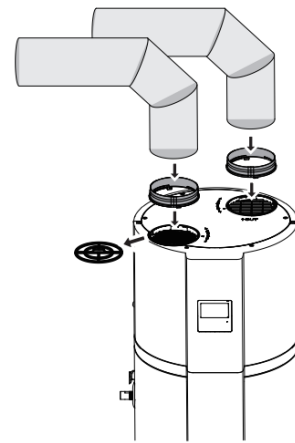
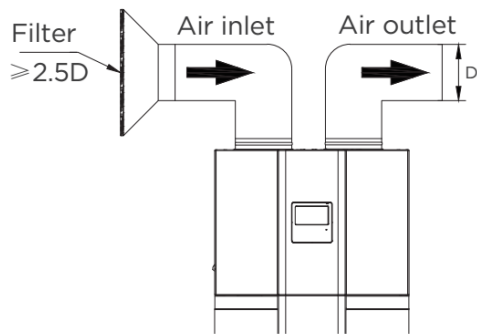

The grille or filter must be provided by the owner. The recommended mesh size is around 1.2 mm.

1. Typical installation

Different ways of air ducts connection

Type					
181L	Maximum piping length L1+L2 (Without filter)	32m	28m	28m	24m
270L		40m	36m	36m	32m

Different directions of air ducts connection

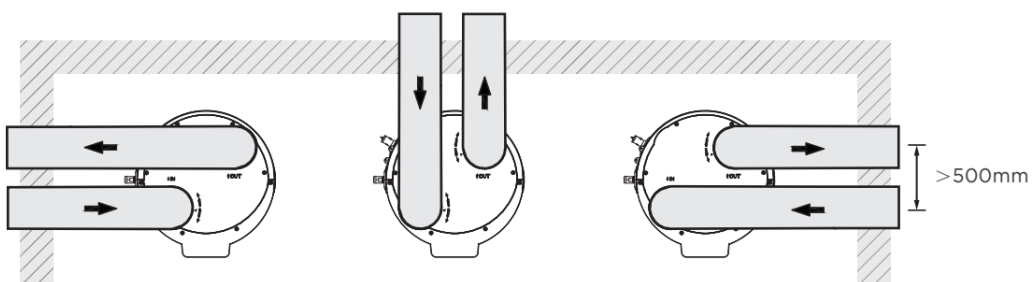

8.7 Electric connection

CAUTION:

- The power supply should be an independent circuit with rated voltage.
- Power supply circuit should be earthed.
- The wiring must be performed by professional technicians in accordance with national wiring regulations and the circuit diagram. (Please open the front cover of unit's head, you will see the circuit diagram on the electronic control box.)

- A circuit breaker which has at least 3mm separation distance in all pole and a residual current device (RCD) with high sensitivity, at least 30 Ma, shall be incorporated in the power supply wiring according to the national rule. Compliance with local legislation in force is mandatory in all cases.
- Set the electric leakage protector according to the relevant electric technical standards of the state.
- The power cable and the signal cable shall be laid out neatly and properly without mutual interference nor touching the connection pipe or valve.
- After wire connection, check it again and make sure the correctness before power on.
- Optional element will not be shipped with the machine. If you have installation requirements, please contact the after-sales professional technical personnel to purchase compliant components, and have them installed by professional technical personnel.

1 Specifications of power supply

The recommended power cord model is H05RN-F.

You can choose the power cord according to the following table, and it should comply with local electric standard.

Power supply	220-240V~, 50Hz, 1Ph
Min. diameter of power supply cord (mm ²)	1.5
Earth cord (mm ²)	1.5
Manual Switch(A) Capacity/Fuse(A)	30/25
Creepage Breaker	30mA ≤ 0.1sec

2 Power cable connection

The steps for connecting power cables are as follows:

- 1) Remove both screws and take off the junction cover; Remove both screws and take off the metal protective cover;
- 2) Route the power cable through the bottom cable hole; Connect the power cable to  , N, L and fix the cable with the below tie; The power cable should be routed through reserved left hole on the junction box cover. Put the metal protective cover and junction box cover back.

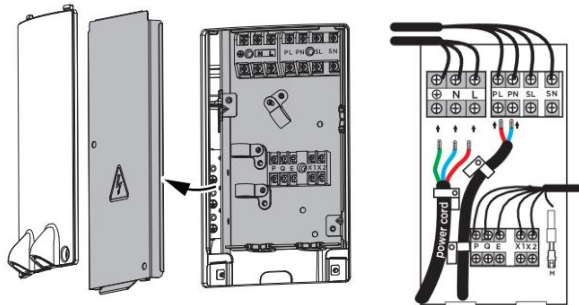

NOTE:

- The cross-sectional area of Additional cables shall not be less than 1.0 mm²
- Using wire strippers, strip the rubber jacket from both ends of the signal cable to reveal approximately 15cm (5.9") of wire.

Strip the insulation from the ends.

Using a wire crimper, crimp u-lugs on the ends.

- When connecting the wires, strictly follow the wiring diagram found inside the electrical box cover.
- Additional cables need to be connected after the power cable in order not to block the installation of it.

WARNING:

Ensure the ground wire has the longest length, to prevent it from being pulled out.

The unit must be installed with RCD near the power supply and must be effectively earthed.

Additional cables need to comply with code design 60245 IEC 57, i.e. H05RN-F and must be installed by professionals;

To prevent loosening and breakage, the routing of strong/weak power supply lines needs to be secured through cable clamps.

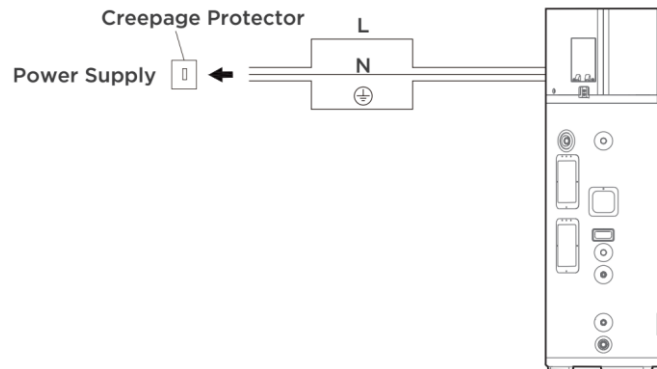

3 Electrical connections with different integrated systems

With this unit system, three different systems are available.

The three integrated systems correspond to the three electrical wiring connections showed in the figures and there are also three different settings in the engineering mode. Different wiring configurations need to be implemented for each different implemented integrated system.

Warning

It is important to ensure that the electrical connections done, are appropriate to the engineering settings.

CAUTION

- When wiring the power supply, please add additional insulation sheath at the place without rubber insulation layer.
- This unit should be installed by a qualified professional electrician in accordance with the local regulations. The selection of cables and wires should be in accordance with local regulations requirements.
- For safety reasons, up to 30mm insulation can be peeled off at the end of the power supply cord, if the stripping wire is too long, there may be a risk of short circuit or insufficient insulation protection.
- The electrical connection must be carried out by authorized installer. and it is strictly forbidden to carry out transformation and setting beyond the guidance specifications.
- Risk of electric shock: When the equipment is repaired, it is necessary to turn off the power supply and its external power supply to prevent the risk of electric shock.
- The temperature of the solar collector pipe may be too high, please do a good job of heat insulation along the way, and prohibit contact with the power supply wire to avoid damaging the wire.

8.8 Installation checklist

Location & Space

- The floor must be able to bear the weight of the unit when filled with water.
- Located indoor such as a basement or garage) and in a vertical position. Protected from freezing temperature.
- Allow sufficient space for maintenance and service.
- Allow sufficient air for the heat pump to operate. The water heater heat pump must have unrestricted air flow.
- The unit cannot be placed into any type of closet or small enclosure.
- The site location must be free from any corrosive elements in the atmosphere such as sulfur, fluorine, and chlorine.

These elements are found in aerosol sprays, detergents, bleaches, cleaning solvents, air fresheners, paint, and varnish removers, refrigerants, and many other commercial and household products. In addition, excessive dust and lint may affect the operation of the unit and require regular cleaning.

- The ambient air temperature must be above -7°C and below 43°C . If the ambient air temperature goes below this lower limit the electrical elements will be activated to meet the hot water demand and the heat pump will not operate.

Hydraulic connection

PTR valve (Temperature and pressure relief valve) has to be properly installed with a discharge pipe going to an adequate drain and sheltered from freezing.

- All pipes must be properly installed and with no water leakage.
- Water temperature limit valve or mixer tap (recommended) has been installed.
- Condensate drain lines must be installed with an easy access.
- The condensate drain outlet must be at the lowest position of the unit.
- The condensate drain pipes have been connected to a drain siphon.

Electrical Connections

- The water heater requires 220-240 VAC for proper operation.
- Cable specifications and connections must comply with all local applicable codes and the requirements of this manual.
- Water heater and electrical supply must be properly earthed.
- Proper overload fuse or circuit breaker protection must be installed.

Post Installation Review

- Make sure the users understand how to use the User Interface Module to set the different modes and access the different functions.
- Make sure the users understand the importance of routine inspection/maintenance of the condensate drain pan and lines. This is to help prevent any possible drain line blockage resulting in the condensate drain pan overflowing.
- IMPORTANT:** Water coming from the plastic shroud is an indicator that both condensations drain lines may be blocked. Immediate action is required.
- To maintain optimal operation check, remove and clean the air filter.

8.9 PCB I/O Ports description

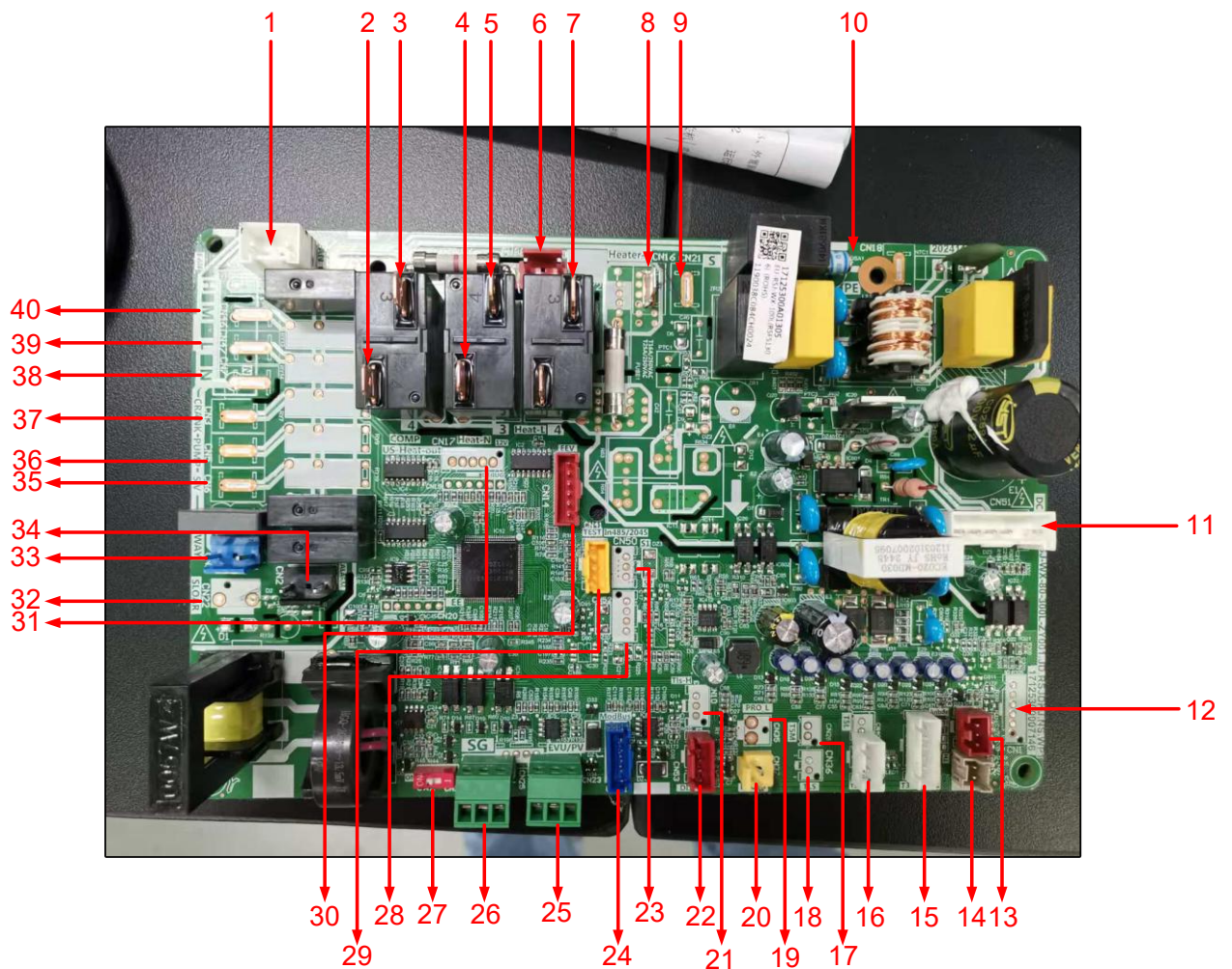

No.	Name	CN#	Meaning	No.	Name	CN#	Meaning
1	FAN-H	CN12	The outer Fan	21	TLS-H	CN10	Water level switch for water leakage detection in the water tray
2	Comp out	RY1-4	Comp output	22	DISPLAY	CN53	DISPLAY
3	Comp in	RY1-3	Comp input	23	in485/2045	CN50	North American 2045 port
4	E-heat-N-in	RY4-3	Heat-N input	24	Modbus and remote switch On/Off	CN31	Modbus and remote switch On/Off
5	E-heat-N-out	RY4-4	Heat-N output	25	EVU/PV	CN23	Photovoltaic signal
6	POWER-in	CN38	Board power supply	26	SG	CN27	Smart Grid
7	E-heat-L-out	RY2-3	Heat-L output	27	Switch	SW2	Factory Setting
8	E-heat-L-in	CN16	Heat-L input	28	LM-det	CN52	Refrigerant detection reserved port
9	S	CN21	S-signal	29	TEST	CN41	Test Port
10	PE	CN18	Earth GND	30	EEV	CN34	Electronic Expansion Valve
11	DC FAN	CN51	DC FAN	31	2 x E-heat	CN17	Outlet E-heat control

12	Auto inlet water Valve	CN1	Auto inlet water Valve	32	Solar Input	CN22	Solar Input (strong current)
13	Anode	CN33	E-MG	33	4-Way	CN11	4-Way Valve
14	Th	CN29	Comp Suction Temp Sensor	34	Alarm	CN2	Alarm
15	T3/T4/Tp	CN28	T3: Evaporator Inlet Temp T4: Ambient Temp Sensor TP: Comp Discharge Temp Sensor	35	S.V	CN6	Electromagnetic valve
16	T5U/T5L	CN24	T5U: Upper Tank Water Temp Sensor T5L: Lower Tank Water Temp Sensor	36	PUMP	CN5	Solar Pump
17	T5M(TS)	CN26	Middle Tank Water Temp Sensor (Solar Temperature Sensor)	37	Crank	CN3	Crank Heater
18	TLS	CN36	Chassis leak detection	38	N	CN7	N output
19	PRO-L	CN35	LOW Pressure Switch	39	L	CN47	Low Fan output
20	PRO-H	CN37	High Pressure Switch	40	M	CN46	Middle Fan output

9. Use

9.1 Checking list before trial- running:

- ✧ Correct installation of the system.
- ✧ Correct connection of water/air piping and wiring.
- ✧ Smooth condensate drainage and proper installation of all hydraulics.
- ✧ Correct power supply.
- ✧ No air in the water pipeline and all valves opened.
- ✧ Effective electric leakage protector installation.
- ✧ Sufficient inlet water pressure (between 0.15MPa~0.7Mpa).
- ✧ Unit completely filled with water.

CAUTION: If the unit has been placed in horizontal position, keep it in a vertical position for at least 60min before start up.

9.2. Initial startup

Follow the steps below to start up the unit.

- 1) Filling the tank with water before operation

Please ensure that the tank is full of water before turning on the power. Water filled method is as follows:

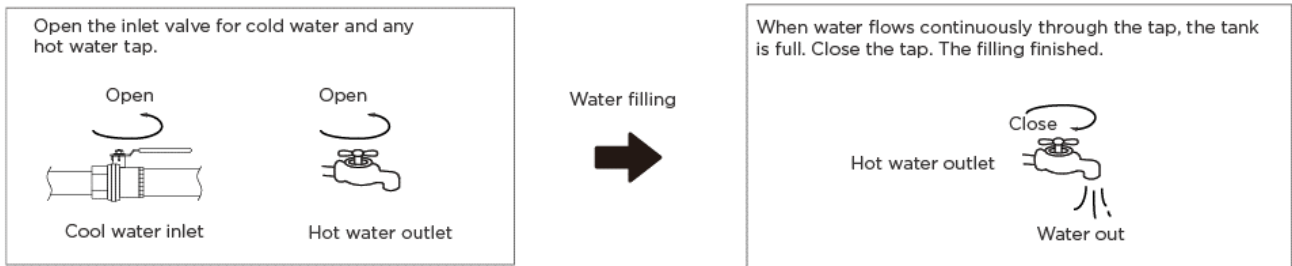

The water tank should be filled when the unit is used again after emptying.



The water tank must be filled when using the unit again after emptying it.

Ensure that there is no water leakage in the pipe before starting up.

Operation without water in water tank may result in the damage of E-Heater. Manufacturer is not liable for any damages caused by this issue.

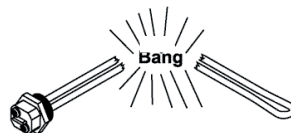

CAUTION:

If the unit needs cleaning, moving, stop using, etc., the tank should be emptied. Emptying Method is as follows:

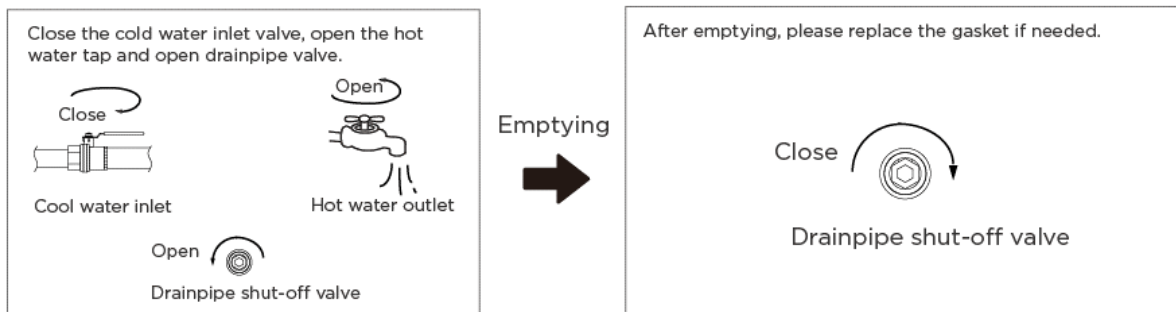



CAUTION: The water will flow through drainpipe shut-of valve! It could be hot! Pipe it into the sewage system!

2) Start up

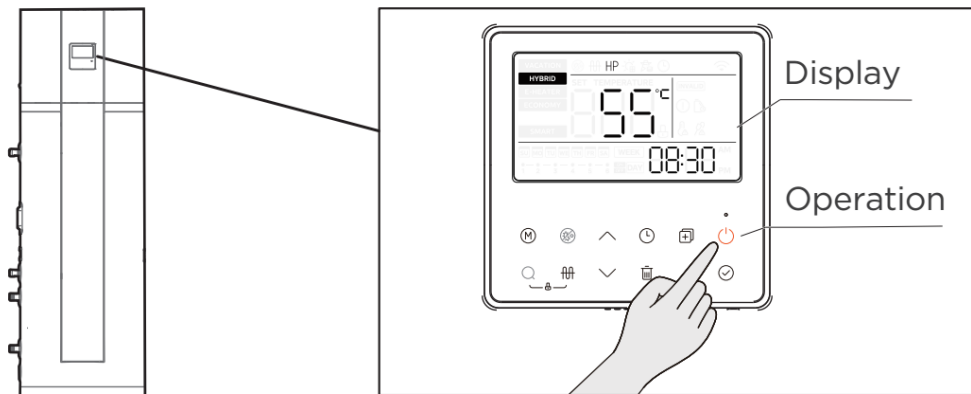
After powered on, the display will light up.







Press  → the unit will be switched on → press  to select the setting temperature (38-70°C) → press  → The unit will automatically select heat source and start to heat water to set temperature.

- Change the running mode

Press the  button to select running mode.

- Date and time setting

In the main screen, press and hold  for 3 seconds to enter the weekday setting, press  to select the date, press  to enter the time setting, use  to modify the time. Press  to finish the setting and return to the main screen. The factory default setting gives priority to heat pump operation.

During installation, it is necessary to make the operating mode selection settings with the customer and guide the customer in the use of the equipment.

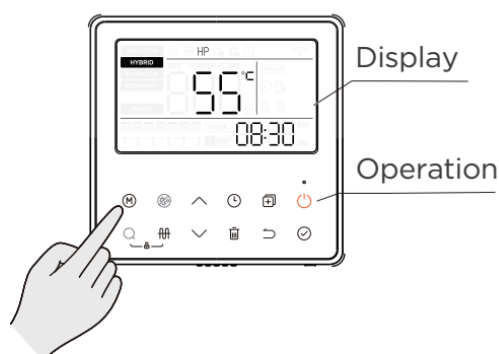

Water temperature display

The temperature shown on the display is the maximum of the temperatures registered by the upper sensor and the lower sensor. It is possible that once the display shows that the setpoint temperature has been reached on one of the sensors, compressor still running, because the water temperature around the other sensor does not get to set temperature.

Heat source shift

- Unit has two kinds of heat sources: heat pump (compressor) and electric heater. Unit will automatically select heat sources to heat water to the target temperature.
- For ECONOMY and HYBRID modes, the default heating source is heat pump. If inlet air temperature is out of the range of heat pump, heat pump will stop running, the unit will shift automatically to activate E-heater, then if the inlet air temperature goes into the running range of heat pump again, it will stop E-heater and shift automatically to heat pump again.
- If the water set temperature is higher than Max. hot water temperature (Heat pump working limits), for the existing inlet air temperature, the unit will first activate the heat pump until Max. Temp (Heat Pump working limits), then stop heat pump, and activate E-heater to heat the water continuously until the desired temperature is reached.
- Manually E-Heater operation is available. If manually activate the E-heater when heat pump running, E-heater and heat pump will work together until the water temperature gets to set temperature. So, if want to heat quickly, please manually activate E-heater.

10. Maintenance

CAUTION: Always turn off your Air-source Heat Pump Water Heater system and disconnect its power supply before cleaning or maintenance.

Check the connection between the power supply plug and socket and ground wiring regularly;

It is recommended to set a lower temperature if the outlet water volume is sufficient, to decrease the heat release, prevent scale and save energy.

If the system will be stopped for a long time, please do as follows to avoid freezing of inner tank and damage of E-heater:

- Shut off the power supply;
- Release all the water in water tank and the pipeline and close all the valves;
- Check the inner components regularly.

Clean the air filter every month in case of any inefficiency on the heating performance. In terms of the filter set in air inlet directly (namely, air inlet without connecting with duct):

- Unscrew the air duct connector anti-clockwise.
- Take out the filter and clean it completely;
- Remount it to the unit

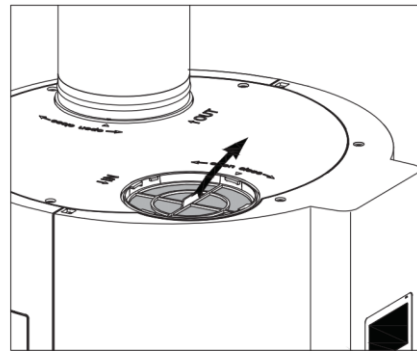
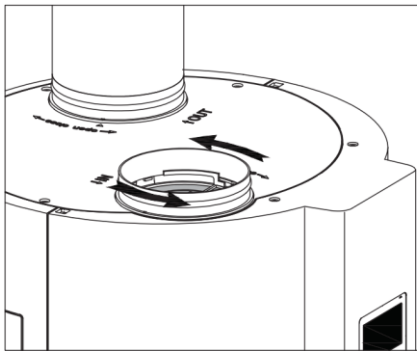

Operate and check the PTR valve every 6 months to prevent blockage.

CAUTION: The following maintenance items need to be performed by qualified persons. Please contact the supplier or after sale service.

It is recommended to clean the E-heater every 6 months to maintain efficient performance.

Check the Magnesium rod every 6 months and change it if it has been used out.

Please contact professional technical after-sales service if the battery needs to be replaced.

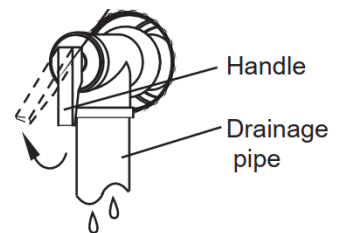

Recommended regular maintenance table

Checking item	Checking content	Checking frequency	Action
1	Air filter (inlet)	Every month	Clean the filter.
2	Magnesium rod	Every half year	Replaced if it has been used out.
		Check every half year after the impressed current anode reports a fault.	It is recommended to replace the impressed current anode and the physical magnesium rod.
3	PTR valve	Every half year	Check for blockage
4	E-heater	Every half year	Clean the E-heater.

For more details, please contact the supplier or the after-sale service.

Restart after a long term stop

When the unit is restarted after a long term stop (trial running included), it is normal that outlet water is unclear. Keep the tap on and the water will be clean soon.

11. Trouble shooting

Error phenomenon shooting

Error phenomenon	Possible reason	Solution
The tap water is cold and the screen turned off.	Bad connection between power supply plug and socket	1. Plug in; 2. Setting a higher temperature; 3. Contact service center.
	Setting water temperature too low.	
	Temperature sensor broken. PCB of indicator broken.	
No hot water coming out of the tap.	Public water supply ceased.	1. Waiting for public water supply to recover. 2. Waiting for inlet water pressure to increase. 3. Open water inlet valve.
	Cold water inlet pressure too low (<0.15 MPa).	
	Cold water inlet valve closed.	
Water leakage	Hydraulic pipeline joints are not sealed well. A pipe or fitting is broken.	Check and reseal all joints. Check piping.

Malfunction and protection codes

Code	Content
EH0b	Tank and LCD panel communication error.
EH00	Machine working parameters are abnormal.
EH03	Dc fan fault
PH15	Electric leakage error. If PCB current induction circuit check the current difference between L, N > 14mA, system consider it as "electric leakage error".
EC54	Compressor discharge temperature sensor TP error.
EH5H	Compressor suction temperature sensor TH error
EC53	Ambient temperature sensor T4 error.
EC52	Evaporator temperature sensor T3 error.
EC5L	Error of sensor T5L (Lower water temperature sensor).
EC5U	Error of sensor T5U (Upper water temperature sensor).
EH5N	Error of sensor T5M (Solar collector temperature sensor).
EH5d	Electric heater open-circuit error.
EHLA	When the ambient temperature T4 is out of the compressor operating range, the compressor stops, and EHLA is displayed until T4 returns to the normal range. Only works on units without electric heaters. Devices with electric heaters will never display "EHLA".
EHHP	Heat pump system fault. When PH20, PH21, PC30, PC06 any protection appears 3 times or the protection lasts 1 hour.
EHEA	Impressed current anode default.
PHdH	Dry burning protection
PH20	Compressor abnormally stopped protection. The discharge temperature is not so higher than evaporator temperature after compressor running a term.
PH21	The working current of the compressor is too large.
PH24	Frost protection. T5L < 4°C and T4 < 7°C.
PC30	System high pressure protection ≥3.0MPa active; ≤2.4Mpa inactive
PC06	High TP protection. Tp > 110°C(185L), Tp > 105° C (275L) .Protection active; Tp < 90° C Protection inactive.
PH9b	Overtemperature protection. The current water temperature exceeds the Maximum target temperature by more than 5°C.
PH91	Low T3 protection.

EH0b

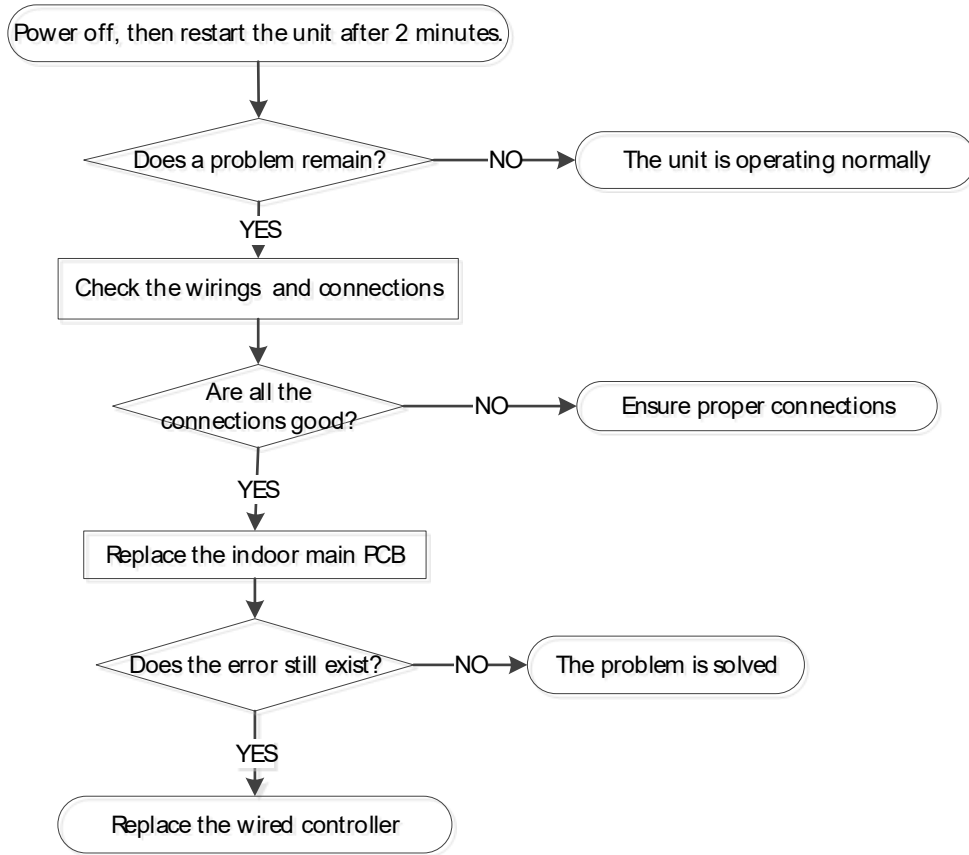

EH00

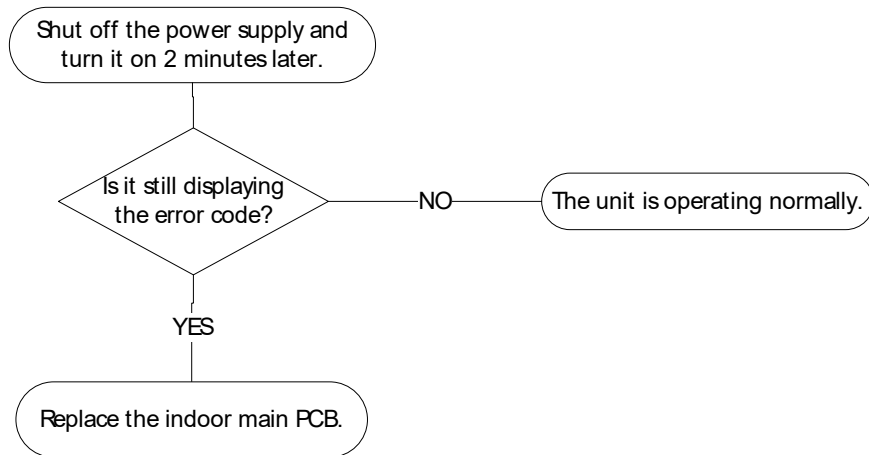

EH03

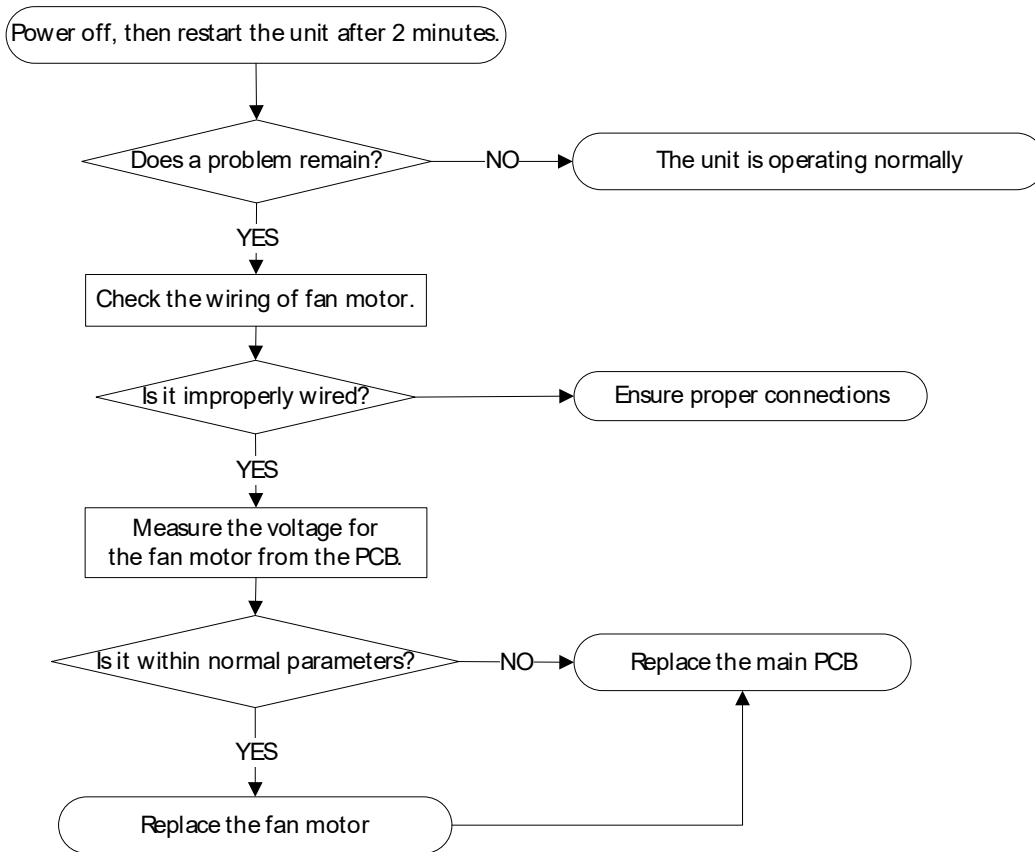

PH15

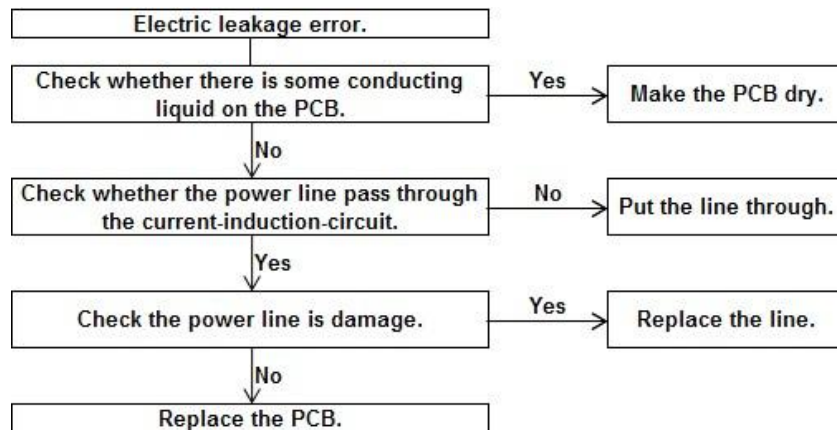

EC52, EC53, EC54, EH5H

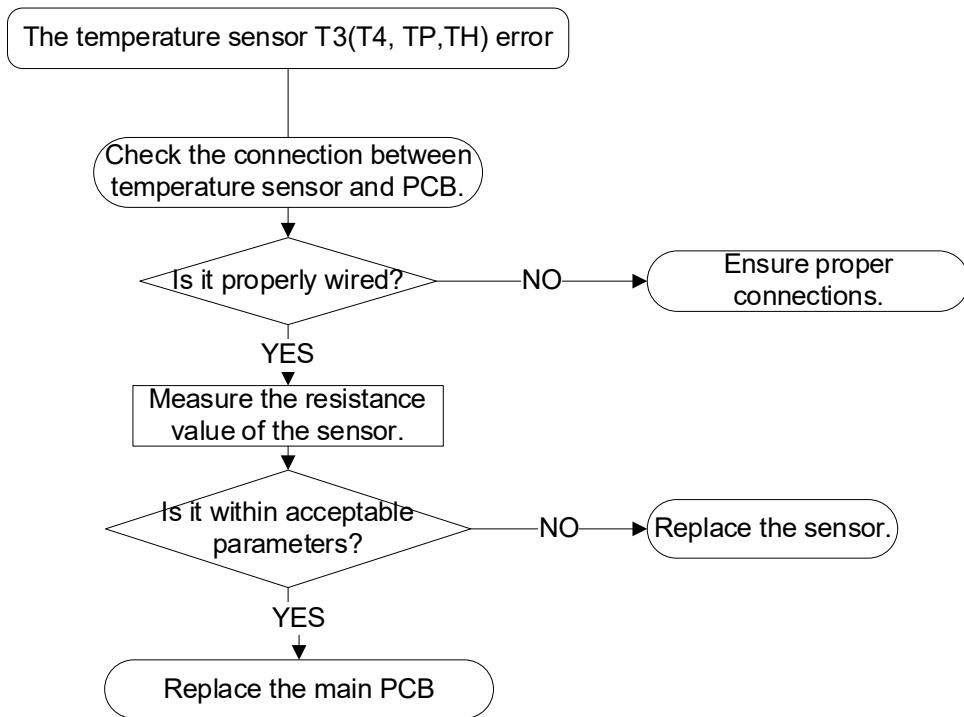

Notes: T3 is the evaporator temperature sensor.
T4 is the ambient temperature sensor.
TP is the compressor discharge temperature sensor.
TH is the compressor suction temperature sensor:

EH5U, EH5L, EH5N

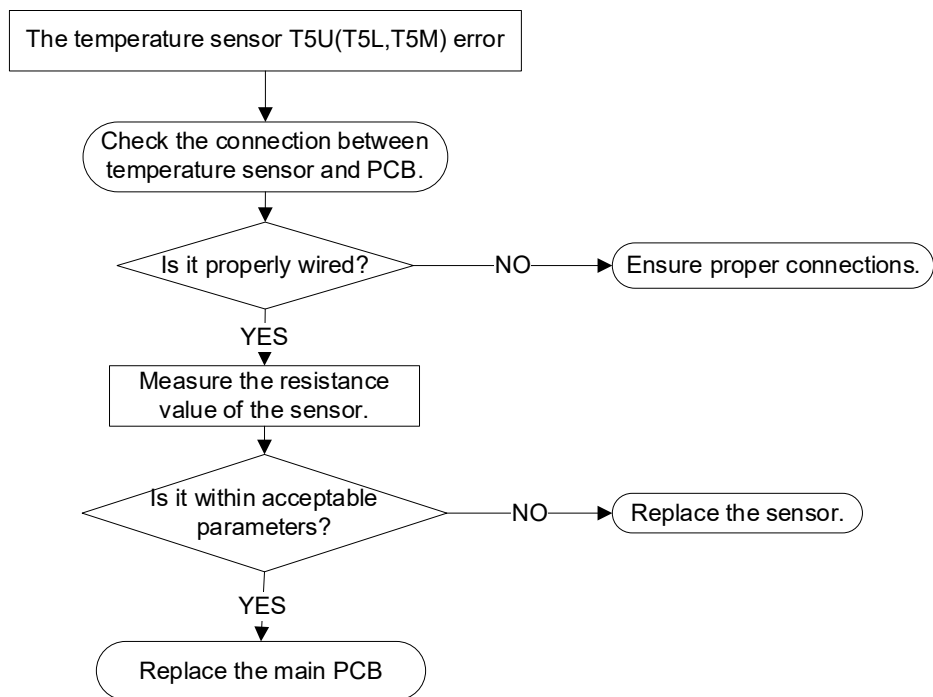

Notes:

T5U is the upper water temperature sensor.

T5L is the lower water temperature sensor.

T5M is solar temperature sensor.

EH5d

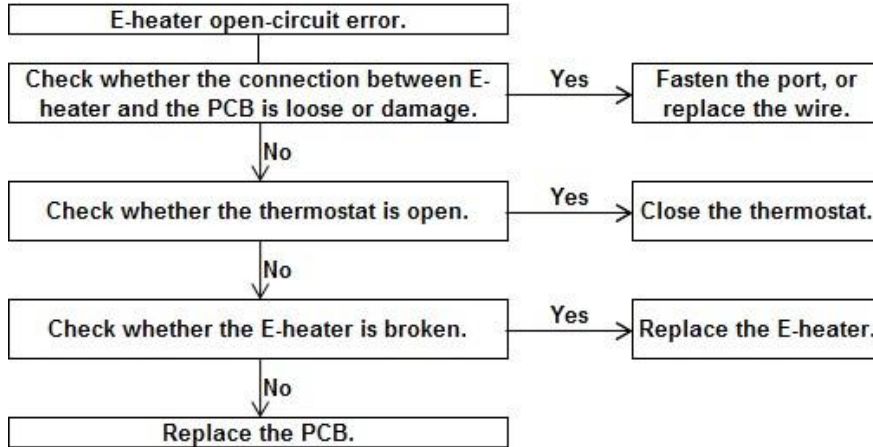

Notes:

E-heater open-circuit error means that IEH (Current difference E-heater on and off) <2A.

PHdH

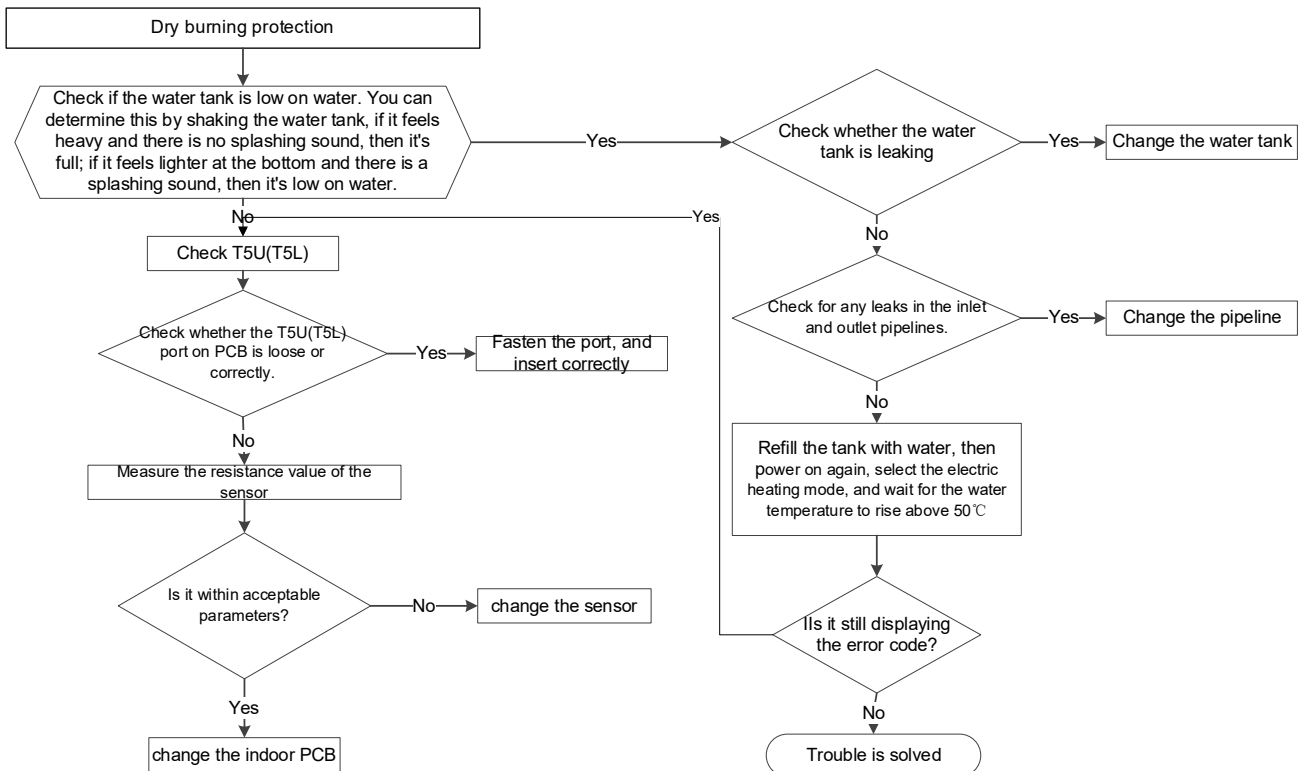

EHEA

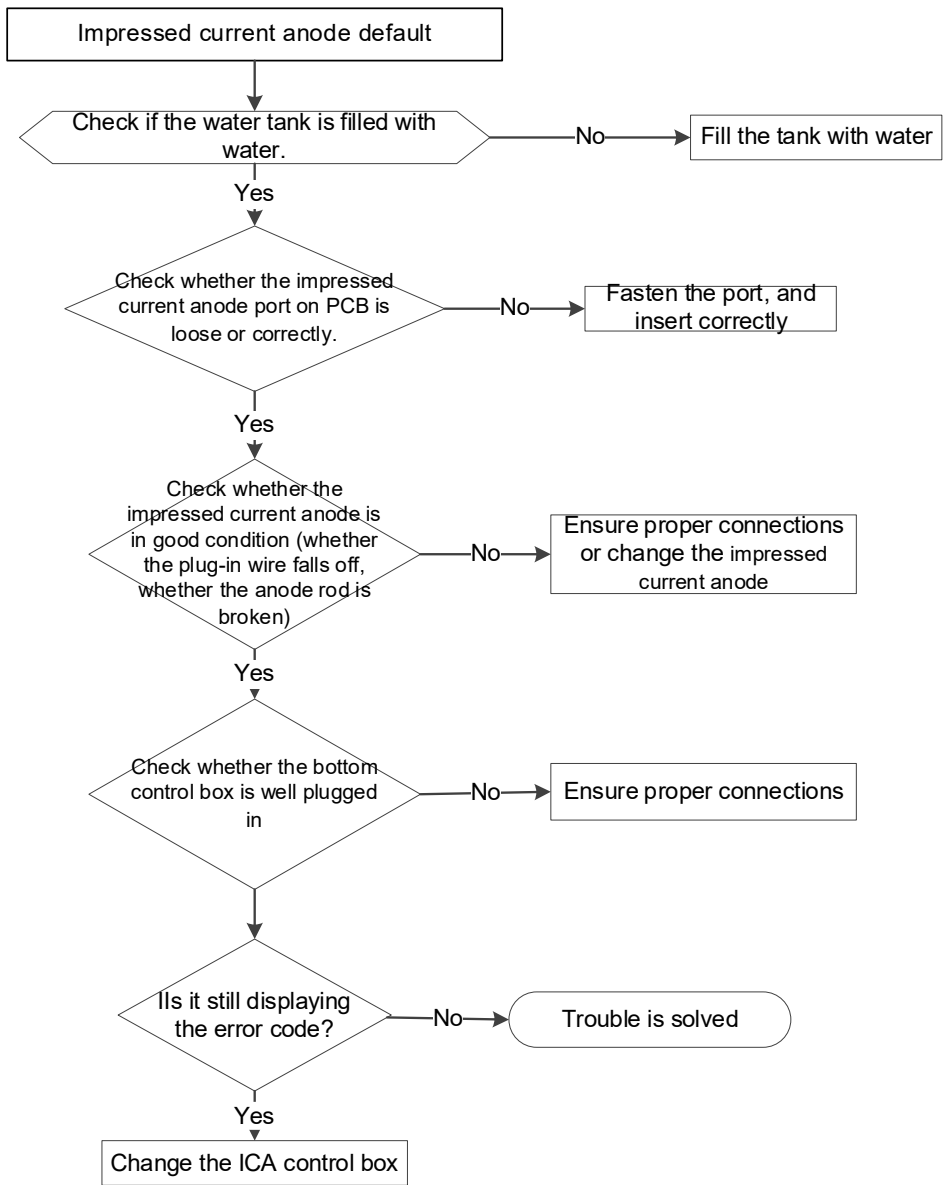

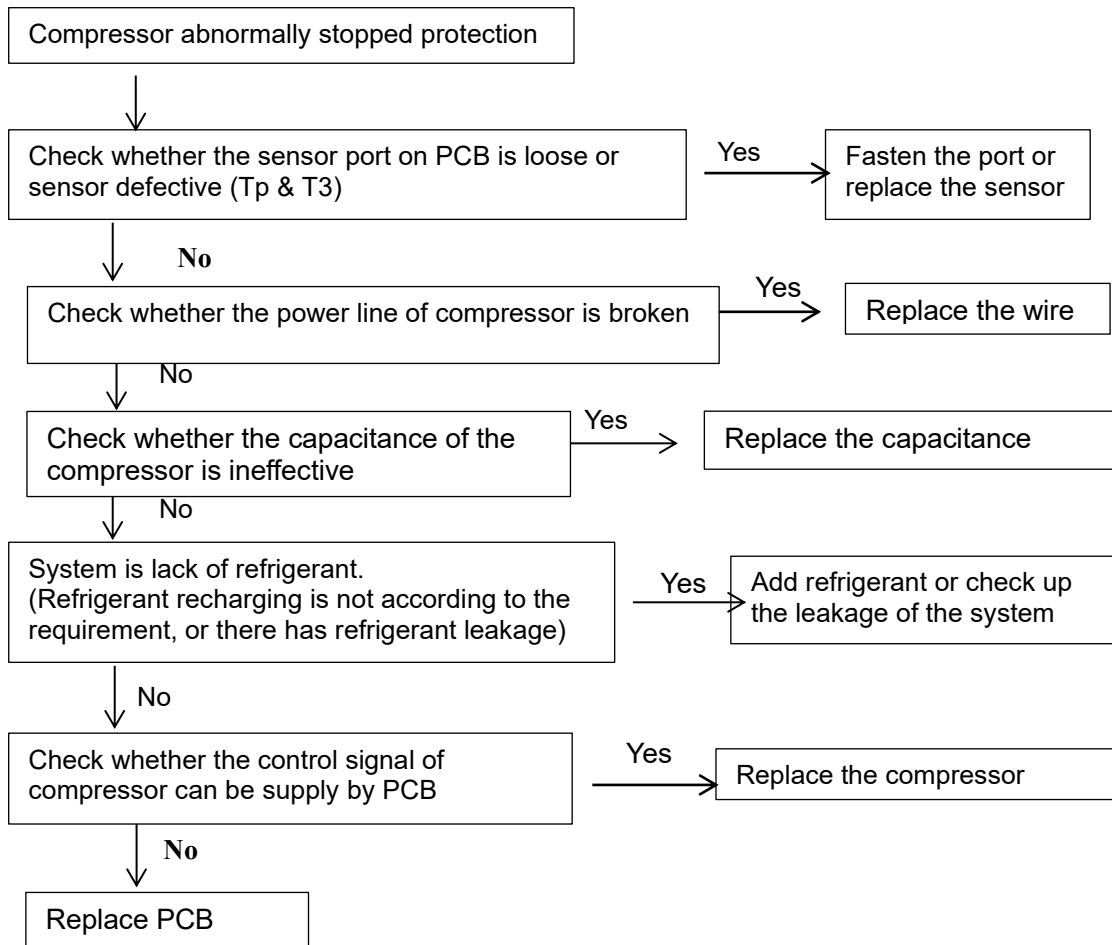

Notes:

The discharge temperature is not so higher than evaporator temperature after compressor running a term..

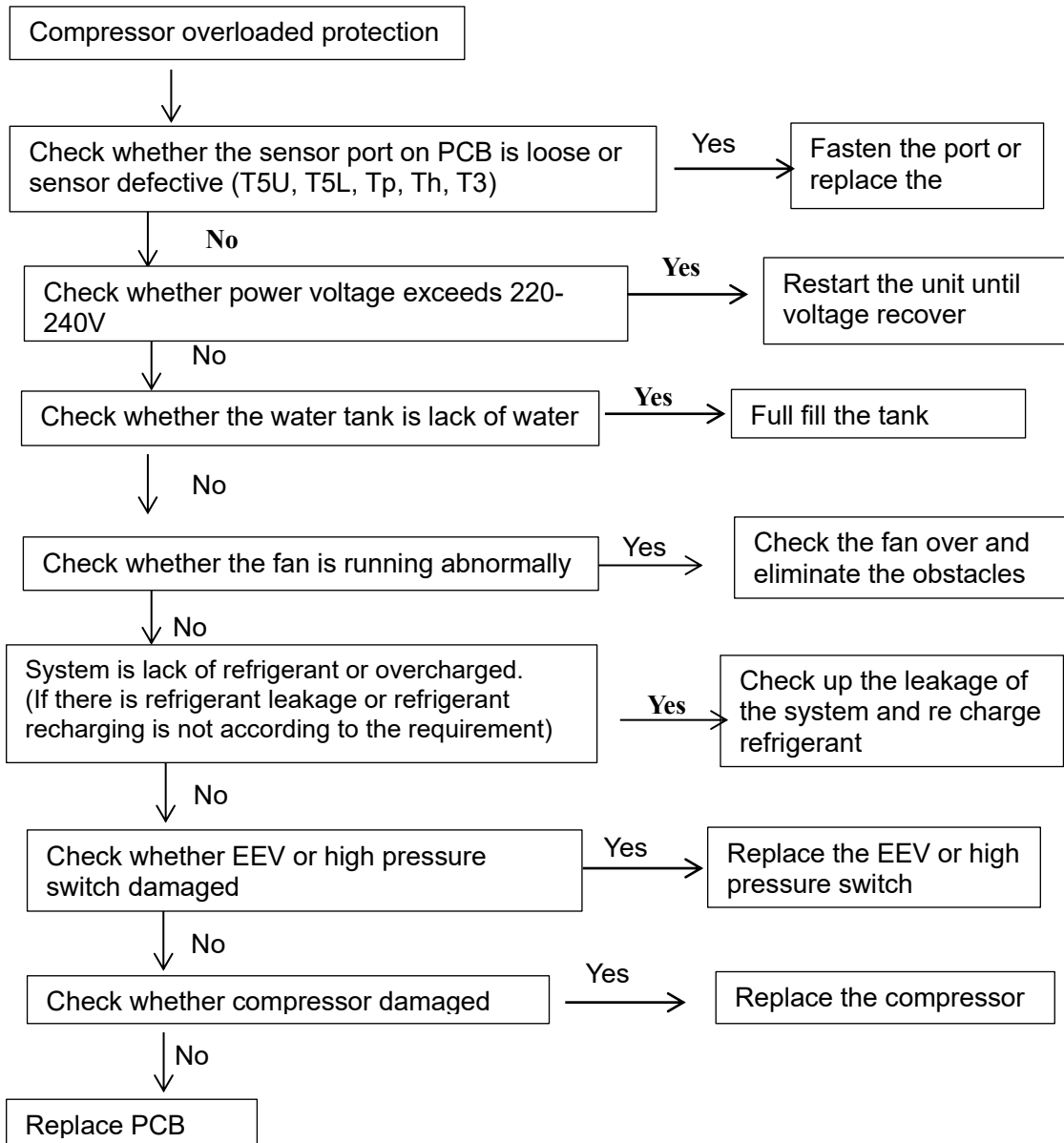

Notes:

10 s after compressor startup, current checking starts,

1) Only compressor running, if it is >6A, the compressor will be stopped and protected

2) Compressor and E-heater running at the same time, if it is >15A, the compressor will be stopped and protected.

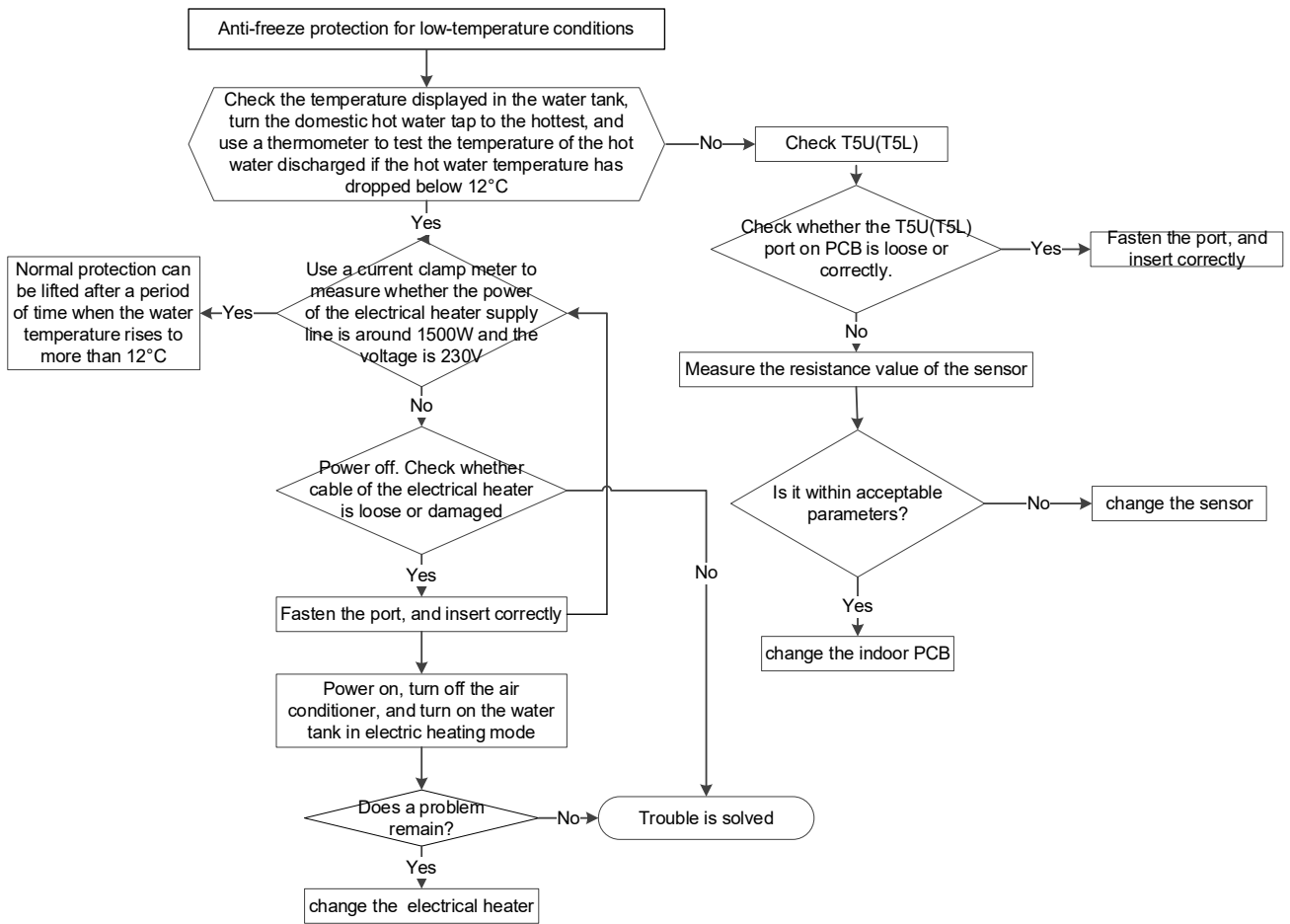

PC30

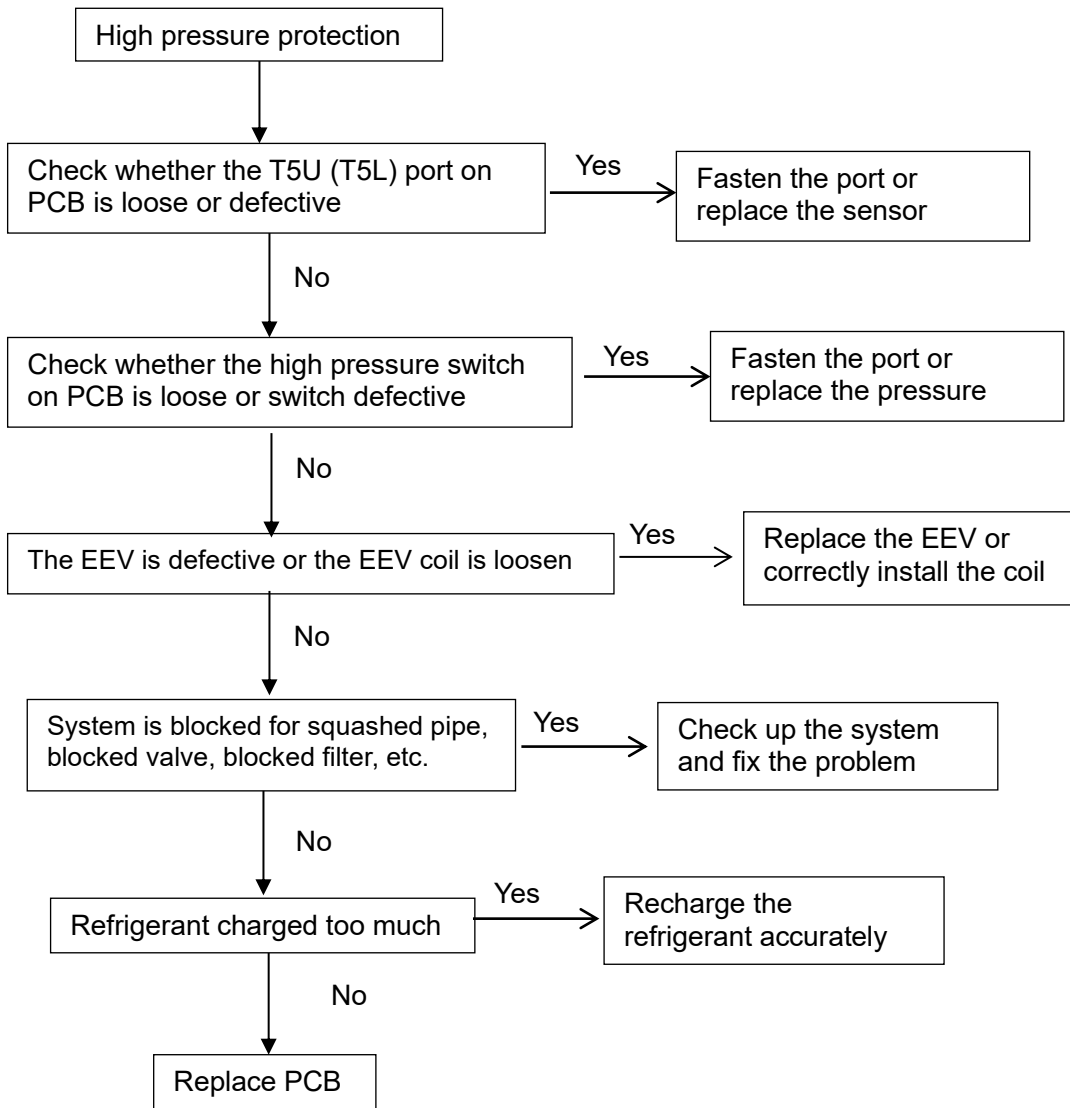

Notes:

When the discharge pressure of compressor is 3.0Mpa or higher, the protection switch will be triggered.

If the discharge pressure is down to 2.4MPa, the protection switch will be recovered.

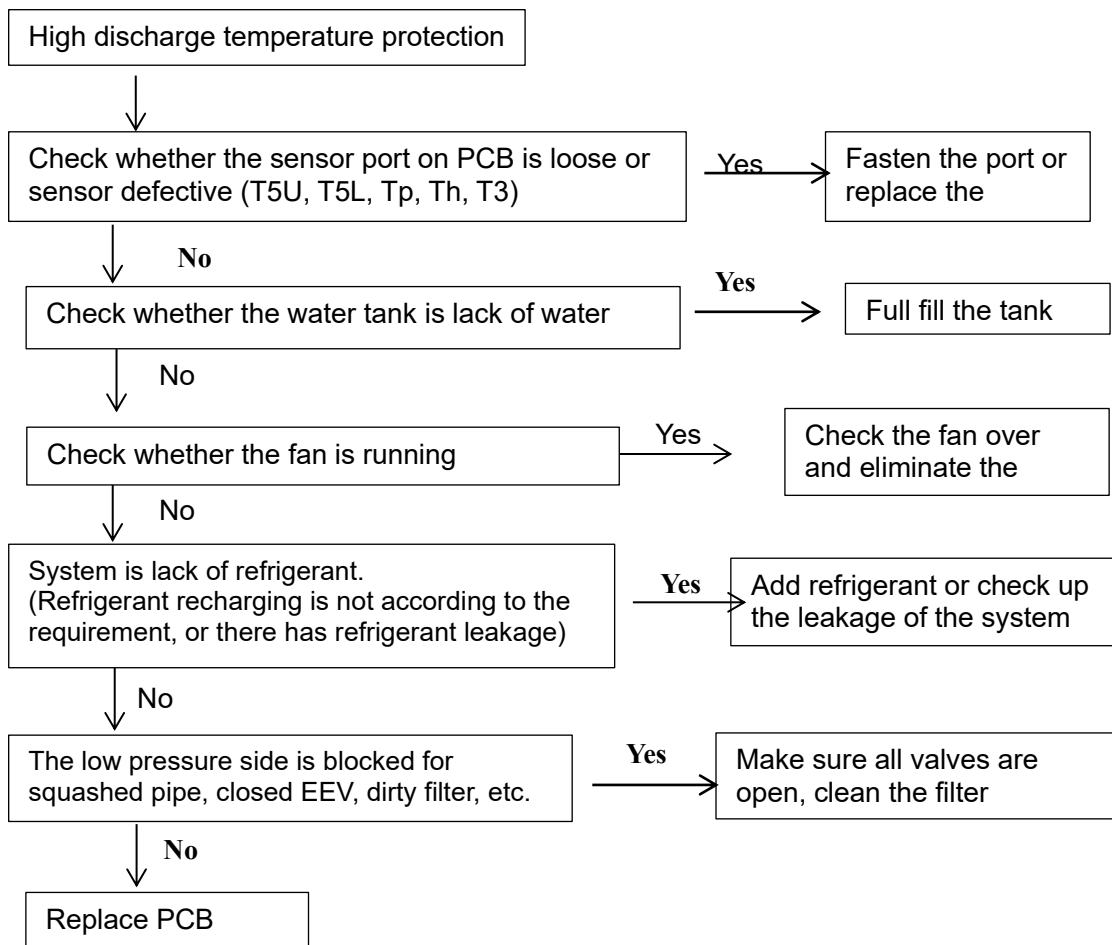

Notes:

When $T_p > 110^{\circ}\text{C}$, high discharge temperature protection P2 active.

When $T_p < 90^{\circ}\text{C}$, high discharge temperature protection P2 inactive.

PH9b

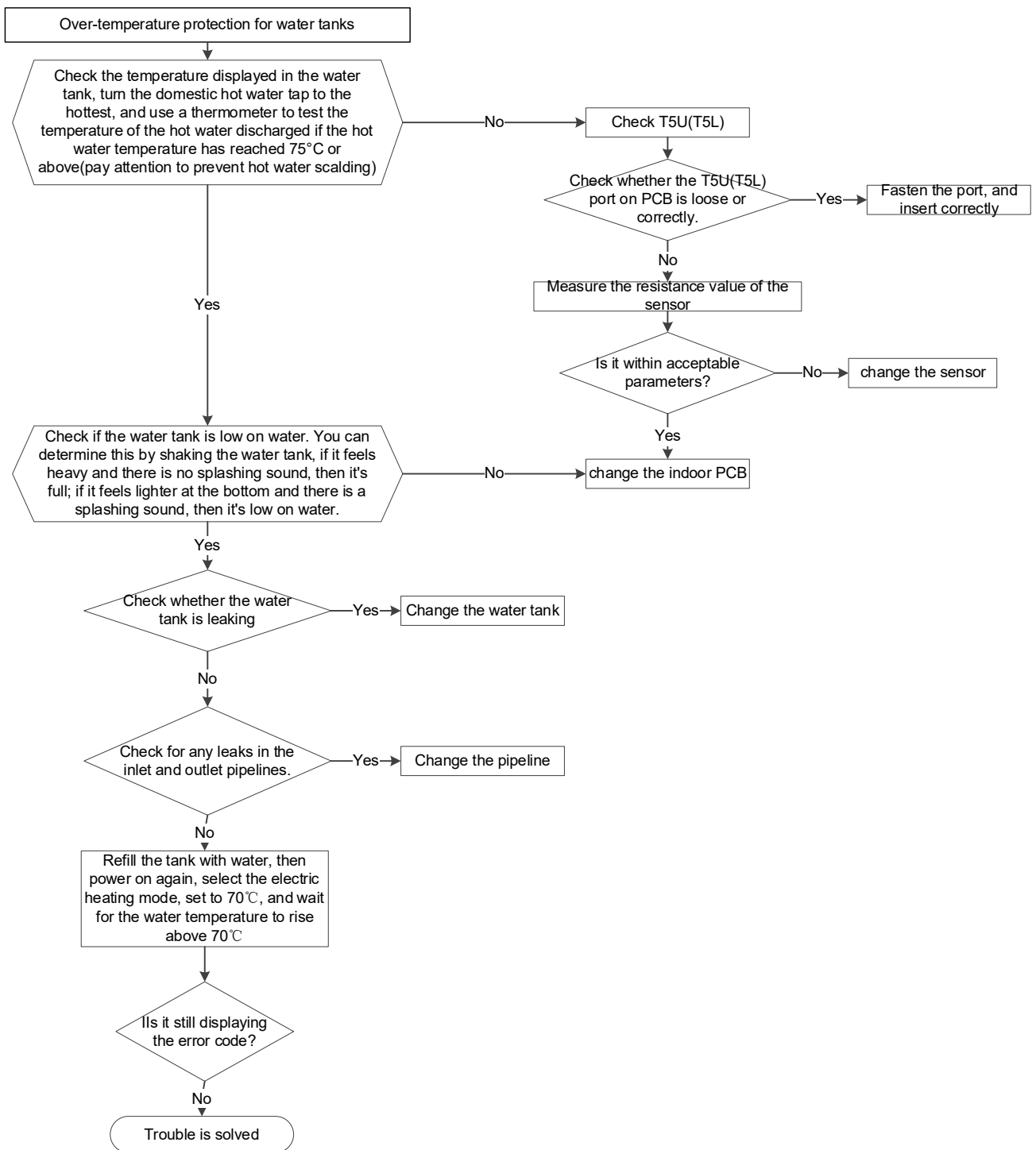

PH91

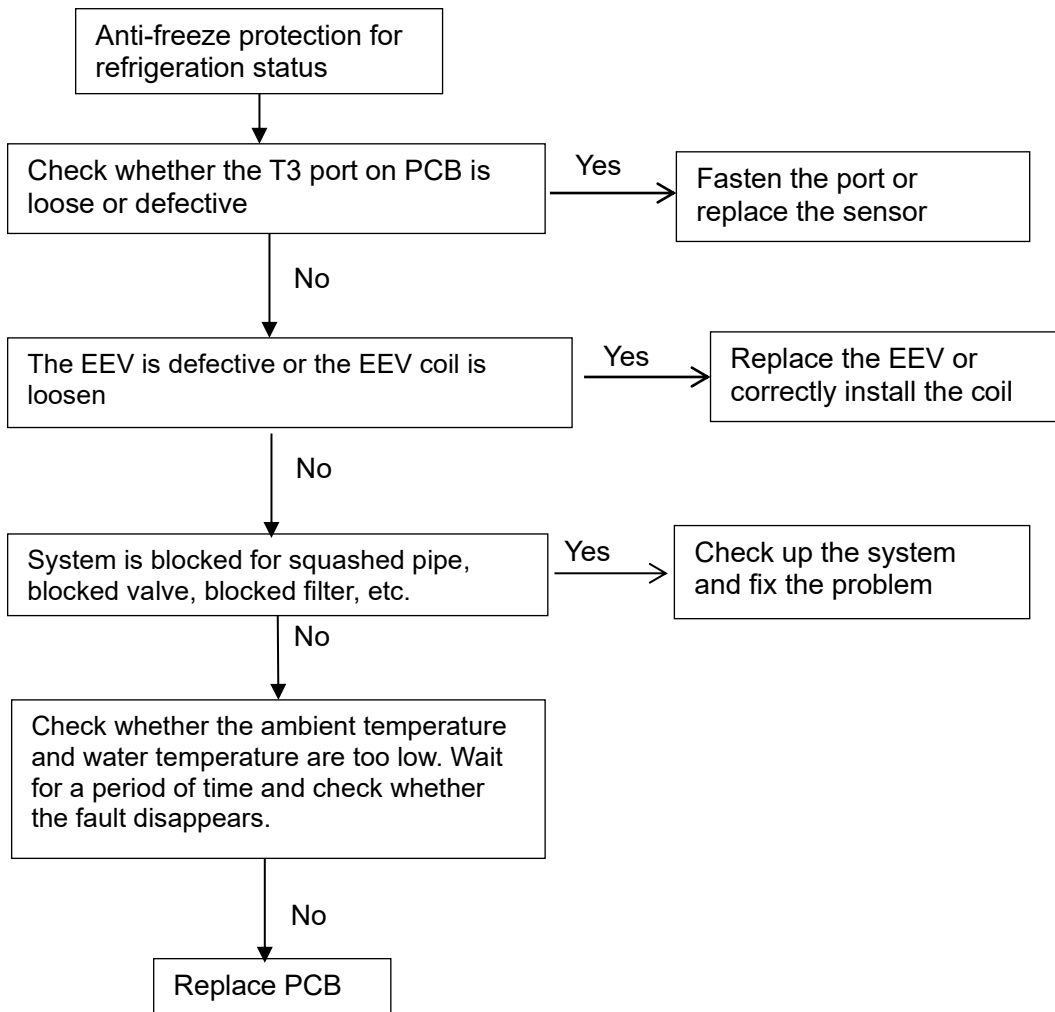

12. Function

Weekly Disinfect unction

Under disinfection mode, the unit will immediately start to heat water up to 70°C to kill the potential legionella bacteria

inside water tank.  icon will light on the display screen during disinfection. Unit will quit disinfection mode if water

temperature is higher than 70°C and extinguish  icon.



Vacation function

After pressing  button to select VACATION, unit will automatically heat water to 15°C for the purpose of energy saving during vacation days.

Remote shutdown function

Users can connect a switch. If the switch is closed, the unit will be stopped forcibly. If switch breaks, the unit can run normally according settings.

Query function

Pressing  for 1s then system running parameters will be shown one by one with following sequence by each pushing of  or  button.

No.	Hour low bit	Min. high bit	Min. low bit	Unit	Explanation
1	T	S	U	Temp./ °C	T5U
2	T	S	L	Temp./ °C	T5L
3	T	S	I	Temp./ °C	T5M
4		T	S	Temp./ °C	Heat pump stop temp
5		T	3	Temp./ °C	T3
6		T	4	Temp./ °C	T4
7		T	P	Temp./ °C	TP
8		T	H	Temp./ °C	Th
9		o	n		---
10	T	F	r		---
11		T	T	Temp./ °C	Disinfect temperature
12		L	o	Current	Compressor and electric heating current
13		F	o	Fan	AC Fan: 0: OFF 1: LOW 2: MID 3: HIGH Dc Fan: Real speed/10
14		E	o	Machine parameters	0~255

15	E	E	r		Electronic expansion valve opening
16	E	E	l		Compression mechanism hot water demand
17	P	U	P		Recirculation pump opening 0: OFF 1: ON
18		P	S		---
19		F	T		0: Ac Fan 1: Dc Fan
20		H	T		1(E-heater control type)
21		H	P		0(Compressor control type)
22	F	S	I		---
23	S	I	o		Tank capacity
24	P	4	P		Four-way valve status
25		U	U		0
26		U	I	Version	Host software version
27		U	2	Version	LCD panel software version
28		U	3	Version	000
29		U	4		0: One electric heater 1: Two electric heaters
30		U	T		3
31	I	E	r		Last error code
32	2	E	r		Previous 1st error or protection code
33	3	E	r		Previous 2nd error or protection cod
34	H	H	H		Maintenance time
35	T	L	F		Target temperature
36	E	n	d		END sign

Parameter setting

Long press  for 3 seconds, to enter the engineering mode and reset the parameters.



Code	Definition	Default	Setting instruction	Code	Definition	Default	Setting instruction
F 01	Unit conversion (APP does not have this function. Not recommended to modify)	0	0-Centigrade; 1-Fahrenheit;	F 24 F 25	--	--	--
F 02	Maintenance reminder function	1	0-Off; 1-On	F 26	Set time for weekly disinfect (minute)	0	Step size: 1; Set range: 0-59; Unit: min
F 03	Set time for maintenance reminder	365	Step size 10 (long press), Step size 1 (short press), Set range:30-365, unit: day	F 27	Electric heater forced compensation function (ECO mode, not recommended to modify)	Model 1:0 Model 2:1	0-Off; 1-On;
F 04	Reset maintenance reminder	0	0-No; 1-Yes	F 28 F 29	--	--	--
F 05	Clear error code	0	0-No; 1-Yes	F 30	Automatic backlight	1	0-Off, (all the time); 1-On, (normal mode)
F 06	The electric heater (for internal use only)	1	0-Off (the electrical heater is deactivated and will not the turn on during heating time); 1-On (the electrical heater is activated and will not the turn on during heating time according to the need);	F 31	Electric heater works in an integrated solar thermal system (solar only)	1	valid when F 32 = 4 0-Off; 1-On;
F 07	Weekly disinfect function	0	0-Off; 1-On	F 32	Integrated solar thermal system solution (solar only)	0	0-No Integrated solar thermal system 1-solution 1; 2-solution 2; 3-solution 3; 4-solution 4;
F 08	Set operating temperature of the electric heater (Not recommended to modify);	5	Step size 1, Set range: -5-5, unit: °C	F 33	--	--	--
F 09	Set start time for weekly disinfect (hour)	23	Step size 1, Set range:0-23, unit: h	F 34	Set key tone (buzz)	0	0-with buzz 1-no buzz
F 10	Smart test mode type (for internal test use only)	0	0- With reference period 1- no reference period, mode 1; 2- no reference period, mode 2;	F 35	Auto-child lock (Without button operation in 1 minute)	0	0-Off; 1-On;

F 11	Setpoint temperature for vacation mode	15	Step size 1, (10-20) unit: °C	F 36	Set temp difference (if the difference between the temperature detected by lower temperature sensor T5L and setting temperature is bigger than this set value, the HP will operate)	Model 1: 9 Model 2: 8	Step size: 1 Set range: 2-20; Unit: °C
F 12	Set fan speed for ventilation function(optional)	0	0-off (turn off ventilation function); 1-low fan speed; 2-middle fan speed; 3-high fan speed;	F 37 F 38 F 39	--	--	--
F 13	--	--	--	F 40	ESP setting	1	0-0-20pa; 1-20-40pa; 2-40-60pa; 3-60-80pa;
F 14	Set time for electric heater forced compensation (valid when F27 = 1. Not recommended to modify)	Model 1: 60 Model 2: 840	Model 1: Step size 10, Set range: 10-300; unit: min Model 2: Step size 10, Set range: 10-1500; unit: min	F 41	Set temp difference for starting the circulating water pump (solar only)	13	Step size: 1; Set range: 5-20; Unit: °C
F 15	Burned protection function (for internal use only)	1	0-Off; 1-On	F 42	Set temp difference for stopping the circulating water pump (solar only)	5	Step size: 1; Set range: 2-15; Unit: °C
F 16	Current detection function (for internal use only)	1	0-Off; 1-On	F 43	After the circulating water pump starts working, the time for detecting the water temperature rise is not measured. (solar only)	20	Step size: 1; Set range: 0-60; Unit: min
F 17	Setpoint temperature for weekly disinfect	Model 1: 70 Model 2: 65	Step size 1, Set range:60-70; unit: °C	F 44 F 45 F 46	--	--	--
F 18	Modify setpoint temperature maximum value (Not recommended to modify)	70	Step size 1, Set range:65-70; unit: °C				
F 19 F 20 F 22	--	--	--				
F 21	Set mod bus communication address	1	Step size: 1 Set range: 1-20				
F 23	Restore factory settings	0	0-No; 1-Yes				

13. Operation

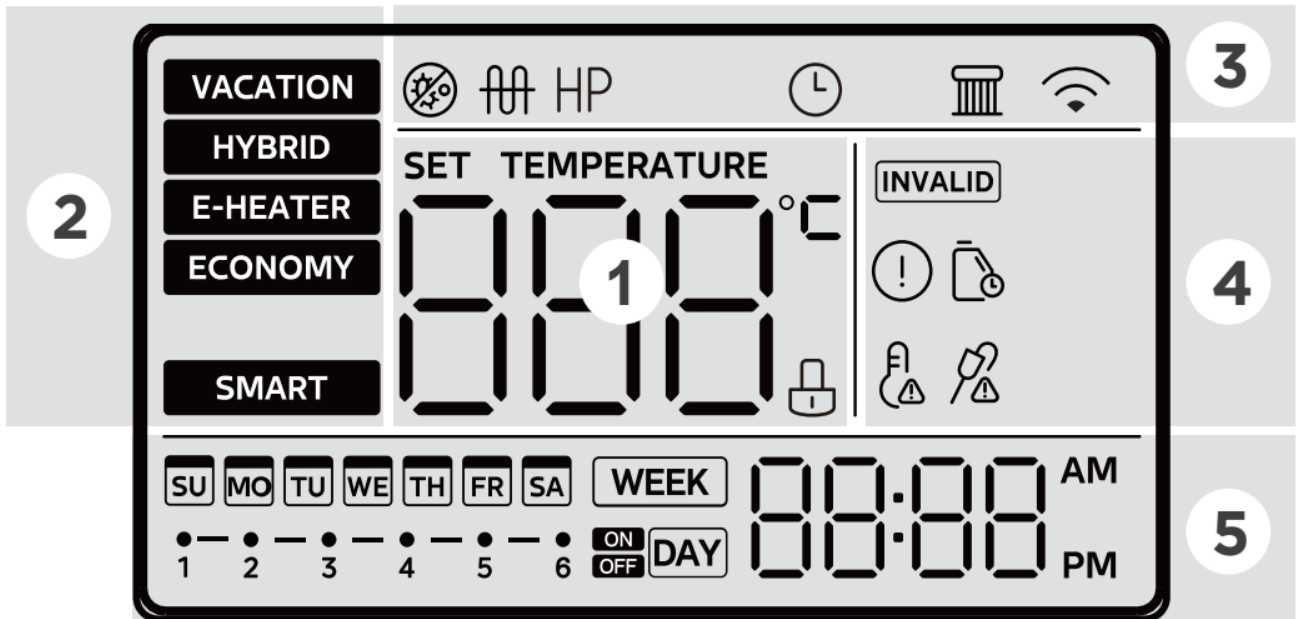
13.1 Display explanation



Area	Icon	Description
1 Information		<p>000 will be lighted if screen is unlocked.</p> <p>It shows water temperature on normal; It shows setting temperature on setting process; It shows remaining vacation days on vacation mode; It shows unit setting/running parameters, error/protection code on querying.</p>
	SET TEMPERATURE	The icon lights up when the water temperature is being set.
		<p>Child lock: If buttons are locked, the icon will be lightened, otherwise it will be turned off.</p>
2 Mode	<p>VACATION</p>	<p>VACATION MODE: For the vacation mode, the water temperature will be set at 15°C to keep a low energy consumption while preventing freezing in the tank.</p>
	<p>HYBRID</p>	<p>HYBRID MODE: When the ambient temperature is above 5 ° C, it is executed in eco mode. When the ambient temperature is 0-5 ° C, the e-heater is turned on after the heat pump works for 1 hour. When the ambient temperature is below 0 ° C, it is executed in e-heater mode.</p>
	<p>E-HEATER</p>	<p>E-HEATER MODE: When there is a demand for heat, the heat pump and the E-heater running at the same time if there are heat pump working conditions.</p>
	<p>ECONOMY</p>	<p>ECONOMY MODE: It is recommended to use this mode of operation whenever possible, as it saves more energy. The heat pump unit heats up to the maximum water temperature achievable at that inlet air temperature, before turning on the e-heater for heating, the heat pump and the electrical heater will not be turned on at the same time.</p>
	<p>SMART</p>	<p>SMART MODE The smart mode will record the user's hot water usage habits in the past 7 days, heat the water in advance according to the user's water consumption time, and stay on standby(do not heat the water) at other times. (It is recommended that the user set this mode after 7 days of normal operation of the unit, so as to avoid the machine failing to record complete user habits and affecting the use experience)</p>

Area	Icon	Description
3 Function		It will be lighted when the disinfection process is active.
		E-heater: It will light up when electrical heater is running, otherwise it will be off. NOTE: When the operating conditions are not met to turn on the electrical heater, the corresponding icon will briefly light up and then goes off.
		Heat pump icon: When the heat pump (compressor) is operating and producing hot water, the icon lights up.
		The icon lights up when the clock is being set.
		Wireless: 📶 will be light up when Wireless is connected; 📶 will be off when Wireless is not connected; 📶 will flash with 2Hz frequency when setting Wireless.
		Solar pump icon: When the solar pump is operating, the icon lights up.
4 Warning		When any key is invalid, this icon will flash 3 sec.
		Error: It will be lightened when unit is under protection/error.
		It flashes to remind the user to maintain the water tank. If you do not need maintenance reminders, you can enter engineering mode channel 2 to disable this function, or engineering mode 4 to reset the maintenance reminder time, the default maintenance reminder time is 365 days.
		High temp. alarm If water temp is higher than 50°C, the warning light will turn on, when temperature decreases then warning light will turn off.
		Impressed current anode reminder (optional): It will be lightened when the impressed current anode has a default.
5 Timer		Time and clock setting Displays the current time or the time programmed during the programming of the time schedule.
		Schedule settings There is an option to set a schedule on weekly or daily basis. If no schedule is set, the corresponding part of the screen remains blank. Otherwise "WEEK" or "DAY" is displayed accordingly. During setting the corresponding icon ("WEEK" or "DAY") is flashing.

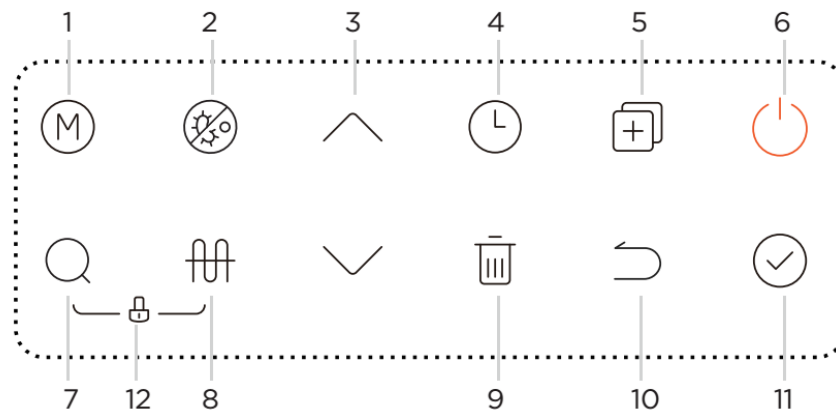

13.2 Button explanation







NOTE:

Any pressing of button is effective only under button and display unlocked state. When the operating conditions are not met to turn on this function, the corresponding icon on the wire controller lights up briefly and then turns off.

1) Weekly disinfect function

In disinfection mode, unit immediately start to heat water up to 70°C to kill the potential legionella bacteria inside water of tank , icon will light on the display screen while disinfection mode is working. Unit will quit disinfection if water temperature is higher than 70°C and light off  icon.







2) Vacation function







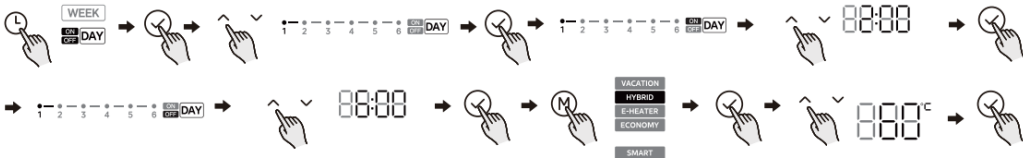



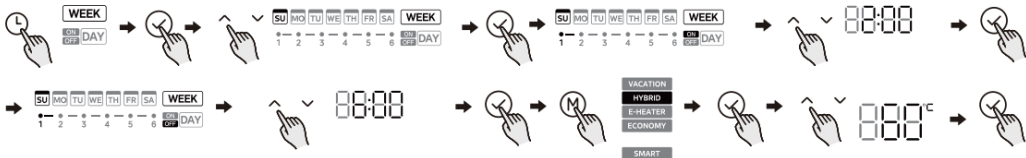











Press  to select VACATION, then unit will automatically heat water to 15°C for the purpose of energy saving during vacation days. Press   to adjust vacation days and press  to make the setting effective.









3) Remote shutdown function

If the switch is turned off, the unit will be stopped forcibly. If the switch breaks, the unit can run normally according settings.

Detailed operating instructions

No	Icon	Description
1		<p>MODE Press this button to switch mode</p> <p style="text-align: center;"> HYBRID ▶ E-HEATER ▶ ECONOMY ▶ SMART ▶ VACATION </p>
2		<p>Click the button to force the turn on of disinfection function.</p>
3		<p>UP & DOWN If screen is unlocked, press ^/∨ to adjust corresponding value. While setting temperature/timer/vacation days, press more than 1s to change the value continuously. Press Ⓞ to make the setting effective. On querying, use the buttons to select check items.</p>
4		<p>Daily timer setting:</p>  <p>• While setting the [on/off time], you can restore to the default value (displaying---) by pressing .</p>

		<ul style="list-style-type: none"> • If there is a conflict between two time periods, settings of the later one will be valid, and the earlier one will be canceled and turn back to default values. • If you adjust a value again after all the setting is completed, then the settings after the adjustment period will be canceled and turn back to default values. • You can enter the timer setting in both power-on and power-off state. <p>Weekly timer setting:</p>  <ul style="list-style-type: none"> • To copy the settings of one day to other days: While in the day selection, press  to copy a base day's settings, then select other days by pressing  again (the status will become fast flashing). Press  to confirm the operation and the settings will be copied to the selected days. <p>Note: When setting the daily/weekly timer, model "VACATION" and "SMART" can not be selected.</p>
<p>5</p>	  <p>ENGINEERING MODE only for qualified person</p>	<p>COPY / ENGINEERING MODE</p> <p>In the main screen, press and hold  for 3 seconds to enter the engineering mode. Use  to switch the inspection channel, and the attribute value of the channel will be displayed. You can modify the parameter setting with , and after adjusting, press  to make the setting effective. Press  to return to the channel selection screen.</p> <p>After 30 seconds from the last operation, or by pressing the return key or the on/off key, you can directly exit the engineering mode.</p> <p>CAUTION</p> <ul style="list-style-type: none"> • It is strictly prohibited for the customer to change the parameter settings of the channels in the engineering mode without authorization to avoid affecting the normal operation of the unit or causing damage to the unit.
<p>6</p>		<p>POWER ON/OFF</p> <p>Press the button to start / stop the unit.</p>
<p>7</p>		<p>SEARCH / QUERY MODE</p> <ul style="list-style-type: none"> • In the main screen, press and hold  for 1 second to enter the query mode. Use  to switch the spot check channel, and the attribute value of the channel will be displayed, please refer to the following table for details. • After 30 seconds from the last operation, or by pressing  or , you can directly exit the query mode. • Query mode can be entered in both power-on and power-off state.
<p>8</p>		<p>If screen is unlocked, press this button to manually activate E-HEATER.</p>
<p>9</p>		<p>DELETE</p> <p>This key is used to cancel all settings in progress and exit the setting state. When the wireless connection is working, long press  for more than 8s to exit Wireless connection.</p>
<p>10</p>		<p>RETURN</p> <p>Press the button to return to the previous setting or main screen.</p>
<p>11</p>		<p>CONFIRM</p> <p>If screen and buttons are unlocked, press it to upload setting parameters after setting any parameter.</p>

<p>12</p> 	<p>CHILD LOCK</p> <ul style="list-style-type: none"> • In the user interface, long press the key combination for 2 seconds to enter the child lock state; • In the state of child lock, long press the key combination again for 2 seconds to release the child lock state; • In the locked state, there will be an icon  next to the water temperature display. • When there is no operation of any button for 60 seconds, button will be locked. Press  +  simultaneously will be unlocked.
<p>13</p> 	<p>Connecting the wireless function</p> <ul style="list-style-type: none"> • In the user interface, long press  for 3 seconds to enter the AP wireless network mode, there will be a  in the upper right corner of the controller display. At this time, enter the APP, select the category of air water heater, choose the correct model, and then network according to the APP prompts, and after the network is completed, the wireless icon  will be always on; • Wireless matching can last up to 8 minutes, after 8 minutes, if the matching is not successful, the wireless icon will go out; • Long press  for 8 seconds in the user interface to reset the wireless function; It can be set in both power on and power off state.

Use Your Appliance with the Smart Home App

Ensure that your mobile phone is connected to the home wireless network, the 2.4GHz band wireless signal is enabled on your wireless router and you know the network password.

Turn on Bluetooth on your phone and the device must also be powered up. Please be aware that in some locations the wifi signal could be poor and not allow the connection. A signal amplifier could be needed.

Step 1: Download the Smart Home app

Scan the QR code below to download the Smart Home app from app store or search for it directly on the Google Play Store or Apple's App Store.

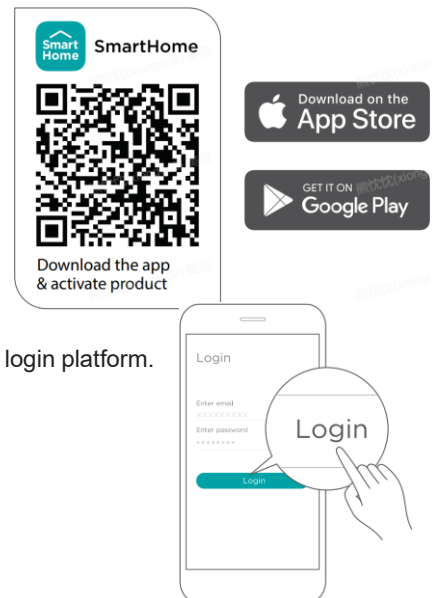

Step 2: Log in

Open the Smart Home app. Log in directly if you have an existing Smart Home account or create a new account. Alternatively, you can also use a 3rd party login platform.

Step 3: Connecting the device

- 1) When you log in, you may see the message "Smart devices discovered nearby". Tap to add your device.
- 2) If no such message appears, proceed as follows: Tap on "+" and select your device in the list of nearby available devices.
If your device is not listed, please add your device manually, first selecting the device category e.g. Water Heater.
- 3) Follow the steps in the app to connect your device to the wireless network. If your device fails to connect, follow the additional instructions in the app.

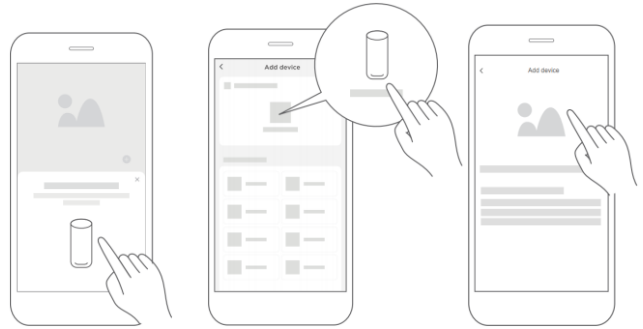

Step 4: Controlling the device

After pairing successfully, a card will be created for the device in the Smart Home app.

Shortcuts for basic functions will appear on the card such as changing the humidity or switching the device on or off.

Tapping on the card, will reveal additional features and settings. The actual UI design may look different from examples due to app updates

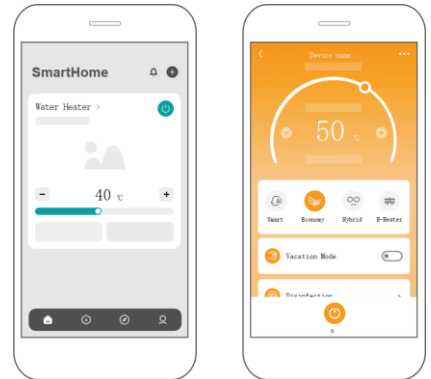

14. Accessories

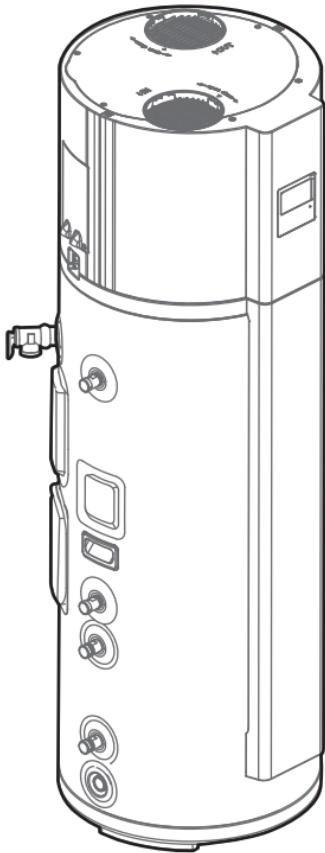

 One way valve

 Air duct connector

 Filter

 Safety & User's manual

 condensate drain pipe

or
 Fixing strip



15. Resistance characteristic of temperature sensor

➤ Resistance characteristic of ambient Temp., pipe Temp. and suction Temp. sensor.

Temp. (°C)	Resistance value (kΩ)	Temp. (°C)	Resistance value (kΩ)	Temp. (°C)	Resistance value (kΩ)	Temp. (°C)	Resistance value (kΩ)
-20	115.266	20	12.6431	60	2.35774	100	0.62973
-19	108.146	21	12.0561	61	2.27249	101	0.61148
-18	101.517	22	11.5	62	2.19073	102	0.59386
-17	96.3423	23	10.9731	63	2.11241	103	0.57683
-16	89.5865	24	10.4736	64	2.03732	104	0.56038
-15	84.219	25	10	65	1.96532	105	0.54448
-14	79.311	26	9.55074	66	1.89627	106	0.52912
-13	74.536	27	9.12445	67	1.83003	107	0.51426
-12	70.1698	28	8.71983	68	1.76647	108	0.49989
-11	66.0898	29	8.33566	69	1.70547	109	0.486
-10	62.2756	30	7.97078	70	1.64691	110	0.47256
-9	58.7079	31	7.62411	71	1.59068	111	0.45957
-8	56.3694	32	7.29464	72	1.53668	112	0.44699
-7	52.2438	33	6.98142	73	1.48481	113	0.43482
-6	49.3161	34	6.68355	74	1.43498	114	0.42304
-5	46.5725	35	6.40021	75	1.38703	115	0.41164
-4	44	36	6.13059	76	1.34105	116	0.4006
-3	41.5878	37	5.87359	77	1.29078	117	0.38991
-2	39.8239	38	5.62961	78	1.25423	118	0.37956
-1	37.1988	39	5.39689	79	1.2133	119	0.36954
0	35.2024	40	5.17519	80	1.17393	120	0.35982
1	33.3269	41	4.96392	81	1.13604	121	0.35042
2	31.5635	42	4.76253	82	1.09958	122	0.3413
3	29.9058	43	4.5705	83	1.06448	123	0.33246
4	28.3459	44	4.38736	84	1.03069	124	0.3239
5	26.8778	45	4.21263	85	0.99815	125	0.31559
6	25.4954	46	4.04589	86	0.96681	126	0.30754
7	24.1932	47	3.88673	87	0.93662	127	0.29974
8	22.5662	48	3.73476	88	0.90753	128	0.29216
9	21.8094	49	3.58962	89	0.8795	129	0.28482
10	20.7184	50	3.45097	90	0.85248	130	0.2777
11	19.6891	51	3.31847	91	0.82643	131	0.27078
12	18.7177	52	3.19183	92	0.80132	132	0.26408
13	17.8005	53	3.07075	93	0.77709	133	0.25757
14	16.9341	54	2.95896	94	0.75373	134	0.25125
15	16.1156	55	2.84421	95	0.73119	135	0.24512
16	15.3418	56	2.73823	96	0.70944	136	0.23916
17	14.6181	57	2.63682	97	0.68844	137	0.23338
18	13.918	58	2.53973	98	0.66818	138	0.22776
19	13.2631	59	2.44677	99	0.64862	139	0.22231

➤ Resistance characteristic of discharge temperature sensor

Temp. (°C)	Resistance value (kΩ)	Temp. (°C)	Resistance value (kΩ)	Temp. (°C)	Resistance value (kΩ)	Temp. (°C)	Resistance value (kΩ)
-20	542.7	20	68.66	60	13.59	100	3.702
-19	511.9	21	65.62	61	13.11	101	3.595
-18	483	22	62.73	62	12.65	102	3.492
-17	455.9	23	59.98	63	12.21	103	3.392
-16	430.5	24	57.37	64	11.79	104	3.296
-15	406.7	25	54.89	65	11.38	105	3.203
-14	384.3	26	52.53	66	10.99	106	3.113
-13	363.3	27	50.28	67	10.61	107	3.025
-12	343.6	28	48.14	68	10.25	108	2.941
-11	325.1	29	46.11	69	9.902	109	2.86
-10	307.7	30	44.17	70	9.569	110	2.781
-9	291.3	31	42.33	71	9.248	111	2.704
-8	275.9	32	40.57	72	8.94	112	2.63
-7	261.4	33	38.89	73	8.643	113	2.559
-6	247.8	34	37.3	74	8.358	114	2.489
-5	234.9	35	35.78	75	8.084	115	2.422
-4	222.8	36	34.32	76	7.82	116	2.357
-3	211.4	37	32.94	77	7.566	117	2.294
-2	200.7	38	31.62	78	7.321	118	2.233
-1	190.5	39	30.36	79	7.086	119	2.174
0	180.9	40	29.15	80	6.859	120	2.117
1	171.9	41	28	81	6.641	121	2.061
2	163.3	42	26.9	82	6.43	122	2.007
3	155.2	43	25.86	83	6.228	123	1.955
4	147.6	44	24.85	84	6.033	124	1.905
5	140.4	45	23.89	85	5.844	125	1.856
6	133.5	46	22.89	86	5.663	126	1.808
7	127.1	47	22.1	87	5.488	127	1.762
8	121	48	21.26	88	5.32	128	1.717
9	115.2	49	20.46	89	5.157	129	1.674
10	109.8	50	19.69	90	5	130	1.632
11	104.6	51	18.96	91	4.849		
12	99.69	52	18.26	92	4.703		
13	95.05	53	17.58	93	4.562		
14	90.66	54	16.94	94	4.426		
15	86.49	55	16.32	95	4.294	B(25/50)=3950K	
16	82.54	56	15.73	96	4.167		
17	78.79	57	15.16	97	4.045	R(90°C)=5KΩ+-3%	
18	75.24	58	14.62	98	3.927		
19	71.86	59	14.09	99	3.812		

➤ Resistance characteristic of water tank temperature sensor & solar temperature sensor

Temp. (°C)	Max. Resistance value (kΩ)	Normal Resistance value (kΩ)	Min. Resistance value (kΩ)	Temp. Tol. (°C)	
-30	965.72	867.29	778.18	-1.78	1.73
-29	907.28	815.80	732.88	-1.78	1.72
-28	852.73	767.68	690.49	-1.77	1.72
-27	801.77	722.68	650.80	-1.76	1.71
-26	754.12	680.54	613.59	-1.75	1.70
-25	709.53	641.07	578.70	-1.73	1.69
-24	667.79	604.08	545.95	-1.72	1.68
-23	628.70	569.39	515.21	-1.71	1.67
-22	592.07	536.85	486.34	-1.70	1.65
-21	557.76	506.33	459.22	-1.68	1.64
-20	525.60	477.69	433.75	-1.67	1.63
-19	495.45	450.81	409.82	-1.66	1.63
-18	467.19	425.59	387.34	-1.65	1.62
-17	440.70	401.91	366.21	-1.64	1.61
-16	415.86	379.69	346.36	-1.63	1.60
-15	392.57	358.83	327.70	-1.62	1.59
-14	370.72	339.24	310.16	-1.61	1.58
-13	350.23	320.85	293.66	-1.60	1.57
-12	331.00	303.56	278.16	-1.59	1.56
-11	312.95	287.33	263.57	-1.58	1.56
-10	296.00	272.06	249.84	-1.57	1.55
-9	280.08	257.71	236.92	-1.56	1.54
-8	265.12	244.21	224.75	-1.55	1.53
-7	251.06	231.51	213.28	-1.54	1.52
-6	237.84	219.55	202.48	-1.53	1.52
-5	225.40	208.28	192.29	-1.52	1.51
-4	213.69	197.67	182.69	-1.51	1.50
-3	202.66	187.66	173.62	-1.50	1.49
-2	192.27	178.22	165.05	-1.49	1.48
-1	182.47	168.31	156.96	-1.48	1.47
0	173.23	160.90	149.32	-1.47	1.46
1	164.51	152.96	142.09	-1.45	1.45
2	156.28	145.45	135.25	-1.44	1.44
3	148.50	138.35	128.78	-1.43	1.43
4	141.15	131.64	122.65	-1.42	1.41
5	134.21	125.28	116.85	-1.40	1.40
6	127.64	119.27	111.35	-1.39	1.39
7	121.43	113.58	106.14	-1.38	1.38
8	115.55	108.18	101.19	-1.37	1.37
9	109.98	103.07	96.507	-1.35	1.36

Temp. (°C)	Max. Resistance value (kΩ)	Normal Resistance value (kΩ)	Min. Resistance value (kΩ)	Temp. Tol. (°C)	
10	104.71	98.227	92.060	-1.34	1.34
11	99.722	93.634	87.839	-1.33	1.33
12	94.992	89.278	83.832	-1.31	1.32
13	90.510	85.146	80.028	-1.30	1.31
14	86.261	81.225	76.415	-1.28	1.29
15	82.232	77.504	72.983	-1.27	1.28
16	78.411	73.972	69.722	-1.26	1.27
17	74.787	70.619	66.623	-1.24	1.25
18	71.348	67.434	63.677	-1.23	1.24
19	68.085	64.409	60.876	-1.22	1.23
20	64.988	61.535	58.213	-1.20	1.22
21	62.047	58.804	55.680	-1.19	1.20
22	59.255	56.209	53.271	-1.17	1.19
23	56.604	53.742	50.978	-1.16	1.18
24	54.085	51.396	48.797	-1.15	1.17
25	51.691	49.165	46.720	-1.13	1.15
26	49.417	47.043	44.744	-1.12	1.14
27	47.255	45.025	42.861	-1.10	1.13
28	45.199	43.104	41.068	-1.09	1.11
29	43.245	41.276	39.361	-1.08	1.10
30	41.386	39.535	37.733	-1.06	1.09
31	39.617	37.878	36.183	-1.05	1.07
32	37.934	36.299	34.704	-1.04	1.06
33	36.331	34.796	33.295	-1.02	1.05
34	34.806	33.363	31.951	-1.01	1.03
35	33.353	31.977	30.668	-0.99	1.02
36	31.970	30.695	29.445	-0.98	1.01
37	30.651	29.453	28.277	-0.96	0.99
38	29.394	28.269	27.162	-0.95	0.98
39	28.196	27.139	26.098	-0.94	0.97
40	27.054	26.061	25.081	-0.92	0.95
41	25.964	25.031	24.110	-0.91	0.94
42	24.925	24.048	23.182	-0.89	0.92
43	23.933	23.109	22.294	-0.88	0.91
44	22.986	22.212	21.446	-0.86	0.89
45	22.081	21.355	20.635	-0.85	0.88
46	21.217	20.536	19.858	-0.83	0.86
47	20.392	19.752	19.116	-0.82	0.85
48	19.603	19.003	18.405	-0.80	0.83
49	18.849	18.286	17.724	-0.79	0.82

Temp. (°C)	Max. Resistance value (kΩ)	Normal Resistance value (kΩ)	Min. Resistance value (kΩ)	Temp. Tol. (°C)	
50	18.128	17.600	17.072	-0.77	0.80
51	17.465	16.943	16.423	-0.79	0.83
52	16.830	16.315	15.801	-0.82	0.85
53	16.221	15.713	15.207	-0.84	0.88
54	15.637	15.136	14.638	-0.87	0.90
55	15.077	14.583	14.093	-0.89	0.93
56	14.541	14.054	13.571	-0.92	0.95
57	14.026	13.546	13.071	-0.94	0.98
58	13.531	13.059	12.592	-0.97	1.00
59	13.057	12.592	12.133	-1.00	1.03
60	12.602	12.144	11.693	-1.02	1.05
61	12.165	11.715	11.271	-1.05	1.08
62	11.745	11.302	10.866	-1.07	1.10
63	11.342	10.906	10.478	-1.10	1.13
64	10.954	10.526	10.106	-1.13	1.15
65	10.582	10.161	9.7486	-1.15	1.18
66	10.224	9.8105	9.4056	-1.18	1.20
67	9.8794	9.4736	9.0762	-1.20	1.23
68	9.5484	9.1498	8.7600	-1.23	1.25
69	9.2301	8.8387	8.4562	-1.26	1.28
70	8.9239	8.5396	8.1645	-1.28	1.30
71	8.6293	8.2520	7.8841	-1.31	1.33
72	8.3458	7.9755	7.6147	-1.34	1.36
73	8.0729	7.7094	7.3557	-1.37	1.38
74	7.8102	7.4536	7.1068	-1.39	1.41
75	7.5573	7.2073	6.8674	-1.42	1.43
76	7.3137	6.9704	6.6372	-1.45	1.46
77	7.0791	6.7423	6.4157	-1.48	1.49
78	6.8532	6.5228	6.2027	-1.50	1.51
79	6.6354	6.3114	5.9977	-1.53	1.54
80	6.4256	6.1078	5.8005	-1.56	1.57
81	6.2234	5.9117	5.6106	-1.59	1.59
82	6.0285	5.7228	5.4278	-1.62	1.62
83	5.8405	5.5409	5.2518	-1.65	1.65
84	5.6593	5.3655	5.0823	-1.68	1.68
85	5.4846	5.1965	4.9191	-1.70	1.70
86	5.3160	5.0336	4.7618	-1.73	1.73
87	5.1534	4.8765	4.6103	-1.76	1.76
88	4.9965	4.7251	4.4643	-1.79	1.79
89	4.8451	4.5790	4.3236	-1.82	1.81

Temp. (°C)	Max. Resistance value (kΩ)	Normal Resistance value (kΩ)	Min. Resistance value (kΩ)	Temp. Tol. (°C)	
90	4.6990	4.4381	4.1880	-1.85	1.84
91	4.5579	4.3022	4.0572	-1.88	1.87
92	4.4218	4.1711	3.9312	-1.91	1.90
93	4.2903	4.0446	3.8096	-1.94	1.92
94	4.1633	3.9225	3.6923	-1.97	1.95
95	4.0407	3.8046	3.5791	-2.00	1.98
96	3.9222	3.6908	3.4700	-2.03	2.01
97	3.8077	3.5810	3.3647	-2.06	2.04
98	3.6971	3.4748	3.2630	-2.09	2.07
99	3.5902	3.3724	3.1649	-2.13	2.10
100	3.4869	3.2734	3.0701	-2.16	2.12
101	3.3870	3.1777	2.9786	-2.19	2.15
102	3.2905	3.0853	2.8903	-2.22	2.18
103	3.1971	2.9960	2.8050	-2.25	2.21
104	3.1068	2.9096	2.7226	-2.28	2.24
105	3.0194	2.8262	2.6429	-2.32	2.27
R50=17.6KΩ ± 3%					
B0/100=3,970K ± 2%					

NOTE CONCERNING PROTECTION OF ENVIRONMENT

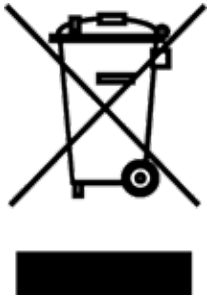

This product must not be disposed of via normal household waste after its service life, but must be taken to a collection station for the recycling of electrical and electronic devices. The symbol on the product, the operating instructions or the packaging indicate such disposal procedures. The materials are recyclable in accordance with their respective symbols. By means of re-use, material recycling or any other form of recycling old appliances you are making an important contribution to the protection of our environment. Please ask your local council where your nearest disposal station is located.

INFORMATION CONCERNING USED REFRIGERANT MEDIUM

The maintenance and the liquidation must be carried out by qualified personnel.

Type of refrigerant: R290

The quantity of the refrigerant: Please see the unit label.

The value GWP: 3

GWP = Global Warming Potential



Appliance filled with flammable gas R290

In case of quality problem or other please contact your local supplier or authorized service center.

Emergency number: 112

PRODUCER

SINCLAIR CORPORATION Ltd.
16 Great Queen Street
WC2B 5AH London
United Kingdom
www.sinclair-world.com

This product was manufactured in China (Made in China).

REPRESENTATIVE

SINCLAIR Global Group s.r.o.
Purkynova 45
612 00 Brno
Czech Republic

TECHNICAL SUPPORT

SINCLAIR Global Group s.r.o.
Purkynova 45
612 00 Brno
Czech Republic
Tel.: +420 800 100 285 | Fax: +420 541 590 124
www.sinclair-solutions.com | info@sinclair-solutions.com

