

„ORIGINAL INSTRUCTIONS“

IMPORTANT NOTE:

Read this manual carefully before installing or operating your new heat pump.
Make sure to save this manual for future reference.

CONTENTS

Part 1 General Information.....	3
Part 2 Engineering Data	7
Part 3 Component Layout and Refrigerant Circuits.....	15
Part 4 Control	20
Part 5 Diagnosis and Troubleshooting.....	26

Part 1

General Information

1 Lineup	4
2 Nomenclature	5

1 Lineup

Outdoor unit

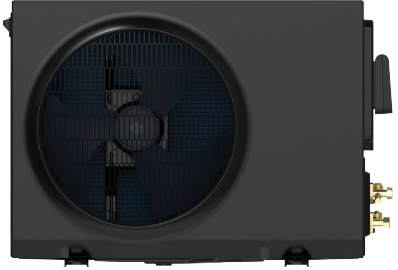
Model	Refrigerant	Capacity(kW)	Power supply(V/N/Hz)	Appearance
SWH-E20C	R454C	1.8	220-240/1/50	

Indoor unit

Model	Tank	Electric heater		Appearance
	Volume(L)	Capacity(kW)	Power supply(V/N/Hz)	
SWH-I200	200	2.1	220-240/1/50	
SWH-I300	300	2.1	220-240/1/50	

2 Nomenclature

Outdoor unit

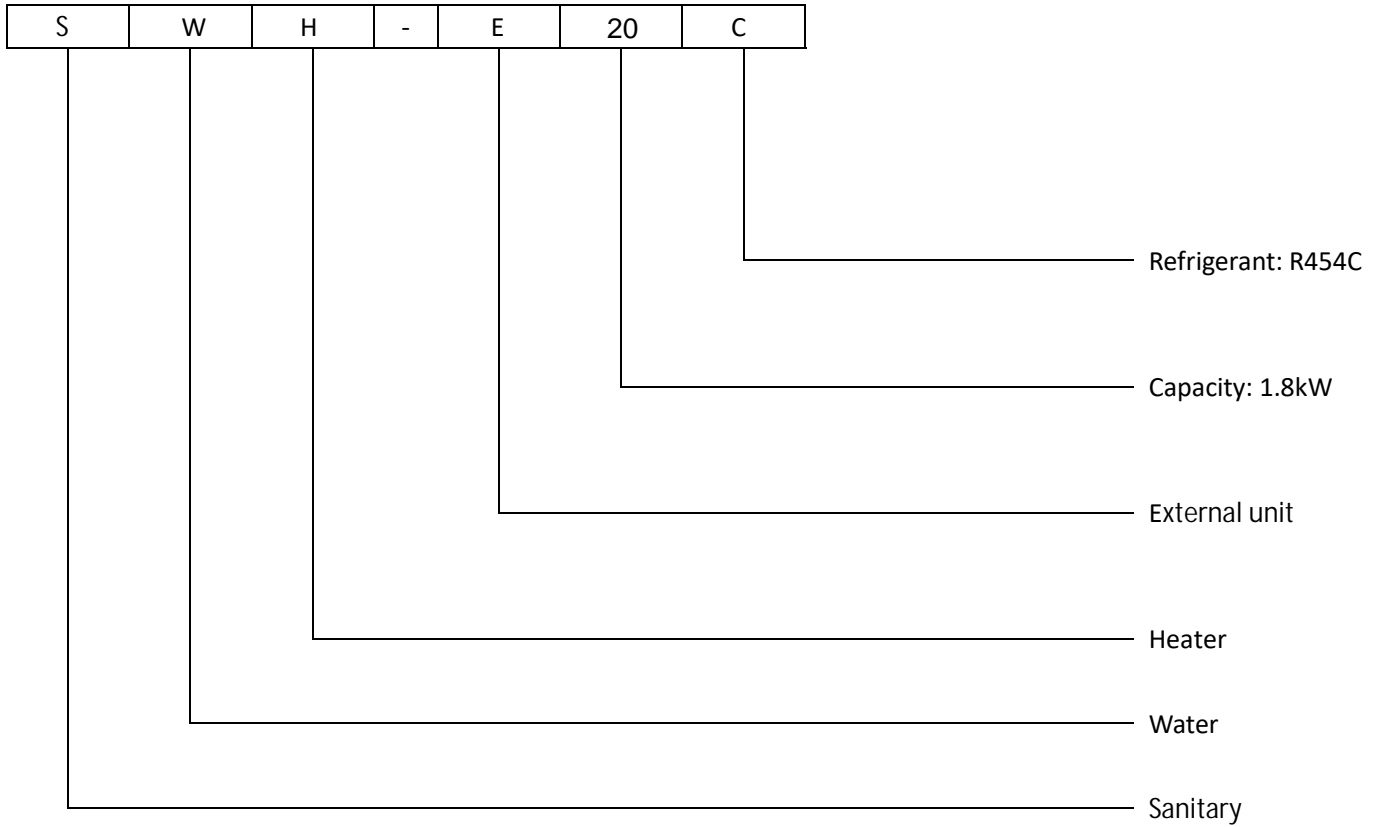

Water tank

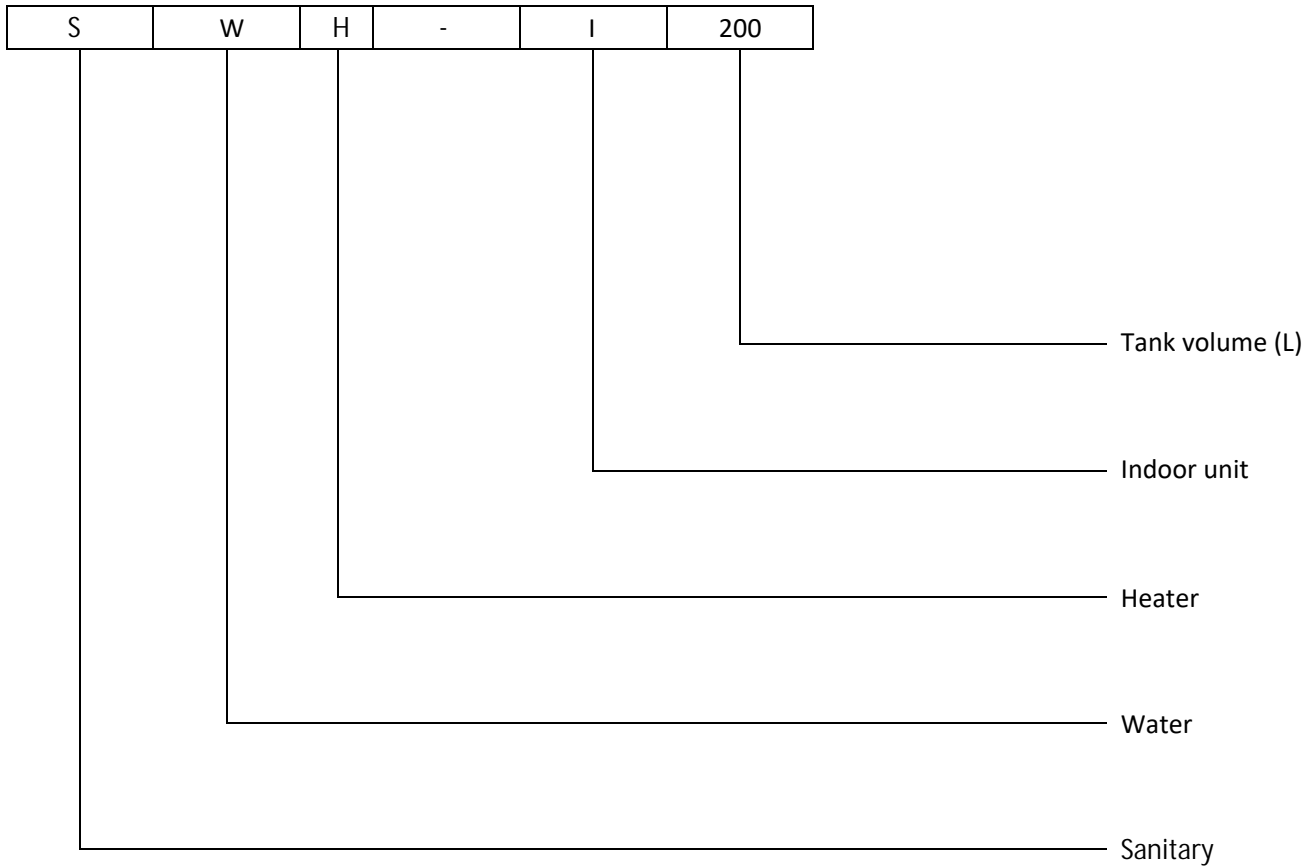

Part 2

Engineering Data

1 Specifications	8
2 Electrical Characteristics	9
3 Operating Limits.....	10
4 Heat Up Time	11
5 Dimensions and Center of Gravity	12

1 Specifications

Outdoor unit model		SWH-E20C		
Water Tank model		SWH-I200	SWH-I300	
Power supply	V/N/Hz	220-240/1/50		
Max current	A	4.6+9.1	4.6+9.1	
Max Input (HP+E-Heater)	W	1050+2100	1050+2100	
HP operating Ambient temperature	°C	-15~46	-15-46	
Leaving water temperature	°C	38-70 (Default 54)		
Design pressure	Mpa	3.3		
Heating capacity ¹	W	1800	1800	
Hot water yield	m ³ /h	0.0443	0.0443	
En16147 ²	Load profiles	/	L	XL
	Water Heating energy efficiency	/	124.4%	144.6%
	COP	/	2.98	3.49
	Energy efficiency class	/	A+	A+
	V40	L	256	365
	θWH	°C	53.5	53.9
	AEC	kWh	823	1159
NF	Category	/	★★★	
Piping	liquid side	mm/inch	Φ6.35/Φ1/4'	
	Gas side	mm/inch	Φ9.52/Φ3/8'	
	Max. height difference	m	20	
	Max. refrigerant pipe length ³	m	30	
Refrigerant	Type/charge	g	R454C/900g	
Compressor type	/	DC inverter compressor		
Fan	/	DC		
Air side heat exchanger	/	Hydraulic aluminum fin + Inner grooved copper tube		
Throttle type		Electric expansion valve		
Outdoor sound pressure level	dB(A)	60		
Outdoor unit	Unit dimension (L*W*H)	mm	804*327*555	
	Packing dimension (L*W*H)	mm	845*390*630	
	Net weight	kg	27	
	Gross weight	kg	30	
Water Tank	Tank Volume	L	190	280
	Unit dimension (L*W*H)	mm	505*505*1661	580*580*1730
	Packing dimension (L*W*H)	mm	600*595*1770	690*675*1835
	Net weight	kg	77.5	99
	Gross weight	kg	85.5	110

Notes:

1. Test condition: 7/6°C, start water temperature is 10°C, termination temperature 45°C.
2. Test condition: Average climate (7/6°C), set temperature 54°C.
3. Need additional refrigerant charging if pipe length is more than 10m.

2 Electrical Characteristics

System	Outdoor unit				Power current		Compressor		Fan	
	Voltage (V)	Hz	Min. (V)	Max. (V)	MCA (A)	MOP (A)	MSC (A)	RLA (A)	kW	FLA (A)
SWH-E20C	230	50	198	264	2	15	1	4.6	0.05	0.2

Note:

MCA: Min. Circuit Amps. (A)

MOP: Maximum Over Protector Amps (A)

MSC: Max. Starting Amps. (A)

RLA: Rated Load Amps. (A)

The input Amps of compressor where MAX. Hz can operate for nominal cooling or heating test condition

kW: Rated Motor Output

FLA: Full Load Amps. (A)

3 Operating Limits

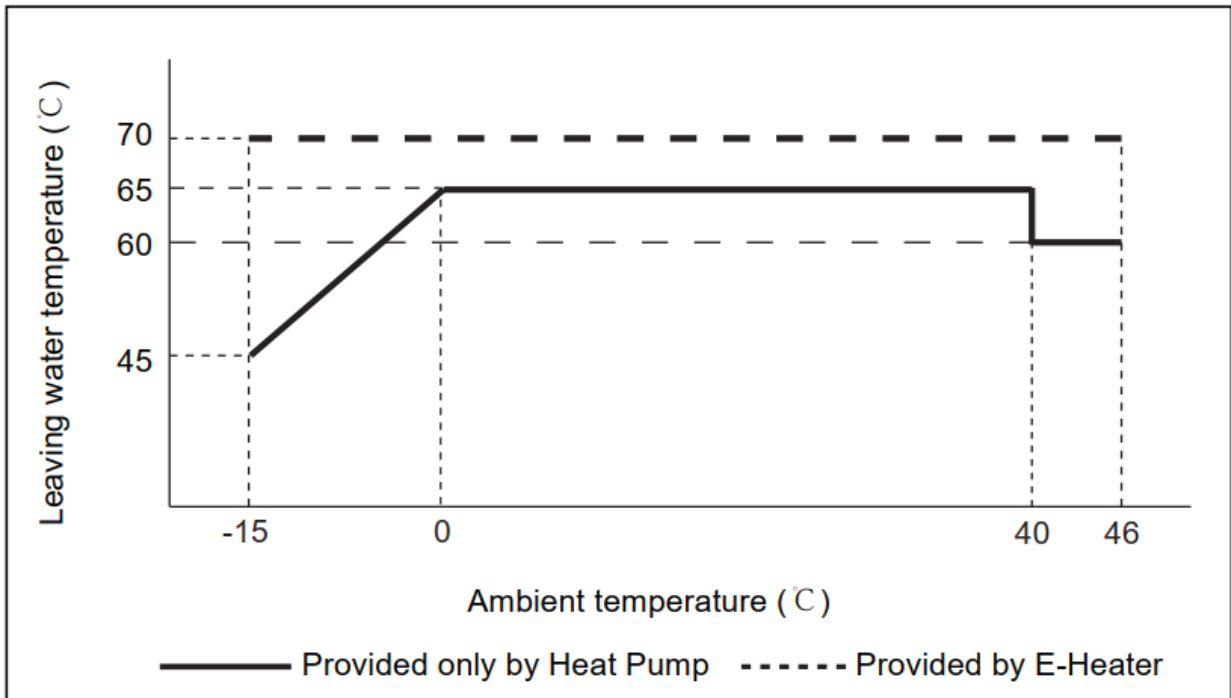

4 Heat Up Time

200L

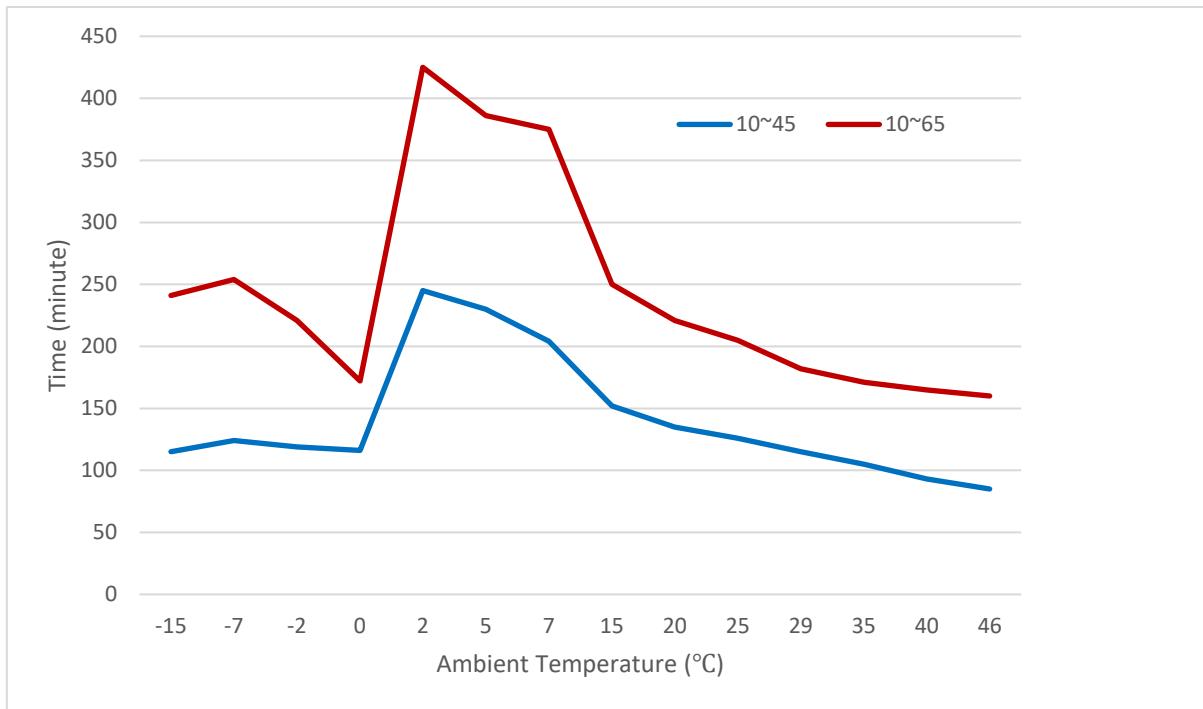

300L

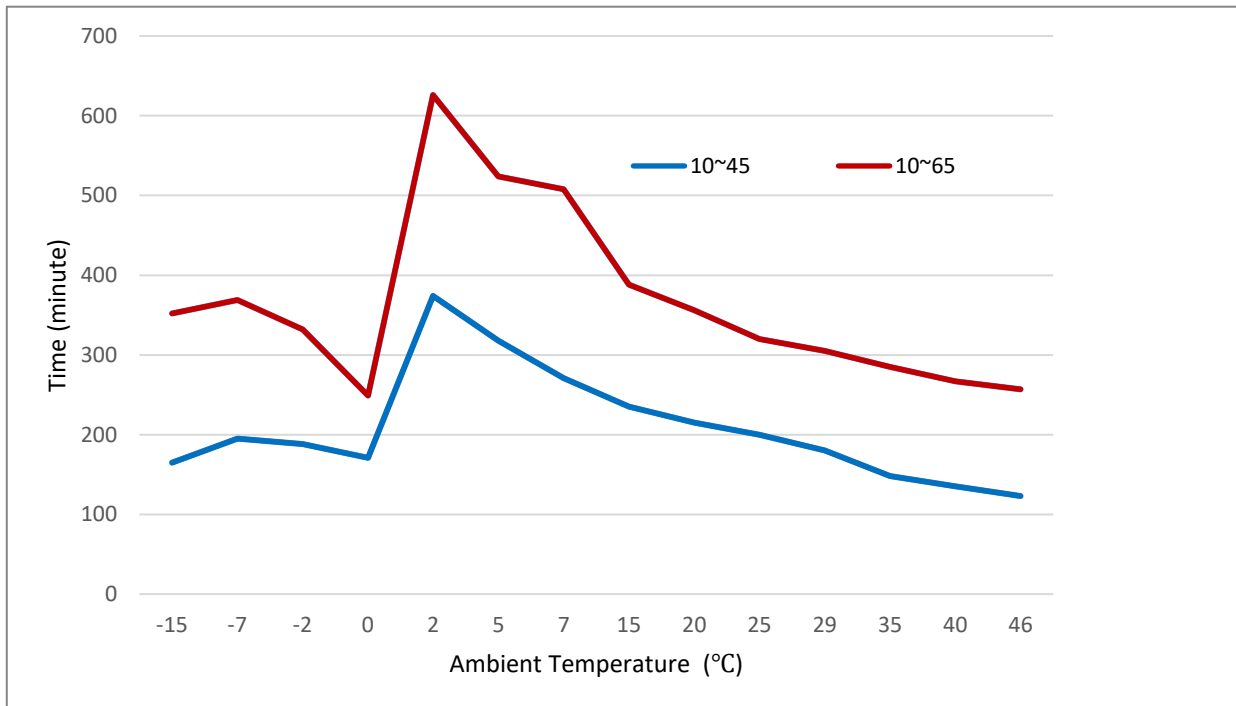

Note:

1. The frequency of the compressor under -15°C is higher than that under -7°C , so the heating time is slightly less than that under -7°C .
2. The maximum temperature of heat pump heating varies in different environmental temperatures. When the maximum temperature of heat pump heating is below 65°C , the electric heating will continue to heat up to 65°C after the heat pump stops.
3. When the ambient temperature is below 2°C , the E-heater and heat pump operate simultaneously to shorten the heating time.

5 Dimensions and Center of Gravity

Unit: mm

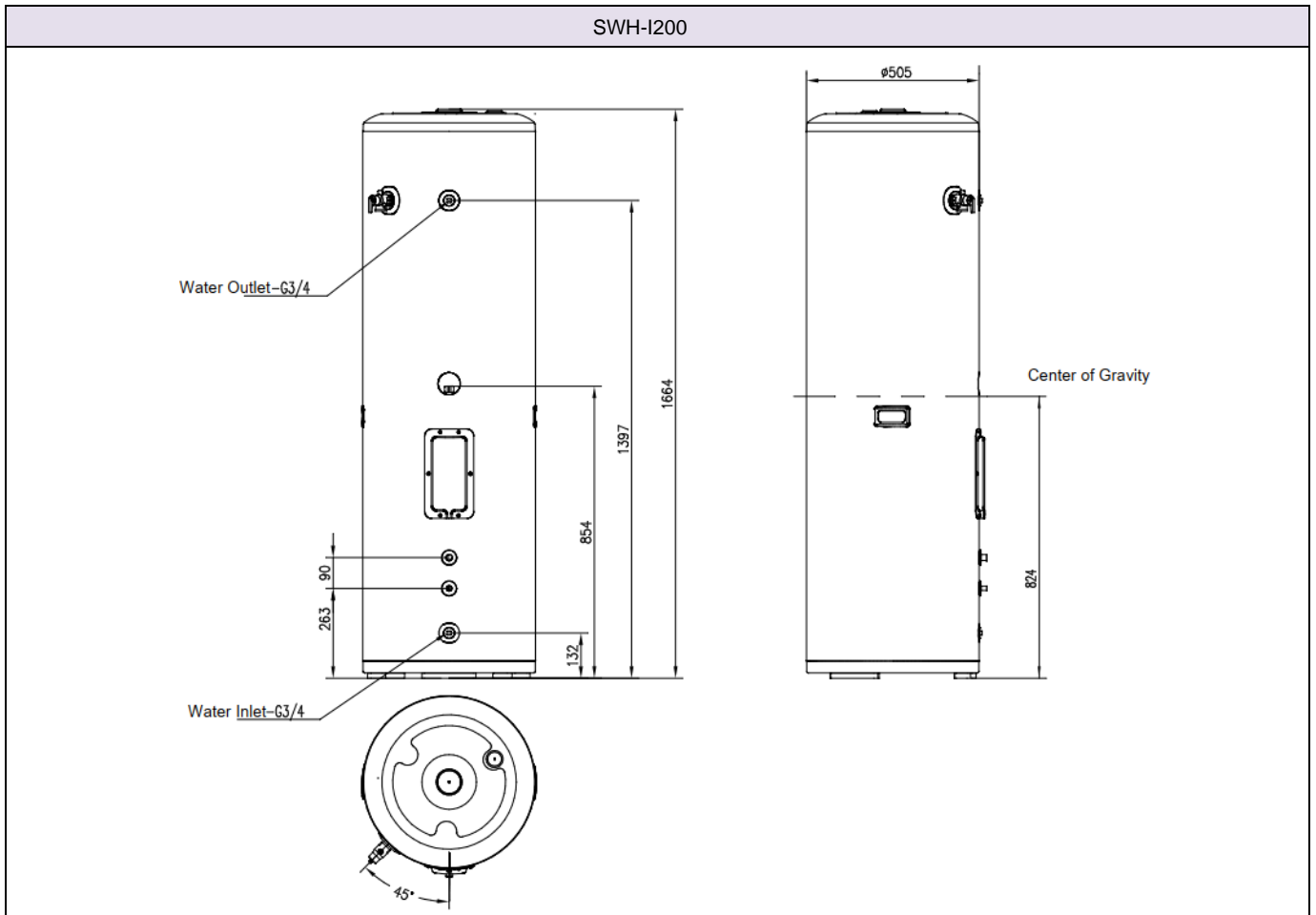
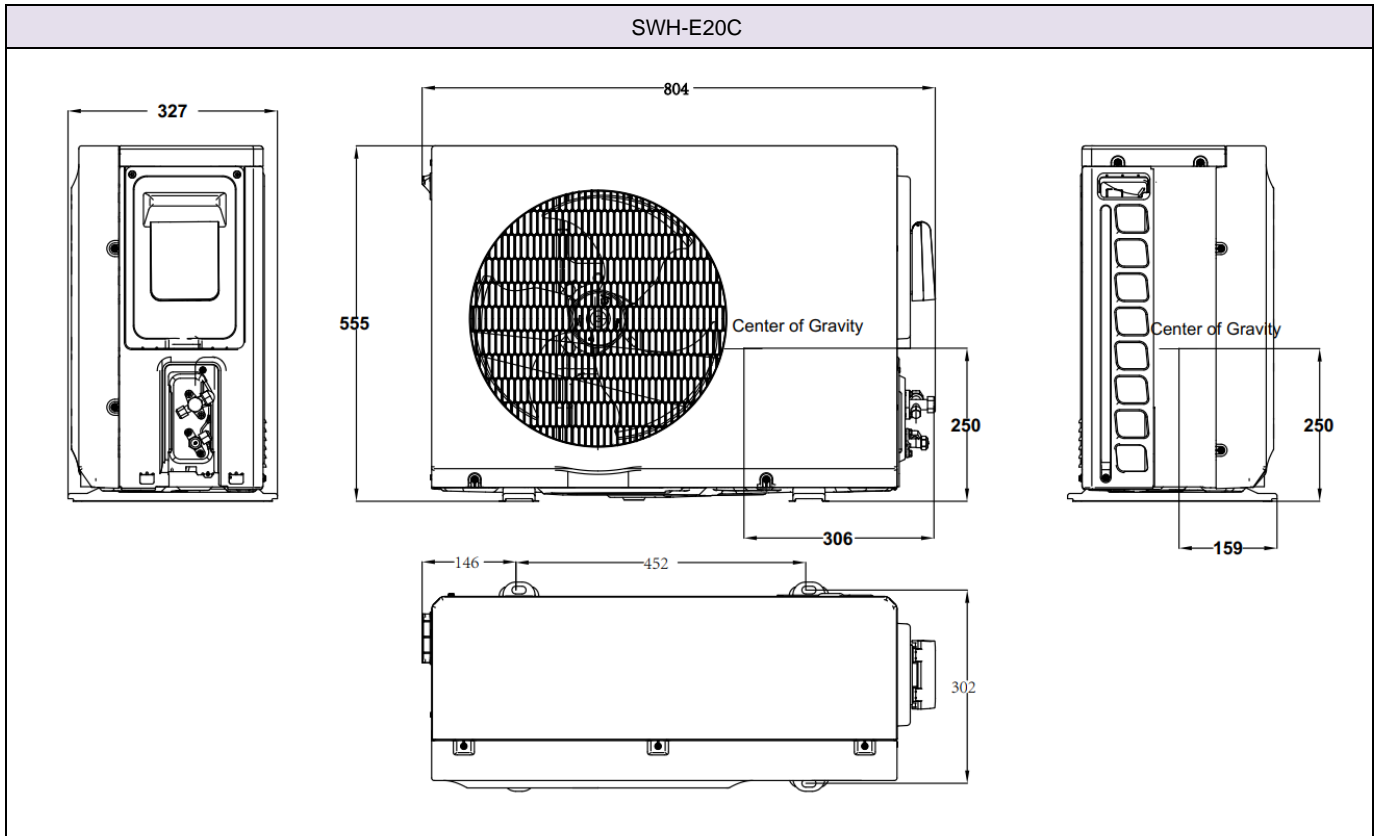

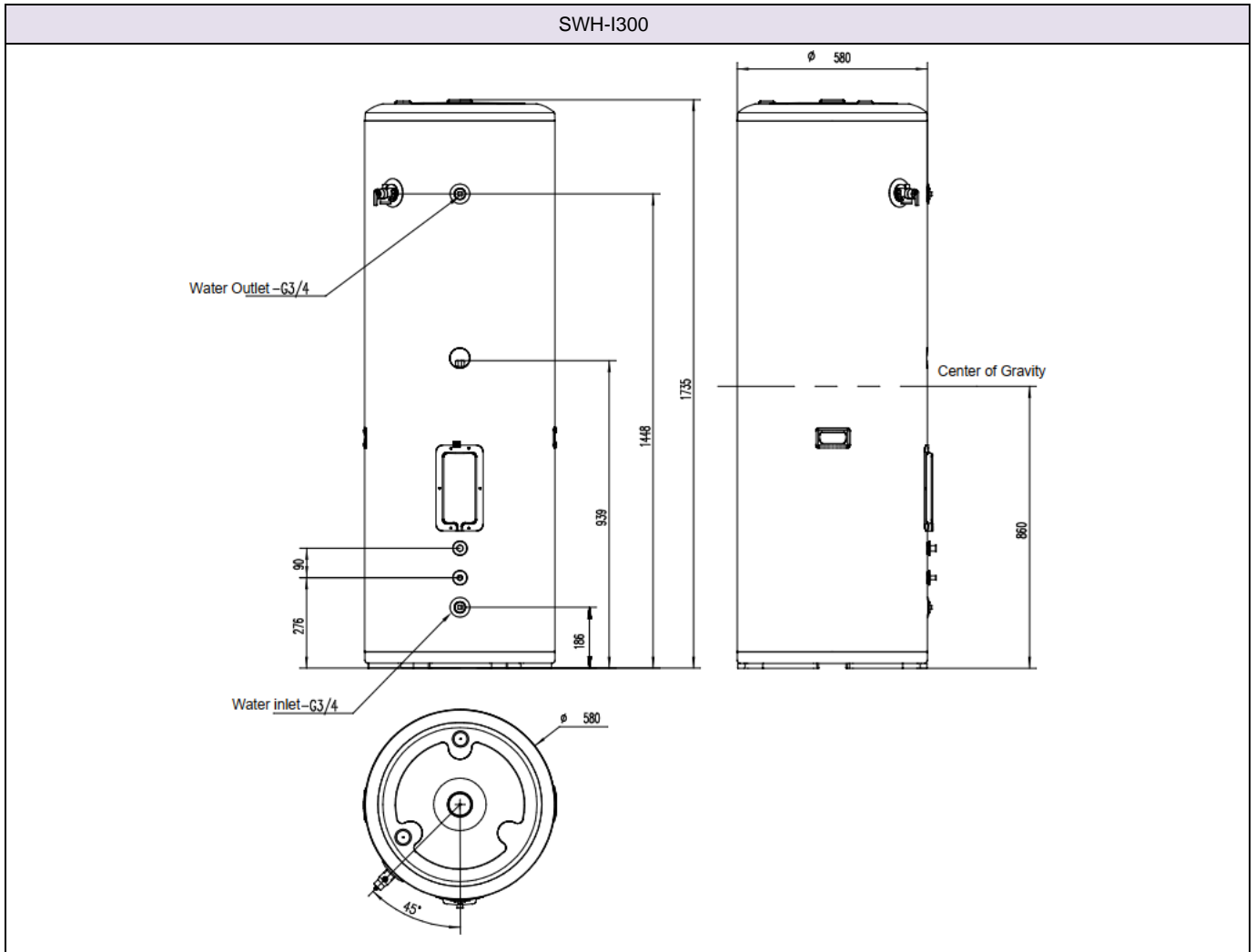

Part 3

Component Layout and Refrigerant Circuits

1 Layout of Functional Components.....	16
2 Piping Diagrams	18

1 Layout of Functional Components

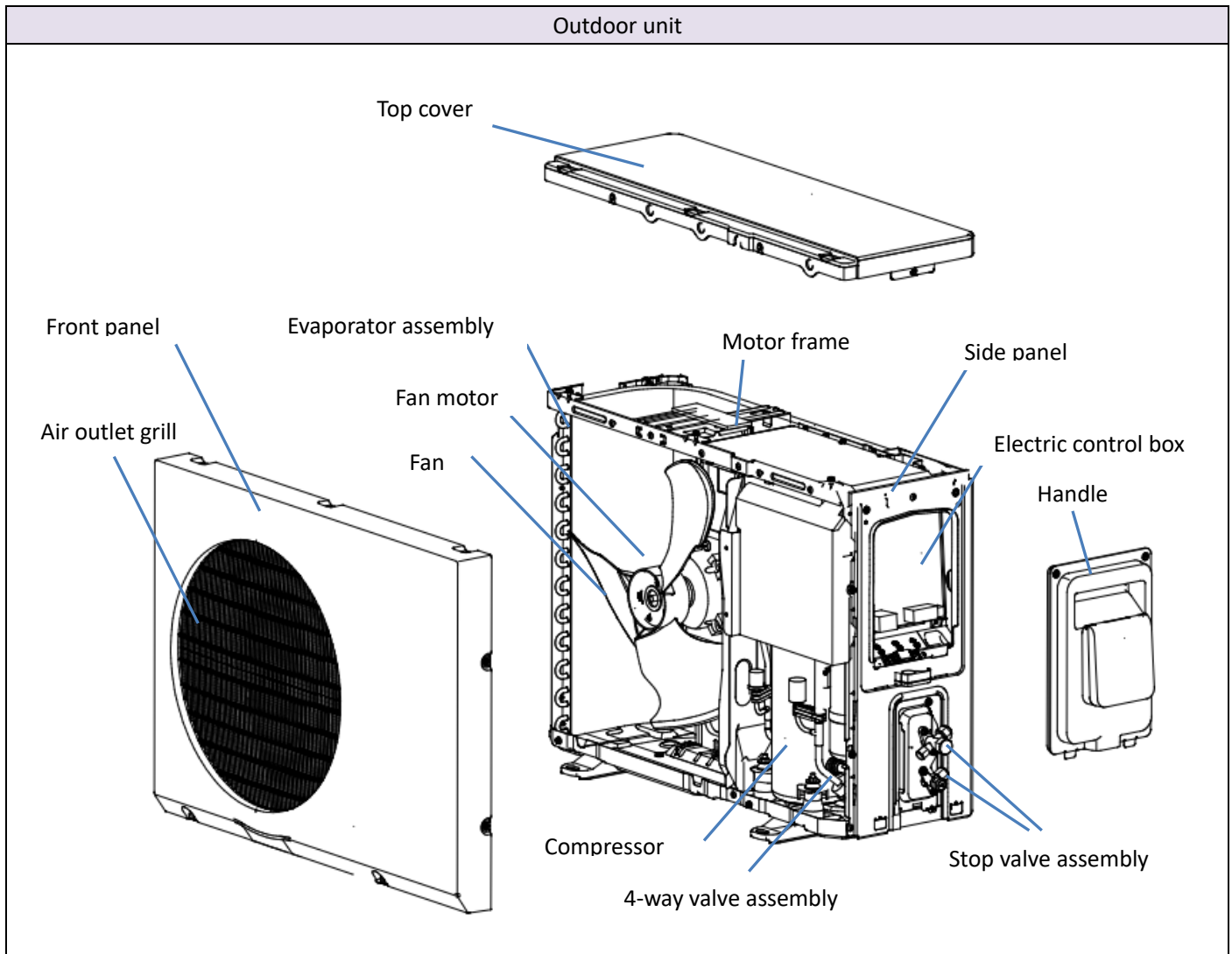

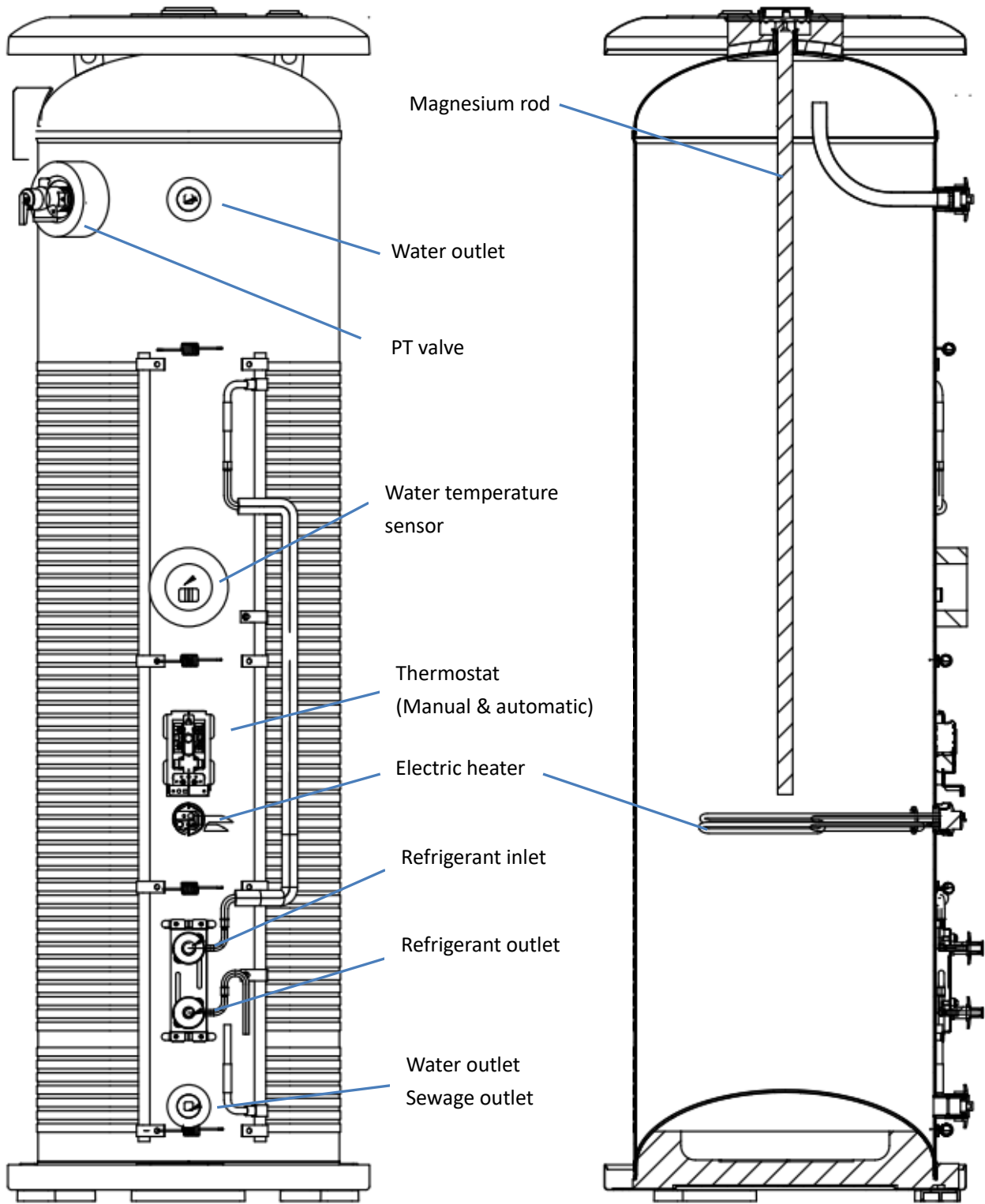
Water Tank

2 Piping Diagrams

Refrigerant piping graphic example:

- High temperature, high pressure gas
- High temperature, high pressure liquid
- Low temperature, low pressure gas liquid mixture
- Low temperature, low pressure gas

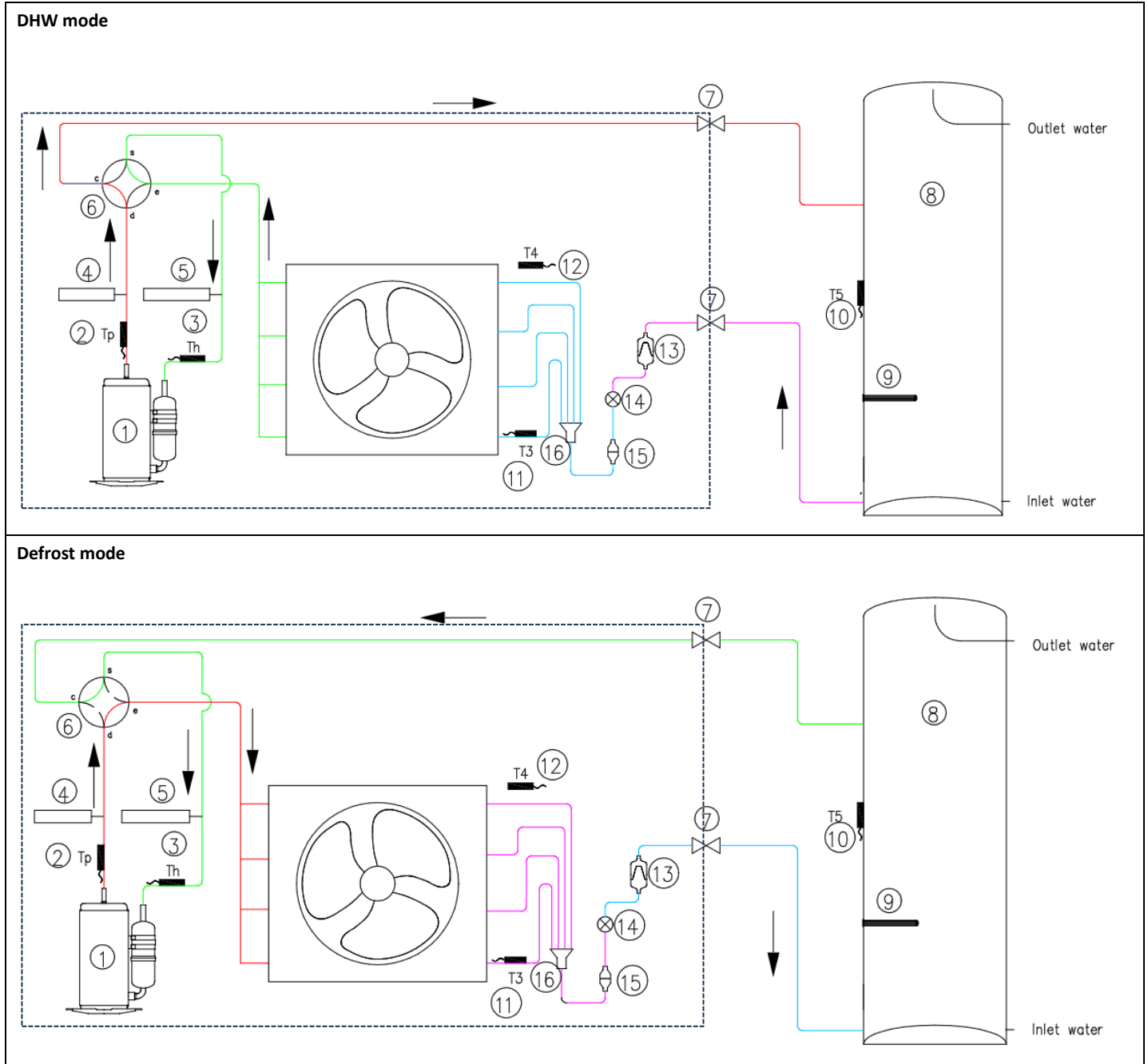

Legend

1	Compressor	9	Electric heater
2	Discharge temperature sensor (Tp)	10	Water tank temperature sensor(T5)
3	Suction temperature sensor (Th)	11	Air side heat exchanger refrigerant inlet temperature sensor(T3)
4	High pressure switch	12	Ambient temperature sensor(T4)
5	Low pressure switch	13	Stainer
6	4-way valve	14	Electronic expansion valve
7	Stop valve	15	Strainer
8	Water tank	16	Distributor

Key components:**Compressor**

When the refrigerant gas passes through the compressor, refrigerant pressure increases and temperature rises above that of the water in tank.

For initial power on, compressor starts after a delay of at least three minutes. If compressor runs for less than 6min, then the start interval would be adjusted to 6min.

Electronic expansion valve (EXV):

Controls refrigerant flow and reduces refrigerant pressure. When power on, EXV moves to the standby position. After the compressor starts, the EXV is controlled according to suction superheat and discharge temperature.

Four-way valve:

The four-way valve is used to change the direction of refrigerant flow in order to switch between defrost/refrigerant recycle and DHW operations. During the defrost mode and refrigerant recycle mode, 4-way valve is powered on, the air side heat exchanger functions as a condenser and coil inside the tank functions as an evaporator. For other situations, 4-way valve is powered off, the air side heat exchanger functions as an evaporator and coil inside the tank functions as a condenser.

High pressure switch:

Regulate refrigerant system pressure. When refrigerant system pressure rises above the upper limit, the high pressure switch turns off, stopping the compressor. When the high pressure protection recovers, the compressor restarts.

Low pressure switch:

Regulate system pressure. When system pressure drops below the lower limit, the low pressure switch turn off, stopping the compressor. When the low pressure protection recovers, the compressor restarts.

Fan assembly:

Forcing air convection to enhance the heat exchange performance.

High and low fan speed control, according to condenser temperature (T3) and discharge temperature (Tp)

Control for heat pump operating only:

Fan motor stops after a delay of 30s after compressor stops. During defrost mode, fan motor always stops.

Control for electric heater operating only:

When ambient temperature (T4) $\geq 43^{\circ}\text{C}$, fan motor starts with low speed for electric box heat dissipation.

Electric heater:

After power on for 10s, electric heater runs the self-test procedure. It turns on for 5s and then turns off. During the process, IEH (Electric heater current) is detected.

Part 4

Control

1 Automatically ON/OFF and electric heater control.....	21
2 SG ready	22
3 Hybrid.....	22
4 OPT. Backup.....	23
5 Disinfection.....	24

1 Automatically ON/OFF and electric heater control

1.1 Automatically control

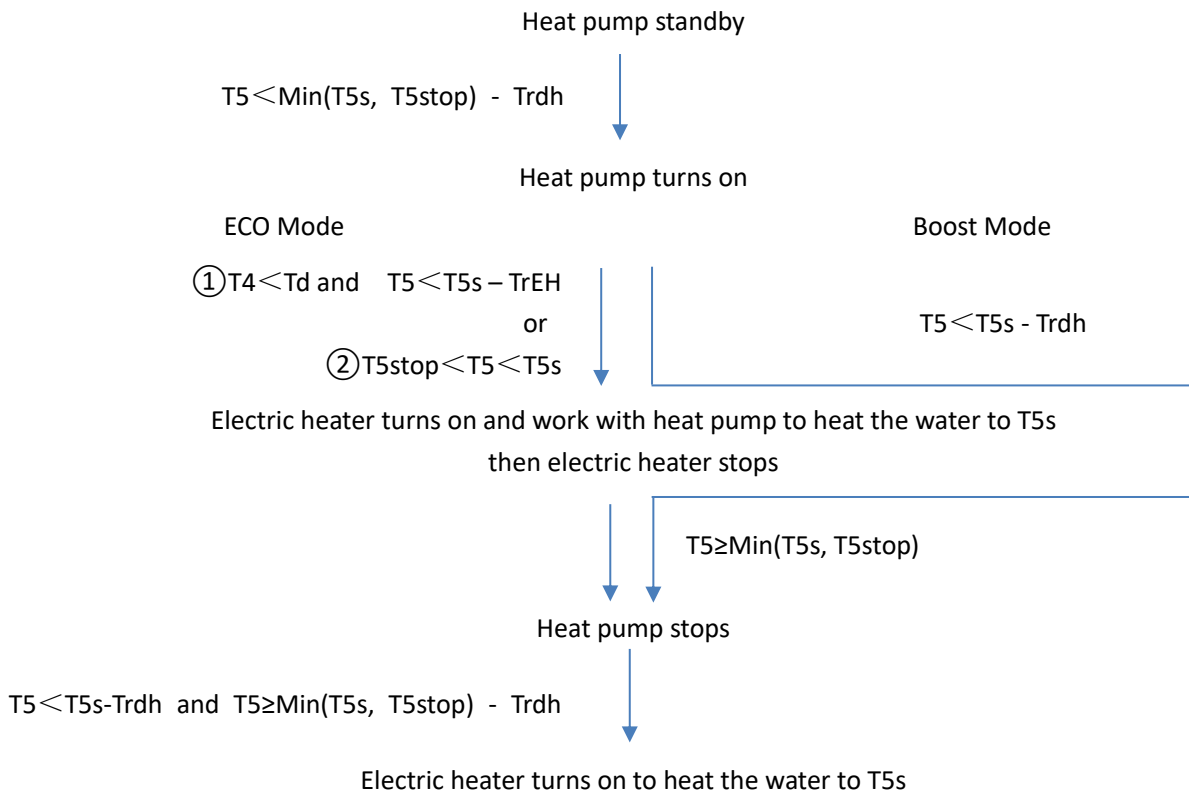

Note:

1. T5s: Water setting temperature
2. T5: Water tank temperature
3. Trdh: Restart offset temperature, temperature difference between Water setting temperature(T5s) and Water tank temperature(T5) above which heat pump turns on (default 5 °C)
4. T5stop: Maximum water temperature that heat pump stops for general operation, which relates to ambient temperature T4 (Refresh every 15min)

T4	(-∞, -16]	(-16, -12]	(-12, -9]	(-9, -5]	(-5, -2]	(-2, 0]	(0, 40]	(40, 46]	(46, +∞)
T5stop	HP stops	45	47	52	55	60	65	60	HP stops

5. Td: Electric heater working ambient temperature, below which electric heater can work with heat pump (default 0°C)
6. TrEH: Electric auxiliary heating startup hysteresis (default 10 °C)

1.2 Manually electric heater control

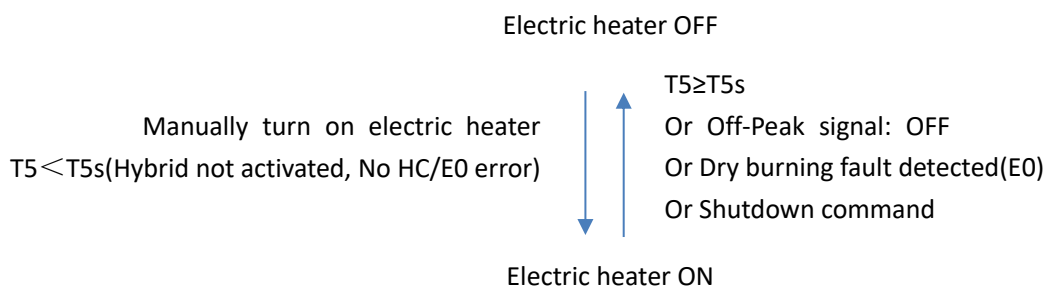

Note:

1. T5: Water tank temperature
2. T5s: Water setting temperature
3. HC: No current fault of E-Heater

2 SG ready (SG 3.0)

In Smart Grid function, SG1 port and SG2 port jointly detect power grid signals. The combination rules are as follows (0 indicates that the port is disconnected, 1 indicates that the port is closed).

SG1 port	SG2 port	Point check code for the wire controller	Unit operation
1	1	3	Adjust the set water temperature to 3°C higher than the original set water temperature
0	1	2	Change set point to 70°C, set Trdh minimum and Td maximum;
1	0	1	Normal operation
0	0	0	Normal operation

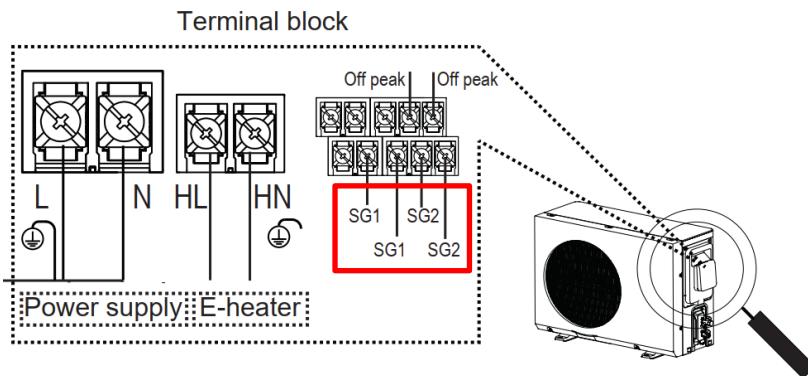

SG1 & SG2 signal receiving port

3 Hybrid

When heat pump is under the low efficiency operation range, wired controller will remind user to turn on additional heating source in order to satisfy the heating demand.

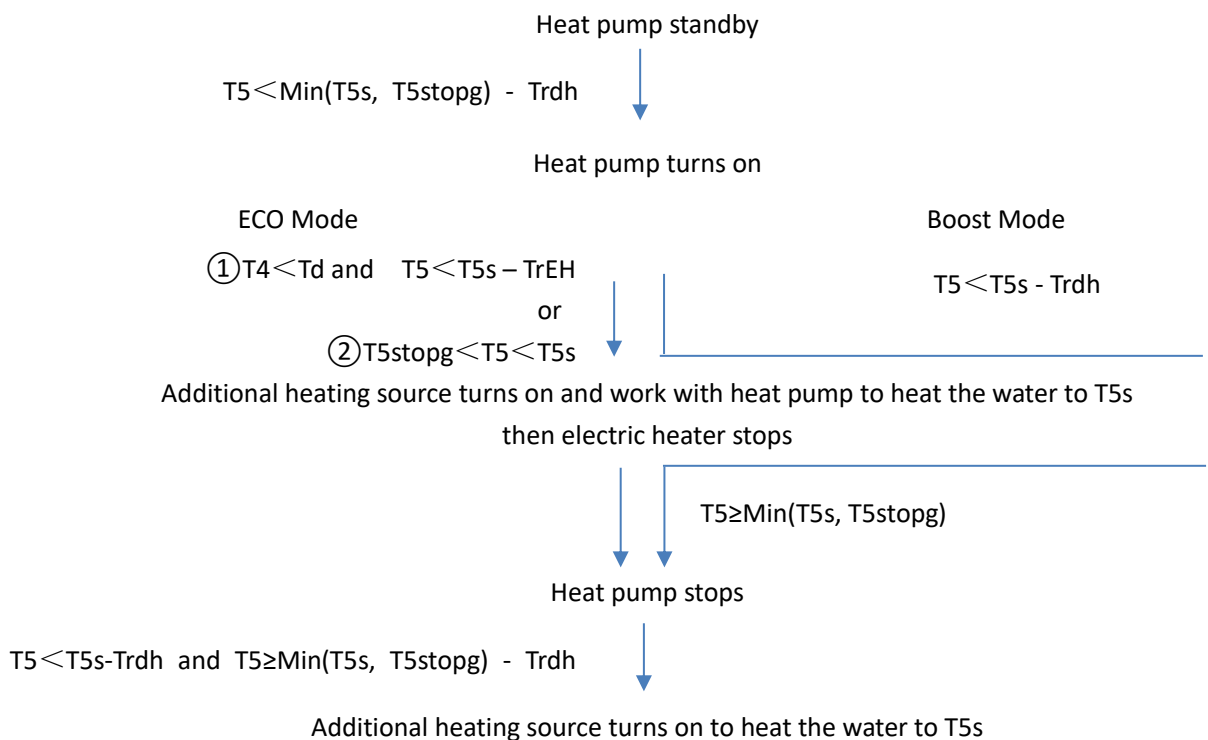

Note:

1. Electric heater is not available under hybrid mode, even heat pump has error.
2. T5s: Water setting temperature

3. T5: Water tank temperature
4. Trdh: Restart offset temperature, temperature difference between Water setting temperature(T5s) and Water tank temperature(T5) above which heat pump turns on
5. T5stopg: Maximum water temperature that heat pump stops for Hybrid mode, which relates to ambient temperature T4 (Refresh every 15min)

T4	$(-\infty, -14)$	$[-14, -10)$	$[-10, -7)$	$[-7, -2)$	$[-2, 2)$	$[2, 5)$	$[5, 7)$	$[7, 10)$
T5stopg	Heat pump stops	30	34	38	42	46	50	54
T4	$[10, 15)$	$[15, 20)$	$[20, 25)$	$[25, 32)$	$[32, 37)$	$[37, 46)$	$[46, \infty)$	
T5stopg	58	60	65	62	60	60	Heat pump stops	

6. Hybrid function and OPT. Backup function cannot take effect at the same time
7. Additional heating source uses E-Heater port when the Hybrid function is on.
8. OPT. Backup function and Hybrid function cannot take effect at the same time.

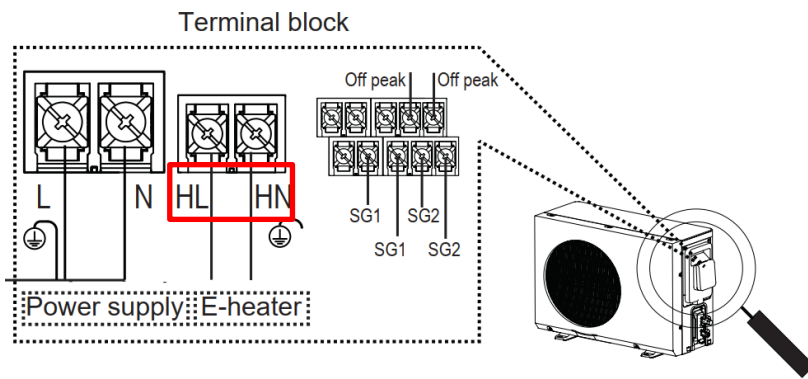

Additional heating source controlling port

4 OPT. Backup

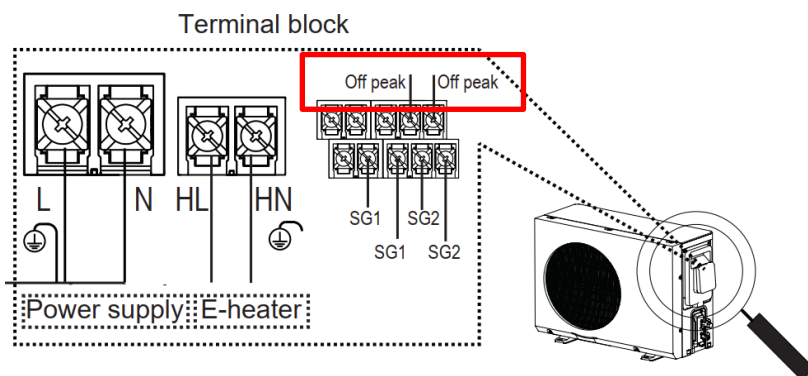

Off-Peak (Off-Peak signal receiving port)

OPT. Backup function is an application of valley electricity utilize. It detects Off-peak signal which means electric price is at low price. When Off-peak signal is ON, water will be heated by heat pump preferentially.

If the off peak signal is off, indicating normal control of the unit and automatic operation based on user settings.

If the off peak signal is on and the current setting mode is ECO mode, the electric auxiliary heating system will be controlled to start and stop according to T5:

- 1) If $T5 < T5s$ Trdh, turn on electric heating.
- 2) Stop electric heating after $T5 \geq T5s$.

If the current setting mode is Boost mode, the set temperature will increase by 5 degrees (up to 70 °C). After there is no signal from off peak, it will return to the original set temperature and be controlled normally;

Note:

OPT. Backup function and Hybrid function cannot take effect at the same time

5 Disinfection

Disinfection ON (Received disinfection command)

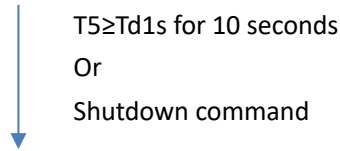

Disinfection Off

Note:

1. If compressor and electric heater fail, disinfection mode does not exit. Disinfection process will continue until compressor fault is fixed.
2. T5: Water tank temperature
4. Td1s: Disinfection temperature
5. The disinfection cycle, time, and disinfection temperature are set by the user. When the sterilization function is turned off, the unit does not perform periodic sterilization (disinfection function is default ON)
6. The unit also has a manual disinfection function. When manual disinfection is turned on, the unit immediately carries out disinfection.

Part 5

Diagnosis and Troubleshooting

1 Electric Wiring Diagram	27
2 Electric Control Box Layout.....	28
3 PCB	29
4 Spot Check List	31
5 Normal Operating Parameters Range	31
6 Error Code Table.....	32
7 Troubleshooting	33
8 Temperature Sensor Resistance Characteristics	53

1 Electric Wiring Diagram

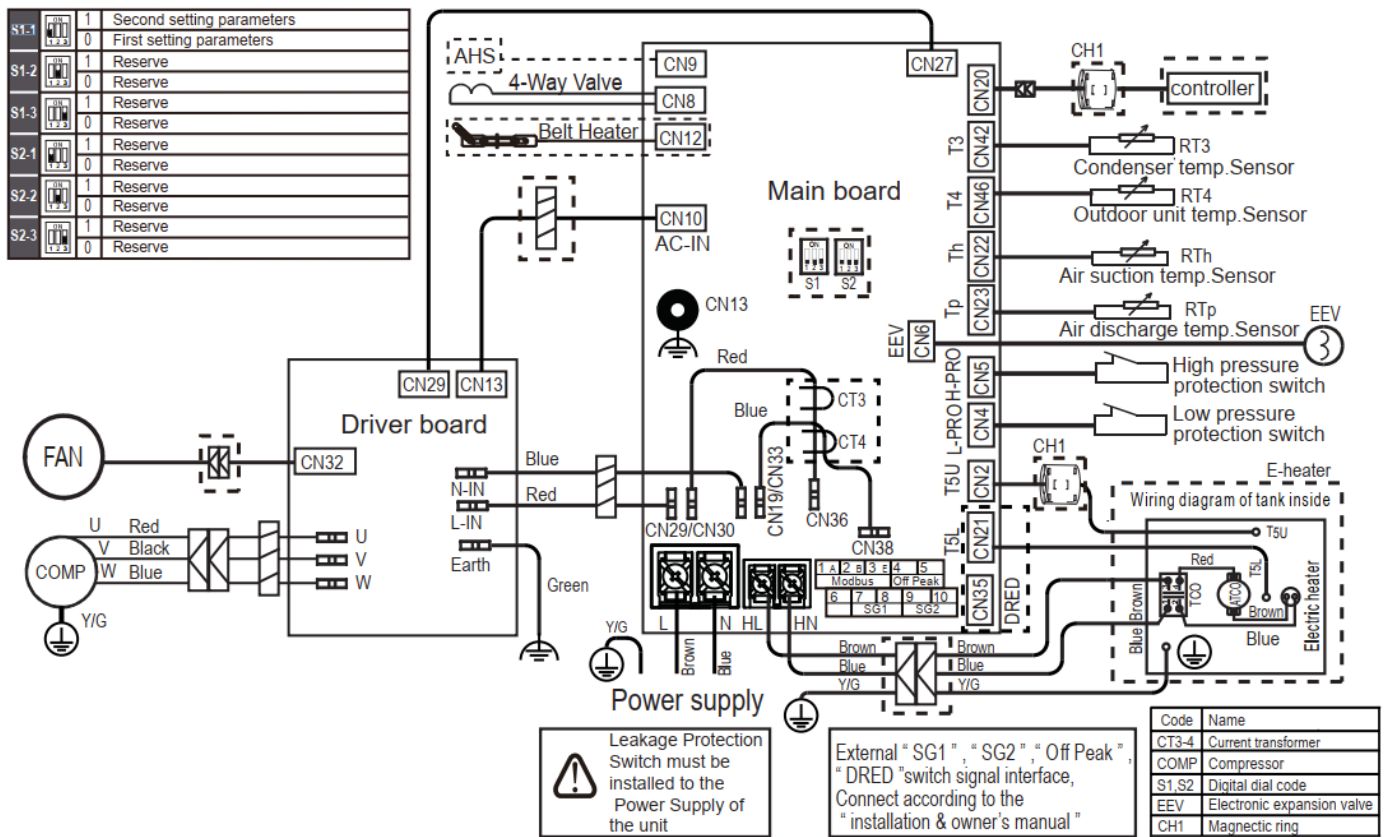

DIP switch settings

Switch		OFF=0	ON=1
S1-1		First setting parameters	Second setting parameters
S1-2		Reserved	Reserved
S1-3		Reserved	Reserved

2 Electric Control Box Layout



Main PCB

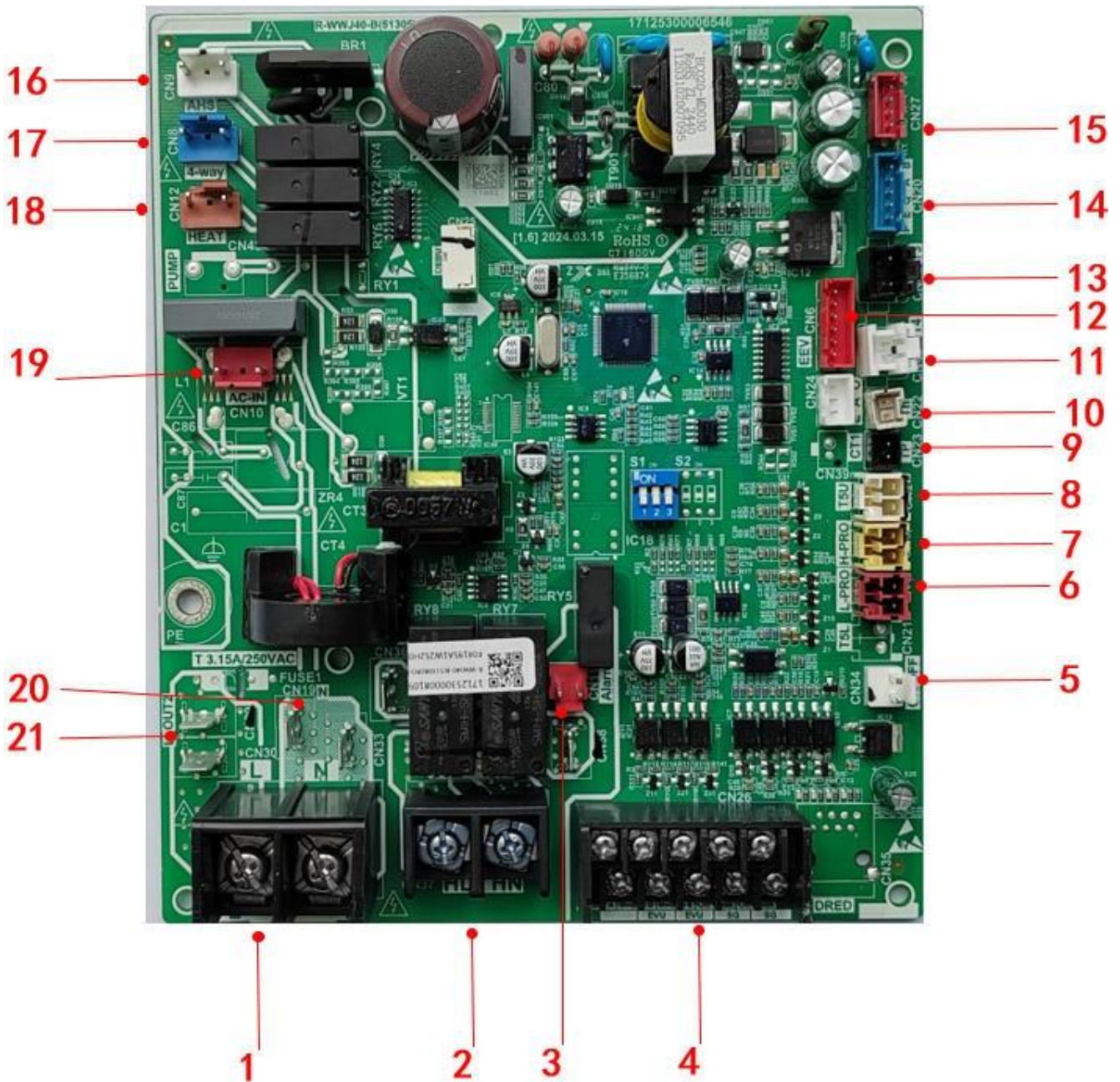

Inverter Module Board box

3 PCB
3.1 Main PCB Board

Label	Port	Code	Content	Voltage(V)
1	CN1	POWER	Port for power supply	198-254VAC
2	CN37	E-HEATER POWER	Port for E-heater power supply	198-254VAC
3	CN11	Alarm (Reserve)	Port for Alarm passive signal output	0V
4	CN26	Modbus, SG1, SG2, Off Peak	Port for Modbus, SG1, SG2, Off Peak	Modbus:0-5V, SG1/SG2/Off Peak:0-12V
5	CN34	ON/OFF(Reserve)	Port for remote ON/OFF	0-12V
6	CN4	L-PRO	low pressure switch	0-5V
7	CN5	H-PRO	high pressure switch	0-5V
8	CN2	T5	Water tank temperature sensor	0-5V
9	CN23	TP	Discharge temperature sensor	0-5V

10	CN22	Th	Suction temperature sensor	0-5V
11	CN46	T4	ODU ambient temperature sensor	0-5V
12	CN6	EEV	Electronic expansion valve	0-12V
13	CN42	T3	Heat exchanger temp. of outdoor unit	0-5V
14	CN20	PQEAB	Port for controller	0-12V
15	CN27	GND R T 5V	Communication between main control board and module board	0-5V
16	CN9	AHS(Reserve)	Port for External heat source signal	198-253VAC
17	CN8	4-way	Port for 4-way	198-253VAC
18	CN43	HEAT	Port for Chassis electric heating belt	198-253VAC
19	CN10	AC-IN	Port for Power of main control board	198-253VAC
20	CN19/CN33	N	Branch terminal	198-253VAC
21	CN29/CN30	L-OUT2	Branch terminal	198-253VAC

3.2 Inverter Module Board

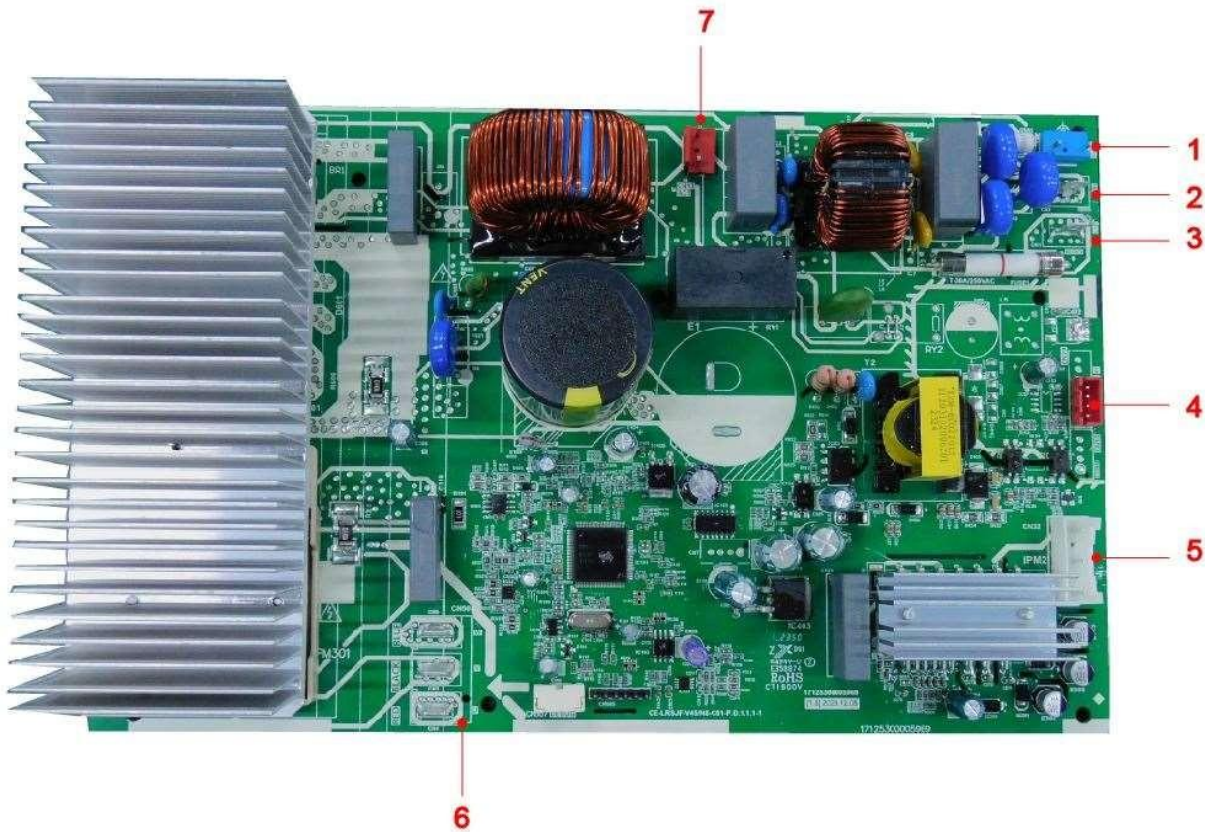

Label	Port	Code	Content	Voltage(V)
1	CN14	Earth	Port for functional earthing	0V
2	CN2	N-IN	Port for N	
3	CN1	L-IN	Port for L	198-253V
4	CN29	GND R T 5V	Communication between main control board and module board	0-5V
5	CN32	FAN	Port for FAN	
6	CN4&CN5&CN6	U\ V\ W	Port for compressor	56-310V
7	CN13	AC1	Port for power of main control board	198-253VAC

4 Spot Check List

No	Parameter	Explanations	Unit
1	Fan speed	Current fan speed	RPM
2	EXV1	EXV opening	P
3	Fr	Operating frequency of the compressor	Hz
4	Current	Total current input	A
5	Voltage	AC voltage input	V
6	Power	Total power input	W
7	Tp	Discharge temperature, Tp	°C
8	Th	Suction temperature, Th	°C
9	T3	External heat exchanger temperature, T3	°C
10	T4	External ambient temperature, T4	°C
11	T5	Tank temperature, T5	°C
12	Td	Activation temperature of E-Heater	°C
13	Trdh	Restart offset temp. of unit	°C
14	TrEH	Restart offset temp. of E-Heater	°C
15	SGSL	Smart Grid signal	/
16	AP	Cumulative estimated power consumption	kWh
17	RT-HP	Real-Time Heating Power	W
18	RT-PW	Real-Time Heating Capacity	W
19	Sum-HP	Cumulative Heating Capacity	kWh
20	COP	The energy efficiency of the unit	/
21	Time1	Cumulative operating time of unit	h
22	Time2	Cumulative operating time of compressor	h
23	Time3	Cumulative operating time of E-Heater	h
24	Oil Return	Oil Return (0 is off,1 is on)	/

5 Normal Operating Parameters Range

T4 (Ambient temperature)	Tp (Discharge temperature)	Th (Suction temperature)
$T4 < -15^{\circ}\text{C}$	$T5+5 \leq T_p \leq T5+30$	$T4-5 \leq T_h \leq T4+3$
$-15^{\circ}\text{C} \leq T4 < 10^{\circ}\text{C}$	$T5+5 \leq T_p \leq T5+30$	$T4-7 \leq T_h \leq T4+3$
$10^{\circ}\text{C} \leq T4 < 25^{\circ}\text{C}$	$T5+10 \leq T_p \leq T5+30$	$T4-10 \leq T_h \leq T4$
$T4 \geq 25^{\circ}\text{C}$	$T5+15 \leq T_p \leq T5+40$	$T4-20 \leq T_h \leq T4$

6 Error Code Table

Error code	Content
bA	The ambient temperature exceeds the declared range (not an error)
d0	Oil return mark (not an error)
bb	Low heat pump capacity
E0	Water shortage/dry heating of water tank error
E2	Communication error
E3	Water tank temperature sensor error (T5)
E5	ODU heat exchanger temperature sensor error (T3)
E6	ODU ambient temperature sensor error (T4)
E9	Suction temperature sensor error (Th)
EA	Discharge temperature sensor error (Tp)
EE	EEPROM error
EF	Clock chip error
EP	electric leakage error (electric auxiliary heat)
P0	Low pressure protection
P1	High pressure protection
P3	Compressor overcurrent protection (frequency conversion)
P4	High discharge temperature (Tp) protection
PA	Low water temperature protection
C7	Heat sink high temperature protection
CH	The electrical auxiliary heat overcurrent error
H1	Communication malfunction between main control board and inventor board
H4	Three times L0 protects
H6	Dc fan error
H7	Voltage protection
HC	E-heater error (Current is less than 2A when e-heater operating)
HH	H6 protection occurs for six times within 60 minutes (Rolling judgment)
HP	Smart Grid signal error
F2	Low super-heat of discharge protection
F6	Electric expansion valve joint fault
L0	IPM module overcurrent or weak magnetic protection (corresponding to L0x class)
L1	Module or winding high temperature protection (corresponding to L1x class)
L2	Bus voltage protection or missing phase (corresponding to L2x class)
L3	EEPROM, Driver optocoupler malfunction (upper and lower bridge), current sampling, PFC sampling bias exception (corresponding to L3x)
L4	Out of step protection
L5	Zero speed protection
L7	Phase loss, short circuit to ground, motor winding, inductance and other abnormal protection
LA	Program check class exception
Lb	PFC protection

7 Troubleshooting

7.1 Warning

Warning



- All electrical work must be carried out by competent and suitably qualified, certified and accredited professionals and in accordance with all applicable legislation (all national, local and other laws, standards, codes, rules, regulations and other legislation that apply in a given situation).
- Power-off the outdoor units before connecting or disconnecting any connections or wiring, otherwise electric shock (which can cause physical injury or death) may occur or damage to components may occur.

7.2 How to judge whether the temperature sensor is normal

Measure sensor resistance.

If the resistance is not consistent with the sensor resistance characteristics table, the sensor has failed. Please refer to “8 Temperature Sensor Resistance Characteristics” for more details.

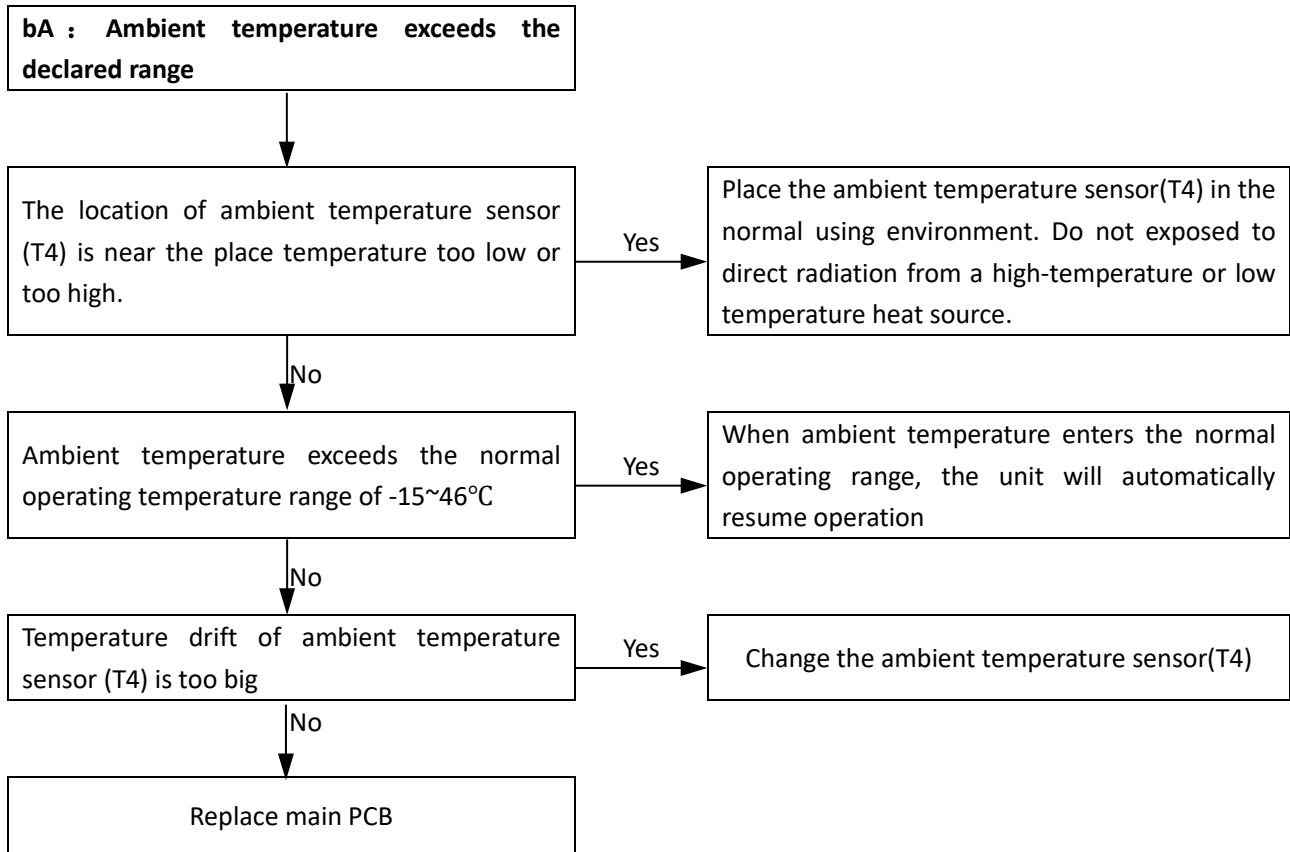
7.3 bA Troubleshooting

7.4 db Troubleshooting
7.4.1 Protection logic
db: Anti-freezing operation

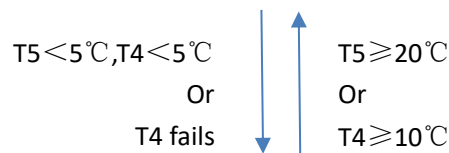
Unit Off or standby

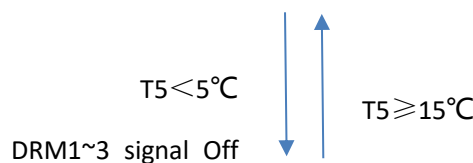

DHW operation



Heat pump stops, electric heater (if equipped) ON

Note:

1. T5: Water tank temperature sensor
2. T4: Ambient temperature sensor
3. DRM1~DRM3: Smart grid signal

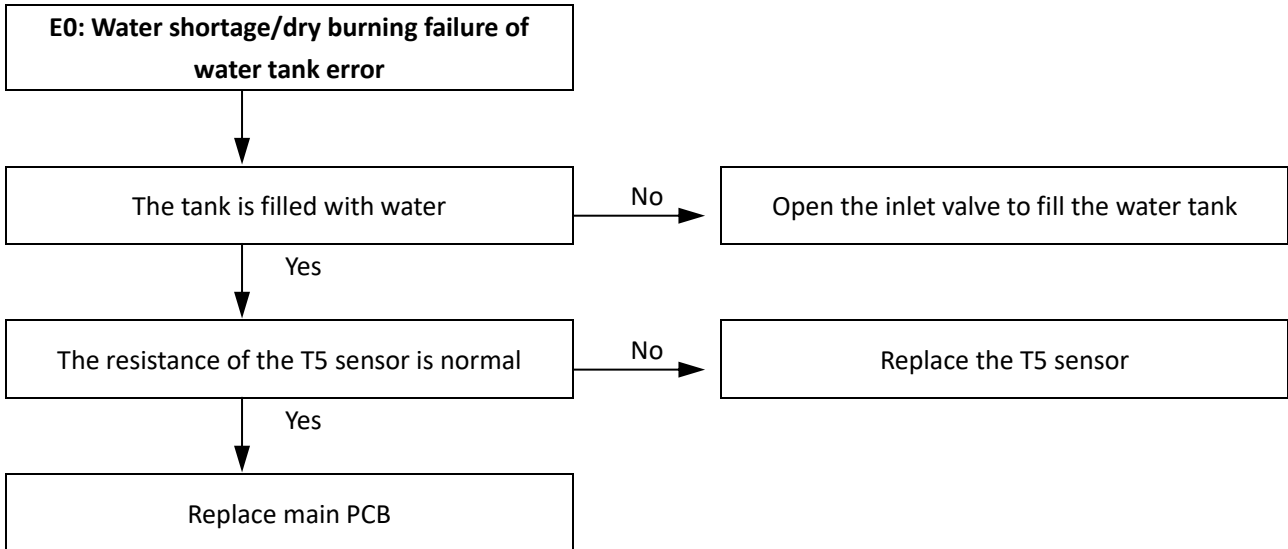
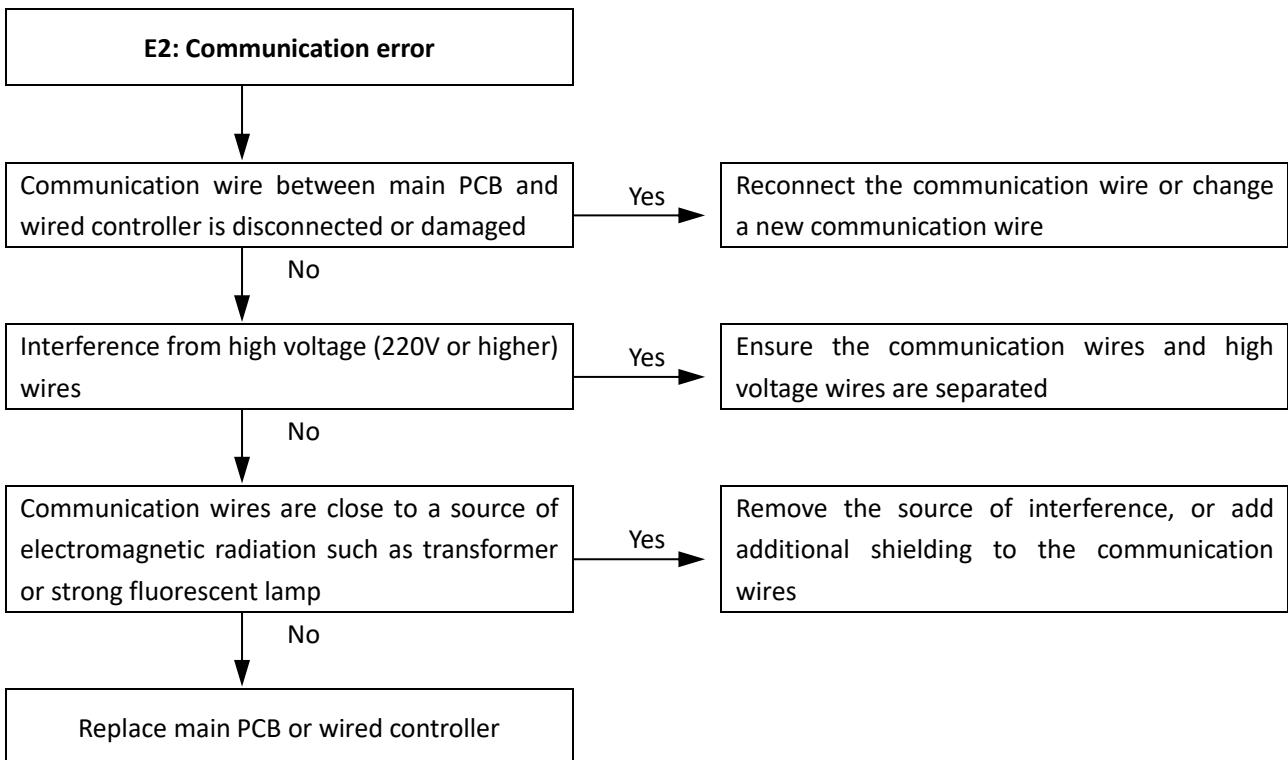
7.5 E0 Troubleshooting

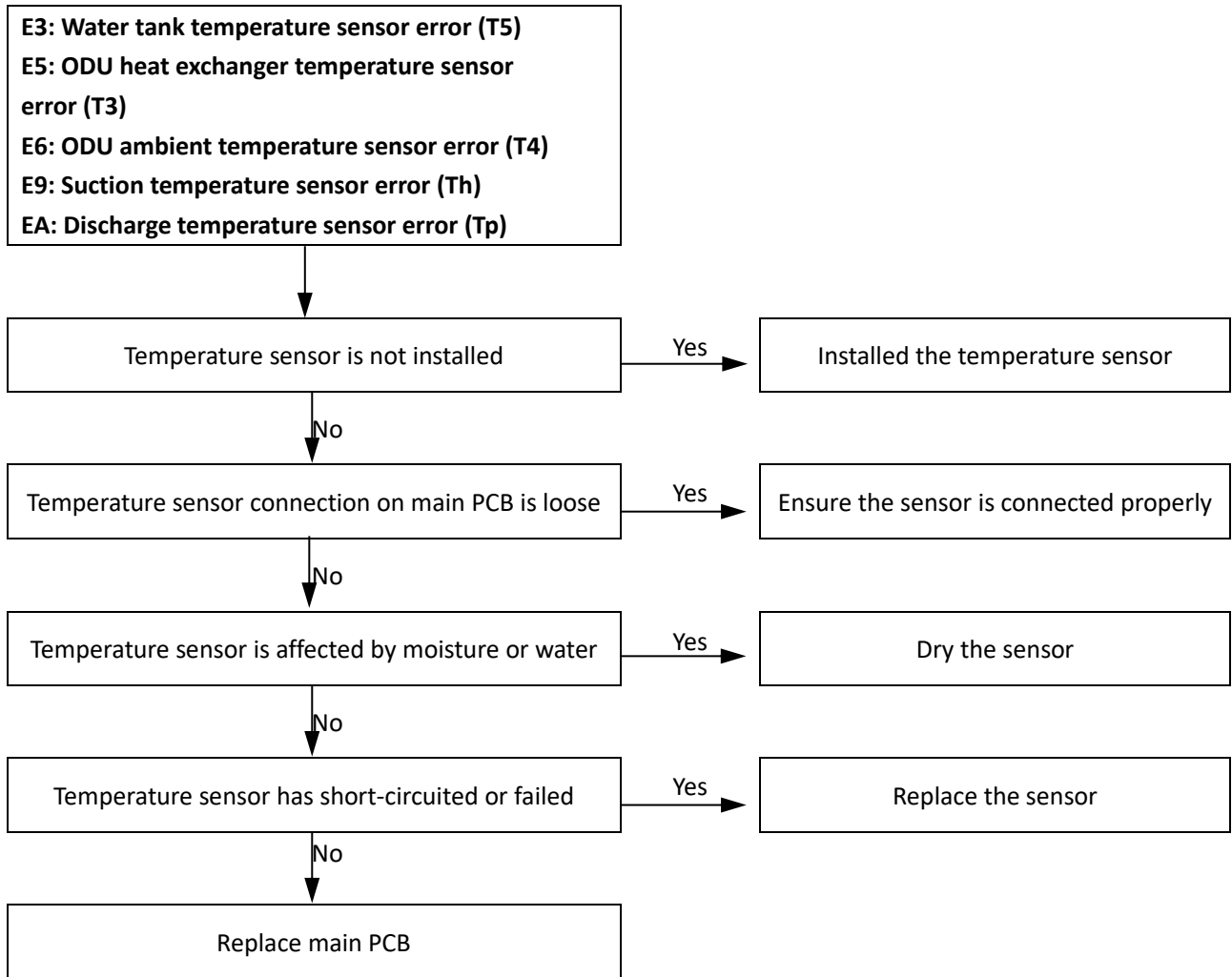
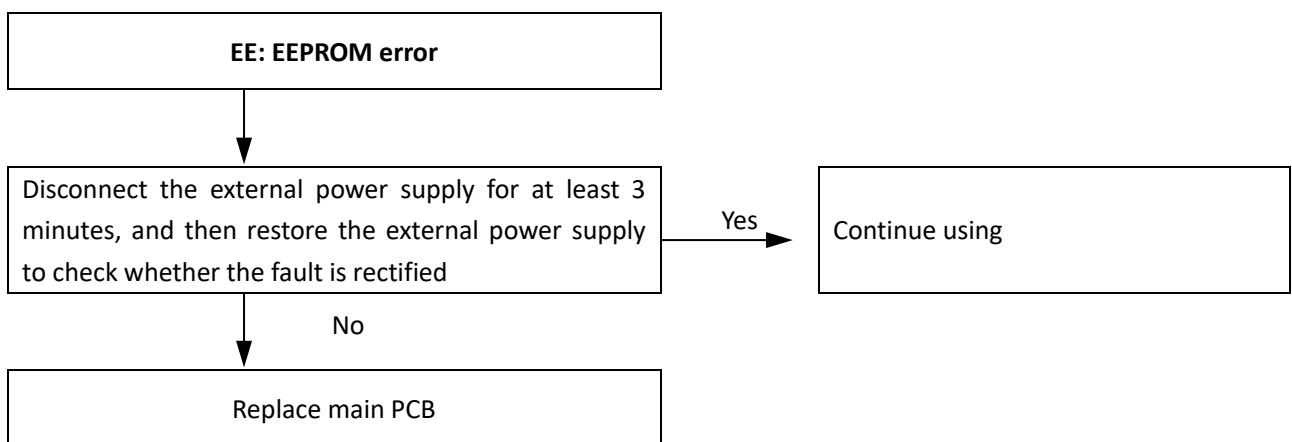
7.6 E2 Troubleshooting

7.7 E3, E5, E6, E9, EA Troubleshooting

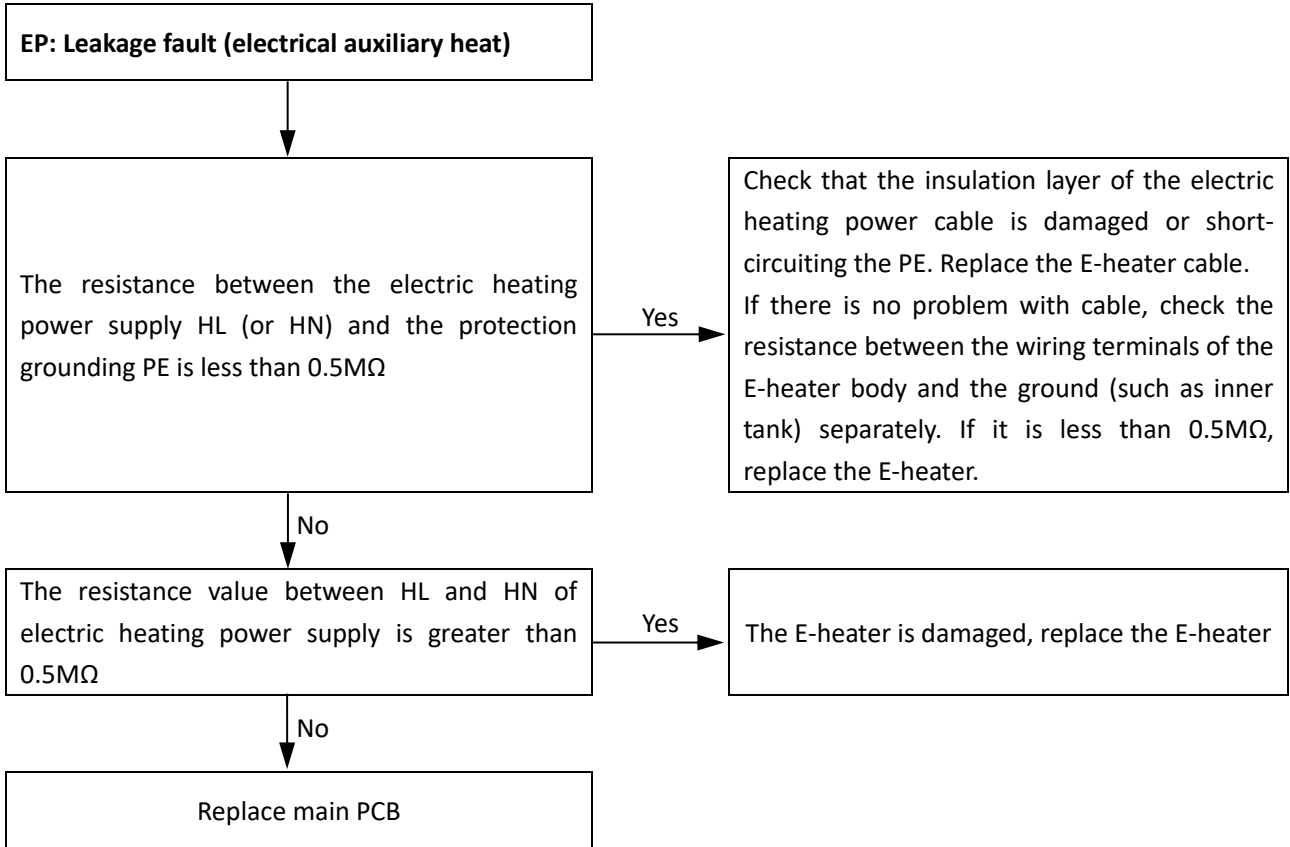
7.8 EE Troubleshooting

7.9 EP Troubleshooting

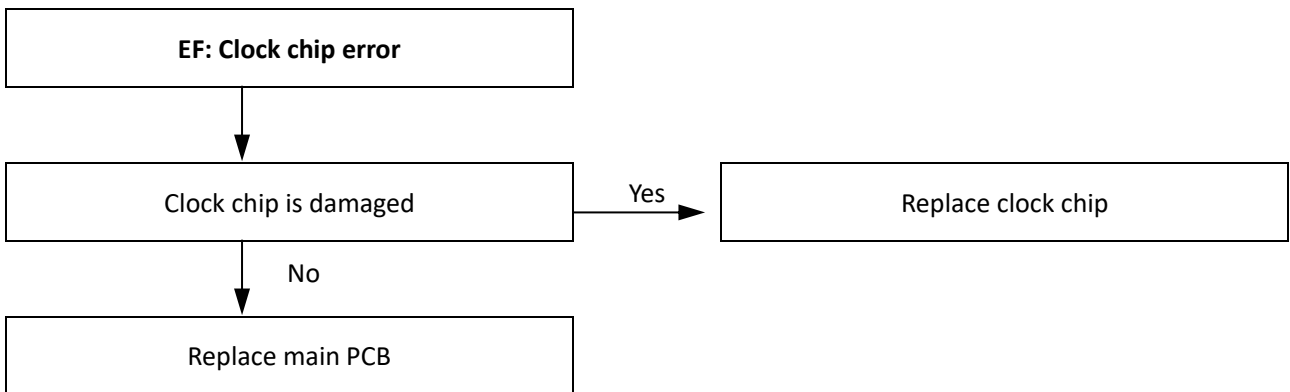

7.10 EF Troubleshooting

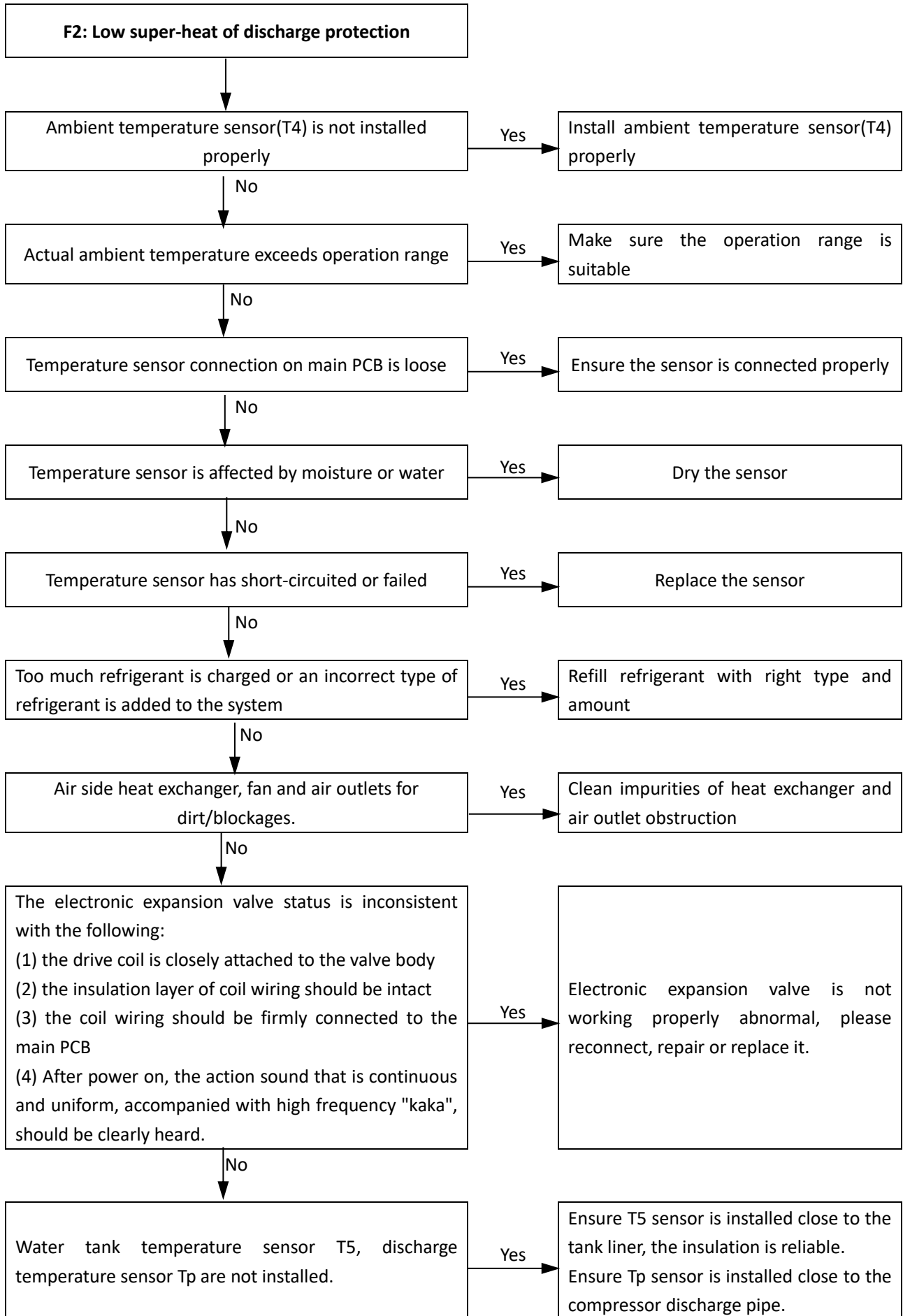

7.11 F2 Troubleshooting

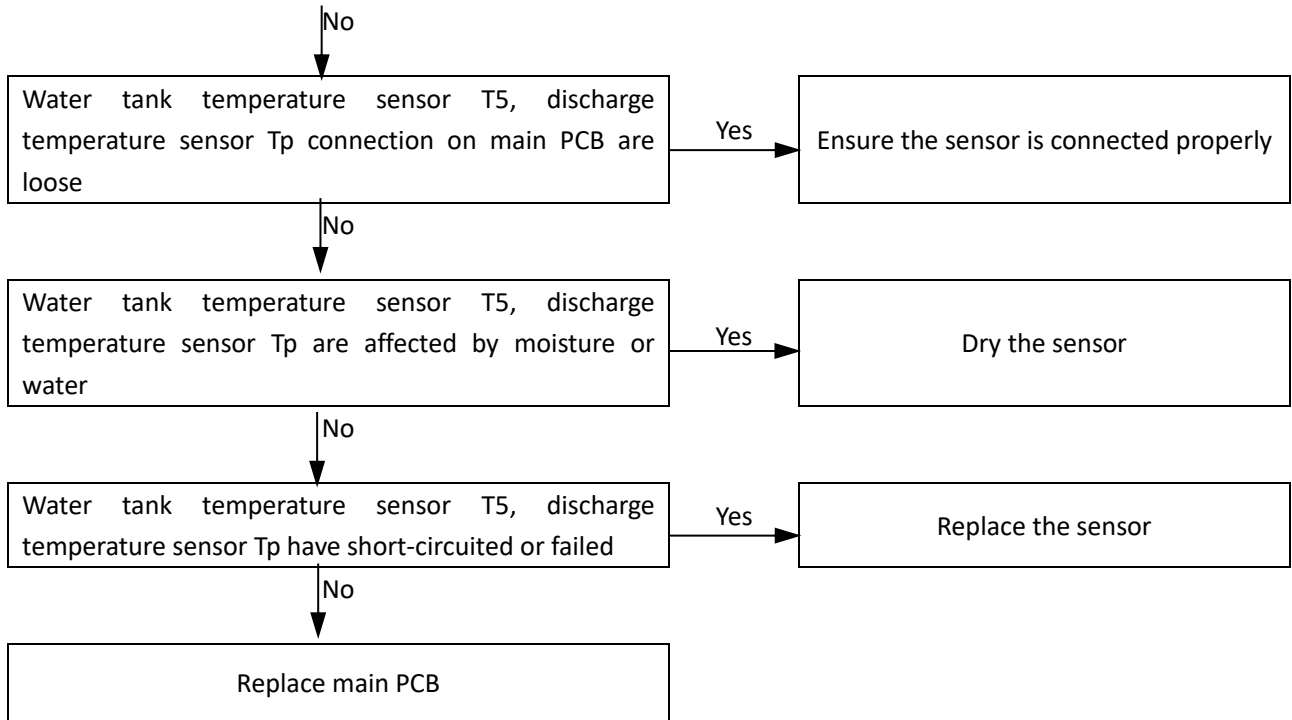
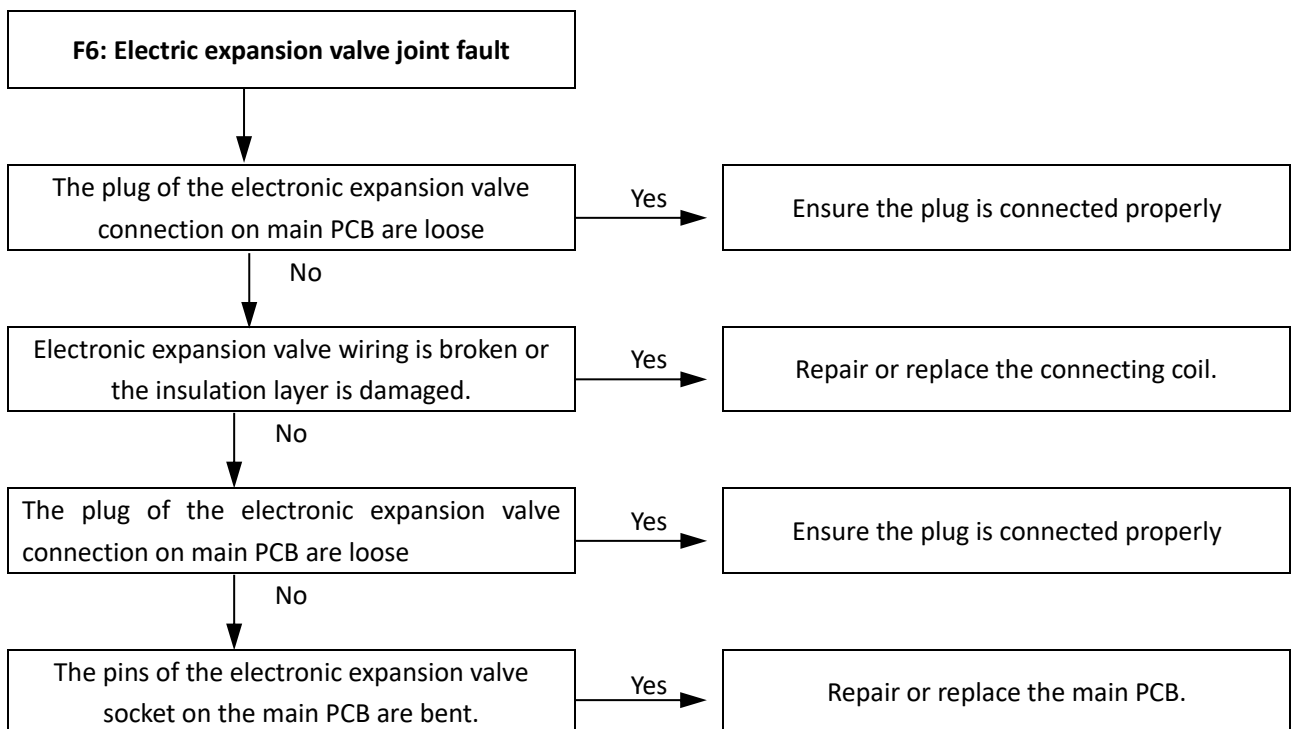

7.12 F6 Troubleshooting

7.13 HC Troubleshooting

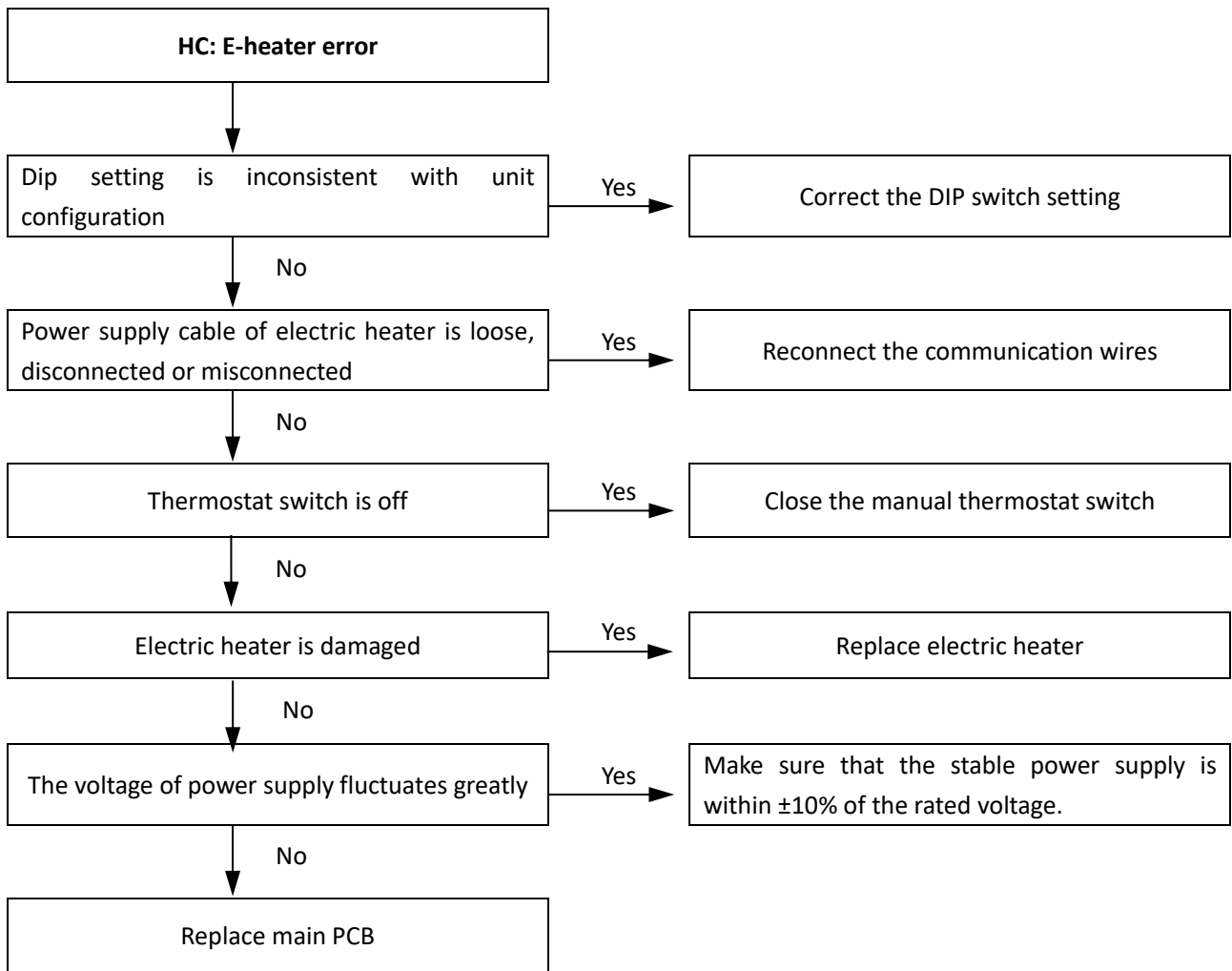
7.13.1 Procedure



7.13.2 Protection logic

Power ON or Electric heater ON

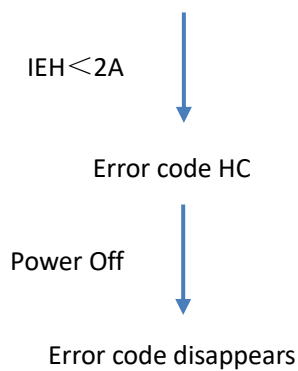

Compressor and electric heater operate

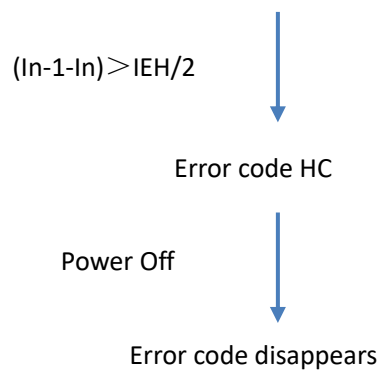

Note:

1. IEH: Electric heater current
2. I_{n-1}-I_n: Current difference between two adjacent samples

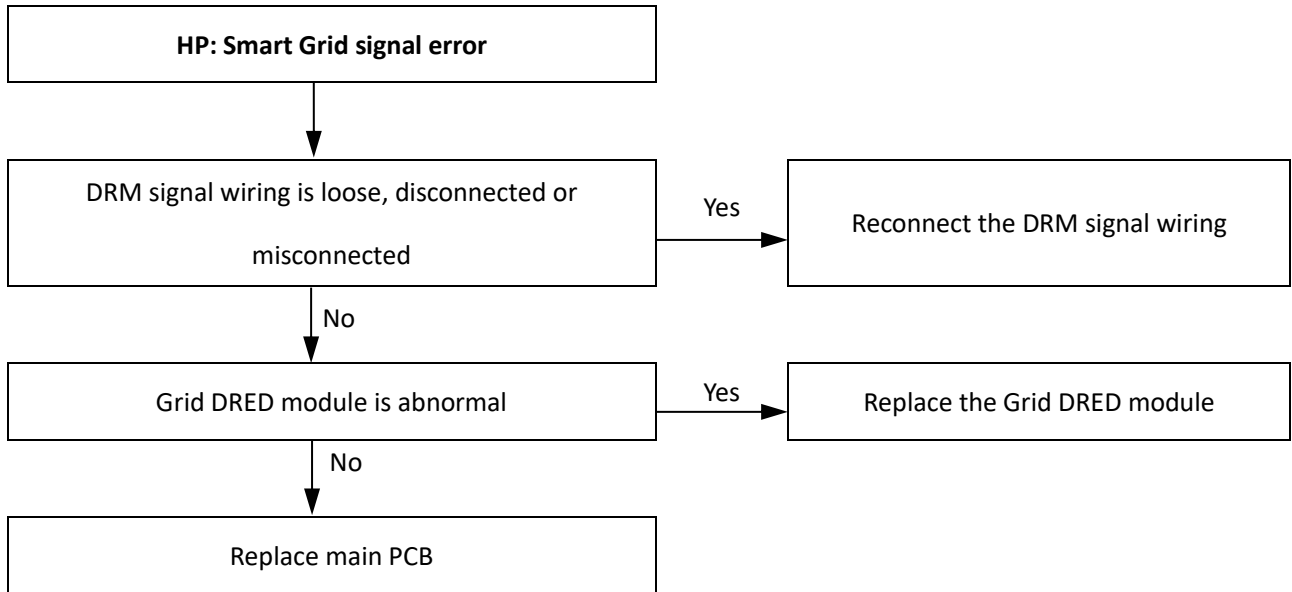
7.14 HP Troubleshooting

7.15 P0 Troubleshooting

7.15.1 Procedure

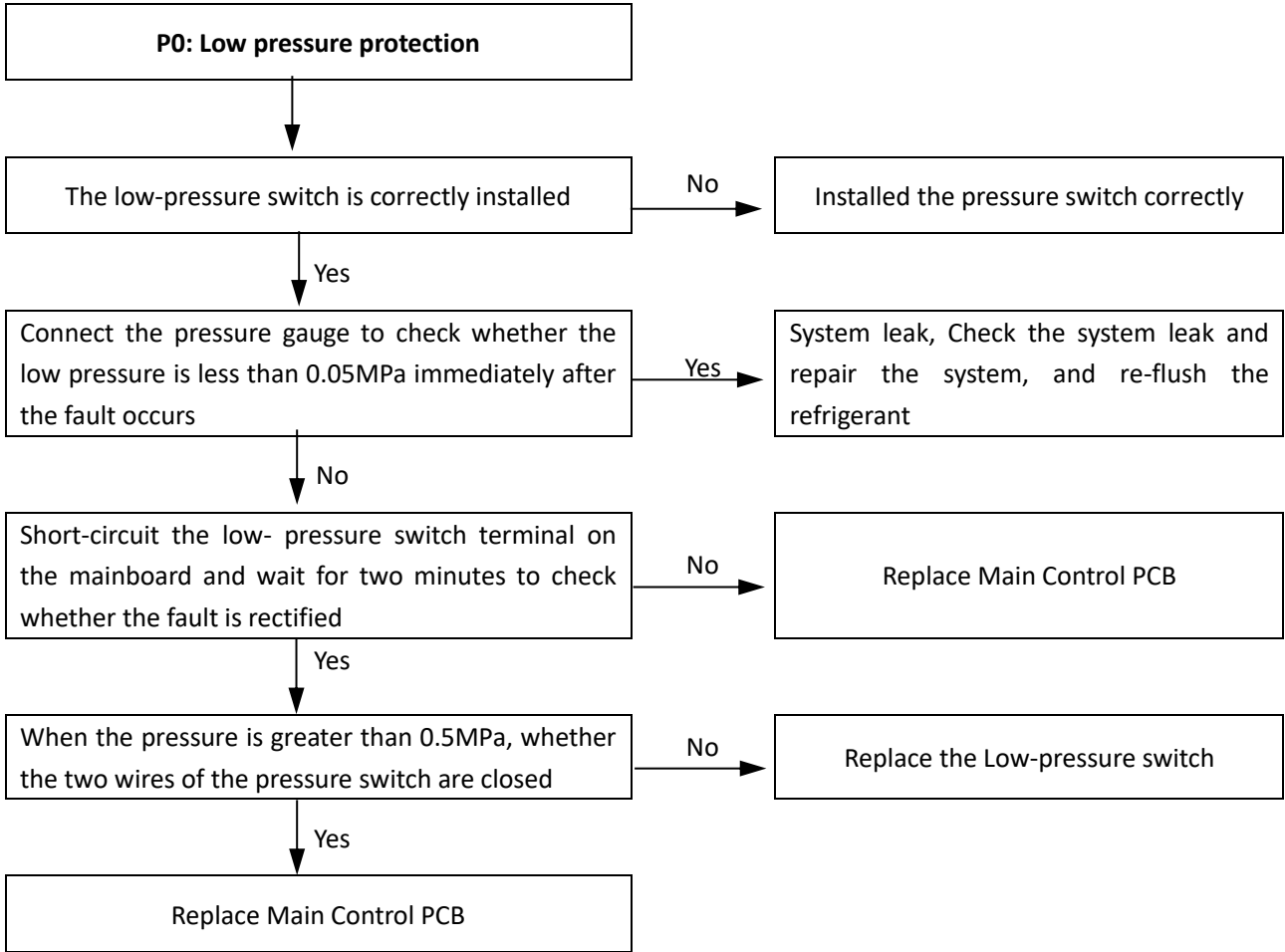

7.15.2 Protection logic

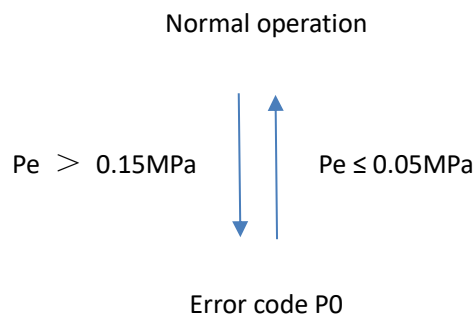

Note:

1. Pe: evaporation pressure

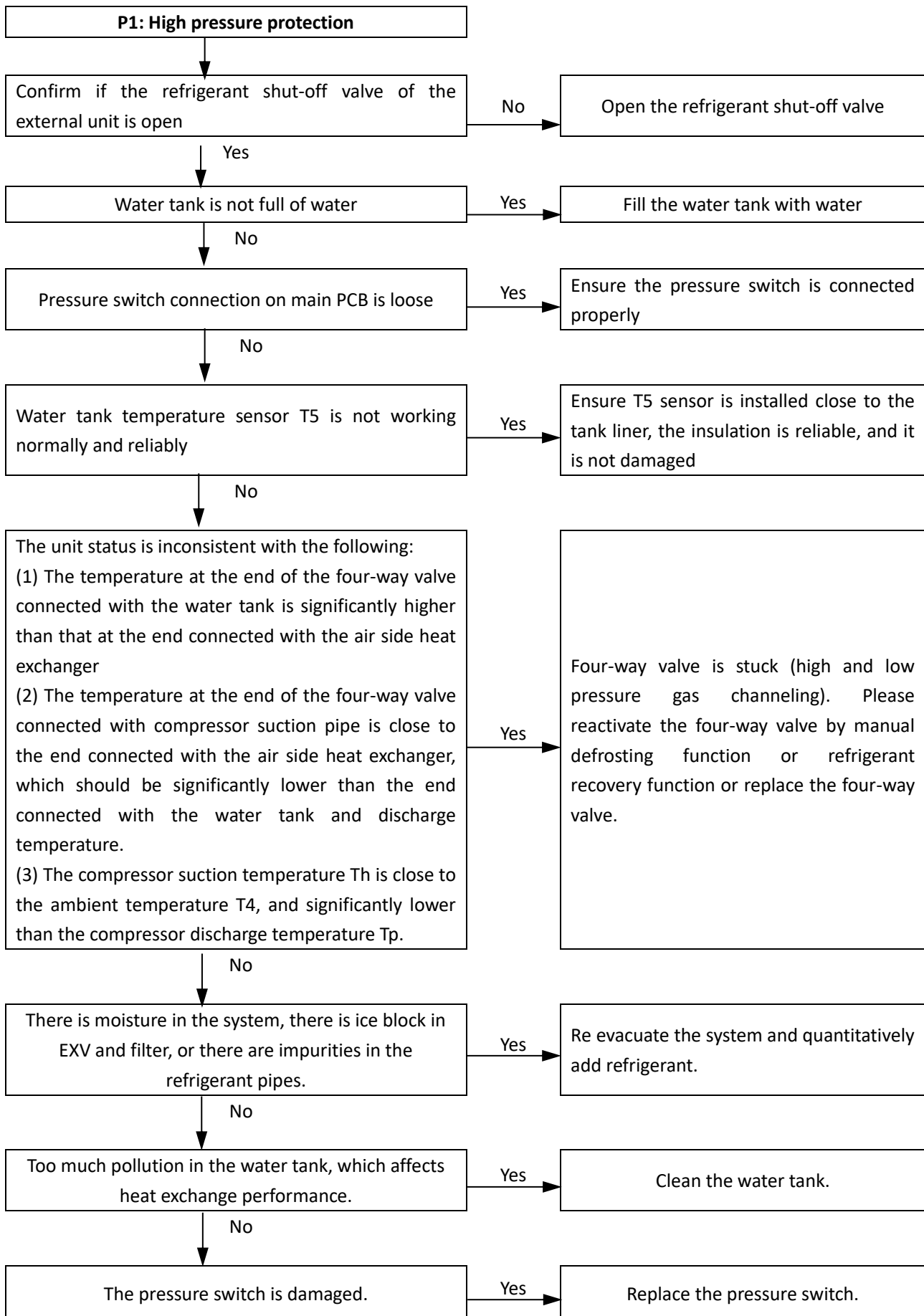
7.16 P1 Troubleshooting
7.16.1 Procedure

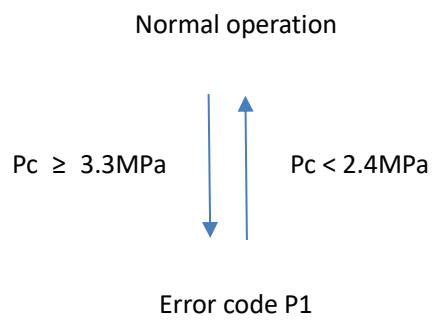
7.16.2 Protection logic

Note:

Pc: Discharge pressure

7.17 P3 Troubleshooting

7.17.1 Procedure

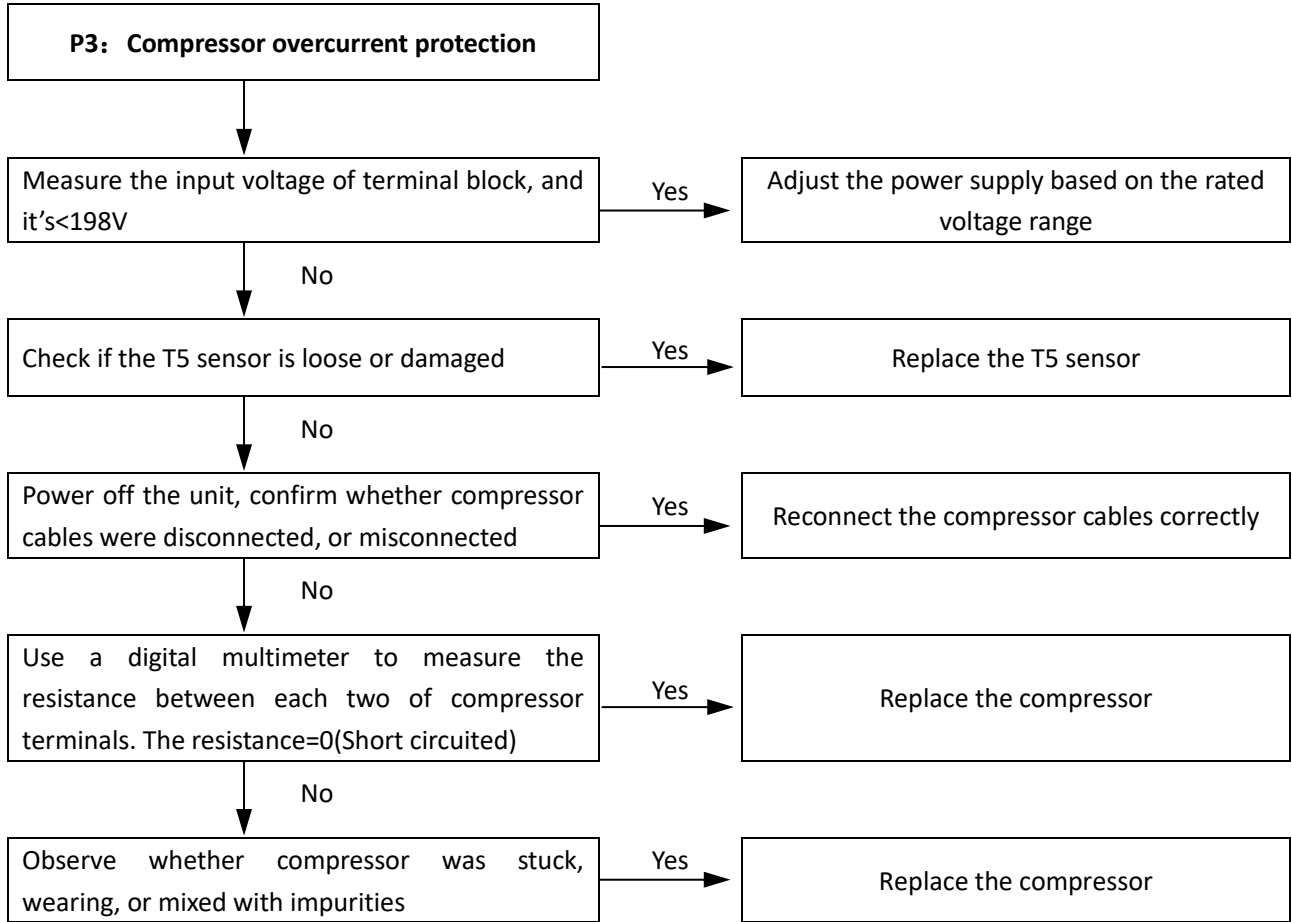

7.17.2 Protection logic

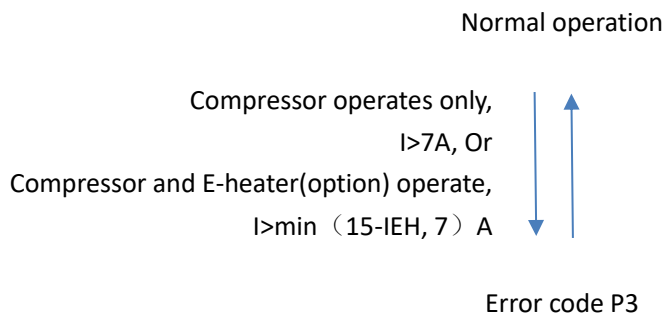

Note:

1. IEH: Electric heater current

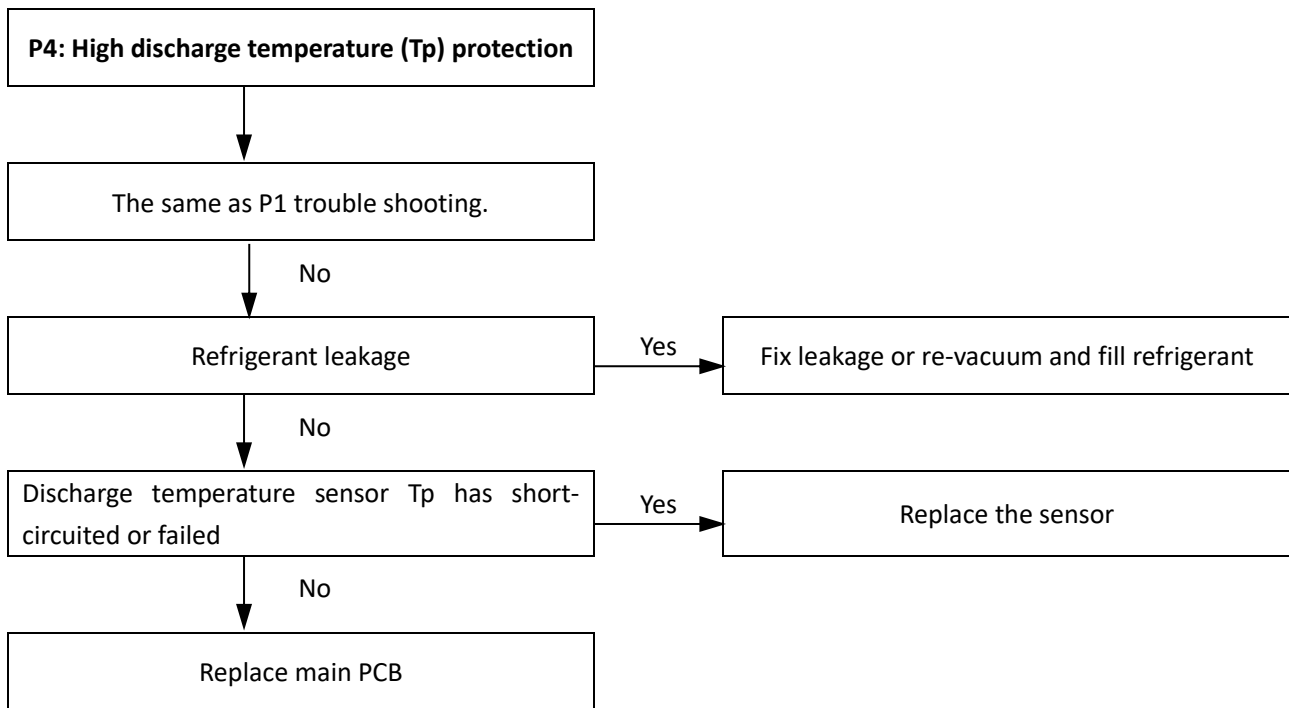
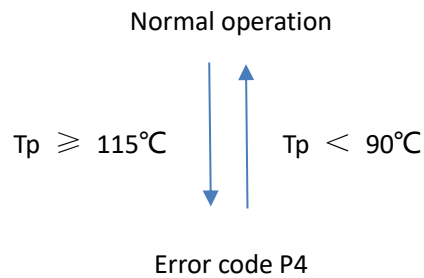
7.18 P4 Troubleshooting
7.18.1 Procedure

7.18.2 Protection logic

Note:

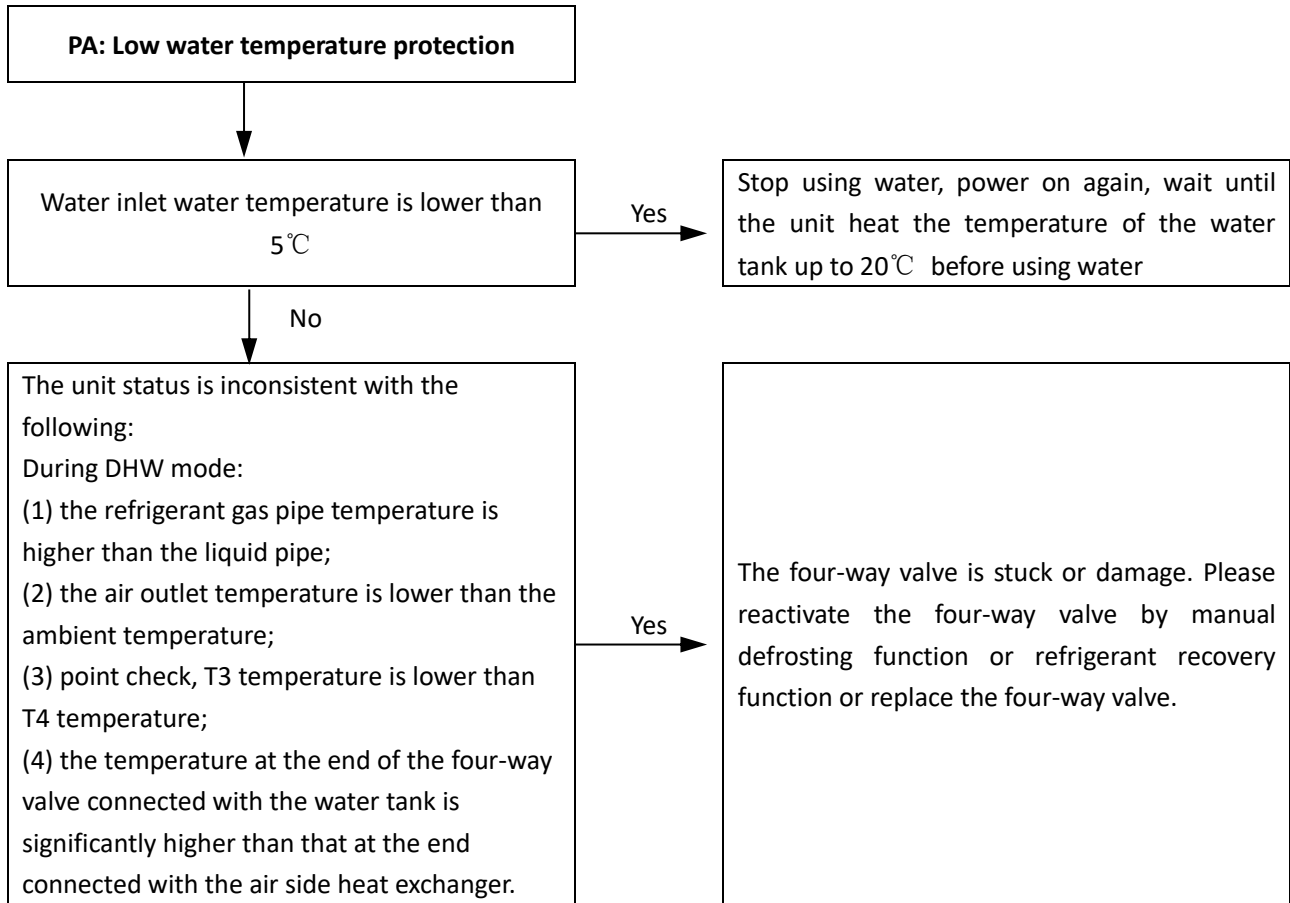
1. T_p : Compressor discharge temperature

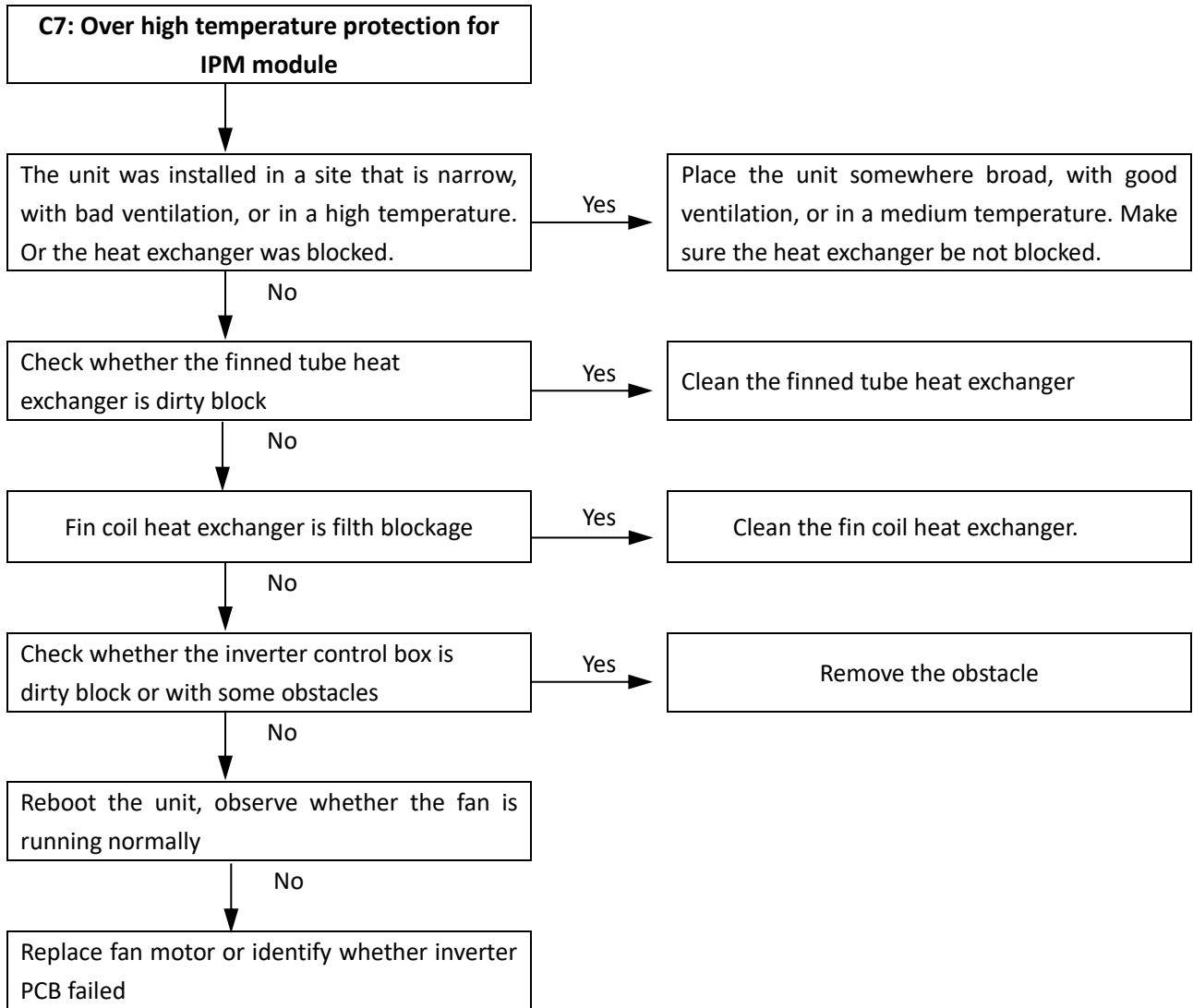
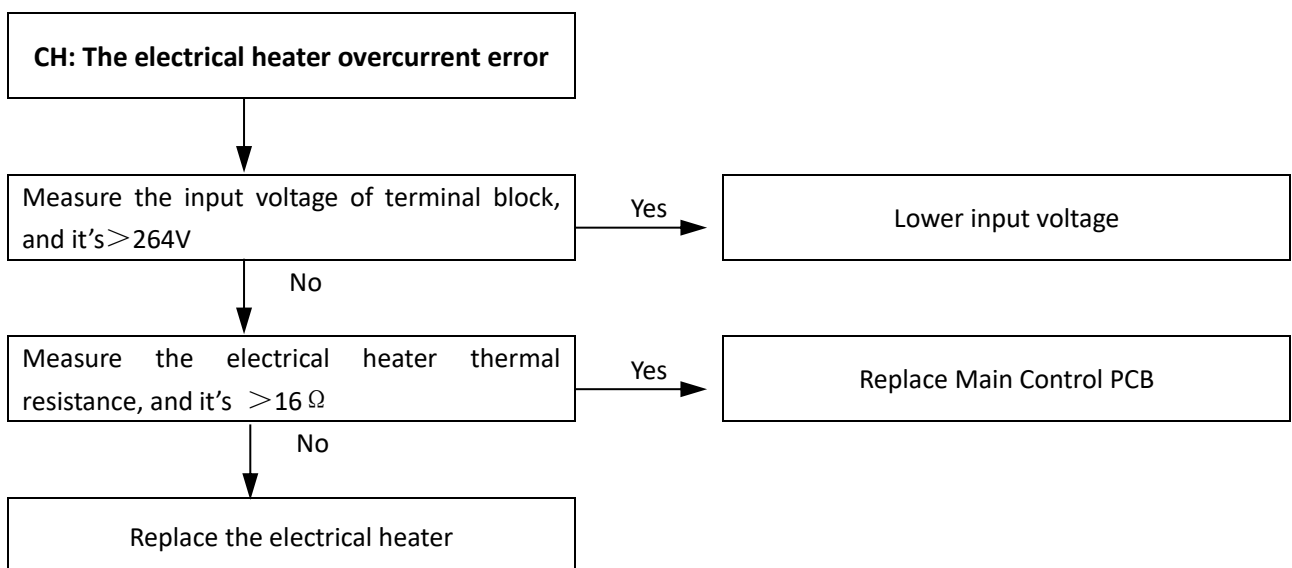
7.19 PA Troubleshooting

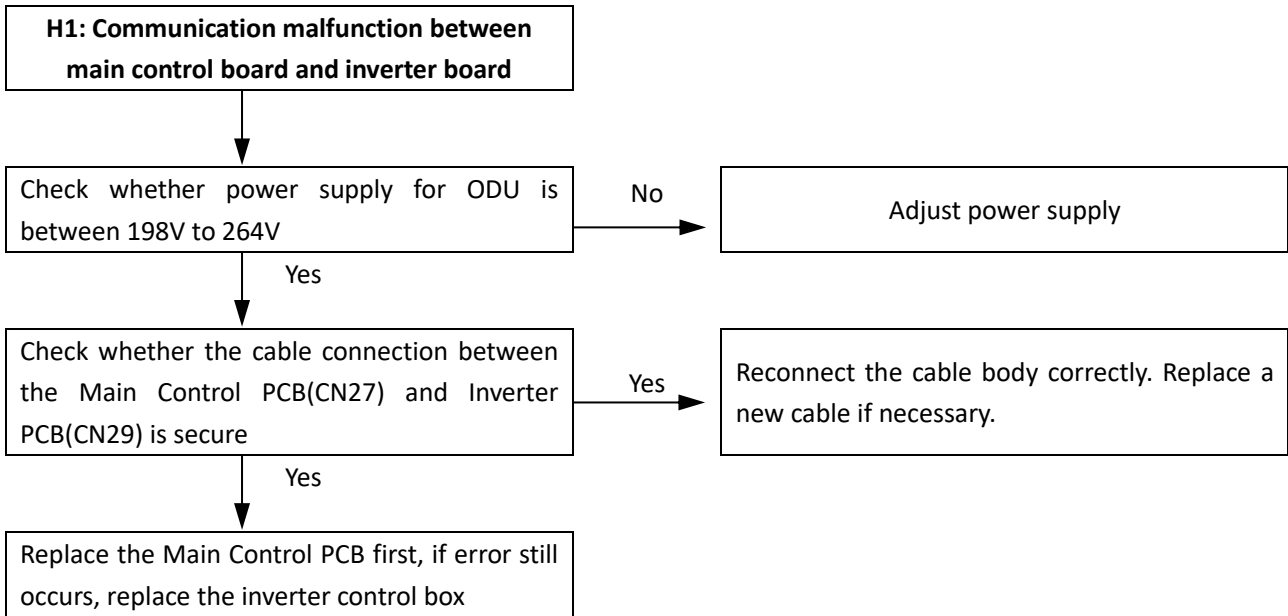
7.20 C7 Troubleshooting

7.21 CH Troubleshooting

7.22 H1 Troubleshooting

Relative ports and locations

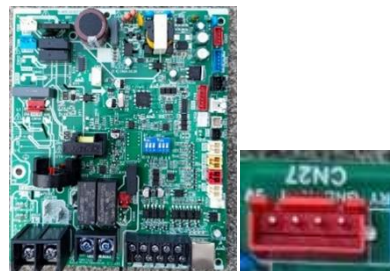
CN27 on Main Control PCB)



Port CN29 and LED101 on Inverter Module PCB



7.23 H4 Troubleshooting
7.23.1 Description
L protection occurs 3 times in an hour

Error code	Description
L0	IPM module overcurrent or weak magnetic protection (corresponding to L0x class)
L1	Module or winding high temperature protection (corresponding to L1x class)
L2	Bus voltage protection or missing phase (corresponding to L2x class)
L3	EEPROM, Driver optocoupler malfunction (upper and lower bridge), current sampling, PFC sampling bias exception (corresponding to L3x)
L4	Out of step protection
L5	Zero speed protection
L7	Phase loss, short circuit to ground, motor winding, inductance and other abnormal protection
LA	Program check class exception
Lb	PFC protection

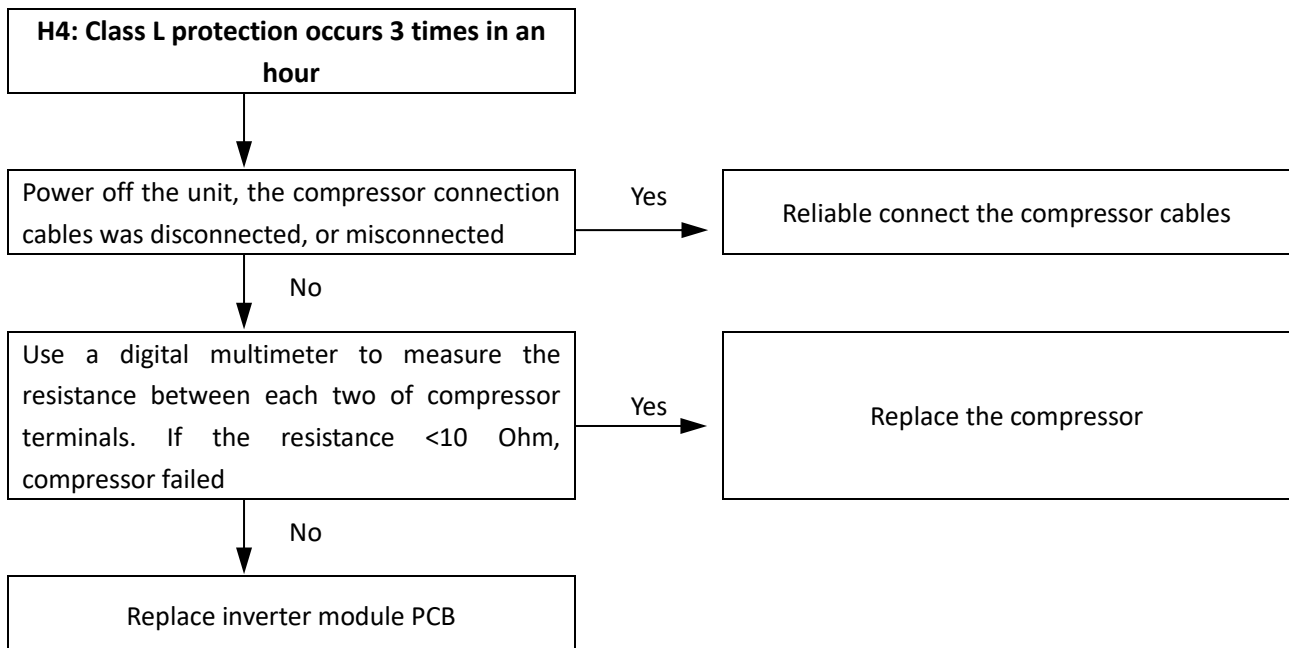
7.23.2 Procedure

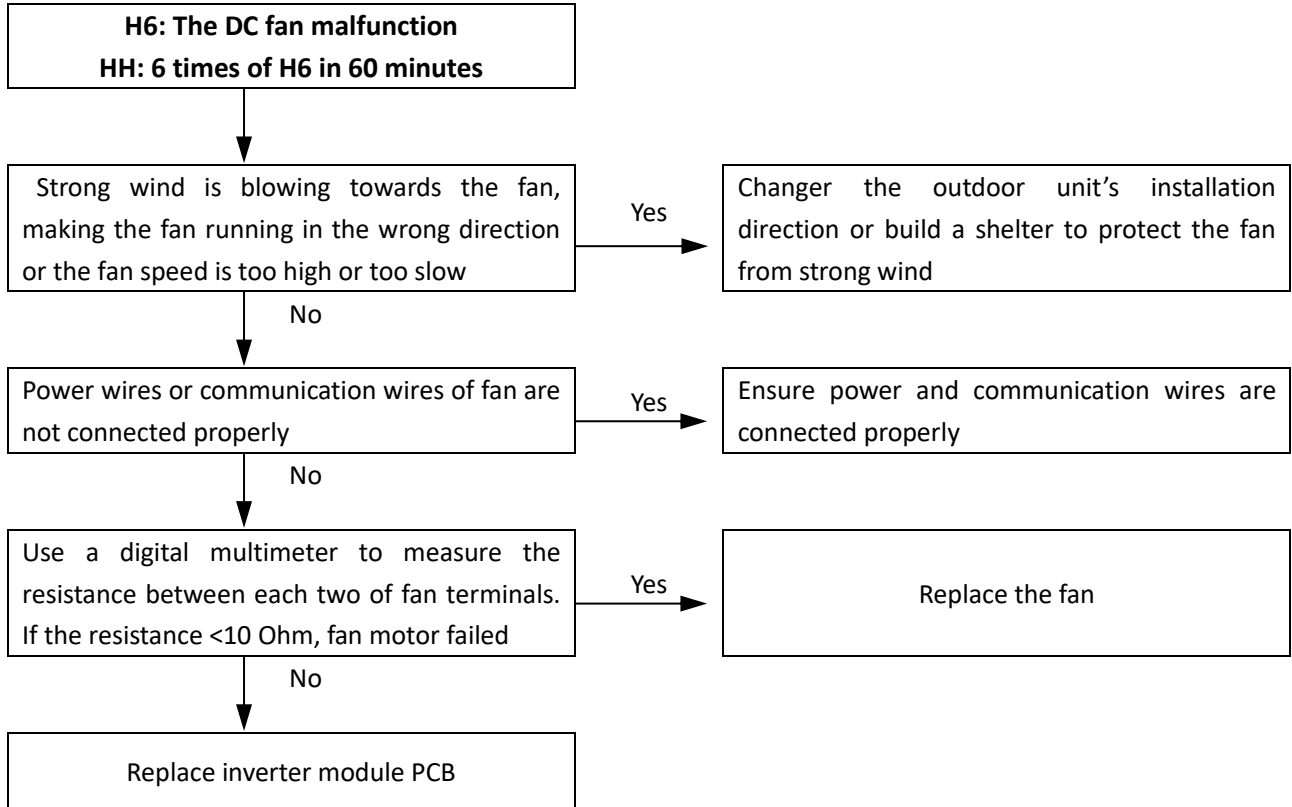
7.24 H6, HH Troubleshooting

7.25 L0, L1, L2, L3, L4, L5, L7, LA, Lb Troubleshooting
7.25.1 Description

Error code	Description
L0	IPM module overcurrent or weak magnetic protection (corresponding to L0x class)
L1	Module or winding high temperature protection (corresponding to L1x class)
L2	Bus voltage protection or missing phase (corresponding to L2x class)
L3	EEPROM, Driver optocoupler malfunction (upper and lower bridge), current sampling, PFC sampling bias exception (corresponding to L3x)
L4	Out of step protection
L5	Zero speed protection
L7	Phase loss, short circuit to ground, motor winding, inductance and other abnormal protection
LA	Program check class exception
Lb	PFC protection

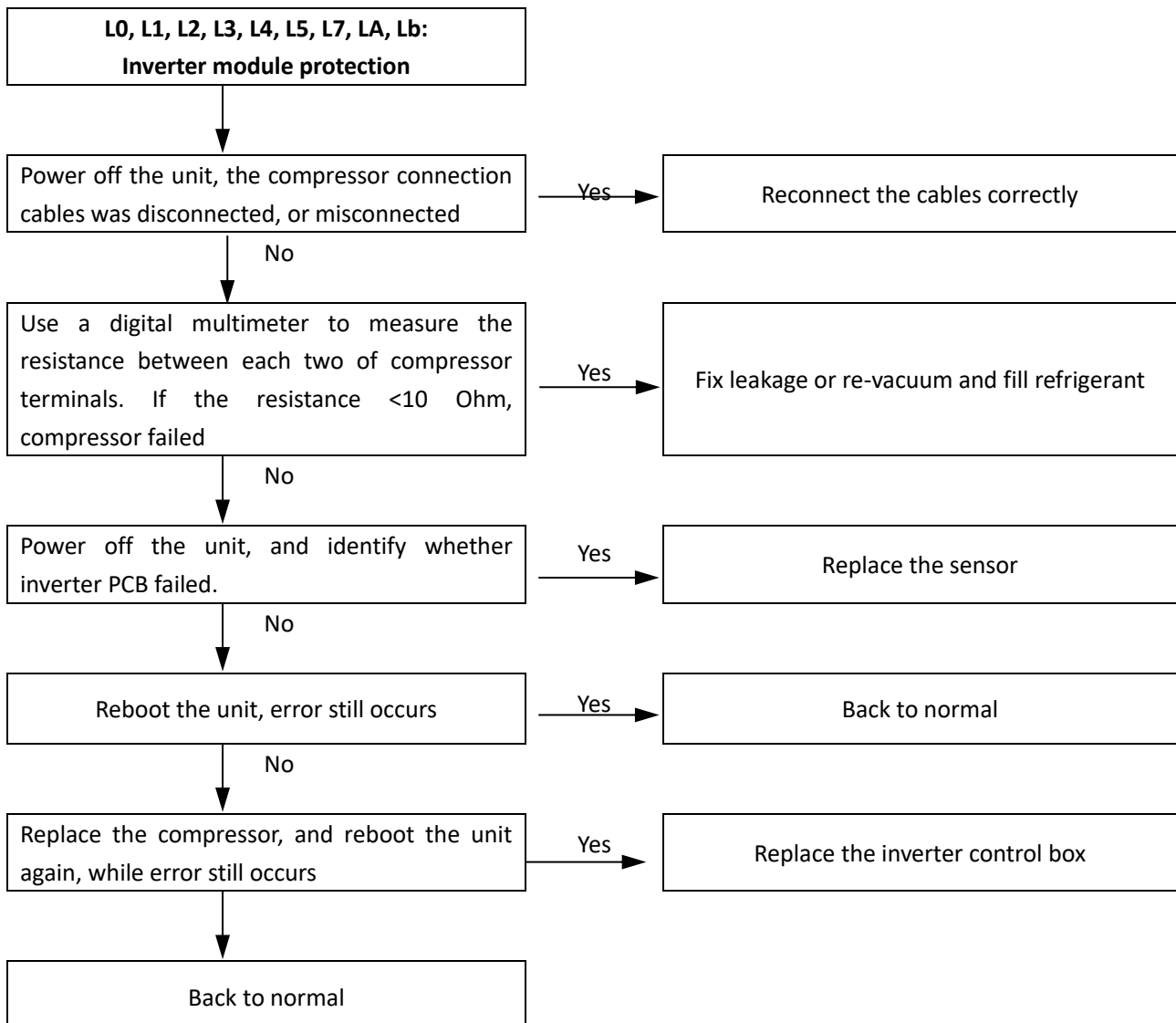
7.25.2 Procedure

8 Temperature Sensor Resistance Characteristics

Discharge temperature sensor

T(°C)	Rmin(K Ω)	Rnom(K Ω)	Rmax(K Ω)	T(°C)	Rmin(K Ω)	Rnom(K Ω)	Rmax(K Ω)
-40	1447.607	1780.010	2186.770	-3	182.421	210.390	242.429
-39	1357.115	1665.411	2041.903	-2	173.595	199.903	229.992
-38	1273.241	1559.403	1908.162	-1	165.241	189.994	218.258
-37	1195.401	1461.215	1784.530	0	157.334	180.628	207.184
-36	1123.073	1370.157	1670.097	1	149.846	171.772	196.729
-35	1055.793	1285.615	1564.057	2	142.754	163.397	186.857
-34	993.138	1207.036	1465.683	3	136.035	155.474	177.532
-33	934.733	1133.925	1374.327	4	129.667	147.978	168.721
-32	880.240	1065.838	1289.407	5	123.632	140.882	160.394
-31	829.351	1002.371	1210.396	6	117.909	134.164	152.522
-30	781.789	943.162	1136.821	7	112.481	127.802	145.078
-29	737.301	887.881	1068.252	8	107.332	121.775	138.036
-28	695.659	836.229	1004.299	9	102.447	116.064	131.373
-27	656.652	787.933	944.609	10	97.809	110.651	125.067
-26	620.092	742.746	888.861	11	93.406	105.520	119.098
-25	585.802	700.441	836.760	12	89.225	100.654	113.444
-24	553.625	660.811	788.039	13	85.253	96.038	108.090
-23	523.412	623.665	742.452	14	81.479	91.658	103.016
-22	495.030	588.830	699.774	15	77.892	87.501	98.207
-21	468.353	556.146	659.800	16	74.483	83.555	93.649
-20	443.269	525.464	622.339	17	71.240	79.808	89.326
-19	419.671	496.649	587.217	18	68.156	76.249	85.225
-18	397.461	469.575	554.273	19	65.222	72.867	81.335
-17	376.550	444.126	523.359	20	62.430	69.653	77.642
-16	356.853	420.196	494.338	21	59.772	66.598	74.137
-15	338.293	397.684	467.082	22	57.241	63.693	70.808
-14	320.799	376.500	441.475	23	54.831	60.930	67.646
-13	304.302	356.556	417.407	24	52.535	58.301	64.642
-12	288.742	337.775	394.779	25	50.346	55.799	61.787
-11	274.059	320.082	373.497	26	48.255	53.411	59.065
-10	260.200	303.408	353.473	27	46.262	51.138	56.478
-9	247.115	287.690	334.627	28	44.361	48.974	54.017
-8	234.756	272.869	316.884	29	42.549	46.912	51.676
-7	223.080	258.888	300.175	30	40.819	44.947	49.449
-6	212.045	245.697	284.433	31	39.169	43.075	47.329
-5	201.614	233.246	269.598	32	37.594	41.291	45.310
-4	191.751	221.491	255.615	33	36.091	39.590	43.389

T(°C)	Rmin(K Ω)	Rnom(K Ω)	Rmax(K Ω)	T(°C)	Rmin(K Ω)	Rnom(K Ω)	Rmax(K Ω)
34	34.655	37.967	41.558	74	8.048	8.427	8.817
35	33.284	36.419	39.814	75	7.788	8.147	8.515
36	31.973	34.942	38.152	76	7.537	7.877	8.225
37	30.722	33.533	36.568	77	7.297	7.618	7.946
38	29.525	32.187	35.057	78	7.064	7.368	7.678
39	28.381	30.902	33.617	79	6.841	7.128	7.420
40	27.288	29.675	32.243	80	6.625	6.896	7.172
41	26.242	28.503	30.932	81	6.417	6.673	6.933
42	25.241	27.383	29.681	82	6.217	6.458	6.704
43	24.283	26.313	28.487	83	6.024	6.252	6.483
44	23.367	25.290	27.347	84	5.837	6.053	6.270
45	22.490	24.312	26.258	85	5.658	5.861	6.065
46	21.650	23.376	25.218	86	5.485	5.676	5.868
47	20.845	22.481	24.224	87	5.317	5.497	5.678
48	20.075	21.625	23.274	88	5.156	5.325	5.496
49	19.337	20.806	22.367	89	5.000	5.160	5.320
50	18.629	20.022	21.499	90	4.850	5.000	5.150
51	17.951	19.271	20.669	91	4.696	4.846	4.996
52	17.301	18.552	19.875	92	4.548	4.697	4.847
53	16.678	17.863	19.116	93	4.405	4.554	4.703
54	16.080	17.204	18.389	94	4.267	4.415	4.565
55	15.507	16.572	17.693	95	4.134	4.282	4.431
56	14.957	15.966	17.028	96	4.006	4.153	4.301
57	14.429	15.385	16.390	97	3.882	4.028	4.176
58	13.922	14.828	15.779	98	3.763	3.908	4.055
59	13.435	14.294	15.194	99	3.648	3.792	3.938
60	12.968	13.782	14.634	100	3.537	3.680	3.825
61	12.519	13.291	14.097	101	3.430	3.572	3.716
62	12.089	12.819	13.582	102	3.326	3.467	3.610
63	11.674	12.367	13.089	103	3.226	3.366	3.508
64	11.277	11.933	12.616	104	3.130	3.268	3.409
65	10.894	11.516	12.162	105	3.037	3.174	3.314
66	10.527	11.115	11.727	106	2.947	3.082	3.221
67	10.173	10.731	11.309	107	2.860	2.994	3.132
68	9.833	10.361	10.908	108	2.776	2.909	3.045
69	9.506	10.006	10.523	109	2.695	2.826	2.961
70	9.192	9.665	10.154	110	2.617	2.746	2.880
71	8.889	9.337	9.799	111	2.541	2.669	2.802
72	8.598	9.022	9.459	112	2.468	2.594	2.725
73	8.317	8.719	9.132	113	2.397	2.522	2.652

T(°C)	Rmin(K Ω)	Rnom(K Ω)	Rmax(K Ω)	T(°C)	Rmin(K Ω)	Rnom(K Ω)	Rmax(K Ω)
114	2.328	2.452	2.580	153	0.841	0.912	0.989
115	2.262	2.384	2.511	154	0.825	0.896	0.972
116	2.198	2.319	2.444	155	0.810	0.880	0.955
117	2.136	2.255	2.379	156	0.795	0.864	0.938
118	2.076	2.194	2.316	157	0.780	0.848	0.921
119	2.018	2.134	2.255	158	0.765	0.833	0.905
120	1.962	2.077	2.196	159	0.751	0.818	0.889
121	1.908	2.021	2.139	160	0.737	0.803	0.873
122	1.855	1.967	2.083	161	0.723	0.788	0.858
123	1.804	1.914	2.029	162	0.709	0.773	0.842
124	1.755	1.863	1.977	163	0.696	0.759	0.827
125	1.707	1.814	1.926	164	0.683	0.745	0.812
126	1.661	1.766	1.877	165	0.669	0.731	0.798
127	1.616	1.720	1.829	166	0.657	0.717	0.783
128	1.573	1.675	1.783	167	0.644	0.704	0.769
129	1.531	1.632	1.738	168	0.631	0.691	0.755
130	1.490	1.590	1.695	169	0.619	0.678	0.741
131	1.450	1.549	1.652	170	0.607	0.665	0.728
132	1.412	1.509	1.611	171	0.595	0.652	0.714
133	1.375	1.470	1.571	172	0.584	0.640	0.701
134	1.339	1.433	1.532	173	0.572	0.628	0.688
135	1.304	1.397	1.495	174	0.561	0.616	0.675
136	1.270	1.361	1.458	175	0.550	0.604	0.662
137	1.237	1.327	1.423	176	0.539	0.592	0.650
138	1.205	1.294	1.388	177	0.528	0.581	0.638
139	1.175	1.262	1.355	178	0.517	0.569	0.626
140	1.145	1.231	1.322	179	0.507	0.558	0.614
141	1.115	1.200	1.290	180	0.497	0.547	0.602
142	1.087	1.171	1.260	181	0.486	0.536	0.591
143	1.060	1.142	1.230	182	0.477	0.526	0.579
144	1.033	1.114	1.201	183	0.467	0.515	0.568
145	1.007	1.087	1.172	184	0.457	0.505	0.557
146	0.982	1.061	1.145	185	0.448	0.495	0.546
147	0.958	1.035	1.118	186	0.439	0.485	0.536
148	0.934	1.011	1.092	187	0.430	0.475	0.525
149	0.911	0.987	1.067	188	0.421	0.466	0.515
150	0.889	0.963	1.042	189	0.412	0.456	0.505
151	0.873	0.946	1.024	190	0.403	0.447	0.495
152	0.857	0.929	1.006				

Air side heat exchanger temperature sensor, ambient temperature sensor, suction temperature sensor

T(°C)	Rmin(K Ω)	Rnom(K Ω)	Rmax(K Ω)	T(°C)	Rmin(K Ω)	Rnom(K Ω)	Rmax(K Ω)
-40	337.762	388.619	446.732	-3	37.558	40.376	43.365
-39	315.441	362.171	415.450	-2	35.647	38.259	41.025
-38	294.802	337.767	386.646	-1	33.843	36.264	38.824
-37	275.699	315.226	360.096	0	32.140	34.385	36.753
-36	258.001	294.386	335.600	1	30.532	32.613	34.803
-35	241.589	275.100	312.977	2	29.013	30.941	32.968
-34	226.358	257.238	292.067	3	27.578	29.364	31.238
-33	212.210	240.679	272.721	4	26.221	27.876	29.609
-32	199.059	225.317	254.809	5	24.938	26.471	28.074
-31	186.823	211.053	238.210	6	23.725	25.145	26.626
-30	175.432	197.799	222.817	7	22.578	23.892	25.260
-29	164.820	185.475	208.531	8	21.492	22.708	23.972
-28	154.925	174.007	195.264	9	20.464	21.590	22.757
-27	145.695	163.330	182.934	10	19.491	20.532	21.609
-26	137.078	153.381	171.467	11	18.569	19.532	20.526
-25	129.030	144.105	160.797	12	17.696	18.586	19.502
-24	121.508	135.452	150.861	13	16.868	17.690	18.536
-23	114.473	127.375	141.604	14	16.084	16.843	17.622
-22	107.892	119.832	132.974	15	15.341	16.041	16.758
-21	101.730	112.783	124.925	16	14.635	15.281	15.941
-20	95.959	106.193	117.413	17	13.966	14.562	15.169
-19	90.551	100.028	110.399	18	13.332	13.880	14.438
-18	85.480	94.259	103.846	19	12.729	13.234	13.746
-17	80.724	88.857	97.721	20	12.157	12.621	13.091
-16	76.260	83.796	91.994	21	11.614	12.041	12.471
-15	72.070	79.054	86.636	22	11.099	11.490	11.884
-14	68.134	74.607	81.620	23	10.608	10.967	11.327
-13	64.436	70.436	76.924	24	10.143	10.471	10.800
-12	60.960	66.521	72.525	25	9.700	10.000	10.300
-11	57.691	62.847	68.402	26	9.254	9.553	9.853
-10	54.615	59.396	64.536	27	8.830	9.128	9.428
-9	51.721	56.153	60.911	28	8.429	8.725	9.024
-8	48.996	53.106	57.509	29	8.048	8.342	8.639
-7	46.430	50.241	54.315	30	7.686	7.977	8.273
-6	44.012	47.546	51.317	31	7.342	7.631	7.924
-5	41.733	45.010	48.500	32	7.016	7.302	7.592
-4	39.585	42.623	45.853	33	6.706	6.988	7.276

T(°C)	Rmin(K Ω)	Rnom(K Ω)	Rmax(K Ω)	T(°C)	Rmin(K Ω)	Rnom(K Ω)	Rmax(K Ω)
34	6.412	6.690	6.975	71	1.455	1.585	1.725
35	6.132	6.407	6.688	72	1.403	1.530	1.668
36	5.866	6.137	6.414	73	1.354	1.478	1.613
37	5.613	5.880	6.153	74	1.307	1.428	1.559
38	5.373	5.635	5.905	75	1.261	1.380	1.509
39	5.144	5.402	5.667	76	1.218	1.334	1.460
40	4.926	5.179	5.441	77	1.176	1.289	1.412
41	4.718	4.968	5.225	78	1.136	1.247	1.367
42	4.521	4.766	5.019	79	1.098	1.206	1.323
43	4.333	4.573	4.822	80	1.060	1.166	1.281
44	4.154	4.390	4.634	81	1.025	1.128	1.240
45	3.983	4.215	4.455	82	0.990	1.091	1.201
46	3.821	4.047	4.283	83	0.958	1.056	1.164
47	3.666	3.888	4.120	84	0.926	1.022	1.127
48	3.518	3.736	3.963	85	0.895	0.990	1.092
49	3.377	3.590	3.813	86	0.866	0.958	1.059
50	3.243	3.451	3.670	87	0.838	0.928	1.026
51	3.114	3.318	3.533	88	0.811	0.899	0.995
52	2.991	3.192	3.402	89	0.785	0.870	0.965
53	2.874	3.070	3.276	90	0.760	0.843	0.935
54	2.762	2.954	3.156	91	0.735	0.817	0.907
55	2.656	2.843	3.041	92	0.712	0.792	0.880
56	2.553	2.737	2.931	93	0.689	0.768	0.854
57	2.456	2.635	2.825	94	0.668	0.744	0.829
58	2.362	2.538	2.723	95	0.647	0.722	0.804
59	2.273	2.444	2.626	96	0.627	0.700	0.781
60	2.187	2.355	2.533	97	0.607	0.679	0.758
61	2.105	2.269	2.444	98	0.589	0.659	0.736
62	2.027	2.187	2.358	99	0.571	0.639	0.715
63	1.952	2.109	2.276	100	0.553	0.620	0.694
64	1.880	2.033	2.197	101	0.537	0.602	0.674
65	1.811	1.961	2.121	102	0.520	0.584	0.655
66	1.745	1.892	2.048	103	0.505	0.567	0.637
67	1.682	1.825	1.978	104	0.490	0.551	0.619
68	1.622	1.761	1.911	105	0.475	0.535	0.602
69	1.564	1.700	1.847	106	0.461	0.520	0.585
70	1.508	1.641	1.785	107	0.448	0.505	0.569

T(°C)	Rmin(K Ω)	Rnom(K Ω)	Rmax(K Ω)	T(°C)	Rmin(K Ω)	Rnom(K Ω)	Rmax(K Ω)
108	0.434	0.490	0.553	145	0.160	0.186	0.216
109	0.422	0.477	0.538	146	0.156	0.181	0.211
110	0.410	0.463	0.523	147	0.152	0.177	0.206
111	0.398	0.450	0.509	148	0.148	0.173	0.201
112	0.386	0.438	0.495	149	0.145	0.169	0.197
113	0.375	0.425	0.482	150	0.142	0.165	0.192
114	0.365	0.414	0.469				
115	0.354	0.402	0.456				
116	0.344	0.391	0.444				
117	0.335	0.381	0.433				
118	0.325	0.370	0.421				
119	0.317	0.361	0.410				
120	0.308	0.351	0.400				
121	0.299	0.342	0.389				
122	0.291	0.332	0.379				
123	0.283	0.324	0.370				
124	0.276	0.315	0.360				
125	0.268	0.307	0.351				
126	0.261	0.299	0.342				
127	0.254	0.291	0.334				
128	0.247	0.284	0.325				
129	0.241	0.277	0.317				
130	0.234	0.269	0.309				
131	0.228	0.263	0.302				
132	0.222	0.256	0.294				
133	0.217	0.250	0.287				
134	0.211	0.243	0.280				
135	0.206	0.237	0.273				
136	0.200	0.231	0.267				
137	0.195	0.226	0.260				
138	0.190	0.220	0.254				
139	0.186	0.215	0.248				
140	0.181	0.210	0.242				
141	0.177	0.205	0.237				
142	0.172	0.200	0.231				
143	0.168	0.195	0.226				
144	0.164	0.190	0.221				

Water tank temperature sensor

T(°C)	Rmin(K Ω)	Rnom(K Ω)	Rmax(K Ω)	T(°C)	Rmin(K Ω)	Rnom(K Ω)	Rmax(K Ω)
-30	809.991	896.2577	990.820	7	106.888	113.9619	121.395
-29	761.426	841.5665	929.304	8	101.845	108.4893	115.463
-28	716.109	790.5898	872.032	9	97.069	103.3107	109.855
-27	673.799	743.0496	818.680	10	92.544	98.4086	104.550
-26	634.276	698.6900	768.953	11	88.256	93.7668	99.532
-25	597.337	657.2758	722.579	12	84.190	89.3703	94.783
-24	562.794	618.5909	679.308	13	80.335	85.2048	90.288
-23	530.475	582.4368	638.912	14	76.679	81.2570	86.031
-22	500.224	548.6316	601.182	15	73.209	77.5143	81.999
-21	471.894	517.0065	565.922	16	69.916	73.9652	78.179
-20	445.349	487.4069	532.956	17	66.790	70.5986	74.558
-19	420.467	459.6901	502.120	18	63.821	67.4043	71.125
-18	397.132	433.7241	473.262	19	61.001	64.3725	67.870
-17	375.238	409.3871	446.242	20	58.321	61.4941	64.781
-16	354.688	386.5674	420.933	21	55.774	58.7607	61.851
-15	335.390	365.1602	397.215	22	53.353	56.1642	59.070
-14	317.260	345.0701	374.980	23	51.051	53.6971	56.430
-13	300.222	326.2077	354.124	24	48.861	51.3522	53.922
-12	284.202	308.4907	334.554	25	46.777	49.1230	51.540
-11	269.133	291.8429	316.184	26	44.794	47.0031	49.277
-10	254.954	276.1933	298.932	27	42.906	44.9867	47.126
-9	241.607	261.4764	282.725	28	41.109	43.0682	45.081
-8	229.038	247.6312	267.493	29	39.397	41.2423	43.136
-7	217.198	234.6010	253.171	30	37.765	39.5042	41.286
-6	206.039	222.3332	239.700	31	36.211	37.8491	39.526
-5	195.519	210.7789	227.025	32	34.730	36.2728	37.850
-4	185.598	199.8927	215.094	33	33.317	34.7710	36.256
-3	176.238	189.6322	203.860	34	31.970	33.3400	34.737
-2	167.405	179.9580	193.278	35	30.685	31.9759	33.291
-1	159.066	170.8333	183.306	36	29.459	30.6754	31.913
0	151.190	162.2240	173.906	37	28.289	29.4352	30.600
1	143.750	154.0982	165.043	38	27.172	28.2522	29.349
2	136.719	146.4261	156.681	39	26.106	27.1234	28.155
3	130.072	139.1800	148.792	40	25.087	26.0462	27.018
4	123.786	132.3339	141.345	41	24.114	25.0179	25.932
5	117.840	125.8637	134.313	42	23.185	24.0361	24.896
6	112.214	119.7467	127.670	43	22.296	23.0984	23.908

44	21.447	22.2026	22.965	81	5.636	5.9252	6.224
45	20.634	21.3467	22.064	82	5.454	5.7373	6.030
46	19.858	20.5287	21.203	83	5.279	5.5563	5.843
47	19.115	19.7468	20.381	84	5.110	5.3818	5.663
48	18.404	18.9991	19.596	85	4.948	5.2137	5.489
49	17.723	18.2840	18.845	86	4.791	5.0516	5.321
50	17.072	17.6000	18.128	87	4.640	4.8954	5.160
51	16.423	16.9427	17.463	88	4.495	4.7448	5.004
52	15.802	16.3134	16.826	89	4.355	4.5995	4.853
53	15.208	15.7107	16.215	90	4.220	4.4594	4.708
54	14.640	15.1335	15.630	91	4.090	4.3242	4.568
55	14.095	14.5806	15.069	92	3.964	4.1937	4.432
56	13.574	14.0507	14.531	93	3.843	4.0679	4.302
57	13.075	13.5428	14.015	94	3.726	3.9464	4.176
58	12.596	13.0559	13.520	95	3.614	3.8291	4.054
59	12.138	12.5890	13.045	96	3.505	3.7158	3.936
60	11.699	12.1413	12.589	97	3.400	3.6064	3.822
61	11.277	11.7118	12.152	98	3.298	3.5008	3.712
62	10.874	11.2996	11.732	99	3.201	3.3988	3.606
63	10.486	10.9041	11.328	100	3.106	3.3002	3.503
64	10.115	10.5245	10.941	101	3.015	3.2049	3.404
65	9.758	10.1600	10.569	102	2.927	3.1129	3.308
66	9.416	9.8100	10.211	103	2.842	3.0239	3.215
67	9.088	9.4738	9.867	104	2.759	2.9379	3.125
68	8.772	9.1508	9.537	105	2.680	2.8547	3.038
69	8.470	8.8405	9.219				
70	8.179	8.5423	8.914				
71	7.900	8.2556	8.620				
72	7.631	7.9800	8.337				
73	7.373	7.7150	8.065				
74	7.125	7.4600	7.803				
75	6.887	7.2148	7.551				
76	6.658	6.9789	7.309				
77	6.437	6.7518	7.075				
78	6.225	6.5333	6.850				
79	6.021	6.3229	6.634				
80	5.825	6.1203	6.425				

NOTE CONCERNING PROTECTION OF ENVIRONMENT



This product must not be disposed of via normal household waste after its service life, but must be taken to a collection station for the recycling of electrical and electronic devices. The symbol on the product, the operating instructions or the packaging indicate such disposal procedures. The materials are recyclable in accordance with their respective symbols. By means of re-use, material recycling or any other form of recycling old appliances you are making an important contribution to the protection of our environment. Please ask your local council where your nearest disposal station is located.

INFORMATION CONCERNING USED REFRIGERANT MEDIUM

This unit is containing fluorinated gases included in the Kyoto protocol.

The maintenance and the liquidation must be carried out by qualified personnel.

The composition of the cooling medium R410a: (78.5% HFO-1234yf, 21.5% HFC-32)

Type of refrigerant: R454C

The quantity of the refrigerant: Please see the unit label.

The value GWP: 148 (1 kg R454C = 0,148 t CO₂ eq)

GWP = Global Warming Potential



Appliance filled with flammable gas R454C.

In case of quality problem or other please contact your local supplier or authorized service center.

Emergency number: 112

PRODUCER

SINCLAIR CORPORATION Ltd.

16 Great Queen Street

WC2B 5AH London

United Kingdom

www.sinclair-world.com

This product was manufactured in China (Made in China).

REPRESENTATIVE

SINCLAIR Global Group s.r.o.

Purkynova 45

612 00 Brno

Czech Republic

TECHNICAL SUPPORT

SINCLAIR Global Group s.r.o.

Purkynova 45

612 00 Brno

Czech Republic

Tel.: +420 800 100 285 | Fax: +420 541 590 124

www.sinclair-solutions.com | info@sinclair-solutions.com

