

USER & INSTALLATION MANUAL

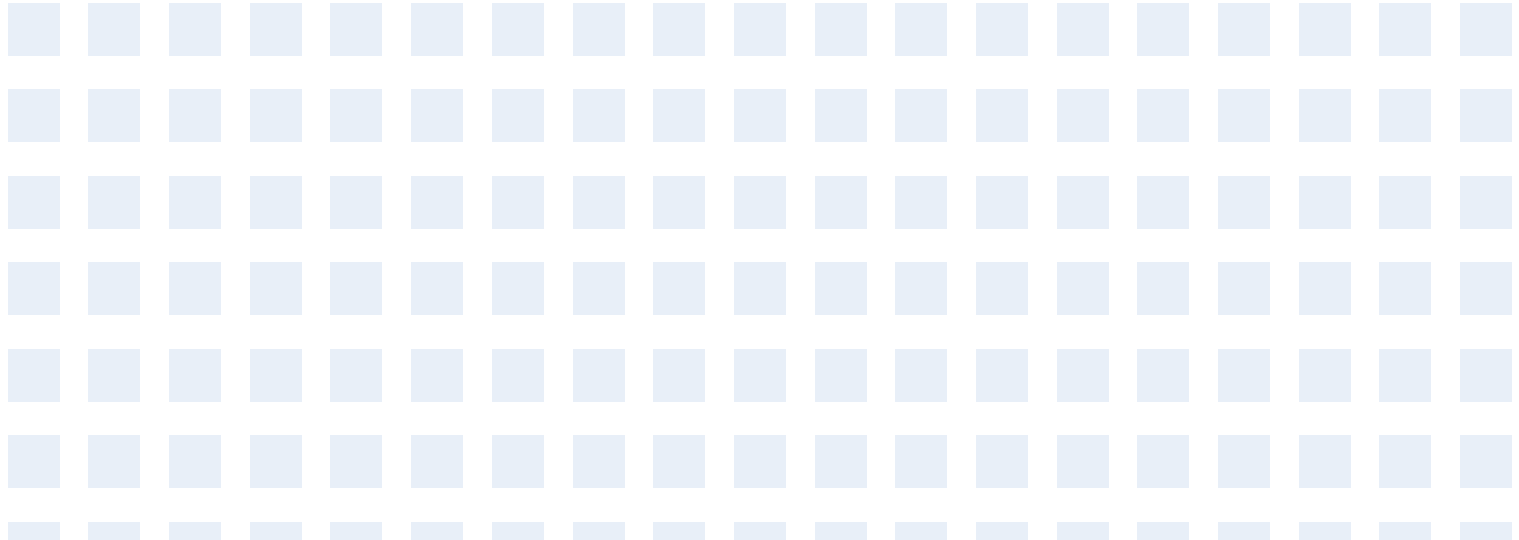

„ORIGINAL INSTRUCTIONS“

IMPORTANT NOTE:

Read this manual carefully before installing or operating your new heat pump.
Make sure to save this manual for future reference.

PL

Aby pobrać instrukcję dla tego produktu, wprowadź nazwę modelu pod tym linkiem:

**SK**

Pre stiahnutie manuálu k tomuto produktu zadajte modelové označenie do nasledujúceho odkazu:

**HR**

Za preuzimanje priručnika za ovaj proizvod unesite naziv modela na ovu vezu:

**SL**

Za prenos navodil za uporabo tega izdelka, vnesite ime modela na tej povezavi:

**IT**

Per scaricare il manuale di questo prodotto, inserisci il nome del modello a questo link:

**CZ**

Pro stažení manuálu k tomuto produktu zadejte modelové označení do následujícího odkazu:

**DE**

Um das Handbuch für dieses Produkt herunterzuladen, geben Sie bitte den Modellnamen für diesen Link ein:

**HU**

Termék kézikönyvének letöltéséhez írja be a modell megnevezését az alábbi linkre:

**UA**

Щоб завантажити посібник для цього продукту, введіть позначення моделі за таким посиланням:

**ES**

Para descargar el manual de este producto, ingrese la designación del modelo en el siguiente enlace:



FR

Pour télécharger le manuel de ce produit, entrez le nom du modèle sur ce lien ::

**RO**

Pentru a descărca manualul pentru acest produs, introduceți denumirea modelului în următorul link:

**NL**

Voer de modelaanduiding in de volgende koppeling in om de handleiding voor dit product te downloaden.



THANK YOU LETTER

Thank you for choosing Sinclair! Before using your new Sinclair product, please read this manual thoroughly to ensure that you know how to operate the features and functions that your new appliance offers in a safe way.

CONTENTS

THANK YOU LETTER	01
SAFETY PRECAUTIONS	02
1. PRODUCT INFORMATION	09
1.1 Content of packaging	09
1.2 How to transport / handling	09
1.3 Structure	10
1.4 Dimensions	12
1.5 Technical characteristic	13
2. INSTALLATION	15
2.1 Before installation	15
2.2 Fixing method	17
2.3 Hydraulic connection	18
2.4 Air duct connection	21
2.5 Electrical connection	22
2.6 Installation checklist	25
3. USE	26
3.1 Checklist before trail running	26
3.2 Initial start-up	26
3.3 About running	28
3.4 Control panel explanation	32
3.5 Use your appliance with SmartHome app	37
4. TROUBLE SHOOTING	39
4.1 Non-error tips	39
4.2 Something about the self-protection of the unit	40
4.3 When error happened	40
4.4 Error phenomenon shooting	40
4.5 Error code shooting table	41
5. MAINTENANCE	42
TRADEMARKS, COPYRIGHTS AND LEGAL STATEMENT	43
DISPOSAL AND RECYCLING	44
DATA PROTECTION NOTICE	45

SAFETY PRECAUTIONS

Read the instructions and warnings in this manual carefully, they contain important information regarding safe installation, use and maintenance. Incorrect installation due to ignoring instructions can cause serious damage or injury. The seriousness of potential damage or injuries is classified as either a **WARNING** or **CAUTION**.



DANGER

This represents a serious hazard that must be taken seriously to avoid death or injury to yourself and others.



WARNING

This represents a potentially hazardous situation. Warnings should be noted so that users can avoid situations that could result in damage to property and/or death or serious injury.



CAUTION

This symbol indicates owner/user should take care to avoid minor or moderate injury in a potentially harmful situation.



NOTICE

This symbol is to indicate that attention should be directed towards a specified procedure or maintain a specific condition.

Limit of application

This product is only suitable for household use, for the preparation of domestic hot water at 38-70°C . It must be connected to the household water supply and electricity supply. It is prohibited to use the equipment for other purposes like industrial production, or install it in any environment exposed to corrosion and combustion risks. The manufacturer is not responsible for damage to the equipment due to incorrect installation or improper use.

⚠ WARNING

- This appliance is not intended for use by persons with reduced physical, sensory or mental capabilities, or lack of experience and knowledge (including children), unless they're under the supervision or guidance of a guardian, and understand the dangers involved. Besides, they can not do the cleaning and maintenance without supervision.
- Children should be supervised to make sure they don't play with the appliance.
- Installation of the unit must be performed by a qualified person in accordance with local regulations in this manual. Improper installation may result in water leakage, electric shock or fire. Examples of a qualified person include: licensed plumbers, authorized electric company personnel, and authorized service personnel.
- This unit requires reliable earthing before usage, otherwise it might cause injury or death. The appliance shall be installed in accordance with national wiring regulations.



- Please have a qualified person perform the reliable earthing connection and the installation of the unit. If you can't make sure that your house power supply is earthed well, don't install the unit.
- Electric connection work should obey the instructions of the local power company, local electric utility and this manual.
- The maximum refrigerant charge amount is 0.15kg.

⚠ INSTALLATION WARNING

- Before wiring/pipes, confirm the safety of the installation area (walls, floors, etc.) without hidden dangers such as water, electricity, and gas.
- Place the appliance in an accessible place.
- Appliance shall be installed, operated and stored in a room with a floor area larger than 4m².
- Do not leave flammable materials in contact with or in the vicinity of the appliance.
- If the unit has an auxiliary electric heater, it must be installed at least 1 meter (40in) away from any combustible materials.
- Install the appliance in a frost-free room. The warranty does not cover destruction of the appliance through excess pressure caused by a blockage in the safety valve.
- If the appliance has to be installed in a room or location with an ambient temperature always above 35°C, this room must be ventilated.
- Product installation should be fixed firmly.

Wiring

- The wiring must be performed by professional technicians in accordance with national wiring regulations and the circuit diagram.
- The unit must be earthed effectively. A creepage breaker must be installed adjacent to the power supply.
- Before installation, check whether the user's power supply meets the electrical installation requirements of unit (including reliable grounding, leakage, and wire diameter electrical load, etc.). If the electrical installation requirements of the product are not met, the installation of the product is prohibited until the rectification is complete.
- The installation height of power supply should be over 1.8m, if there is any water spattered, separate the power supply from water.
- Never use the wire and fuse with wrong rated current, otherwise unit may break down and cause fire furthermore.
- In order to avoid a hazard due to inadvertent resetting of the thermal cut-out, this appliance must not be supplied through an external switching device, such as a timer, or connected to a circuit that is regularly switched on and off by the utility.

⚠️ INSTALLATION WARNING

- When installing multiple units in a centralized manner, please confirm the load balance of the three-phase power supply, and multiple units are prevented from being assembled into the same phase of the three-phase power supply.

Hydraulic connection

- The water inlet temperature of the equipment shall not be lower than 4°C, and the Maximum water temperature of the equipment can be set as 70°C.
- The Minimum water pressure of the water transmission pipeline system is 0.15MPa. A pressure reducer (not supplied) is needed when pressure is more than 7 bar (0.7 MPa) and it will be placed on the main supply.
- A discharge pipe connected to the pressure-relief device is to be installed in a continuously downward direction and in a frost-free environment. This pipe must be left open to the atmosphere, so that the water can drip from the discharge pipe of the pressure-relief device.
- A one-way valve must be installed on the water inlet side, which is available from accessories, see manual “accessories” part.
- Do not connect hot water piping directly to the copper piping. It must be equipped with a dielectric connection (not supplied with the appliance).
- Connect the safety unit to a drain pipe kept in the open air, in a frost-free environment, with a permanent downward gradient, to remove any expansion water from the heating process, or drainage water from the water-heater.
- The drainage pipe should be well insulated in order to prevent water inside pipe from freezing in cold weather.
- Arrange the drain pipe to ensure smooth draining. Improper drainage work may cause wetting of the building, furniture etc.

⚠️ OPERATION WARNING

- The earthing pole of socket must be grounded well, make sure that power supply socket and plug are dry enough and connected tightly.
- How to check the power supply socket and plug are qualified?
Turn on the power supply and keep the unit running for a half hour, then turn off the power supply and plug out, check whether the socket and plug are hot.

- Do not turn off the power supply.
- System will stop or restart heating automatically. A continuous power supply for water heating is necessary, except service and maintenance.
- Do not operate the unit with a wet hand. An electric shock may be caused.

- Water heated to over 50°C can cause immediate serious burns if delivered directly to the taps. Children, disabled persons and the aged are particularly at risk. We recommend installing a thermostatic mixer or water temperature limiting valve on the water delivery line. Feel water before bathing or showering.

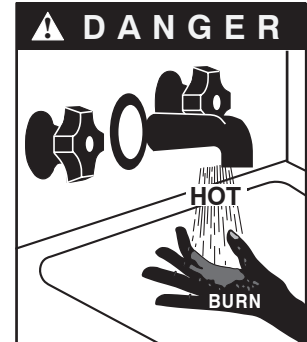

- Before cleaning, be sure to stop the operation and turn the breaker off or unplug the unit. Otherwise, an electric shock and injury may be caused.
- Ask qualified person for relocating, repairing and maintaining the unit instead of doing by yourself.
- Do not insert fingers, rods or other objects into the air inlet or outlet. When the fan is rotating at high speed, it will cause injury.
- Never use a flammable spray such as hair spray, lacquer paint near the unit. It may cause a fire.
- If the supply cord is damaged, it must be replaced by the manufacturer or its service agent or a similarly qualified person.
- Do not leave the packaging materials (staples, plastic bags, expanded polystyrene, etc.) within the reach of children -they can cause serious injury.
- After a long term use, check the unit base and fittings. If damaged, the unit may sink and result in injury.
- Do not touch the inner parts of the controller.
- Do not remove the front panel. Some parts inside are dangerous to touch, otherwise a machine malfunction may be caused. The pressure-relief device is to be operated regularly to remove lime deposits and to verify that it is not blocked.

OPERATION WARNING

- **DANGER:** The operation of the thermal cut-out indicates a possibly dangerous situation. Do not reset the thermal cut-out until the water heater has been serviced by a qualified person.
- **DANGER:** Failure to operate the relief valve easing gear at least once every six months may result in the water heater exploding. Continuous leakage of water from the valve may indicate a problem with the water heater.
- If the unit has not been used for a long period of time (2 weeks or more), hydrogen gas will be produced in the water piping system. Hydrogen gas is extremely flammable. To reduce the risk of injury under these conditions, it is recommended that open the hot water tap for several minutes at the kitchen sink before using any electrical appliance connected to the hot water system. When hydrogen is present, there will probably be an unusual sound such as air escaping through the pipe as the water begins to flow. There should be no smoking or open flame near the tap at the time it is open.

OPERATION CAUTION

- Do not remove, cover or deface any permanent instructions, labels, or the data label from either the outside of the unit or inside of unit panels.
- It is normal that water drips from the overpressure safety device or from the EN 1487 safety unit when the appliance is heating. For this reason one must install a drain, open to the air, with a continuously downwards sloping pipe, in an area not subject to subzero temperatures. A condensate drain should also be connected to the same pipe with a special coupling.
- Make sure you drain the appliance when it is out of service in an area subject to subzero temperatures.
- Regarding how the water heater can be drained, please refer to the below paragraphs of the manual.
- SMART mode is not recommended when water consumption is low or irregular.



BATTERY WARNING



WARNING: Contains button or coin cell battery.

WARNING: The battery is hazardous and **KEEP OUT OF REACH OF CHILDREN** (Whether the battery is new or used).

- If the battery compartment (if applicable) does not close securely, stop using the product and keep it away from children.
- For appliances which contain coin or lithium batteries:



BATTERY WARNING

KEEP OUT OF REACH OF CHILDREN.

Swallowing can lead to chemical burns, perforation of soft tissue, and death. Severe burns can occur within 2 hours of ingestion. Seek medical attention immediately.



- For appliances which contain button or non-lithium batteries.
 - The battery can cause serious injuries if it is swallowed or placed inside any part of the body.
 - If you think batteries might have been swallowed or placed inside any part of the body, seek immediate medical attention.

BATTERY PERFORMANCE

- For more durable batteries, it is recommended to turn off the power when not in use for a period of time.

! BATTERY DISPOSAL

- Do not dispose of batteries as unsorted municipal waste. Refer to local laws for proper disposal of batteries.
- Batteries may have a chemical symbol at the bottom of the disposal icon. This chemical symbol means that the battery contains a heavy metal that exceeds a certain concentration. An example is Pb: Lead (>0.004%).
- Appliances and used batteries must be treated in a specialized facility for reuse, recycling and recovery. By ensuring correct disposal, you will help avoid possible negative consequences for the environment and human health.
- Dispose of used button/coin batteries immediately.
- Place sticky tape around both sides of the battery and dispose of it immediately in an outside bin, out of reach of children, or recycle safely.



1. PRODUCT INFORMATION

All the pictures in this manual are for explanation purpose only. They may be slightly different from the heat pump water heater you purchased (depending on the model). Please refer to the real sample instead of the picture of this manual.

1.1 Content of packaging

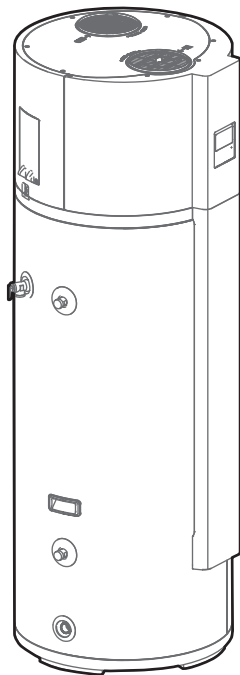

main unit



One way valve (Page 19)



Air duct connector (Page 21)



Filter (Page 21)



Safety & User's manual



condensate drain pipe (Page 20)

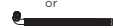

Fixing strip (Page 17)

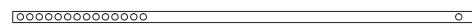

1.2 How to transport / handling

⚠ CAUTION

- Please carry the unit according to the factory state, do not disassemble it by yourself.
- This unit is heavy, it needs to be carried by two people or more, otherwise it might cause injury to people and damage to the unit.
- Keep away your fingers from the vanes.
- In order to avoid scratch or deformation of the unit surface, protect the surface from contacting with hard objects.
- While moving, please use the handles on both sides of the unit.

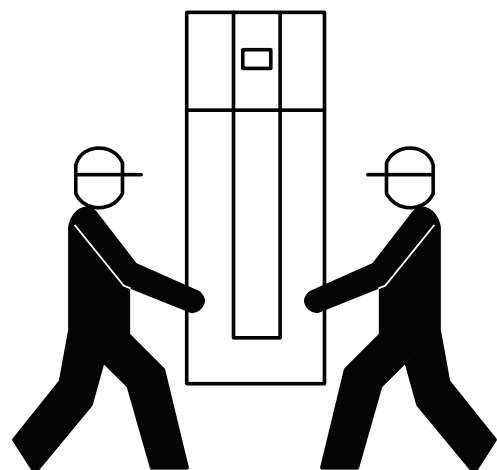

fig 2-1

1.3 Structure

When ordering spare parts, please provide:

1) Model, serial and product number; 2) Parts name

SWH-190P

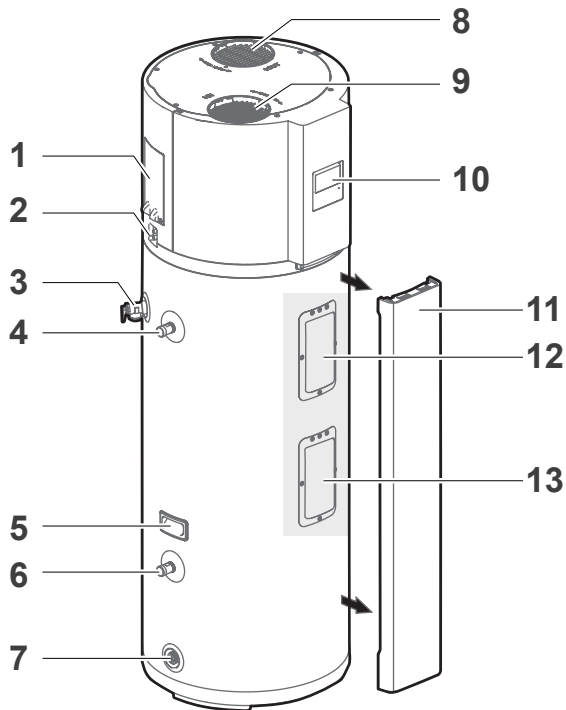

1. Junction box
2. condensate drain
3. PTR valve
4. water outlet
5. handle
6. water inlet
7. drain outlet
8. air outlet
9. air inlet
10. display
11. front decorative board
- 12(18). the unpper cover
- 13(19). the lower cover
14. magnesium rod
15. electronic anode
16. TCO
17. electrical heater
20. temperature sensor cover

SWH-300P

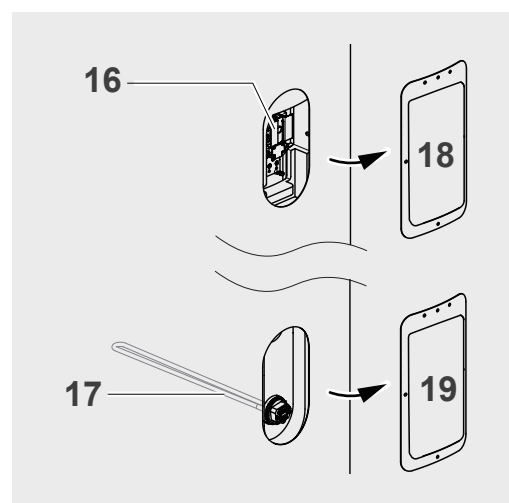
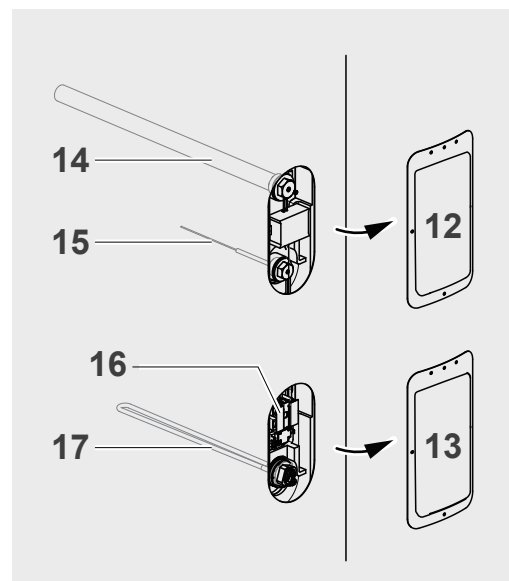
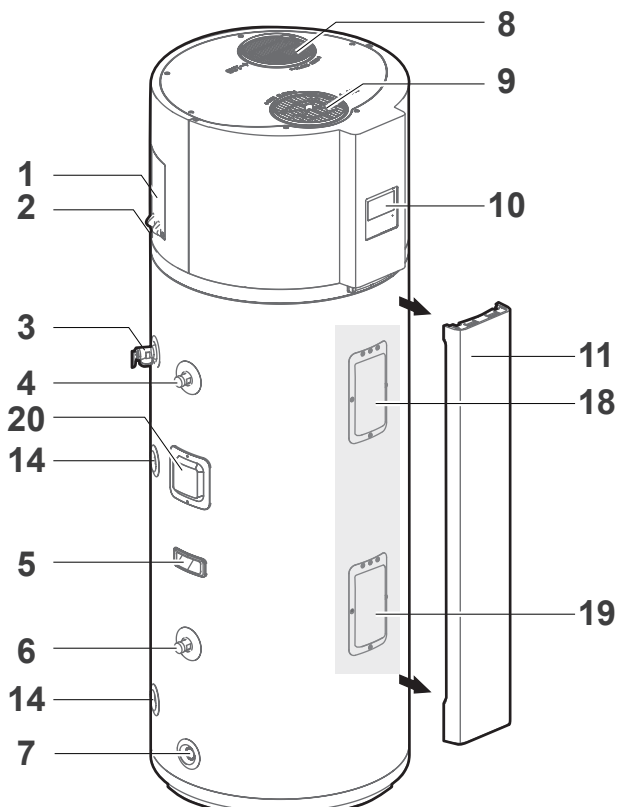

The head's structure

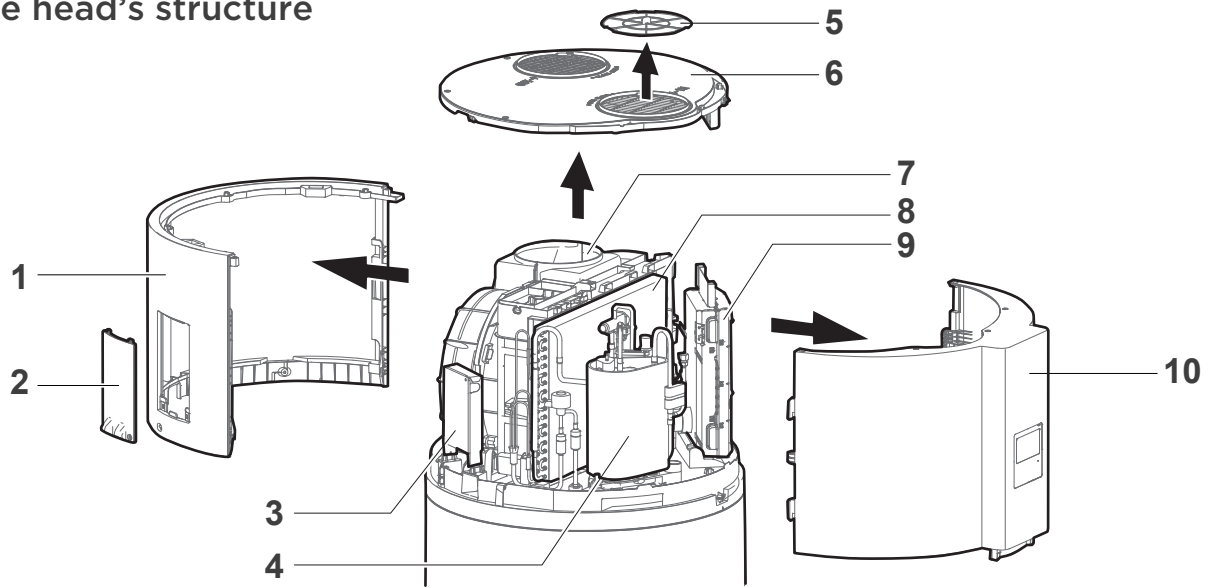

- | | | | |
|----|--------------------|-----|------------------------|
| 1. | rear cover | 6. | top plate |
| 2. | junction box cover | 7. | fan assembly |
| 3. | junction box | 8. | evaporator |
| 4. | compressor | 9. | electronic control box |
| 5. | filter | 10. | front cover |

⚠ CAUTION

For your safety DO NOT attempt repair of electrical wiring, heating elements, heat pump or electronic controls. Refer repairs to qualified service personnel.

⚠ WARNING

FLAMMABLE CONTENTS UNDER PRESSURE.

The compressor is not a serviceable part. The compressor wiring terminals may be allowing pressurized refrigerant and oil to escape, ignite and cause serious bodily injury, severe burns or death.

1.4 Dimensions

connector	spec.
hot water outlet	R3/4"
cold water inlet	R3/4"
PTR valve	RC3/4"
drain pipe	NPT3/4"

SWH-190P

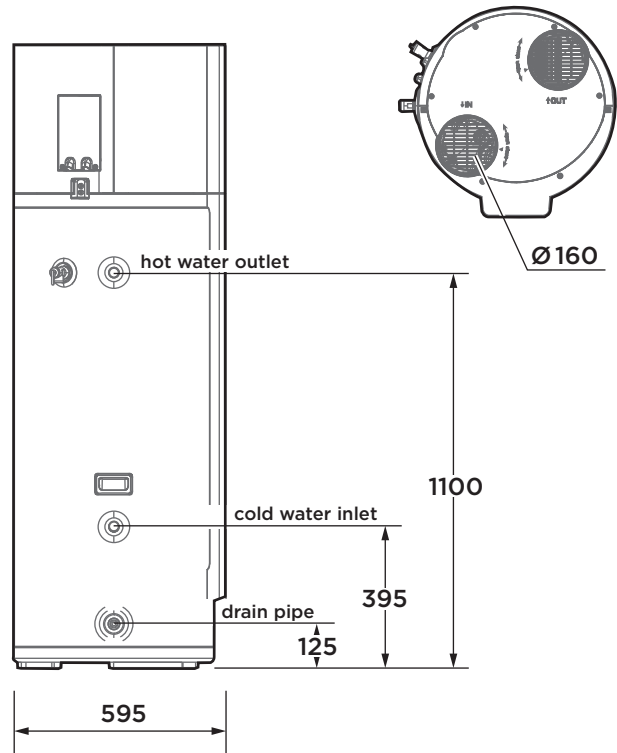
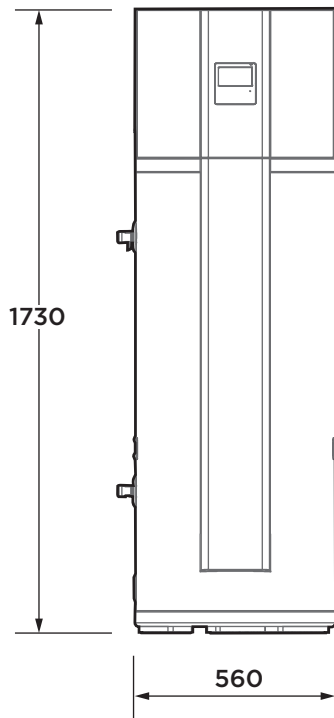

SWH-300P

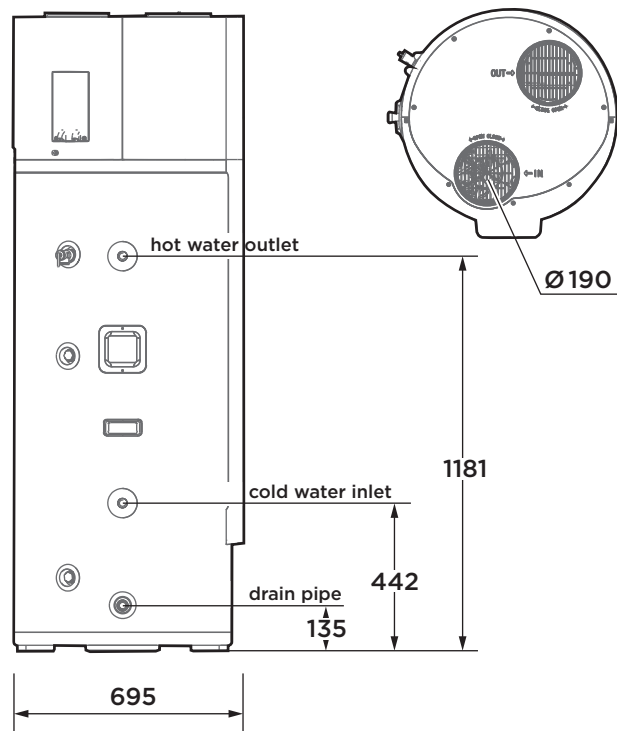
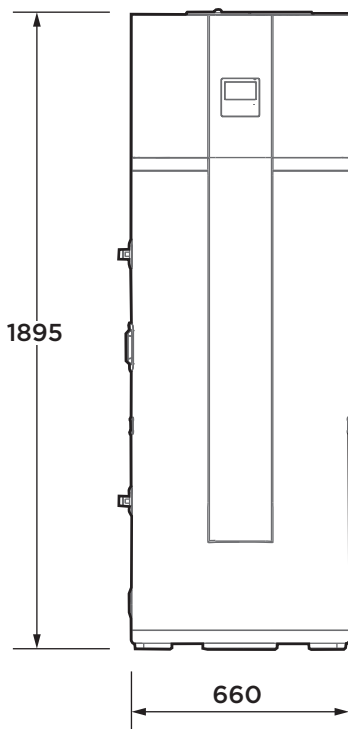

1.5 Technical characteristic

Model	SWH-190P	SWH-300P	
UNIT GENERAL INFO			
Water tank cap.	185 L	275L	
Net weight	91 kg	123 kg	
Dimension	560×595×1730 mm	660×695×1895 mm	
Refrigerant	R290 (0.15 kg)		
Running air inlet temp	-7~43 °C (E-heater: -20~46 °C)		
Max. hot water temp (heat pump)	65 °C		
Max. hot water temp (e-heater)	70 °C		
Water heating cap. ①	heat pump	1430 W	1500 W
	E-heater:	1640 W	1640 W
Air side exchanger	Hydrophilic aluminum fin, inner groove copper tube		
Water side exchanger	Microchannel heat exchanger		
Fan type	Centrifugal		
Ari volume flow rate	350 m ³ /h	450 m ³ /h	
Max. sound power (EN12102)	56 dB	54 dB	
PERFORMANCE (EN 16147) ②			
Load profile	L	XL	
Water heating energy efficiency class	A+	A+	
Water heating energy efficiency / η	131.10 %	132 %	
COP _{DHW}	3.146	3.25	
Maximum volume of mixed water at 40 °C-V ₄₀	245 L	350 L	
Reference hot water temperature- θ_{wh}	53 °C	52 °C	
Rated heat output	11.694 kW·h	19.07 kW·h	
Heating up time-t _h	07:32 hh: mm	08:58 hh: mm	
Annual electricity consumption	780.8 kW·h	1267 kW·h	
Stand-by power input(P _{es})	27 W	19.1 W	
TANK			
Material	Steel tank with vitreous enamel coating		
Cathodic protection	Magnesium rode anode		
Insulation thickness	42 mm Polyurethane	46mm Polyurethane	
Max. inlet water pressure	0.7 MPa		
Max. operating pressure (safety valve)	0.85 MPa		
ELECTRICAL DATA			
power supply spec.	220-240V ~ 50Hz		
E-heater power	1640 W		
Motor power	30 W	30 W	
Max. heat pump power input	600 W	710 W	
Max. power input	2240 W	2350 W	
Max. current input	10.5 A	11 A	
Protection	Over-load Protector, Temp Controller & Protector, Electric Protector, etc.		
Fusible link type	T5A 250VAC/T16A 250VAC		
Insulation protection rating	IP21		

Model	SWH-190P	SWH-300P
SOLAR COIL		
Material		/
Surface		/
Max. pressure		/

NOTE:

① The test conditions: outdoor temp. 15/12 °C(DB/WB), inlet water temp = 15°C, outlet water temp = 45°C.

② Data according to EN 16147: 2017 standard for AVERAGE climate (unit in ECO mode, Hot water setpoint = 53 °C(185L)/ 52 °C (275L) ; Inlet water = 10°C ; Inlet air temp = 7°C DB / 6°C WB) * according to European regulation 812/2013.

2. INSTALLATION

2.1 Before installation

2.1.2 Location requirements

- **IMPORTANT!** The unit must be installed indoor , it is not allowed to be installed outdoor without shelter. Avoid installation in direct sunlight.

⚠ WARNING

- In case of rain entering to internal components of the unit, the component might be damaged or causing physical danger.
- In terms of the unit connect with duct reaching to outdoor, a reliable water resistant measure must be conduct on the duct, to prevent water from dropping into internal of the unit.
- The unit needs to be securely fixed, otherwise it may cause heavy consequences.

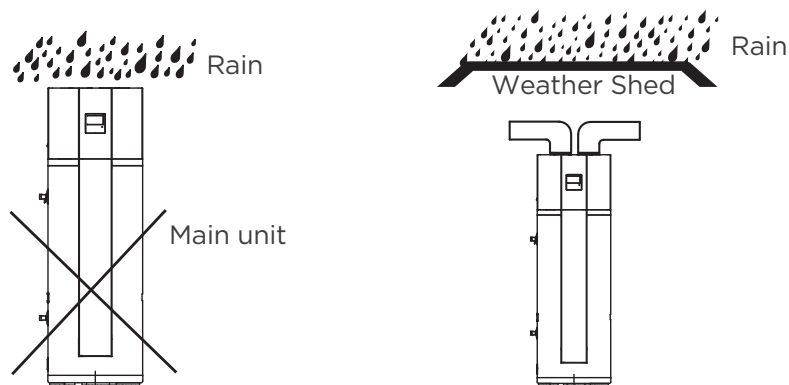

- Enough space for installation and maintenance shall be preserved.
- The ground surface should be flat, and inclined no more than 2°.
- The ground must able to bear the weight of the unit and suitable for installing the unit without increasing noise or vibration.
- To smoothly drain condensate water from the unit, please install the unit at a horizontal floor. Otherwise, ensure the drain vent is at the lowest level.
- The air inlet and outlet should be free from obstacles and strong wind.
- The operation noise and air flow expelled shall not affect neighbors.
- No obstacle around the unit.
- No flammable gas is leaked nearby.
- It is convenient for piping and wiring.
- The ambient air temperature must also be considered when installing this unit, in heat pump mode the air inlet temperature must be above -7 °C and below 43°C. If the inlet air temperature falls outside these upper and lower limits, the electrical elements will be activated to meet the hot water demand and the heat pump does not operate.

⚠ CAUTION

- If the unit is installed on the balcony, the water full weight should not exceed the load-bearing limit of the balcony.
- If the unit has to be installed on a metal part of building, make sure the well electric insulation which should meet the relevant local electric standard.
- The unit installed in indoor space might cause indoor temperature decrease and noise. Please take preventive measures for this.
- The unit should be located in an area not subject to freezing temperatures. The unit located in unconditioned spaces (i.e., garages, basements, etc.) may require the water piping, condensate piping, and drain piping to be insulated to shelter against freezing.
- Installing the unit in any of the following places may lead to malfunction (If it is inevitable, consult the supplier).
 - ☒ The site contains mineral oils such as lubricant of cutting machines.
 - ☒ Seaside where the air contains much salt.
 - ☒ Hot spring area where corrosive gases exist, e.g., sulfide gas.
 - ☒ Factories where the power voltage fluctuates seriously.
 - ☒ Inside a car or cabin.
 - ☒ The place with direct sunlight and other heat supplies. If there's no way to avoid these, please install a covering.
 - ☒ Place like kitchen where oil permeates.
 - ☒ Place where strong electromagnetic waves exist.
 - ☒ Place where flammable gases or materials exist.
 - ☒ Place where acid or alkali gases evaporate.
 - ☒ Other special environments.

2.1.3 Maintenance space requirements

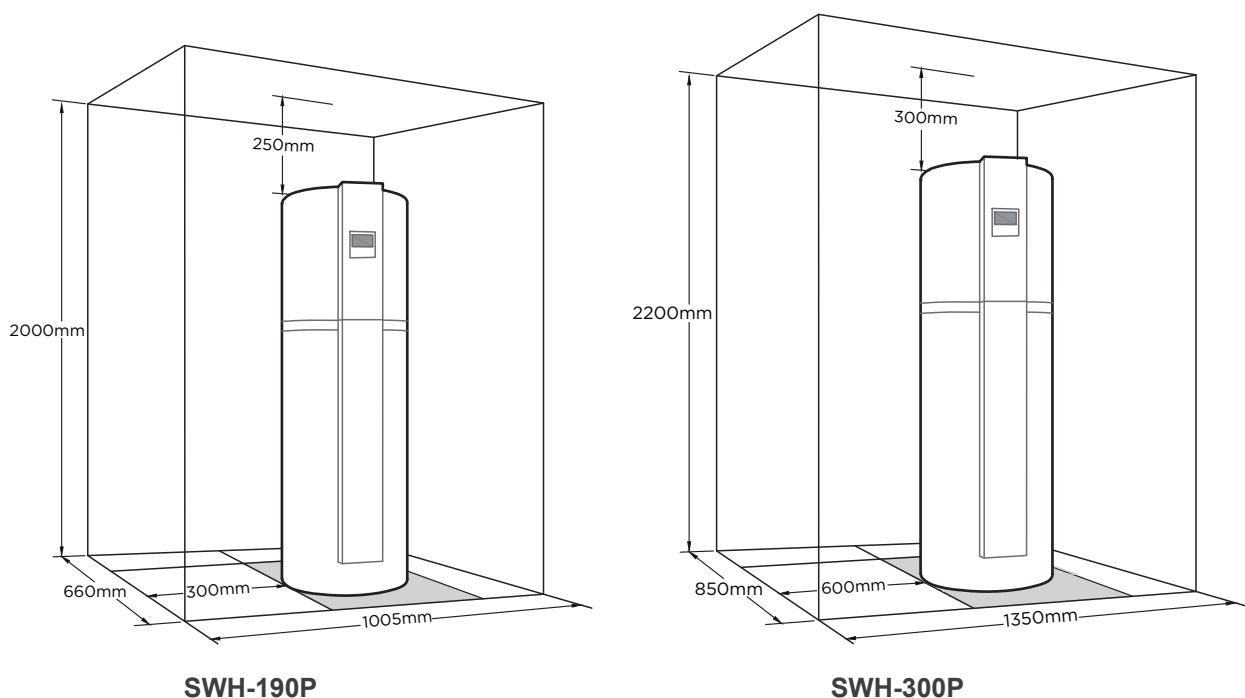

2.2 Fixing method

⚠ CAUTION

- In order to prevent accidental fall, please fasten the water heater to the walls.

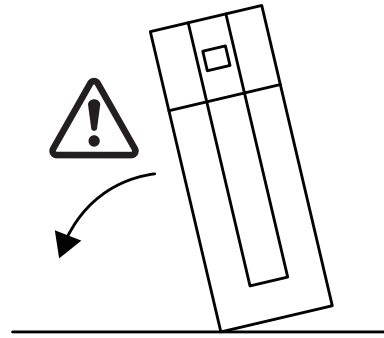

Water heater fixing steps are as follows:

- 1) Take off the front decorative board.
- 2) Install the expansion bolts(not provided) in the wall according to the drawing.
- 3) Fix the end with less holes for mounting the fixing strip on the expansion bolt.
- 4) Tighten the fixing strip and fix the other end to the second expansion bolt through appropriate hole.
- 5) Check whether the water tank is securely fixed. If there's extra fixing strip, please cut it off.
- 6) Put back the decorative board.

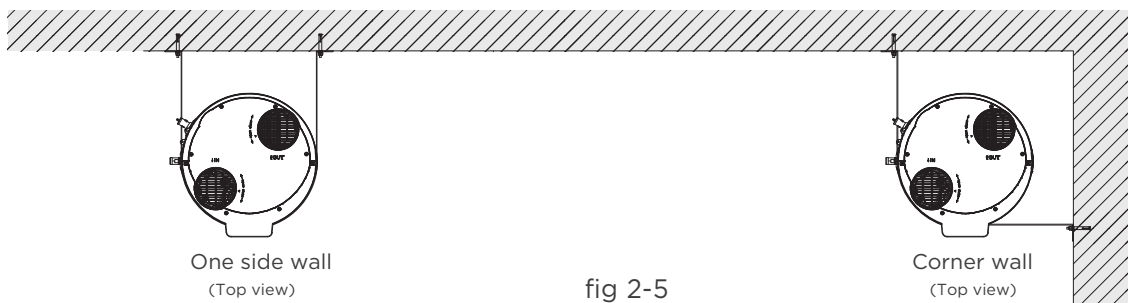
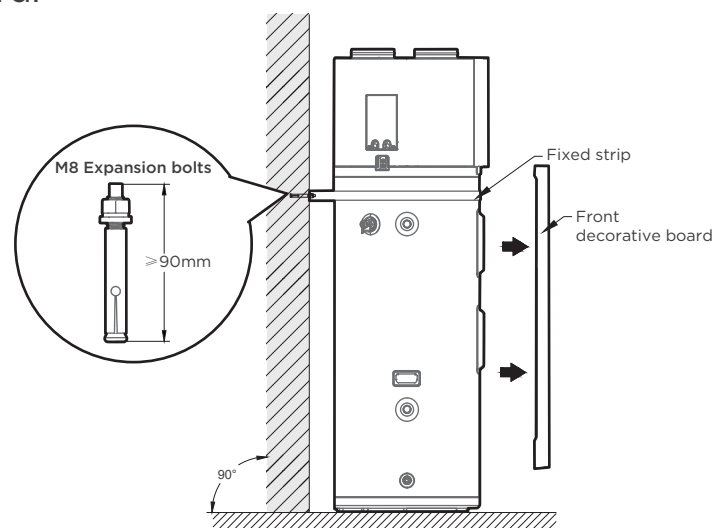

fig 2-5

⚠ CAUTION

- The appearance and installation orientation of the unit shown above are for reference only and can be adjusted according to the actual installation.
- The position of the fixed strip can be adjusted according to the actual situation, make sure the unit is safely and securely fixed.
- The expansion bolt requirement must match the weight of the product (loaded with water).

2.3 Hydraulic connection

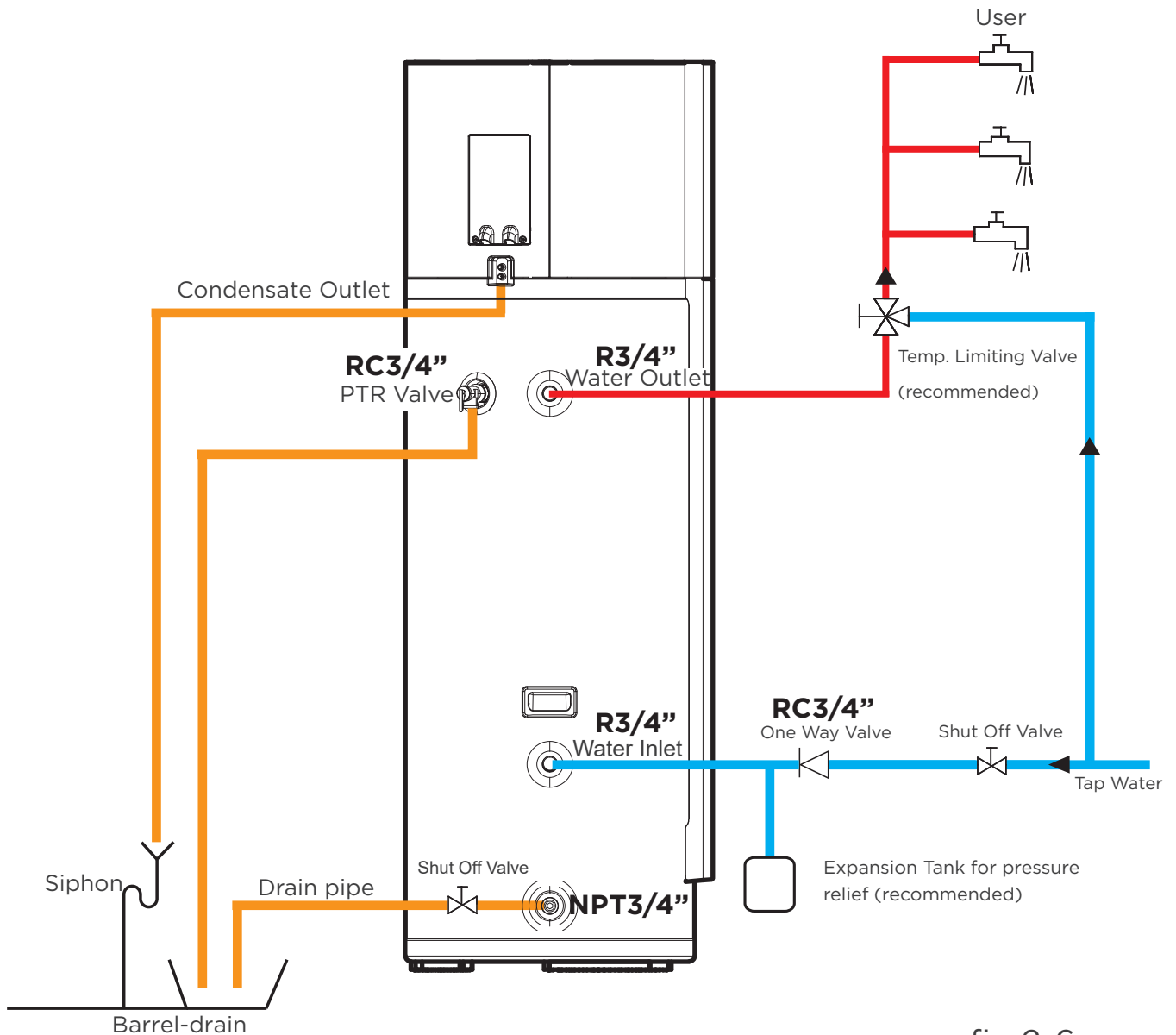

fig 2-6

● NOTE

- Connect water pipes as the above figure.
- Water temperature limiting valve is recommended for mixing the inlet cold water with outlet hot water to prevent burns caused by hot water.
- Check before connection, make sure the pipe is clean and free of any foreign matter.

1) Cold water connection

The spec of the water inlet thread is DN20(external thread). Use well-insulated pipes to connect the water inlet to the house's water supply. Install the one way valve (thread RC3/4") provided in accessories to the inlet pipe to prevent water from flowing backwards.

⚠ CAUTION

- In any type of installation there should be a stop valve (not provided) on the cold water inlet.
- We recommend a supply pressure of 3~4 bar (0.3 to 0.4 MPa). If the inlet water pressure is less than 0.15MPa, a pump should be installed at the water inlet. If the main water supply pressure is higher than bar (0.7MPa), a reducing valve should be used at the water inlet pipe.
- For regions with a lot of scale ($T_h > 20^\circ\text{f}$), we recommend to treat the water. The hardness after softener has to be higher than 15°f . The use of a softener does not influence the warranty if the softener is approved for the country of installation and set to the rules of art, with regular checking and maintenance.
- Local criteria of drinking water quality have to be respected.

2) Hot water connection

The spec of the water outlet thread is DN20(external thread). Use well-insulated pipes to connect the water outlet to the water terminal in the house

⚠ CAUTION

Water temperature over 50°C can cause severe burns instantly or death from scalds. We recommend installing a thermostatic mixer valve on the water delivery line.

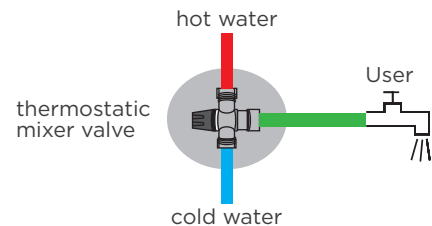

3) Drainage connection

The spec of the Drainage is NPT3/4. The unit comes with a plug. Replace the plug with a shut off valve and connect the unit to the drain pipe open to air.

4) Condensate evacuation

Connect the two condensate drain pipes in the fitting to the condensate outlet, as shown in fig 2-7.

Depending on the degree of humidity in the air you can get up to 0.25L/h of condensation. The condensate drain line should not be connected to the house sewer directly. Instead, use a siphon which contains water to prevent the unit from corrosive gases.

5) Installation of the pipe for PTR valve

The spec of the safety valve connecting thread is RC3/4”(internal thread) and it was installed already.

The overflow of the safety valve has to be connected to a drainpipe that is open to the air, and connect to the used water evacuation through a siphon. Installation has to be in a frost-free environment. The safety valve has to be operated regularly (every half year) to check the working condition.

⚠ CAUTION

- In case of installing it at a place where outside temperature below freezing point, insulation must be provided for all hydraulic components.
- The handle of PTR valve should be pulled out once per half a year to make sure that there is no jam of the valve. Please beware of burn, beware of the hot water from the valve.
- The drainage pipe should be well insulated in order to prevent water inside pipe from freezing in cold weather.

⚠ WARNING



Do not block off the safety valve drainage pipe. It will cause explosion and injury, if do not comply with the above instruction.

Tips:

Condensate may be leaked from unit if drainage pipe is blocked or unit operates in high humidity environment, a drainage pan is recommended as shown as figure.

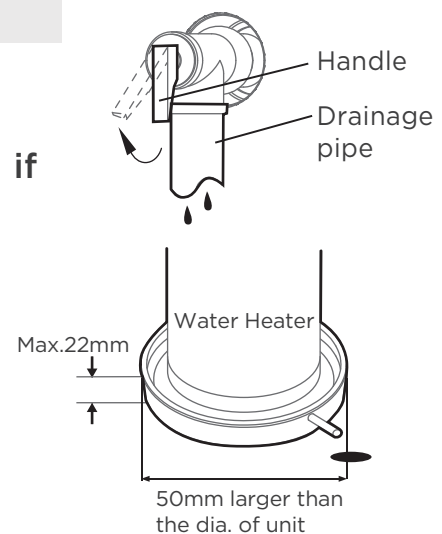

After water system piping work, turn on the cold water inlet valve and hot water outlet valve and start effusing the tank. Check pipeline to make sure there is not any leakage. When water flow smoothly out from water outlet pipe (tap water outlet), the tank is full, turn off all the outlet valves.

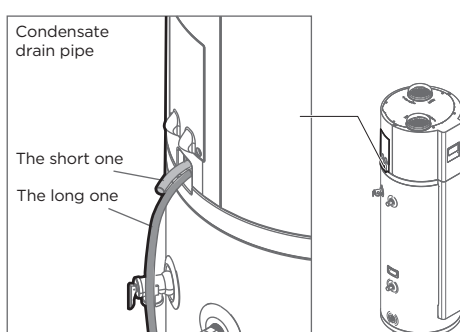
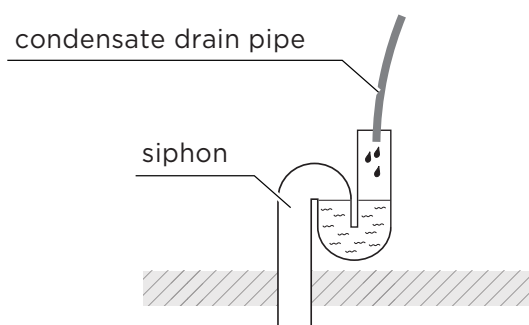

fig 2-7



2.4 Air duct connection

It is strongly recommended to use rigid ducts meeting the following requirements:

SWH-190P: Ø160mm, total length ≤ 5m;
 SWH-300P: Ø190mm, total length ≤ 10m,* 1 bend = 1m duct

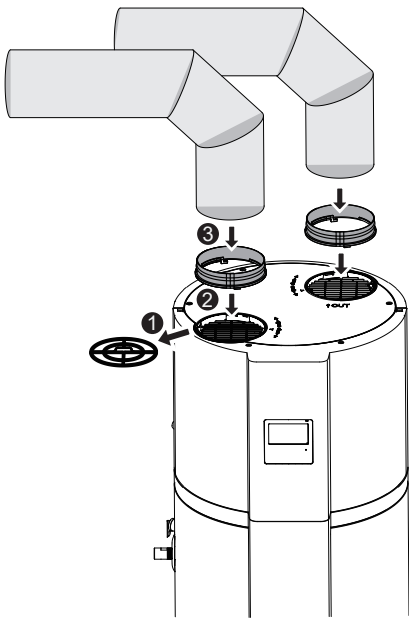

NOTE

- The resistance of duct will decrease air-flow-rate, which will lead to capacity of unit decreased.
- For unit air outlet with duct, when unit operating, condensate will be generated around outside of duct. Please pay attention to the drainage work, we suggest to wrap the thermal insulated layer around outside of the duct.
- Filter should be installed at the unit air inlet. In terms of the unit with duct, filter in there must be put on the position of duct inlet.

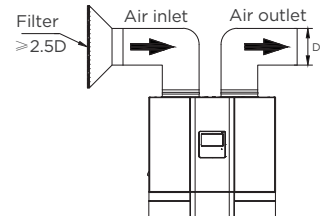

Owner should install the filter by self; and the mesh size is about 1.2mm.

2.4 .1 Typical installation

Different ways of air ducts connection

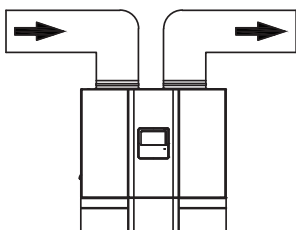

1. Air inlet and outlet with ducts.

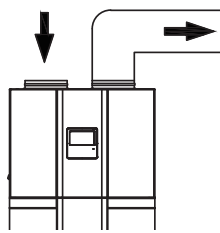

2. Air outlet connects to duct, air inlet without ducts.

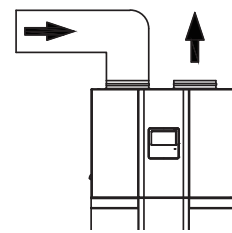

3. Air inlet connects to duct, air outlet without ducts.

Different directions of air ducts connection

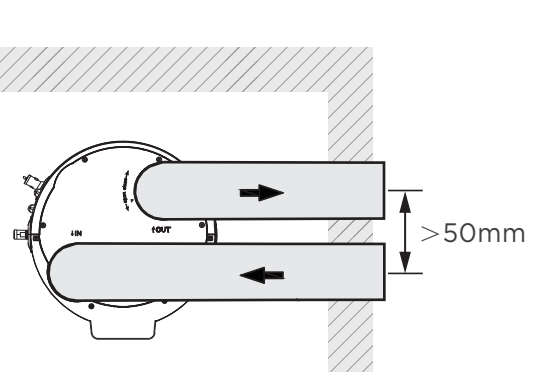
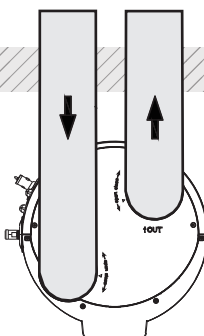
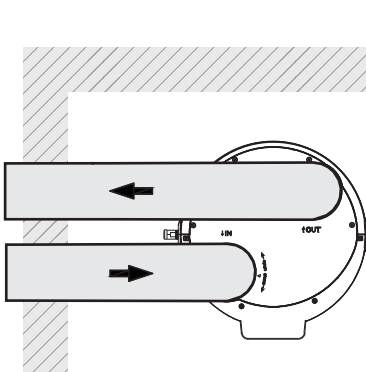

2.5 Electrical Connection

⚠ CAUTION

- The power supply should be an independent circuit with rated voltage.
- Power supply circuit should be earthed effectively.
- The wiring must be performed by professional technicians in accordance with national wiring regulations and this circuit diagram.

CODE	NAME
CT1	CURRENT TRANSFORMER
CT2	ZERO SEQUENCE CURRENT TRANSFORMER
T3	EVAPORATOR TEMPERATURE SENSOR
T4	AMBIENT TEMPERATURE SENSOR
T5U	TANK TEMPERATURE SENSOR (UPPER)
T5L	TANK TEMPERATURE SENSOR (LOWER)
TP	DISCHARGE TEMPERATURE SENSOR
TH	SUCTION TEMPERATURE SENSOR
EEV	ELECTRIC EXPANSIVE VALUE
XT1-3	MID TERMINAL BASE
T5M	SOLAR TEMPERATURE SENSOR
E-Mg	ELECTRONIC MAGNESIUM ROD

SMART GRID		
Operating behavior	EVU/PV	SG
Normal operation(Default)	Invalid	Valid
Increased operation output	Valid	Invalid
Decreased operation output	Invalid	Invalid

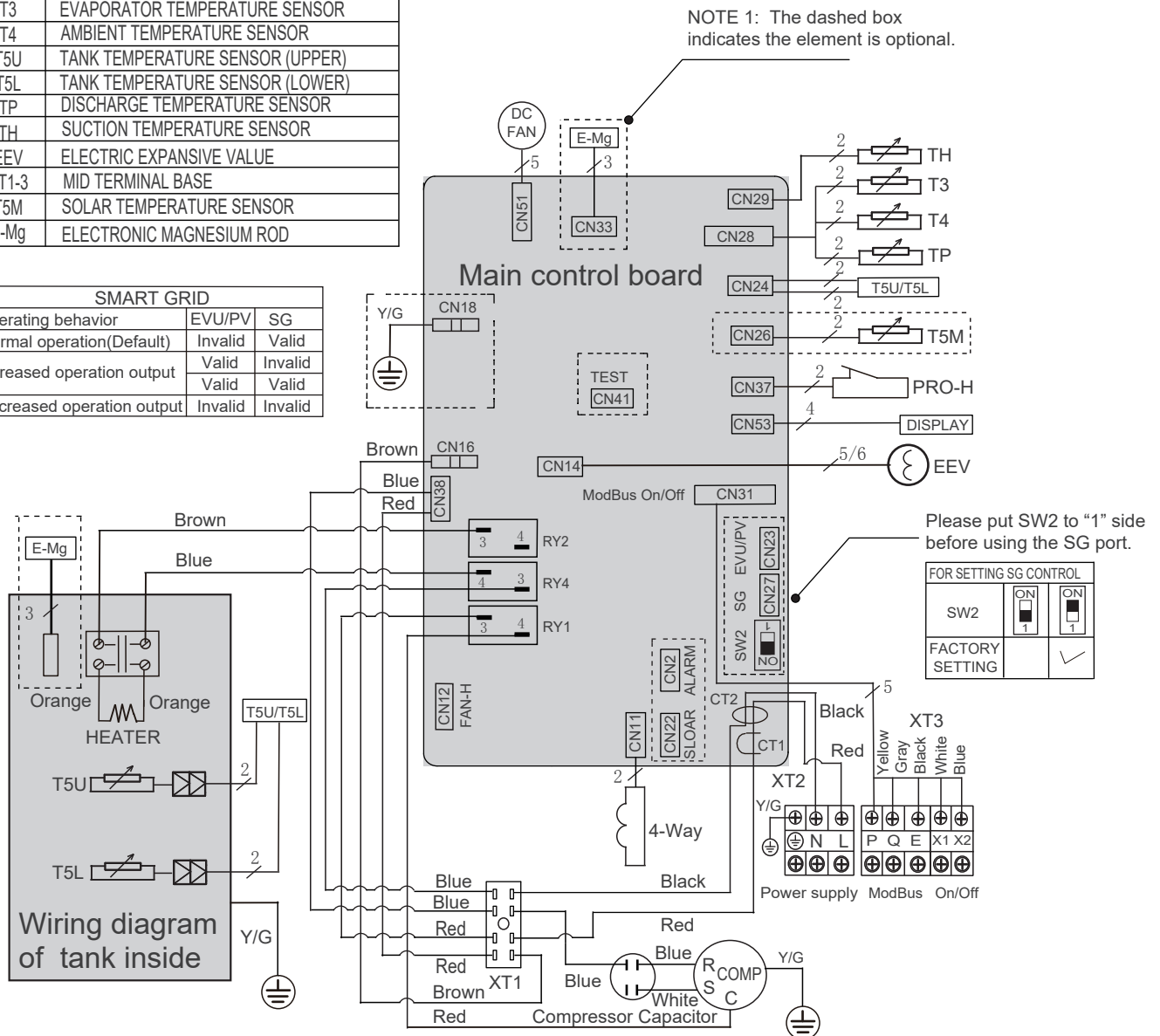

NOTE 2: Wiring comes out from tank, must connect with the corresponding component.

NOTE 3: P-RS485A; Q-RS485B; E-RS485 GND; X1-Remote ON/OFF Signal; X2-Remote ON/OFF GND

⚠ CAUTION

- An all - pole disconnection device which has at least 3mm separation distance in all pole and a residual current device (RCD)with the rating of above 10mA(30 mA is recommended) shall be incorporated in the fixed wiring according to the national rule.
- Set the electric leakage protector according to the relevant electric technical standards of the state.
- The power cord and the signal cord shall be laid out neatly and properly without mutual interference or contacting the connection pipe or valve.
- After wire connection, check it again and make sure the correctness before power on.

2.5.1 Specifications of Power Supply

The recommended power cord model is **H05RN-F**. You can choose the power cord according to the following table, and it should comply with local electric standard.

Power Supply	220-240V
Min. Diameter of Power Supply Cord	1.5 mm ²
Earth Cord	1.5 mm ²
Manual Switch	30/25 (A)
Creepage Breaker	30mA ≤ 0.1 sec

2.5.2 Power cord connection

The steps for connecting power cables are as follows:

step1

Remove both screws and take off the junction cover; Remove both screws and take off the metal protective cover;

step2

Route the power cable through the bottom cable hole; Connect the power cable to ⊕, N, L and fix the cable with the below tie; The power cable should route through the left hole reserved on the junction box cover. Put the metal protective cover and junction box cover back.

step 1

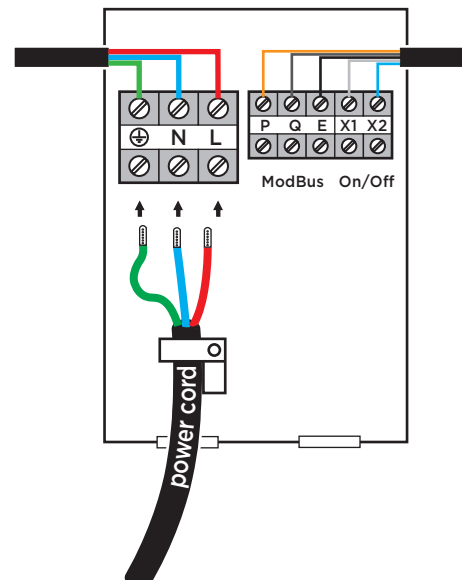
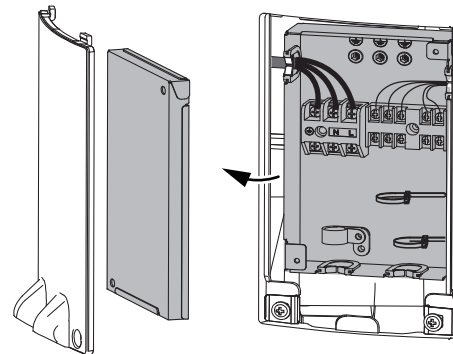

⚠ WARNING

- Ensure the ground wire has the longest length, to prevent it from being pulled.

⚠ CAUTION

- When wiring the power supply, please add additional insulation sheath at the place without rubber insulation layer.

⚠ WARNING

- The unit must be installed with a Creepage Breaker near the power supply and must be effectively earthed.

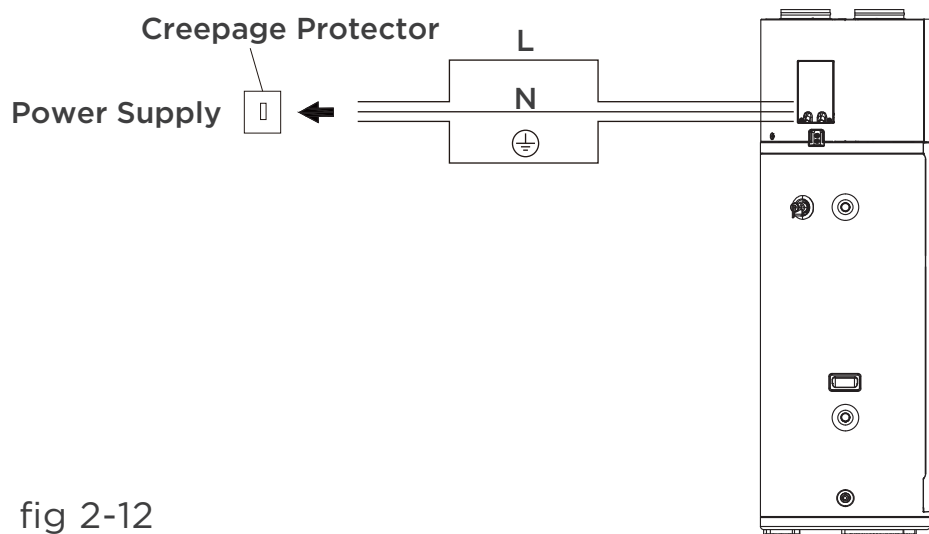

fig 2-12

2.6 Installation checklist

2.6.1 Location & space

- The floor must be able to bear the weight of the unit when filled with water (more than 276kg).
- Located indoor such as a basement or garage and in a vertical position. Protected from freezing temperature.
- Allow sufficient space for maintenance and service.
- Allow sufficient air for the heat pump to operate. The water heater heat pump must have unrestricted air flow.
- The unit cannot be placed into any type of closet or small enclosure.
- The site location must be free from any corrosive elements in the atmosphere such as sulfur, fluorine, and chlorine. These elements are found in aerosol sprays, detergents, bleaches, cleaning solvents, air fresheners, paint, and varnish removers, refrigerants, and many other commercial and household products. In addition excessive dust and lint may affect the operation of the unit and require regular cleaning.
- The inlet air temperature must be above -7°C and below 43°C . If the inlet air temperature goes out of this limits the electrical elements will be activated to meet the hot water demand and the heat pump will not operate.

2.6.2 Hydraulic connection

- PTR valve (Temperature and pressure relief valve) has to be properly installed with a discharge pipe going to an adequate drain and sheltered from freezing.
- All pipes must be properly installed and with no water leakage.
- Water temperature limit valve or mixer tap (recommended) has been installed.
- Condensate drain lines must be installed with an easy access.
- The condensate drain outlet must be at the lowest position of the unit.
- A siphon has been connected to the condensate drain pipings.

2.6.3 Electrical connections

- The water heater requires 220-240 VAC for proper operation.
- Wiring size and connections comply with all local applicable codes and the requirements of this manual.
- Water heater and electrical supply must be properly earthed.
- Proper overload fuse or circuit breaker protection must be installed.

2.6.4 Post Installation review

- Make sure the users understand how to use the User Interface Module to set the different modes and access the different functions.
- Make sure the users understand the importance of routine inspection/maintenance of the condensate drain pan and lines. This is to help prevent any possible drain line blockage resulting in the condensate drain pan overflowing.
- IMPORTANT:** Water coming from the plastic shroud is an indicator that both condensation drain lines may be blocked. Immediate action is required.
- To maintain optimal operation check, remove and clean the air filter.

3. USE

3.1 Checklist before trial running

- Correct installation of the system.
- Correct connection of water/air piping and wiring.
- Smooth condensate drainage and proper installation of all hydraulics.
- Correct power supply.
- No air in the water pipeline and all valves opened.
- Effective installation of electrical protections (residual-current device, RCD).
- Sufficient inlet water pressure (between 0.15MPa and 0.7MPa).
- Unit completely filled with water.

⚠ CAUTION

If the unit has been placed in horizontal position, keep it in a vertical position for at least 60 min before start-up.

3.2 Initial start up

Follow the steps below to start up the unit.

1) Filling the tank with water before operation

Please ensure that the tank is full of water before turning on the power. Water filled method is as follows:

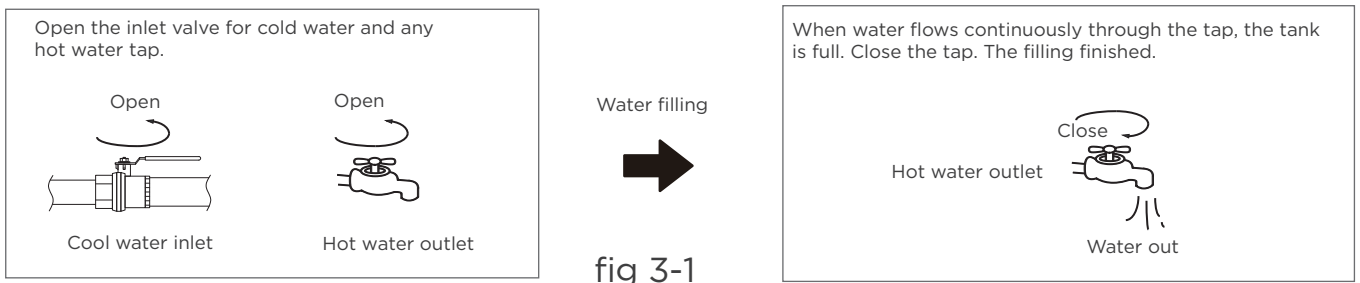

The water tank should be filled when the unit is used again after emptying.

⚠ CAUTION

- The water tank must be filled when using the unit again after emptying it.
- Ensure that there is no water leakage in the pipe before starting up.
- Operation without water in water tank may result in the damage of E-Heater. Manufacturer is not liable for any damages caused by this issue.

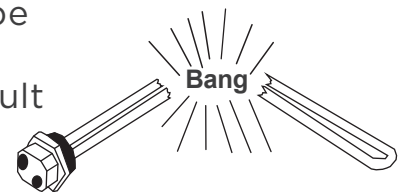

CAUTION:

If the unit needs cleaning, moving, stop using, etc., the tank should be emptied. Emptying Method is as follows:

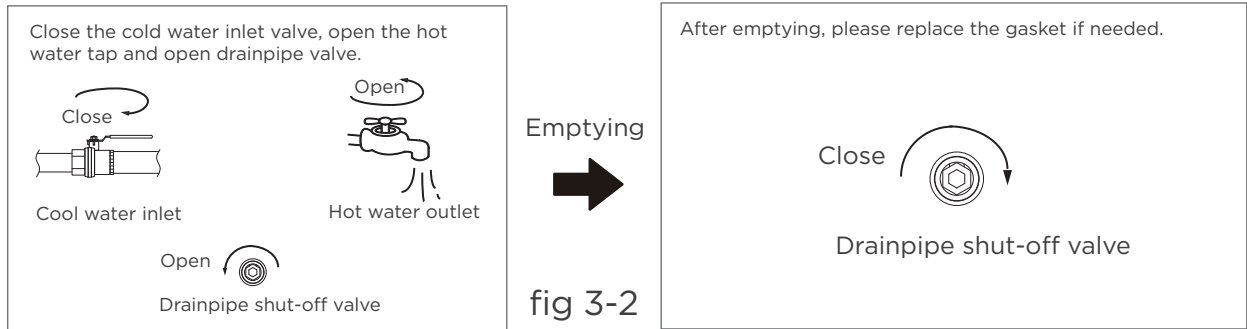

CAUTION: The water will flow through drainpipe shut-off valve! It could be hot! Pipe it into the sewage system!

2) Start up

After powered on, the display will light up.

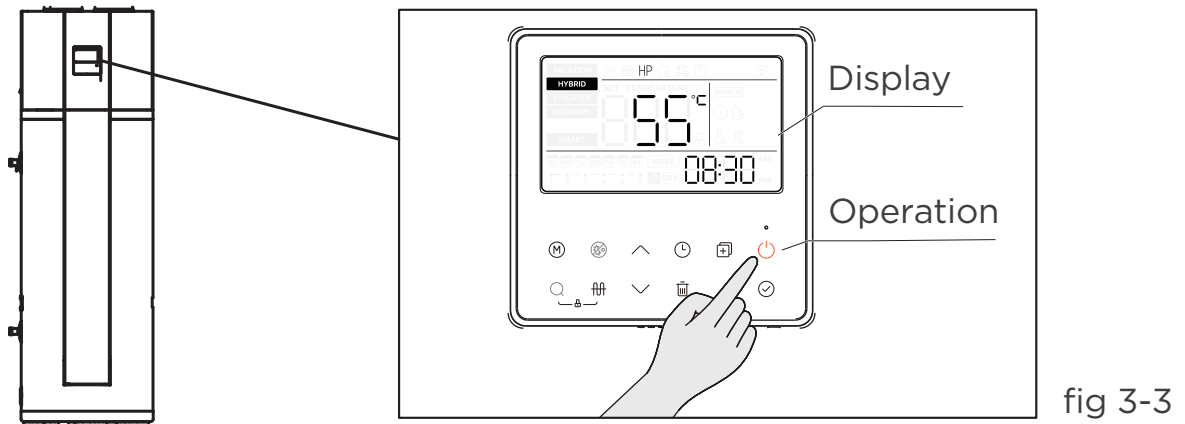

- Press → the unit will be switch on → press to select the set temperature (38-70°C) → press → The unit will automatically select heat source and start to heat water to set temperature.

● Change the running mode

Press the button to select running mode.

Running Modes:

Mode	Efficiency	Recovery
Vacation	N/A	N/A
Hybrid	Low	High
E-Heater	Very Low	Very High
Economy	High	Low
Smart	N/A	N/A

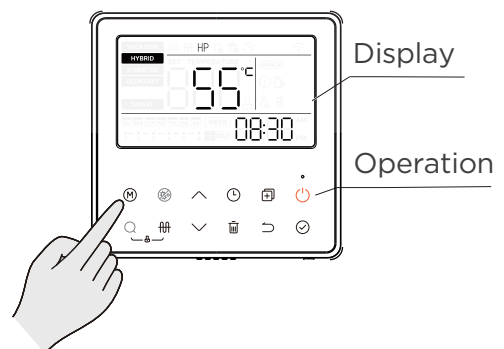

- **Date and time setting.**

In the main screen, press and hold L for 3 seconds to enter the weekday setting, press $\wedge \vee$ to select the date, press O to enter the time setting, use $\wedge \vee$ to modify the time. Press O to finish the setting and return to the main screen.

- The factory default setting gives priority to heat pump operation. During installation, it is necessary to make the operating mode selection settings with the customer and guide the customer in the use of the equipment.

3.3 About running

System structure figure

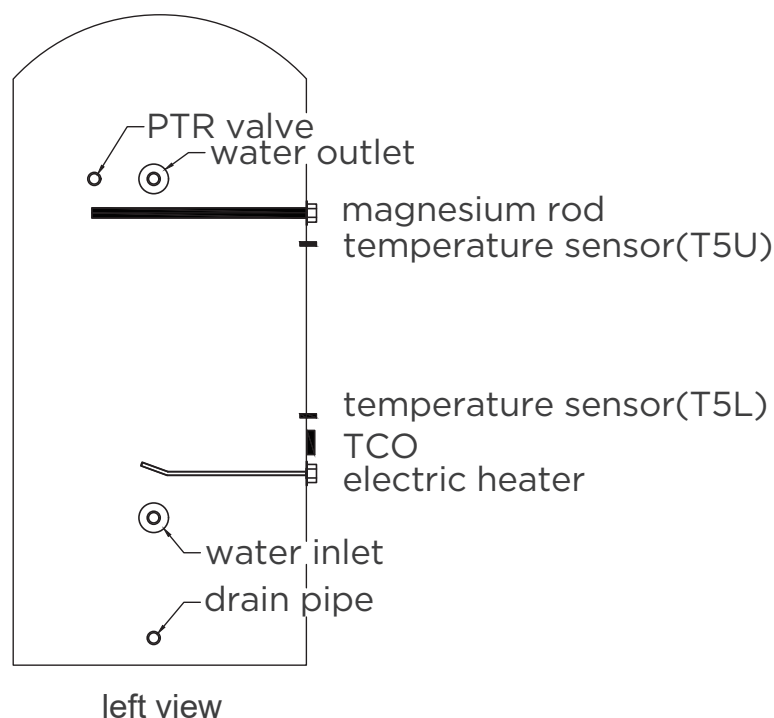

Water temperature display

The temperature shown on the display is the maximum of the temperatures registered by the upper sensor and the lower sensor. It is possible that once the display shows that the setpoint temperature has been reached on one of the sensors, compressor still running, because the water temperature around the other sensor does not get to set temperature.

Running temperature range

- Water set temperature range: 38°C ~ 70°C .
- Temperature of room of installation range: 0°C ~ 43°C .
- Heat pump running inlet air temperature range: -7°C ~ 43°C .
- E-heater running inlet air temperature range: -20°C ~ 46°C .

water temperature limits:

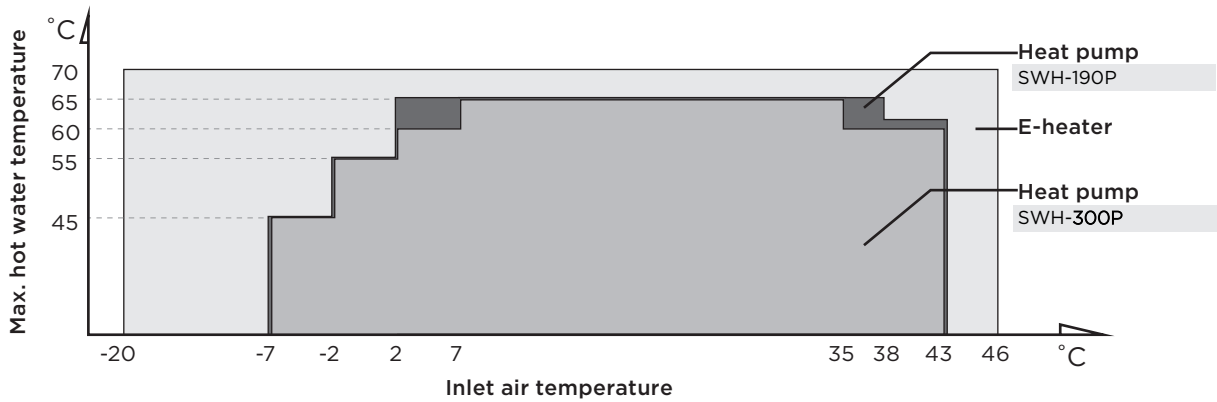

Heat source shift

- Unit has two kinds of heat sources: heat pump (compressor) and electric heater. Unit will automatically select heat sources to heat water to the target temperature.
- The default heating source is heat pump. If inlet air temperature is out of the range of heat pump, heat pump will stop running, the unit will shift automatically to activate E-heater, then if the inlet air temperature goes into the running range of heat pump again, it will stop E-heater and shift automatically to heat pump again.
- If the water set temperature is higher than Max. Temp (Heat pump), for the existing inlet air temperature, the unit will first activate the heat pump until Max. Temp (Heat Pump), then stop heat pump, and activate E-heater to heat the water continuously until the desired temperature is reached.
- Manually E-Heater operation is available. If manually activate the E-heater when heat pump running, E-heater and heat pump will work together until the water temperature gets to set temperature. So, if want to heat quickly, please manually activate E-heater.

NOTE

- E-heater will be activated once for the current heating progress, if want to apply E-heater again, please press **⏏** again.
- If only use E-heater, about only 150 liters water will be heated, so you must set a higher target water temperature if air temperature is out of heat pump running range and only the e-heater works.

Defrosting during water-heating

In heat pump running period, if the evaporator frosts in lower air temperature, the system will automatically defrost to keep effective performance (about 3-10min). At the time of defrosting the fan motor will stop, but compressor will continue to run.

Heat-up time

There are different heat-up times in different ambient temperature. Lower inlet air temperature result longer heat-up time because of lower effective performance.

When air temp below 2°C, heat pump and E-heater will take different portions of heating capacity, generally the lower of inlet air temperature, the lower portion of heat pump will be taken as well as the higher portion of E-heater will account for.

SWH-190P

Heat-up Time(h, water temperature 9 ~ 55°C)

		MODE		
		ECONOMY	HYBRID	E-HEATER
INLET AIR TEMP.(°C)	-7	14.9	4.6	4.6
	0	12.7	5.3	4.4
	2	11.4	5.1	4.2
	7	9.7	9.7	4.0
	15	7.3	7.3	3.5
	20	6.4	6.4	3.3
	25	6.1	6.1	3.2
	30	5.5	5.5	3.0
	32	5.2	5.2	2.9
	35	5.1	5.1	2.9
	40	4.4	4.4	2.7
		Highest efficiency	Medium efficiency	Highest consumption

SWH-300P

Heat-up Time(h, water temperature 9 ~ 55°C)

		MODE		
		ECONOMY	HYBRID	E-HEATER
INLET AIR TEMP.(°C)	-7	18.4	6.9	6.9
	0	17.7	7.4	6.5
	2	15.7	7.2	6.3
	7	14.4	14.4	5.9
	15	9.8	9.8	5.2
	20	9.0	9.0	4.9
	25	8.4	8.4	4.8
	30	7.4	7.4	4.5
	32	7.0	7.0	4.3
	35	6.7	6.7	4.3
	40	6.0	6.0	4.1
		Highest efficiency	Medium efficiency	Highest consumption

About TCO

The power of compressor and E-heater will be automatically shut-off or turn on by TCO. If the water temperature is higher than 85°C, the TCO will automatically shut off the power of compressor and E-heater. After that it needs to be reset manually.

Resetting TCO requires a qualified person, please contact the supplier or the after-sale service.

Restart after a long term stop

When the unit is restarted after a long term stop (trial running included), it is normal that outlet water is unclear. Keep the tap on and the water will be clean soon.

● NOTE

When the air inlet temperature is lower than -7°C, heat pump efficiency will decrease dramatically, the unit will automatically shift to E-heater running.

If system occurs some malfunctions

Error code “ EHHP ” and ⚠ will be shown on the display, and heat pump will stop

running. The unit will activate automatically E-heater as the backup heat source, but the code “ EHHP ” and ⚠ will be shown until power off Refer to[TROUBLE SHOOTING]for details.



Auto restart

If electricity power failed, the unit can memorize all setting parameters, unit will be back to the previous setting when power recover.

Buttons auto lock

When there is no operation of any button for 1 minute, button will be locked.

Screen auto lock

If there is no operation of button for 60s, screen will be locked (extinguished) . Push  +  simultaneously for 2s to unlock buttons. .Enter engineering mode 35 channel enable this function.

3.4 Control panel explanation

3.4.1 Display explanation

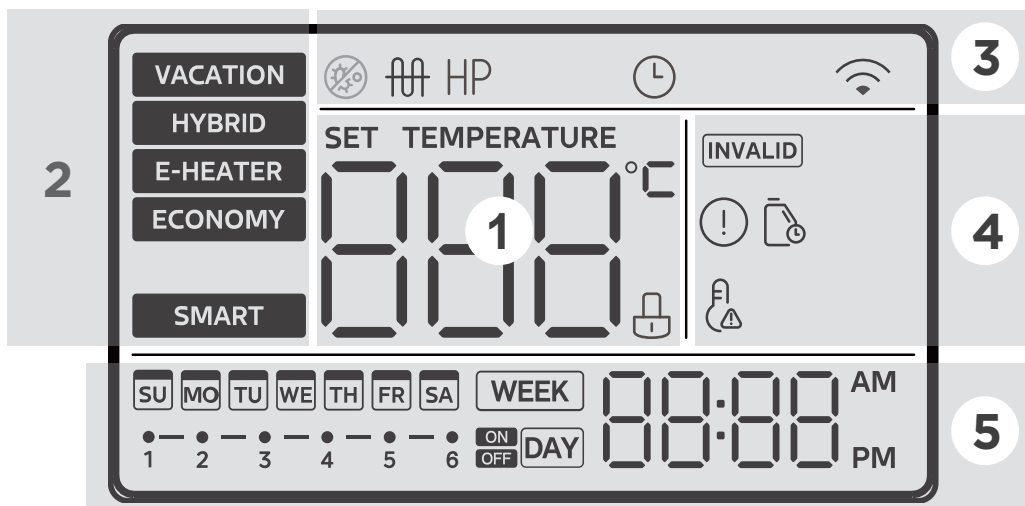











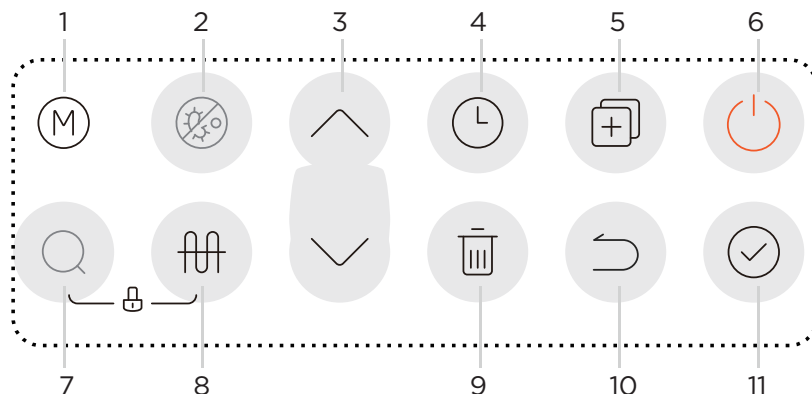

fig 3-5

Area	Icon	Description
1 Information		<p>00.00 will be lighted if screen is unlocked.</p> <p>It shows water temperature on normal;</p> <p>It shows setting temperature on setting process;</p> <p>It shows remaining vacation days on vacation mode;</p> <p>It shows unit setting/running parameters, error/protection code on querying.</p>
	SET TEMPERATURE	The icon lights up when the water temperature is being set.
		<p>Child lock:</p> <p>If button is locked, the icon will be lightened, otherwise it will be extinguished.</p>
2 Mode	VACATION	<p>VACATION MODE:</p> <p>For the vacation mode, the water temperature will be set at 15°C to keep a low energy consumption while preventing freezing in the tank.</p>
	HYBRID	<p>HYBRID MODE:</p> <p>Operating in heat pump mode, The unit will determine whether to turn on the e-heater according to the current state(when the water can not reach the set temperature only with heat pump).</p>
	E-HEATER	<p>E-HEATER MODE:</p> <p>Operate in accordance with the heat pump mode, the heat pump and the E-heater running at the same time.</p>
	ECONOMY	<p>ECONOMY MODE:</p> <p>It is recommended to use this mode of operation whenever possible, as it saves more energy. The heat pump unit heats up to the maximum water temperature before turning on the e-heater for heating, the heat pump and the e-heater will not be turned on at the same time.</p>
	SMART	<p>SMART MODE</p> <p>The smart mode will record the user's hot water usage habits in the past 7 days, heat the water in advance according to the user's water consumption time, and stay on standby(do not heat the water) at other times.</p> <p>(It is recommended that the user set this mode after 7 days of normal operation of the unit, so as to avoid the machine failing to record complete user habits and affecting the use experience)</p>

Area	Icon	Description
3 Function		It will be lighted when the machine is disinfecting.
		E-heater: It will be lighted when e-heater is running, otherwise it will be extinguished. NOTE: When the operating conditions are not met to turn on the e-heater, the corresponding icon will briefly light up and then goes off.
		Heat pump icon: When the heat pump is operating and producing hot water, the icon lights up.
		The icon lights up when the clock is being set.
		Wireless: ☎ will be lightened when Wireless is connected; ☎ will be extinguished when Wireless is not connected; ☎ will flash with 2Hz frequency when setting Wireless.
4 Warning		When any key is invalid, this icon will flash 3 sec.
		Error: It will be lightened when unit is under protection/error.
		It flashes to remind the user to maintain the water tank. If you do not need maintenance reminders, you can enter engineering mode channel 2 to disable this function, or engineering mode 4 to reset the maintenance reminder time, the default maintenance reminder time is 365 days.
		High temp. alarm If water temp is higher than 50°C, it will be lightened, otherwise it will be extinguished.
5 Timer		Time and clock setting It shows the clock.
		Schedule settings There is an option to set a schedule on weekly or daily basis. If no schedule is set, the appropriate part of the screen remains blank. Otherwise “WEEK” or “DAY” is displayed accordingly. During setting the corresponding icon (“WEEK” or “DAY”) is flashing.



3.4.2 Button explanation





NOTE

The unit will conduct a self-test within 10 seconds of being powered on, and it is recommended that no operations be performed during this time. Any pressing of button is effective only under button and display unlocked state. When the operating conditions are not met to turn on this function, the corresponding icon on the wire controller lights up briefly and then turns off.

1) Weekly disinfect function

Under disinfection unit immediately start to heat water up to 70°C to kill the potential legionella bacteria inside water of tank,  icon will light on the display screen during disinfection. Unit will quit disinfection if water temperature is higher than 70°C and extinguish  icon.













2) Vacation function

























Press  to select VACATION, then unit will automatically heat water to 15°C for the purpose of energy saving during vacation days. Press  to adjust vacation days and press  to make the setting effective.







3) Remote shutdown function

Users can connect a switch. If the switch is turned off, the unit will be stopped forcibly. If the switch breaks, the unit can run normally according settings.

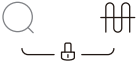

Detailed operating instructions

No	Icon	Description
1		MODE Press this button to switch mode. The default mode is ECONOMY mode ECONOMY ▶ E-HEATER ▶ SMART ▶ VACATION ▶ VACATION
2		Click the button to turn on the forced sterilization function.
3		UP & DOWN If screen is unlocked, press   to adjust corresponding value. While setting temperature/timer/vacation days, press more than 1s to change the value continuously. Press  to make the setting effective. On querying, use the buttons to switch check items.
4		TIMER Press  to select daily/weekly timer, and press  to enter the setting interface. Daily timer setting: When setting the daily timer, there is a total of 6 periods, each period has on/off time, mode and water temperature can be set (the default settings: energy saving mode, 60°C). • Set the target value for current period, and press  to enter the next, or press  to return previous setting. After all settings for all periods, press  again to

		<p>return to the main screen.</p> <ul style="list-style-type: none"> • While setting the [on/off time], you can restore to the default value (displaying-->) by pressing . • If there is a conflict between two time periods, settings of the later one will be valid, and the earlier one will be canceled and turn back to default values. • If you adjust a value again after all the setting is completed, then the settings after the adjustment period will be canceled and turn back to default values. • You can enter the timer setting in both power-on and power-off state. <p>Weekly timer setting:</p> <p>Weekly timer has a total of 7 days, press  to enter the setting of the selected day. Then it can be set by the same way as a daily timer.</p> <ul style="list-style-type: none"> • To copy the settings of one day to other days: While in the day selection, press  to copy a base day's settings, then select other days by pressing  again (the status will become fast flashing). Press  to confirm the operation and the settings will be copied to the selected days.
<p>5</p>	  <p>ENGINEERING MODE only for qualified person</p>	<p>COPY / ENGINEERING MODE</p> <p>In the main screen, press and hold  for 3 seconds to enter the engineering mode. Use  to switch the inspection channel, and the attribute value of the channel will be displayed. You can modify the parameter setting with , and after adjusting, press  to make the setting effective. Press  to return to the channel selection screen.</p> <p>After 30 seconds from the last operation, or by pressing the return key or the on/off key, you can directly exit the engineering mode.</p> <p>CAUTION</p> <ul style="list-style-type: none"> • It is strictly prohibited for the customer to change the parameter settings of other channels in the engineering mode without authorization to avoid affecting the normal operation of the unit or causing damage to the unit.
<p>6</p>		<p>POWER ON/OFF</p> <p>Press the button to start / stop the unit.</p>
<p>7</p>		<p>SEARCH / QUERY MODE</p> <ul style="list-style-type: none"> • In the main screen, press and hold  for 1 second to enter the query mode. Use  to switch the spot check channel, and the attribute value of the channel will be displayed, please refer to the following table for details. • After 30 seconds from the last operation, or by pressing  or , you can directly exit the query mode. • Query mode can be entered in both power-on and power-off state.
<p>8</p>		<p>If screen is unlocked, press this button to manually activate E-HEATER.</p>
<p>9</p>		<p>DELETE</p> <p>This key is used to cancel all settings and exit the setting state.</p> <p>When the wireless connection is working, long press  for more than 8s to exit Wireless connection.</p>
<p>10</p>		<p>RETURN</p> <p>Press the button to return to the previous setting or main screen.</p>
<p>11</p>		<p>CONFIRM</p> <p>If screen and buttons are unlocked, press it to upload setting parameters after setting any parameter.</p>

12		<p>CHILD LOCK</p> <ul style="list-style-type: none"> • In the main screen, long press the key combination for 2 seconds to enter the child lock state; • In the state of child lock, long press the key combination again for 2 seconds to release the child lock state; • In the locked state, there will be an icon  next to the water temperature display.
13	 Press for 3 sec	<p>Connecting the wireless function</p> <ul style="list-style-type: none"> • In the main interface, long press  for 3 seconds to enter the AP wireless network mode, there will be a  in the upper right corner of the line controller. At this time, enter the APP, select the category of air water heater, choose the correct model, and then network according to the APP prompts, and after the network is completed, the wireless icon  will be always on; • Wireless matching can last up to 8 minutes, after 8 minutes, if the matching is not successful, the wireless icon will go out; • Long press  for 8 seconds in the main interface to reset the wireless function; It can be set in both power on and power off state.

Query mode

Press and hold the  button for 1 second to enter query mode, then system running parameters will be shown one by one with following sequence by each pushing of   button, refer to the table below.









No.	parameters	unit	Explanation
1	T S U	Temp.	T5U
2	T S L	Temp.	T5L
3	T S I	Temp.	----
4	T S	Temp.	Heat pump stop water temp
5	T 3	Temp.	T3
6	T 4	Temp.	T4
7	T P	Temp.	TP
8	T H	Temp.	Th
9	o n		----
10	T F r		----
11	T T	Temp.	Disinfect temp.
12	ε o	Current	Compressor and electric heating current
13	F o	Fan	Ac Fan Dc Fan 0: OFF Real speed/10 1: LOW 2: MID 3: HIGH
14	ε o	Machine parameters	0~255
15	ε ε r		Electronic expansion valve opening
16	ε ε ε		Compression mechanism hot water demand
17	P U P		----
18	P S		----

No.	parameters	unit	Explanation
19	F T		0: Ac Fan 1: Dc Fan
20	H T		1(Eheater control type)
21	H P		0(Compressor control type)
22	F S I		---
23	S I o		Tank capacity
24	P 4 P		Four-way valve status
25	U U		0
26	U 1	Version	Host software version
27	U 2	Version	LCD panel software version
28	U 3	Version	000
29	U 4		0: One electric heater 1: Two electric heaters
30	U T		3
31	I E r		Last error code
32	2 E r		Previous 1 st error or protection code
33	3 E r		Previous 2 nd error or protection code
34	H H H		Maintenance time
35	T L F		Target Temp
36	ε n d		End sign

To turn on /off the electrical heater.

NOTE









- In order to avoid to affect the effectiveness of the hot water heating process, we recommend users not to turn off the electrical heater.

1	Long press  for 3 seconds to enter engineering mode and select F6 channel.	 	Press the up and down keys to operate
2	F6 set to 0 means the electrical heater is deactivated and will not turn on during heating time.	  	Press the up and down keys to operate Confirm
3	F6 set to 1 means the electrical heater is activated and will be turned on during heating time according to the need.	  	Press the up and down keys to operate Confirm

To active the Weekly disinfect function .

NOTE

- Weekly disinfect function activation will turn on the electrical heater. The factory setting is off (desactivated) by default.

1	Long press  for 3 seconds to enter engineering mode and select F7 channel.	 	Press the up and down keys to operate
2	F7 set to 0 means the weekly disinfect functions is turn off.	  	Press the up and down keys to operate Confirm
3	F7 set to 1 means the weekly disinfect functions turn on.	  	Press the up and down keys to operate Confirm

3.5 Use Your Appliance with the NetHome Plus App

⚠️ Ensure that your mobile phone is connected to the home wireless network, the 2.4GHz band wireless signal is enabled on your wireless router and you know the network password.

⚠️ Turn on Bluetooth on your phone and the device must also be powered up.

1 Download NetHome Plus App

CAUTION :

The following QR code is only available for downloading APP. It is totally different with the QR code packed with unit.

Android Phone users: scan Android QR code or go to google play, search “Nethome Plus” App and download it. IOS users: scan IOS QR code or go to APP Store, search “Nethome Plus” app and download it.



Android



IOS

2 Register or Login account

Open the App and create a user account, if you already have one, just log in.

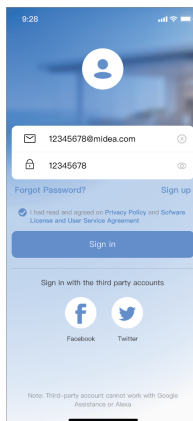

4 Choose Air Source Heat Pump Water Heater

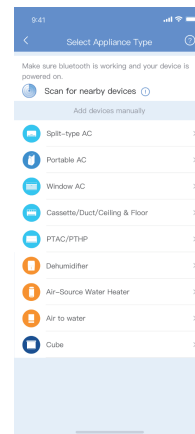

5 Connected to the network

Follow the instructions in the app to set up the Wireless connection. If the network connection fails, please refer to the App tips for operation. The actual UI design may look different from examples due to app updates.

3 Add your appliance

Tap the “+” icon to add home appliance to your NetHome Plus account.

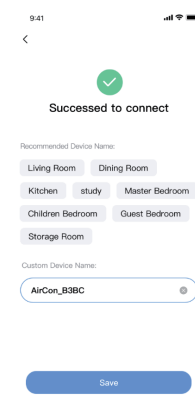
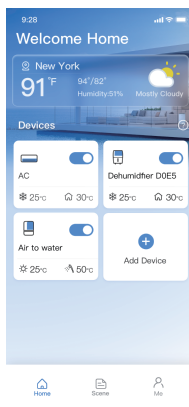

Compliance

We, hereby declare that this device is in compliance with the relevant provisions of RE Directive 2014/53/EU.

A copy of the full DoC is attached (European Union products only).

Wireless module models:

EU-SK110, US-SK110:

FCC ID: 2ADQOMDNA23

IC: 12575A-MDNA23

BLE:2402-2480MHz,

TX Power:<10dBm

Wireless:2400-2483.5MHz,

TX Power:<20dBm

This device complies with Part 15 of the FCC Rules and it contains licence exempt transmitter(s) / receiver(s) that comply with Innovation, Science and Economic Development Canada's licence-exempt RSS(s). Operation is subject to the following two conditions:

(1) This device may not cause harmful interference;

(2) This device must accept any interference, including interference that may cause undesired operation of the device.

Only operate the device in accordance with the instructions supplied.

Changes or modifications to this unit not expressly approved by the party responsible for compliance could void the user's authority to operate the equipment. This device complies with FCC radiation exposure limits set forth for an uncontrolled environment.

In order to avoid the possibility of exceeding the FCC radio frequency exposure limits, human proximity to the antenna shall not be less than 20cm (8 inches) during normal operation.

4. TROUBLE SHOOTING

4.1 Non-error tips

Q: Why can't compressor start immediately after setting?

A: The unit will wait for 3 minutes to balance the pressure of system before starting compressor again. It's a self protection logic of unit.

Q: Why dose the temperature shown on the display panel decreased sometimes while unit is running?

A: When the upper tank temperature is much higher than the bottom part, upper part hot water will be mixed by the bottom cold water which is continually flow from inlet tap water so that will decrease the upper part temperature.

Q: Why dose the temperature shown on the display sometimes decrease dramatically?

A: Because tank is pressure-bearable type, if here is massive hot demand, hot water will quickly tapped out from upper part of tank and cold water will quickly tapped into bottom part of tank. If the cold water surface emerge the upper temperature sensor, temperature shown on the display will decreased dramatically.

Q: Why dose the temperature shown on the display sometimes decrease a lot, but there is still a mount of hot water coming out?

A: Because the upper water sensor is located at the upper 1/4 of the tank, when temperature on the display starts decreasing, it means there is still 1/4 tank of hot water available.

Q: Why dose the unit sometimes shows " EHLA " on display ?

A: When the unit does not have electric heating function, the heat pump available running ambient air inlet range is -7~43°C. If ambient air inlet temperature is out of range, system will show above-mentioned signal to let user notice it.

Q: Why are the buttons sometimes unavailable?

A: if there is no operation on panel for 60s, the unit will lock the panel, shows "🔒". To unlock the panel, please press the "🕒"+"📅" button for 2 seconds.

Q: Why sometimes there is some water flow from drainage pipe of safety valve?

A: Because the tank is pressure-bearable one, when water is heated inside the tank, water will expand, so the pressure inside of tank will ncrease, if pressure goes up more than 0.85Mpa, safety valve will activate to relief the pressure and hot water drop will be discharged correspondingly. If water drop is continually discharged from safety valve drainage pipe, it is abnormal, please contact qualified person to repair it.

4.2 Something about the self-protection of unit

- 1) When self-protection happens, the system will be stopped and start self-check, and restart when the protection resolved.
- 2) When the self-protection happens, the ① will flash and error code will be shown at water temperature indicator. But the ① and error code does not disappear until protection resolved.
- 3) In the following circumstance, self-protection may happen: Air inlet or outlet is blocked.

The evaporator is covered with too much dust; Incorrect power supply(exceeding the range of 220-240V).

4.3 When Error happened

- 1) If some normal errors happen, the unit will automatically shift to E-heater for emergent SHW supply, please contact qualified person to repair it.
- 2) If some serious error happen, unit will not start, please contact qualified person to repair it.

4.4 Error phenomenon shooting

Error phenomenon	Possible reason	Solution
Cold water was tapped out and display screen was extinguished	<ol style="list-style-type: none"> 1. Bad connection between power supply plug and socket; 2. Setting the water temperature too low; 3. Temp. sensor broken; PCB of indicator broken. 	<ol style="list-style-type: none"> 1. Plug in; 2. Setting a higher temperature; 3. Contact service center.
No hot water was tapped out	<ol style="list-style-type: none"> 1. Public water supply ceased; 2. Cold water inlet pressure is too low (<0.15 MPa); 3. Cold water inlet valve closed. 	<ol style="list-style-type: none"> 1. Waiting for public water supply to recover; 2. Waiting for inlet water pressure to increase; 3. Open water inlet valve.
Water leakage	Hydraulic pipeline joints are not sealed well.	Check and reseal all joints.

4.5 Error code shooting table

Display	Malfunction Description	Corrective Action
EH0b	Tank and LCD panel communication error.	Maybe the connection between LCD panel and PCB has released or PCB has been broken.
EH00	Machine working parameters are abnormal.	Contact a qualified person to service the unit.
EH03	DC fan fault.	Maybe the connection between fan and PCB has released or fan has been broken. Contact a qualified person to service the unit.
PH15	Electric leakage error. If PCB current_induction_circuit check the current difference between L,N > 14mA, system consider it as "electric leakage error".	If some wires have been broken or bad wire connection. Contact a qualified person to service the unit.
EC54	Compressor discharge temperature sensor TP error.	Maybe the connection between sensor and PCB has released or sensor has been broken. Contact a qualified person to service the unit.
EH5H	Compressor suction temperature sensor TH error.	
EC53	Ambient temperature sensor T4 error.	
EC52	Evaporator temperature sensor T3 error.	
EH5L	Error of sensor T5L (lower water temperature sensor).	
EH5U	Error of sensor T5U (upper water temperature sensor).	
EHLA	When the ambient temperature T4 is out of the compressor operating range, the compressor stops, and EHLA is displayed until T4 returns to the normal range. Only works on units without electric heaters. Devices with electric heaters will never display "EHLA".	It is normal, and no necessary to repair.
EH5d	Electric heater open-circuit error.	If the electric heater has been broken or bad wire connection after repair.
EHHP	Heat pump system fault. When PH20, PH21, PC30, PC06 any protection appears 3 times or the protection lasts 1 hour.	The compressor works abnormally. Contact a qualified person to service the unit.
PHdH	Dry burning protection.	Ensure that there is water in the water tank before heating.
PH20	Compressor abnormally stopped protection. The discharge temperature is not so higher than evaporator temperature after compressor running a term.	Maybe because of compressor broken or bad connection between PCB and compressor. Contact a qualified person to service the unit.
PH21	The working current of the compressor is too large.	Maybe because of compressor broken, system blocked, air or water or more refrigerant in system(after repair), water temperature sensor malfunction, ect. Contact a qualified person to service the unit.
PH24	Frost protection. T5L < 4°C and T4 < 7°C.	The cold water temperature is too low, which will affect the water tank. The electric heater will work.
PC30	System high pressure protection ≥ 3.0 MPa active; ≤ 2.4 MPa inactive	Maybe because of system blocked, air or water or more refrigerant in system(after repair), water temperature sensor malfunction, ect. Contact a qualified person to service the unit.
PC06	High TP protection. Tp > 110°C (185L) Tp > 105°C (275L) .Protection active; Tp < 90°C Protection inactive.	Maybe because of system blocked, air or water or less refrigerant(leakage) in system(after repair), water temperature sensor malfunction, ect. Contact a qualified person to service the unit.
PH9b	Overtemperature protection. The current water temperature exceeds the Maximum target temperature by more than 5°C .	The water temperature sensor is faulty or the current water temperature is too high. In case of burns, contact a qualified person to check.
PH91	Low T3 protection.	If the fault persists. Contact a qualified person to service the unit.

5. MAINTENANCE

CAUTION

Always turn off your Air-source Heat Pump Water Heater system and disconnect its power supply before cleaning or maintenance.

- Check the connection between the power supply plug and socket and ground wiring regularly;
- It is recommended to set a lower temperature if the outlet water volume is sufficient, to decrease the heat release, prevent scale and save energy.
- If the system will be stopped for a long time, please do as follows to avoid freezing of inner tank and damage of E-heater:
 - Shut off the power supply;
 - Release all the water in water tank and the pipeline and close all the valves;
 - Check the inner components regularly.
- Clean the air filter every month in case of any inefficiency on the heating performance. In terms of the filter set in air inlet directly (namely, air inlet without connecting with duct):
 - Unscrew the air duct connector anti-clockwise.
 - Take out the filter and clean it completely;
 - Remount it to the unit.

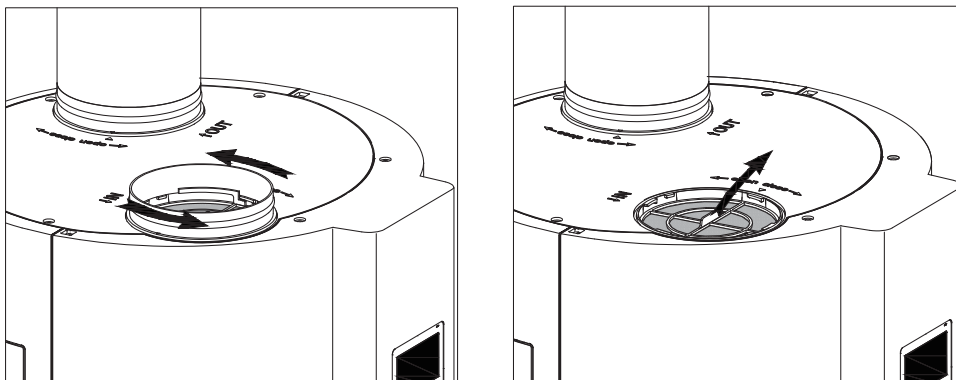
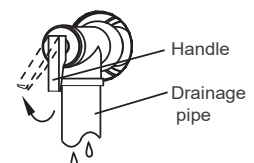

fig 5-1

- Operate and check the PTR valve every 6 months to prevent blockage.



CAUTION

The following maintenance items need to be performed by qualified persons. Please contact the supplier or the after-sale service.

- It is recommended to clean the E-heater every 6 months to maintain efficient performance.
- Check the Magnesium rod every 6 months and change it if it has been used out.
- Please contact professional technical after-sales service if the battery needs to be replaced.

Recommended regular maintenance table

Checking Item	Checking Content	Checking Frequency	Action
1	Air filter(inlet)	Every month	Clean the filter
2	E-Heater	Every 6 months	Clean the E-Heater
3	Magnesium rod	Every 6 months	Replace it if it has been used out
4	PTR valve	Every 6 months	Check for blockage

For more details, please contact the supplier or the after-sale service.

DISPOSAL AND RECYCLING

Important instructions for environment (European Disposal Guidelines)

Compliance with the WEEE Directive and Disposing of the Waster Product:
This product complies with EU WEEE Directive (2012/19/EU). This product bears a classification symbol for waster electrical and electronic equipment (WEEE).

This symbol indicates that this product shall not be disposed with other household wastes at the end of its service life. Used device must be returned to official collection point for recycling of electrical electronic devices. To find these collection systems please contact to your local authorities or retailer where the product was purchased. Each household performs important role in recovering and recycling of old appliance. Appropriate disposal of used appliance helps prevent potential negative consequences for the environment and human health.

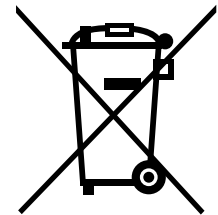

WARNING

- Battery must be disposed of properly. Do not short circuit or dispose of in the fire.
- Keep batteries out of the reach of children.
- Caution for ingestion.
- Non-rechargeable batteries are not to be recharged.
- Exhausted batteries are to be removed from the product.
- Dispose of the old batteries in the special containers to be found in the sales outlets.
- Replace the battery must contact the supplier or the after-sale service.

NOTE CONCERNING PROTECTION OF ENVIRONMENT

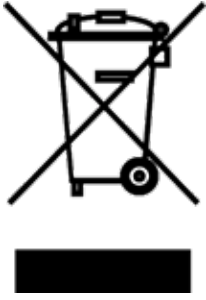

This product must not be disposed of via normal household waste after its service life, but must be taken to a collection station for the recycling of electrical and electronic devices. The symbol on the product, the operating instructions or the packaging indicate such disposal procedures. The materials are recyclable in accordance with their respective symbols. By means of re-use, material recycling or any other form of recycling old appliances you are making an important contribution to the protection of our environment. Please ask your local council where your nearest disposal station is located.

INFORMATION CONCERNING USED REFRIGERANT MEDIUM

The maintenance and the liquidation must be carried out by qualified personnel.

Type of refrigerant: R290

The quantity of the refrigerant: Please see the unit label.

The value GWP: 3

GWP = Global Warming Potential



Appliance filled with flammable gas R290

In case of quality problem or other please contact your local supplier or authorized service center.

Emergency number: 112

PRODUCER

SINCLAIR CORPORATION Ltd.

16 Great Queen Street

WC2B 5AH London

United Kingdom

www.sinclair-world.com

This product was manufactured in China (Made in China).

REPRESENTATIVE

SINCLAIR Global Group s.r.o.

Purkynova 45

612 00 Brno

Czech Republic

TECHNICAL SUPPORT

SINCLAIR Global Group s.r.o.

Purkynova 45

612 00 Brno

Czech Republic

Tel.: +420 800 100 285 | Fax: +420 541 590 124

www.sinclair-solutions.com | info@sinclair-solutions.com



