

„ORIGINAL INSTRUCTIONS“

**IMPORTANT NOTE:**

Read this manual carefully before installing or operating your new heat pump.  
Make sure to save this manual for future reference.

## Table of contents

1.	SAFETY TIPS.....	3
2.	RECORD RETENTION .....	3
3.	SYMBOLS USED .....	3
4.	GENERAL INFORMATION .....	3
5.	SERVICE.....	4
5.1	CONFIGURATION.....	4
5.2	OPERATION AND DIAGNOSTICS .....	5
6.	ELECTRICAL CONNECTION .....	7
7.	HYDRAULIC DIAGRAM .....	9
8.	ASSEMBLY .....	10
8.1	MODULE .....	10
8.2	BYPASS .....	10
8.3	TEMPERATURE SENSOR .....	11
9.	TECHNICAL DATA.....	13
10.	STORAGE AND TRANSPORT CONDITIONS .....	13
11.	MAINTENANCE, HEALTH CHECK AND BATTERY HANDLING .....	14
12.	WEEE DIRECTIVE 2012/19/EU .....	14

## 1. Safety Tips

Proper installation and operation are the prerequisites for the correct operation of the device. Please comply with the following requirements.



- The kit must only be installed by a qualified person.
- A live electrical device. Before performing any power-related operations (wiring, installing the device, etc.), make sure that the device is not connected to the mains.
- The appliance is not intended for use by children.
- The appliance must not be used for other than its intended purpose.
- Lightning can damage the controller, so during a thunderstorm, you should turn it off from the mains by removing the mains plug from the socket.
- Due to the nature of the device and the safety of use, its technical condition should be checked regularly.
- It is forbidden to operate the device if its housing is damaged or if the battery or any of the components is damaged.

## 2. Record retention

Please keep this manual carefully. If you move or sell the unit, you must pass on the enclosed documentation to the new owner.

## 3. Symbols used

The following symbols are used in the manual:



- The symbol indicates additional advice and information.



- The symbol indicates important information.

Note: Symbols are used to mark important information to make it easier to read the manual. However, this does not exempt the user from complying with requirements not marked with symbols.

## 4. General information

The SR-AFS is a complete set for emergency forcing of water circulation in a monoblockheat pump system with water as the heat transfer medium. It provides protection against freezing of water in the heat pump in the event of a power outage, immobilization (e.g. due to a flow error) and activation of current protections.

Features:

- frost protection of the heat pump upper source system by means of a bypass pump,
- preventing the bypass pump from stagnating,
- replacement of the overdrive of the upper source pump in the event of a power outage, if necessary,
- maximum operating time thanks to the fact that the bypass pump can be switched on depends on the outside temperature - the time at which the bypass pump is switched on depends on the outside temperature,
- function of limiting the pump operation bypass from the water temperature (no pump operation after reaching the set water temperature, taking into account hysteresis),

- acoustic signaling of alarm conditions,
- detection of bypass pump alarm states (lack of pump operation despite its control, excessive current consumption by the pump),
- detection of excessive battery discharge and in the event of its occurrence, information about the need to replace the battery with a new one,
- self-diagnostics of the electronic system and signaling of the correct connection of the system,
- algorithm for optimal battery charging dependent on changes in the external temperature of the system,
- diagnostic counters that allow you to analyze alarm situations and predict the need to replace the battery,
- cooperation with heat pump controllers and the S-therm remote Internet module,

## 5. Service

### 5.1 Configuration

#### SW1 connector:

For the basic configuration of the controller, a jumper on the SW1 connector of the controller is intended.

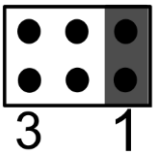
Jumper Position	Description
	item 1 - unused. item 2 - clearing of battery over-discharge alarms. item 2 - blocking the sound alarm signal until the service technician arrives. item 3 - switching off continuous sound signalling of alarms.

#### S-therm remote internet module:

Readings, **visualization of operation, configuration of operating parameters of the system with a connected heat pump is possible through the <https://s-thermremote.com> website and S-therm remote** mobile application for this pageabout connection to the S-therm remote internet module controller.

The mobile app can be downloaded from the QR code or link below.

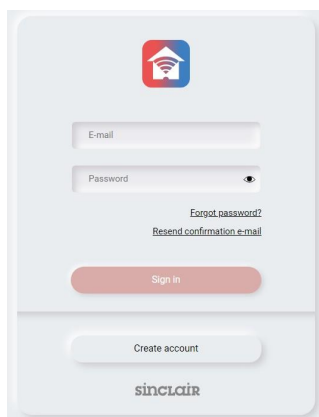

<https://s-thermremote.com>

Android



[S-therm remote](#)

iOS



[S-therm remote](#)



The connection to the SR-AFS system (controller) and to the heat pump controller (the "Modbus" device) and the configuration of the S-therm remote internet module is described in the internet module's main manual.

## 5.2 Operation and diagnostics

Proper operation of the system is signaled by a green LED indicating the presence of mains power and a flashing of a red LED (LED time 1 second, break time 3 seconds).

- **Control mode** – when the temperature on the T1 outdoor temperature sensor drops below 3°C, the control mode is activated, in which the temperature is checked once an hour, while the bypass/circulation pump is activated. As the outside temperature drops below 3°C, the downtime periods of the bypass pump are shortened in order to control the temperature of the water system more reliably.
- **Anti-freeze mode** – when the recorded temperature on the T2 water sensor drops below the critical value of 4°C, the bypass/circulation pump operates according to a 3K hysteresis.
- **Summer mode** – once a day, the bypass/circulation pump is activated as part of the function to prevent impeller blockage.

Alarm states are signaled by sound and by a sequence of flashes of a red LED corresponding to a given alarm state number. In the event of more than one active alarm, the first alarm is signaled first, followed by the next ones. Alarms are signaled until the alarm is cleared or the cause of the alarm is removed (e.g. repair of a damaged sensor cable). In the event of a power failure (operation in battery backup mode), the acoustic signaling is switched off to ensure that the system operates on emergency power for as long as possible.

LED Sequence	Description	Action
1 short flash, 5 second pause (no beep)	no power supply	In the event of a power outage, the message is for informational purposes, otherwise check the power supply.
2 short flashes, 5 second pause (beep)	Short circuit detected on the pump	Check the correct connection of the circulation pump cable to the controller, otherwise the circulation pump may fail – contact the manufacturer's service.
3 short flashes, 5 second pause (beep)	Opening detected on the pump	Check the correct connection of the circulation pump cable to the controller, otherwise the circulation pump may fail – contact the manufacturer's service.
4 short flashes, 5 second pause (beep)	Charging voltage too high	Possible failure of the charge controller – contact the manufacturer's service.
5 short flashes, 5 second pause (beep)	the battery has been discharged below a critical value	Possible damage to the battery due to deep discharge, capacity checks and possible replacement recommended. Alarm reset possible by removing jumper no. 2 on connector SW1.
6 short flashes, 5 second pause (beep)	damage to the T1 outdoor temperature sensor	Check the continuity of the sensor wires, alternatively verify the resistance for the CT10.
7 short flashes, 5 second pause (beep)	T2 water temperature sensor damage	Check the continuity of the sensor wires, alternatively verify the resistance for the CT10.

---

 If you need to mute the acoustic signal (e.g. until the technician arrives), it is possible to turn off the buzzer by removing jumper No. 3 on the SW1 connector.

---

 Error reset is possible by removing jumper no. 2 on connector SW1 for 30 seconds (provided that the cause has been removed).

---

## 6. Electrical connection

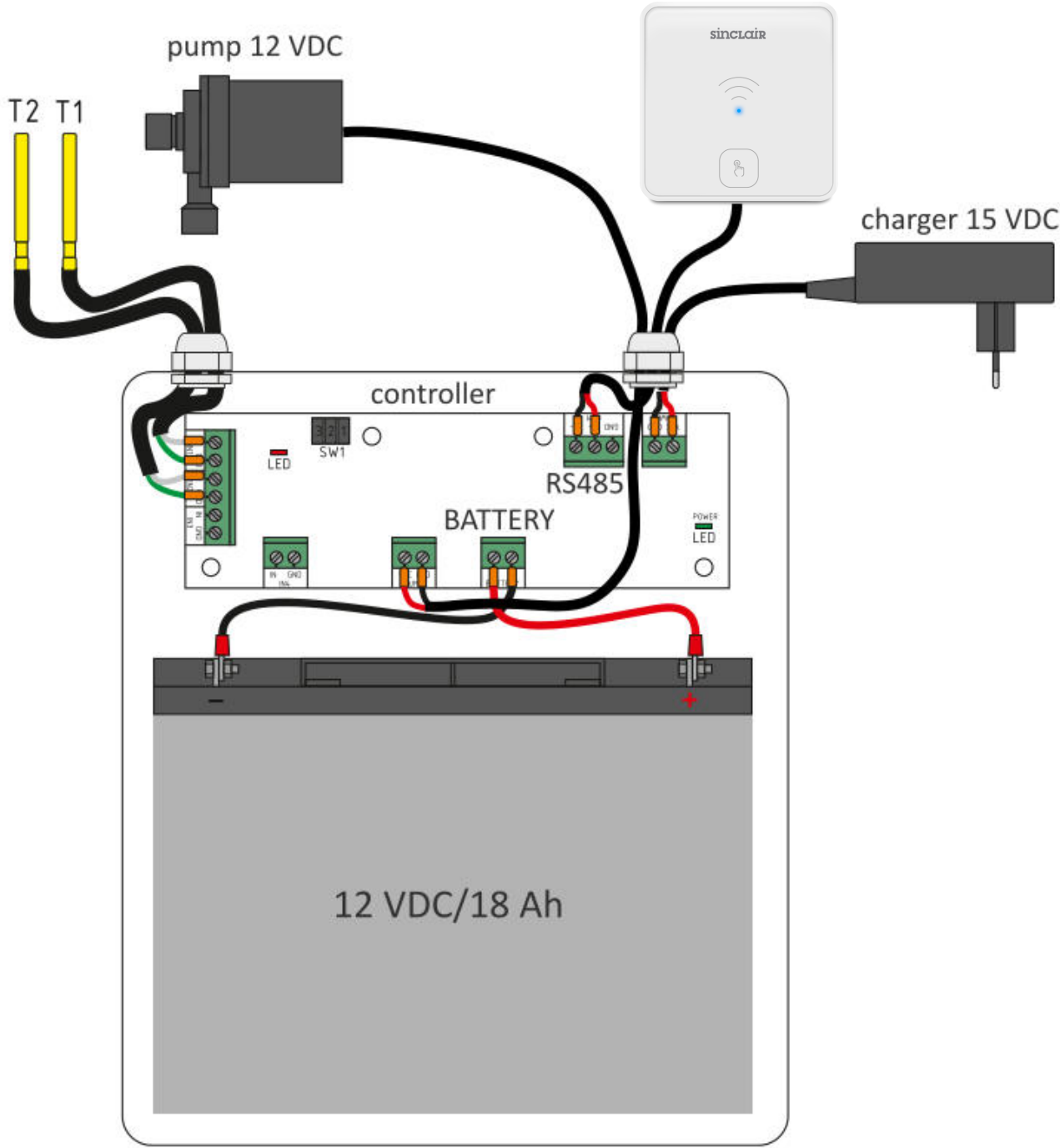

The cables must be routed through the glands of the module housing. Make sure that it is not possible to pull out the cables after they have been clamped in the glands.

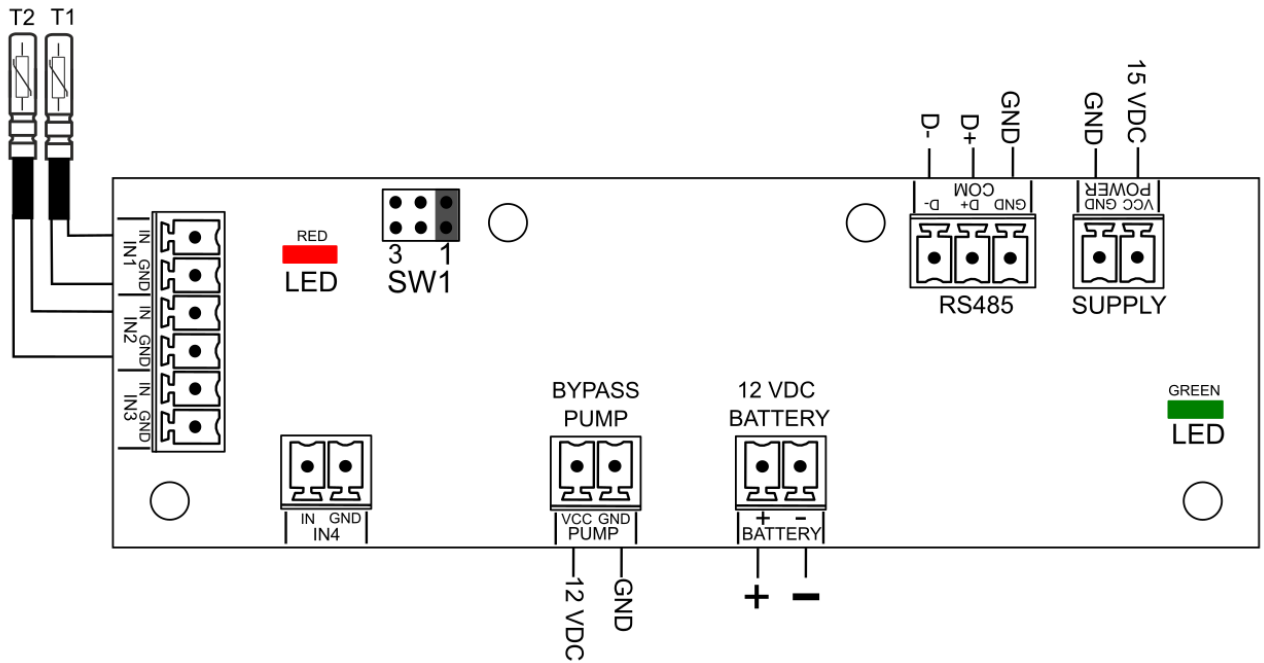

Terminals		Description
POWER	VCC, GND	Power supply 15 VDC, 1 A
COM	GND, D+, D-	RS485 Transmission: - S-therm remote Internet module, - heat pump controller,
T1	IN1, GND	Outdoor temperature sensor type CT10 - is required
T2	IN2, GND	CT10 type water temperature sensor in the upper source circuit (downstream of the heat pump) – required
T3, T4	IN3, GND IN4, GND	Not connected.
PUMP	VCC, GND	Bypass pump power supply.
BATTERY	+, -	External 12 VDC battery. The battery used should be of the buffer type.



All wires connected to the terminals of the controller should be fastened so that accidental falling out of one of the wires cannot cause danger or damage to the controller.

The controller is equipped with plugged-in screw terminal connectors, adapted to accept a wire with a ferrule terminal. The ends of the conductors must be protected against delamination, e.g. by insulated crimping sleeves. Use the cable diameters and tightening torques of the screw terminals specified in the technical data.

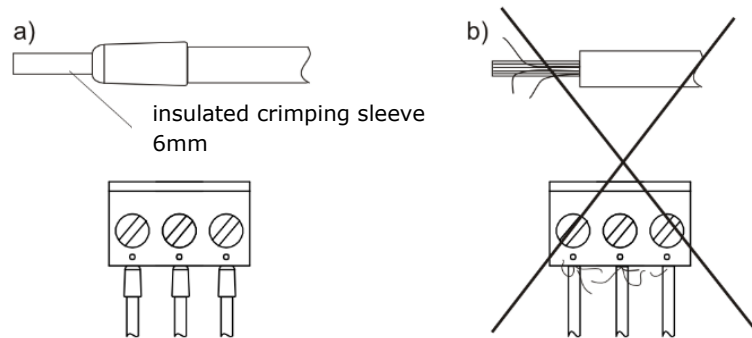

Securing the ends of the wires: a) - correct, b) - incorrect.

## 7. Hydraulic Diagram

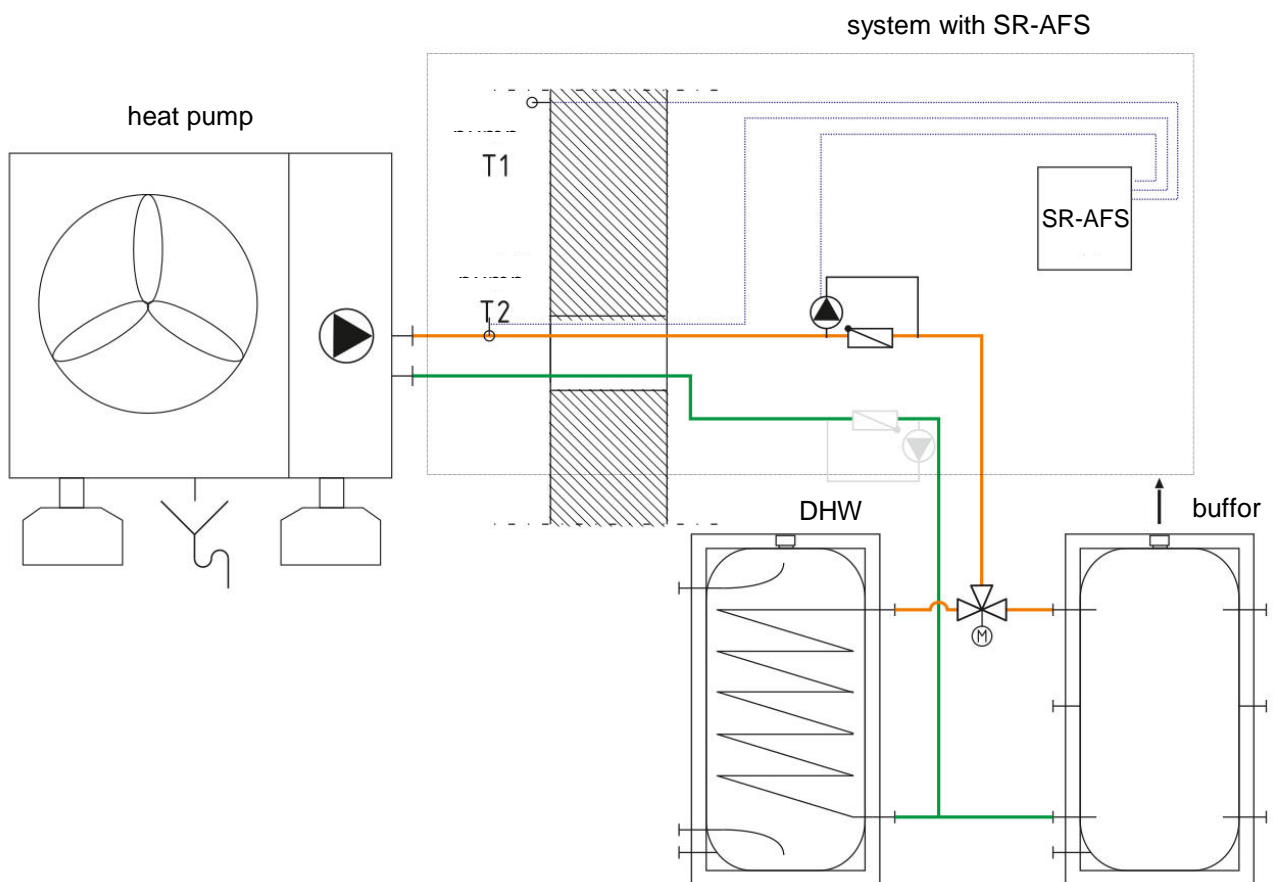

An example of a hydraulic diagram.

When building a hydraulic system, we must ensure that the flow is possible regardless of the position of the zone valve at the time of power failure. Therefore, in the case of systems with or without a buffer connected in series, we can provide heat collection, e.g. from short underfloor heating loops not controlled by an actuator, or make a bypass for a DHW tank with an electroless open solenoid valve, which will open after a power failure.

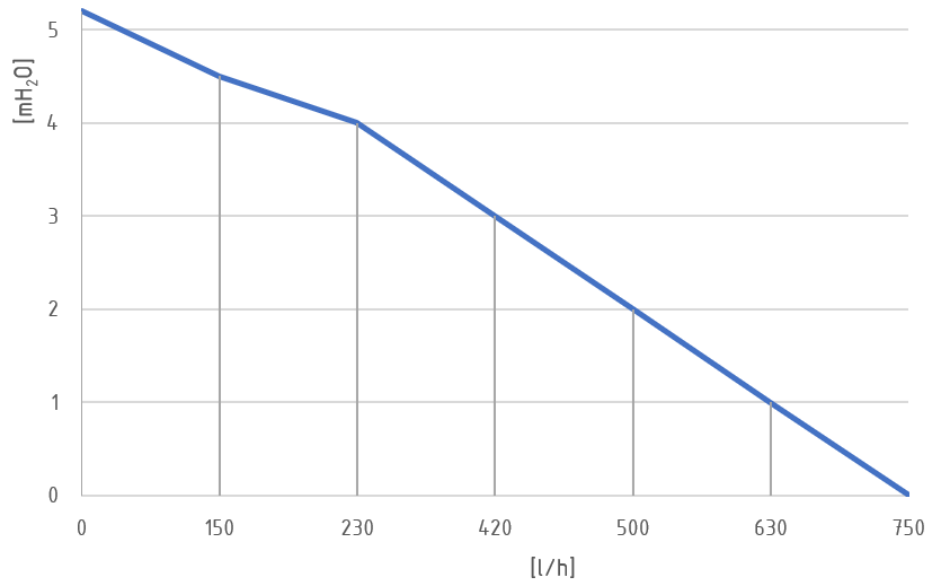

Bypass/circulation pump characteristics.

## 8. Assembly

The module can only be installed indoors, in a dry and clean place, and the room temperature should not exceed 25°C or lower than 15°C. Operation outside this range reduces the life of the battery and reduces its capacity. Do not install the device near heat sources, protect from fire and spark fall.

### 8.1 Module

The module should be hung on the wall using wall plugs with screws, paying attention to the correct mounting orientation, i.e. the battery in the lower part and the controller in the upper part. In the controller, verify and possibly connect the pump power supply (PUMP) and temperature sensors T1 (IN1) and T2 (IN2). **Then plug in the battery plug (BATTERY)** and insert the charger into the power socket.

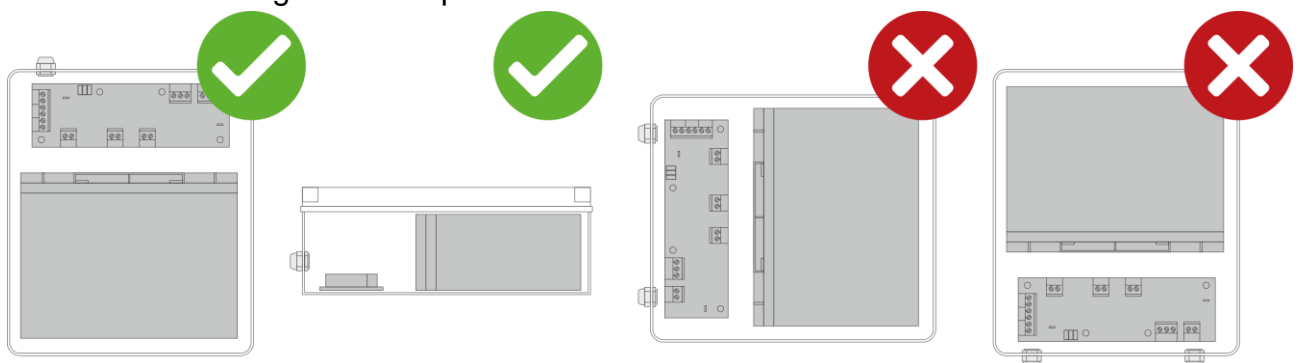

### 8.2 Bypass

The bypass included in the set should be mounted on the supply or return pipe section between the buffer and the heat pump, taking into account the correct flow direction. Both the check valve and the bypass/circulation pump must be installed so that the check valve flap is in the vertical position and the axis of the bypass pump impeller in the horizontal position for proper operation. It is also recommended to install the system in such a way that

the bypass pump connection hose is below the level of the main pipe, which will allow the system to vent without any problems.



Careful and effective insulation of the pipeline to the outside will significantly extend the operating time of the system on the battery backup. If possible, it is also worth insulating the condenser.



Make sure that the bypass is well vented and that there are no components in the circuit that can generate insurmountable resistance from the enclosed bypass/circulation pump.

### Example of correct bypass setup:



### Examples of incorrect bypass setting:



Pump impeller vertically, difficult venting.



Risk of noise in the non-return valve.

## 8.3 Temperature sensor

The T1 outdoor temperature sensor should be placed outside the building, away from sunlight, in a way that allows reliable identification of the ambient temperature (e.g. on the outside wall or on the outside of the insulated pipeline). The T2 heating water temperature sensor should be placed as close as possible to the heat pump on the outlet pipe, directly on the pipe under the insulation layer or in a suitable capillary. For pipes made of a material that is poorly thermally conductive, e.g. PP-R, it is advisable to find another sensor location, e.g. on a metal fitting, and insulate it effectively. Each of the sensors can be extended to 15 m of total length using a cable of min.  $2 \times 0.75 \text{ mm}^2$ . If running with a power harness, it is essential to use a shielded cable. It is not allowed to flood the temperature sensors with oil or water.

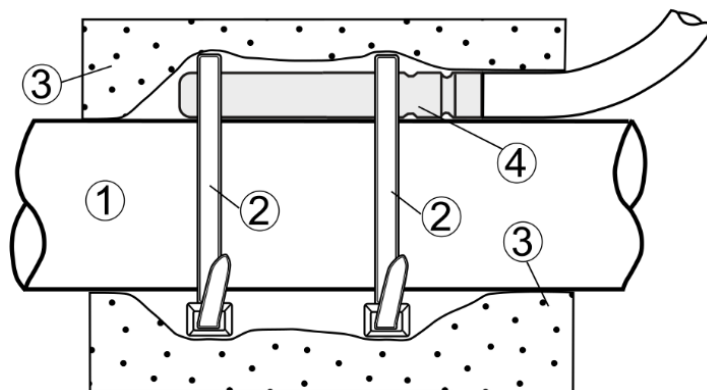

Temperature sensor installation: 1 - pipe, 2 - cable tie, 3 - thermal insulation (insulation cover), 4 - temperature sensor.



It is imperative to ensure that temperature sensors T1 and T2 are correctly identified. Incorrect connection of temperature sensors can result in improper system operation and lack of frost protection of the heat pump.

### Checking the temperature sensor:

Checking the temperature sensor is done by measuring its resistance at a given temperature. If there are significant differences between the measured resistance value and the values in the table below, the sensor should be replaced.

CT10	
Ambient Temp. [°C]	Name.[Ω]
-30	175200
-20	96358
-10	55046
0	32554
10	19872
20	12488
30	8059
40	5330
50	3605
60	2490
70	1753
80	1256
90	915.4
100	677,3
110	508,30
120	386,60

## 9. Technical data

Case	Plastic		
Dimensions	248 x 196 x 96 mm		
Scales	5.5 kg		
Battery capacity	18 Ah		
Permissible ambient temperature range	-20...+60°C		
Optimal ambient temperature	25°C, +/- 5°C		
Runtime in water maintenance mode	Thu 48 h		
Measuring range of the CT10 temperature sensor	-40...+60°C, +/- 2°C		
Screw terminals	Wire cross-section: 0.25... 1.5 mm <sup>2</sup> , 0.2 Nm tightening, 7 mm stripping		
Battery charging power supply			
Output voltage	15 VDC		
Input voltage	100... 240 VAC / 50... 60 Hz		
Charging	1 A		
Bypass/circulation pump			
Supply voltage	12 V DC		
Maximum power	19 watts		
Maximum flow rate	800 L/h		
Maximum Water Column Lift	5 m		
Noise	< 35 dB		
Permissible operating temperature range	0... 60°C		
A set of fittings for the bypass			
Optional equipment version	DN25	DN32	DN40
Connection hose	1/2"	1/2"	1/2"
T-piece connections	1" female thread	1 1/4" female thread	1 1/2" female thread
Valve	1" flap	1 1/4" flap	1 1/2" flap

The set consists of: controller, battery, power supply for charging the battery, bypass pump, 2 connected temperature sensors type CT10 3m, set of fittings for mounting the bypass pump.

## 10. Storage and transport conditions

Store the devices in a dry, cool (above 0°C) and clean place. Depending on the storage temperature, the batteries self-discharge (up to 3% per month at 25°C – the higher the temperature, the faster). The self-discharge rate increases at higher temperatures, and after exceeding 3 months of storage, a refreshing charge should be performed.

## 11. Maintenance, health check and battery handling

Before the start of the heating season, it is recommended to observe the operation of the system, i.e. the operation of the bypass/circulation pump, verify the correct venting of the system and commission a specialist to perform a battery capacity test.

If the battery needs to be replaced, observe the following guidelines:

- entrust the replacement of the battery to an authorized service center or authorized electrician,
- remove metal personal belongings such as rings, bracelets, necklaces or watches when working with batteries,
- the charging voltage compensation algorithm is developed for batteries with a rated voltage of 12 VDC VRLA type in AGM technology with a capacity of 18-20 Ah – lithium-ion and other types of batteries must not be used as a substitute!
- before replacing the battery, remove the charger from the mains socket and the plug (BATTERY) from the socket in the controller,
- When connecting a new battery with special care, please pay attention to the correct polarity (+ and - markings), shorting the terminals is strictly prohibited!
- the used battery must not be disposed of in the garbage and must be delivered to a dedicated disposal point,
- Under normal operating conditions, there is no possibility of contact with the electrolyte, but due to damage by the safety valves, leakage may occur - then, in the event of skin contact, the area should be rinsed with plenty of water, and the damaged battery should be disposed of, remembering to use protective gloves and goggles.



If the system is to remain without power for an extended period of time or is to be stored, disconnect the battery to protect against complete discharge and accelerated battery wear.

---

## 12. WEEE Directive 2012/19/EU

The product you have purchased is designed and made with the highest quality materials and components that are recyclable and can be reused. The product meets the requirements of **Directive 2012/19/EU of the European Parliament and of the Council of 4 July 2012 on waste electrical and electronic equipment (WEEE)**, according to which it is marked with the symbol of a crossed-out wheeled waste container, informing that it is subject to selective collection.



Responsibilities at the end of the product's useful life: dispose of the packaging and the product at the end of the useful life at a suitable recycling company, do not dispose of the product with normal waste, do not incinerate the product.

By complying with the above obligations of controlled disposal of waste electrical and electronic equipment, you avoid harmful effects on the natural environment and threats to human health.

### Changelog:



The manufacturer reserves the right to make improvements and modifications to the device.

---

## NOTE CONCERNING PROTECTION OF ENVIRONMENT

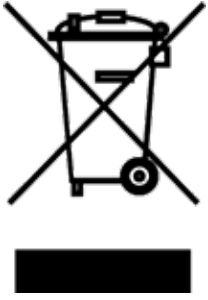

This product must not be disposed of via normal household waste after its service life, but must be taken to a collection station for the recycling of electrical and electronic devices. The symbol on the product, the operating instructions or the packaging indicate such disposal procedures. The materials are recyclable in accordance with their respective symbols. By means of re-use, material recycling or any other form of recycling old appliances you are making an important contribution to the protection of our environment. Please ask your local council where your nearest disposal station is located.

In case of quality problem or other please contact your local supplier or authorized service center.

**Emergency number: 112**

### PRODUCER

SINCLAIR CORPORATION Ltd.  
16 Great Queen Street  
WC2B 5AH London  
United Kingdom  
[www.sinclair-world.com](http://www.sinclair-world.com)

This product was manufactured in China (Made in China).

### REPRESENTATIVE

SINCLAIR Global Group s.r.o.  
Purkynova 45  
612 00 Brno  
Czech Republic

### TECHNICAL SUPPORT

SINCLAIR Global Group s.r.o.  
Purkynova 45  
612 00 Brno  
Czech Republic  
Tel.: +420 800 100 285 | Fax: +420 541 590 124  
[www.sinclair-solutions.com](http://www.sinclair-solutions.com) | [info@sinclair-solutions.com](mailto:info@sinclair-solutions.com)

