



**FULL DC INVERTER SYSTEMS**

**ENGINEERING DATA BOOK**

INDOOR UNITS SDV6-DHxxx

COMMERCIAL AIR CONDITIONERS SDV6



Original instructions

**IMPORTANT NOTE:**

Read this manual carefully before installing or operating your new air conditioning unit. Make sure to save this manual for future reference.

# High Static Pressure Duct

<b>1 Specifications .....</b>	<b>4</b>
<b>2 Dimensions.....</b>	<b>8</b>
<b>3 Unit Placement.....</b>	<b>8</b>
<b>4 Piping Diagrams .....</b>	<b>13</b>
<b>5 Wiring Diagrams.....</b>	<b>14</b>
<b>6 Capacity Tables.....</b>	<b>17</b>
<b>7 Electrical Characteristics .....</b>	<b>19</b>
<b>8 Sound Levels .....</b>	<b>20</b>
<b>9 Fan Performance .....</b>	<b>23</b>

# 1 Specifications

## SDV6-DH56 / SDV6-DH71 / SDV6-DH80/ SDV6-DH90

Table 1.1: SDV6-DH56(71,80,90) specifications

Model name			SDV6-DH56	SDV6-DH71	SDV6-DH80	SDV6-DH90
Power supply			1-phase, 220-240V, 50Hz			
Cooling <sup>1</sup>	Capacity	kW	5.6	7.1	8.0	9.0
		kBut/h	19.1	24.2	27.3	30.7
	Input	W	159	159	159	196
Heating <sup>2</sup>	Capacity	kW	6.3	8.0	9.0	10.0
		kBut/h	21.5	27.3	30.7	34.1
	Input	W	159	159	159	196
Fan motor	Type	DC				
	Number	1				
Coil	Number of rows		3	3	3	3
	Tube pitch × row pitch	mm	18×10.72			
	Fin spacing	mm	1.35	1.35	1.35	1.35
	Fin type		Hydrophilic aluminum			
	Tube OD and type	mm	Φ5 Inner groove			
	Dimensions (L×H×W)	mm	850×360×32.16	850×360×32.16	850×360×32.16	850×360×32.16
	Number of circuits		10	10	10	10
Airflow rate <sup>3</sup>	m <sup>3</sup> /h	1360/1281/1201/ 1122/1043/963/884	1360/1281/1201/ 1122/1043/963/884	1360/1281/1201/ 1122/1043/963/884	1500/1413/1325/ 1238/1150/1063/975	
External static pressure <sup>4</sup>	Pa	80 (0-250)				
Sound pressure level <sup>5</sup>	dB(A)	39/38/36/35/33/32/30	39/38/36/35/33/32/30	39/38/36/35/33/32/30	40/39/37/36/34/33/31	
Sound power level <sup>5</sup>	dB(A)	59/56/54/53/51/49/47	59/56/54/53/51/49/47	59/56/54/53/51/49/47	63/60/58/56/54/52/50	
Unit	Net dimensions <sup>6</sup> (W×H×D)	mm	1135×299×770			
	Packed dimensions (W×H×D)	mm	1215×359×890			
	Net/Gross weight	kg	35/38.5	35/38.5	35/38.5	35/38.5
Refrigerant type			R410A/R32			
Design pressure (H/L)		MPa	4.4/2.6			
Pipe connections	Liquid/Gas pipe	mm	Φ6.35/Φ12.7	Φ9.52/Φ15.9		
	Drain pipe	mm	OD Φ25			

Notes:

- Indoor temperature 27°C DB, 19°C WB; outdoor temperature 35°C DB; equivalent refrigerant piping length 7.5m with zero level difference.
- Indoor temperature 20°C DB; outdoor temperature 7°C DB, 6°C WB; equivalent refrigerant piping length 7.5m with zero level difference.
- Fan motor speed and air flow rate are from the highest speed to the lowest speed, total 7 rates for each model.
- Stable operation external static pressure range. (Note: setting external static pressure outside the unit's optimal static pressure range may lead to higher noise levels and lower airflow rate. For the optimal external static pressure range refer to the unit's installation manual.)
- Sound pressure level is from highest level to lowest level, total 7 levels for each model. Sound pressure level is measured 1.4m below the unit in an anechoic chamber.
- Unit body dimensions given are the largest external dimensions of the unit, including hanger attachments.

All specifications are measured at standard external static pressure

**SDV6-DH112 / SDV6-DH125/ SDV6-DH140 / SDV6-DH160**

Table 1.2: SDV6-DH112(125,140,160) specifications

Model name			SDV6-DH112	SDV6-DH125	SDV6-DH140	SDV6-DH160
Power supply			1-phase, 220-240V, 50Hz			
Cooling <sup>1</sup>	Capacity	kW	11.2	12.5	14.0	16.0
		kBut/h	38.2	42.7	47.8	54.6
	Input	W	248	252	284	339
Heating <sup>2</sup>	Capacity	kW	12.5	14.0	16.0	18.0
		kBut/h	42.7	47.8	54.6	61.4
	Input	W	248	252	284	339
Fan motor	Type		DC			
	Number		1			
Coil	Number of rows		2	3	3	3
	Tube pitch × row pitch	mm	18×10.72			
	Fin spacing	mm	1.35	1.35	1.35	1.35
	Fin type		Hydrophilic aluminum			
	Tube OD and type	mm	Φ5 Inner groove			
	Dimensions (L×H ×W)	mm	1200×360×21.44	1200×360×32.16	1200×360×32.16	1200×360×32.16
	Number of circuits		10	10	10	10
Airflow rate <sup>3</sup>	m <sup>3</sup> /h	2140/2015/1890/1766/ 1641/1516/1391	2150/2025/1899/1774/ 1649/1523/1398	2400/2260/2120/1980/ 1840/1700/1560	2600/2448/2297/2145/ 1993/1842/1690	
External static pressure <sup>4</sup>	Pa	80 (0-250)	100 (0-250)			
Sound pressure level <sup>5</sup>	dB(A)	41/40/38/37/35/34/32	41/40/39/37/36/35/33	43/42/40/39/37/36/34	44/43/41/40/38/37/35	
Sound power level <sup>5</sup>	dB(A)	63/61/59/57/56/54/52	66/64/62/60/58/56/54	67/64/62/60/58/57/55	68/66/64/62/60/59/57	
Unit	Net dimensions <sup>6</sup> (W×H×D)	mm	1485×299×770			
	Packed dimensions (W×H×D)	mm	1565×359×890			
	Net/Gross weight	kg	44.5/48.5	46.5/50.5	46.5/50.5	46.5/50.5
Refrigerant type			R410A/R32			
Design pressure (H/L)	MPa	4.4/2.6				
Pipe connections	Liquid/Gas pipe	mm	Φ9.52/Φ15.9			
	Drain pipe	mm	OD Φ25			

Notes:

- Indoor temperature 27°C DB, 19°C WB; outdoor temperature 35°C DB; equivalent refrigerant piping length 7.5m with zero level difference.
  - Indoor temperature 20°C DB; outdoor temperature 7°C DB, 6°C WB; equivalent refrigerant piping length 7.5m with zero level difference.
  - Fan motor speed and air flow rate are from the highest speed to the lowest speed, total 7 rates for each model.
  - Stable operation external static pressure range. (Note: setting external static pressure outside the unit's optimal static pressure range may lead to higher noise levels and lower airflow rate. For the optimal external static pressure range refer to the unit's installation manual.)
  - Sound pressure level is from highest level to lowest level, total 7 levels for each model. Sound pressure level is measured 1.4m below the unit in an anechoic chamber.
  - Unit body dimensions given are the largest external dimensions of the unit, including hanger attachments.
- All specifications are measured at standard external static pressure

**SDV6-DH200 / SDV6-DH224 / SDV6-DH252/ SDV6-DH280**

Table 1.3: SDV6-DH200(224,252,280) specifications

Model name			SDV6-DH200	SDV6-DH224	SDV6-DH252	SDV6-DH280
Power supply			1-phase, 220-240V, 50Hz			
Cooling <sup>1</sup>	Capacity	kW	20.0	22.4	25.2	28.0
		kBut/h	68.3	76.5	86.0	95.6
	Input	W	780	780	780	780
Heating <sup>2</sup>	Capacity	kW	22.5	25.0	26.0	31.5
		kBut/h	76.8	85.3	88.7	107.5
	Input	W	780	780	780	780
Fan motor	Type	DC				
	Number	1				
Coil	Number of rows		3	3	3	3
	Tube pitch × row pitch	mm	21×13.37			
	Fin spacing	mm	1.5	1.5	1.5	1.5
	Fin type		Hydrophilic aluminum			
	Tube OD and type	mm	Φ7 Inner groove			
	Dimensions (L×H ×W)	mm	1050×588×40.1	1050×588×40.1	1050×588×40.1	1050×588×40.1
	Number of circuits		14	14	14	14
Airflow rate <sup>3</sup>		m <sup>3</sup> /h	4700/4387/4073/3760/ 3447/3133/2820	4700/4387/4073/3760/ 3447/3133/2820	4700/4387/4073/3760/ 3447/3133/2820	4700/4387/4073/3760/ 3447/3133/2820
External static pressure <sup>4</sup>		Pa	200(0-400)			
Sound pressure level <sup>5</sup>		dB(A)	51/50/48/46/44/43/42	51/50/48/46/44/43/42	51/50/48/46/44/43/42	51/50/48/46/44/43/42
Sound power level <sup>5</sup>		dB(A)	74/72/70/68/66/64/62	74/72/70/68/66/64/62	74/72/70/68/66/64/62	74/72/70/68/66/64/62
Unit	Net dimensions <sup>6</sup> (W×H×D)	mm	1310×580×1050			
	Packed dimensions (W×H×D)	mm	1530×730×1060			
	Net/Gross weight	kg	125/150	125/150	125/150	125/150
Refrigerant type			R410A/R32			
Design pressure (H/L)		MPa	4.4/2.6			
Pipe connections	Liquid/Gas pipe	mm	Φ9.52/Φ19.1		Φ12.7/Φ22.2	
	Drain pipe	mm	OD Φ32			

Notes:

- Indoor temperature 27°C DB, 19°C WB; outdoor temperature 35°C DB; equivalent refrigerant piping length 7.5m with zero level difference.
  - Indoor temperature 20°C DB; outdoor temperature 7°C DB, 6°C WB; equivalent refrigerant piping length 7.5m with zero level difference.
  - Fan motor speed and air flow rate are from the highest speed to the lowest speed, total 7 rates for each model.
  - Stable operation external static pressure range. (Note: setting external static pressure outside the unit's optimal static pressure range may lead to higher noise levels and lower airflow rate. For the optimal external static pressure range refer to the unit's installation manual.)
  - Sound pressure level is from highest level to lowest level, total 7 levels for each model. Sound pressure level is measured 1.4m below the unit in an anechoic chamber.
  - Unit body dimensions given are the largest external dimensions of the unit, including hanger attachments.
- All specifications are measured at standard external static pressure

**SDV6-DH335 / SDV6-DH400/ SDV6-DH450 / SDV6-DH560**

Table 1.4: SDV6-DH335 (400,450,560) specifications

Model name			SDV6-DH335	SDV6-DH400	SDV6-DH450	SDV6-DH560
Power supply			1-phase, 220-240V, 50Hz			
Cooling <sup>1</sup>	Capacity	kW	33.5	40.0	45.0	56.0
		kBut/h	114.3	136.5	153.6	191.1
	Input	W	810	1850	1850	2030
Heating <sup>2</sup>	Capacity	kW	38.0	45.0	56.0	63.0
		kBut/h	129.7	153.6	191.1	215.0
	Input	W	810	1850	1850	2030
Fan motor	Type	DC				
	Number	1				
Coil	Number of rows		4	3	3	4
	Tube pitch × row pitch	mm	21×13.37			
	Fin spacing	mm	1.5	1.5	1.5	1.5
	Fin type		Hydrophilic aluminum			
	Tube OD and type	mm	Φ7 Inner groove			
	Dimensions (L×H ×W)	mm	1050×588×42.7	1600×588×40.1	1600×588×40.1	1600×588×42.7
	Number of circuits		14	14	14	14
Airflow rate <sup>3</sup>	m <sup>3</sup> /h	4700/4387/4073/3760/ 3447/3133/2820	7500/7000/6500/6000/ 5500/5000/4500	7500/7000/6500/6000/ 5500/5000/4500	8400/7840/7280/6720/ 6160/5600/5040	
External static pressure <sup>4</sup>	Pa	200 (0-400)	300 (0-400)			
Sound pressure level <sup>5</sup>	dB(A)	52/51/49/48/46/44/43	58/56/54/52/50/49/48	58/56/54/52/50/49/48	59/58/56/54/53/51/49	
Sound power level <sup>5</sup>	dB(A)	74/72/70/68/66/63/61	79/78/76/74/72/70/67	79/78/76/74/72/70/67	81/80/77/75/73/71/69	
Unit	Net dimensions <sup>6</sup> (W×H×D)	mm	1310×580×1050	1860×580×1050		
	Packed dimensions (W×H×D)	mm	1530×730×1060	2080×730×1060		
	Net/Gross weight	kg	128/153	166/204	166/204	170/208
Refrigerant type			R410A/R32			
Design pressure (H/L)		MPa	4.4/2.6			
Pipe connections	Liquid/Gas pipe	mm	Φ12.7/Φ25.4		Φ15.9/Φ28.6	
	Drain pipe	mm	OD Φ32			

Notes:

- Indoor temperature 27°C DB, 19°C WB; outdoor temperature 35°C DB; equivalent refrigerant piping length 7.5m with zero level difference.
  - Indoor temperature 20°C DB; outdoor temperature 7°C DB, 6°C WB; equivalent refrigerant piping length 7.5m with zero level difference.
  - Fan motor speed and air flow rate are from the highest speed to the lowest speed, total 7 rates for each model.
  - Stable operation external static pressure range. (Note: setting external static pressure outside the unit's optimal static pressure range may lead to higher noise levels and lower airflow rate. For the optimal external static pressure range refer to the unit's installation manual.)
  - Sound pressure level is from highest level to lowest level, total 7 levels for each model. Sound pressure level is measured 1.4m below the unit in an anechoic chamber.
  - Unit body dimensions given are the largest external dimensions of the unit, including hanger attachments.
- All specifications are measured at standard external static pressure

## 2 Dimensions

### 2.1 Unit Dimensions

SDV6\_DH56 / SDV6\_DH71 / SDV6\_DH80/

SDV6-DH90 / SDV6-DH112 / SDV6-DH125/

SDV6-DH140 /SDV6-DH160

Figure 2.1: SDV6-DH56(71,80,90,112,125,140,160) dimensions (unit: mm)

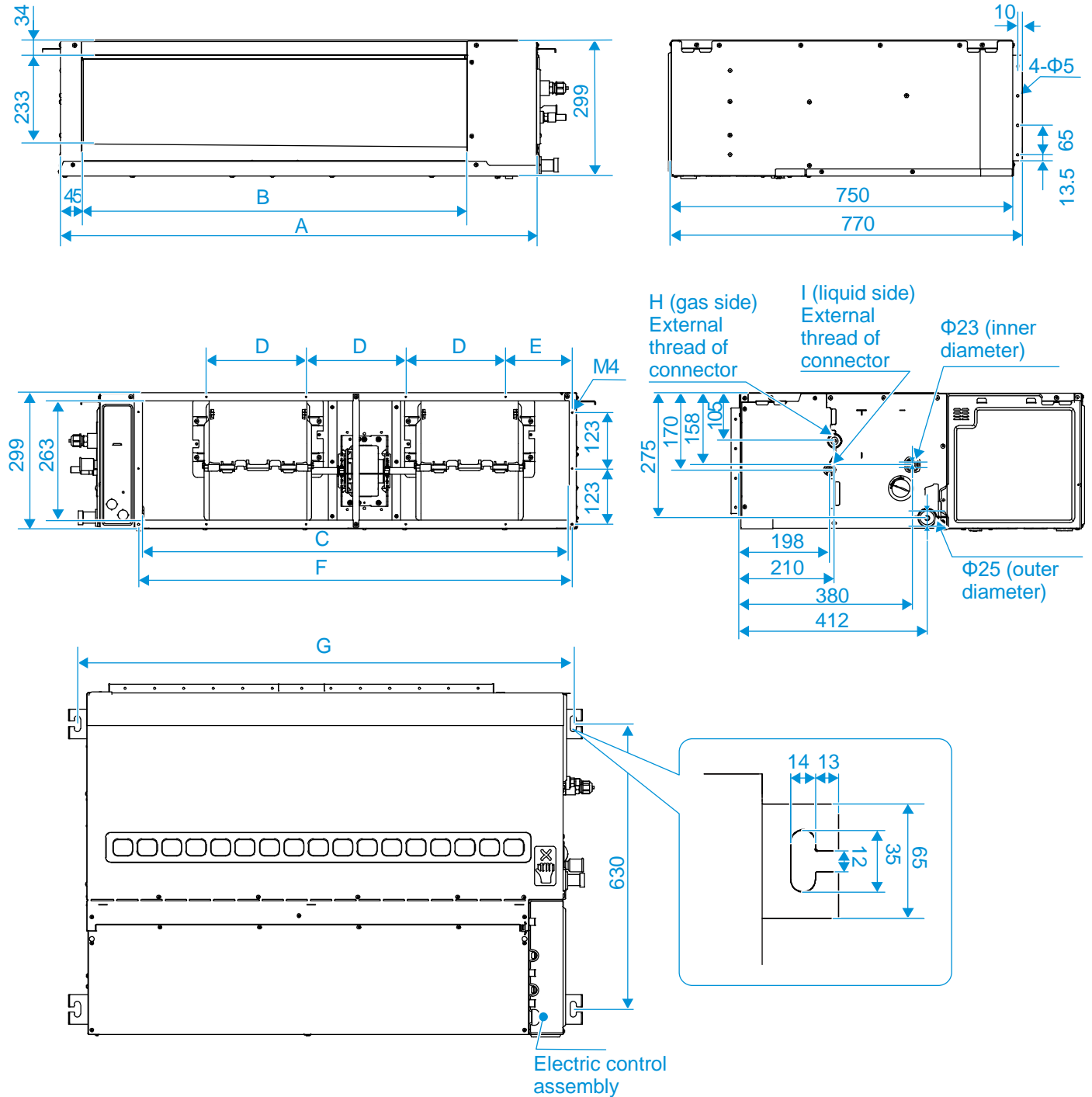

Model (kW)	A	B	C	D	E	F	G	H	I
kW≤5.6	1050	850	940	220	146	956	1095	3/4-16 UNF	7/16-20 UNF
5.6<kW≤9.0	1050	850	940	220	146	956	1095	7/8-14 UNF	5/8-18 UNF
9.0<kW≤16.0	1400	1200	1290	220	213	1306	1445	7/8-14 UNF	5/8-18 UNF

SDV6-DH200 / SDV6-DH224 / SDV6-DH252/ SDV6-DH280/ SDV6-DH335

Figure 2.2: SDV6-DH(224,252,280,335) dimensions (unit: mm)

Appearance and dimensions of the air inlets, piping, drain pipes, power cable hole and communication wire hole:

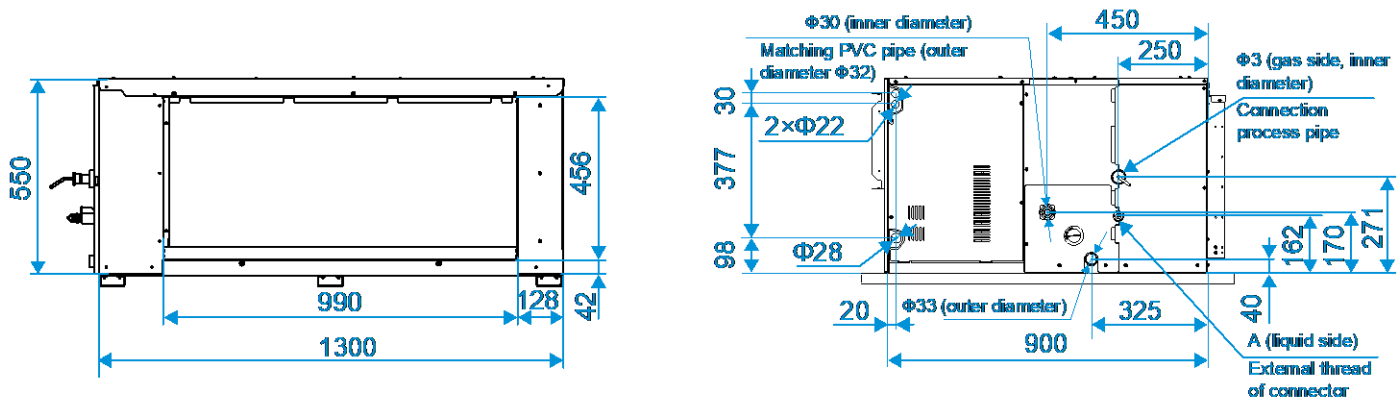

Dimensions of the air outlets:

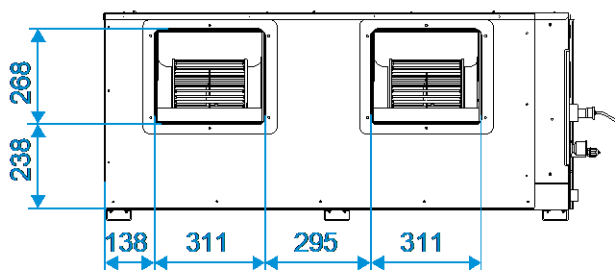

Dimensions of the air duct installation hole after the air outlet flange is removed:

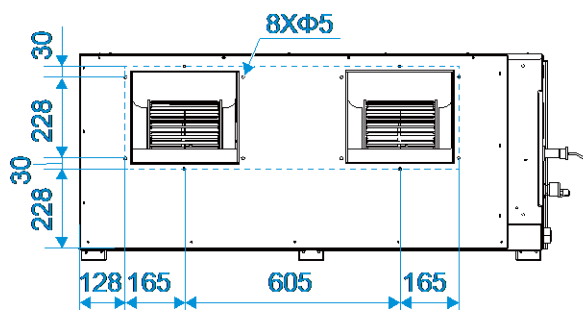

Dimensions of lugs and the screw hole of air outlet/inlet flange:

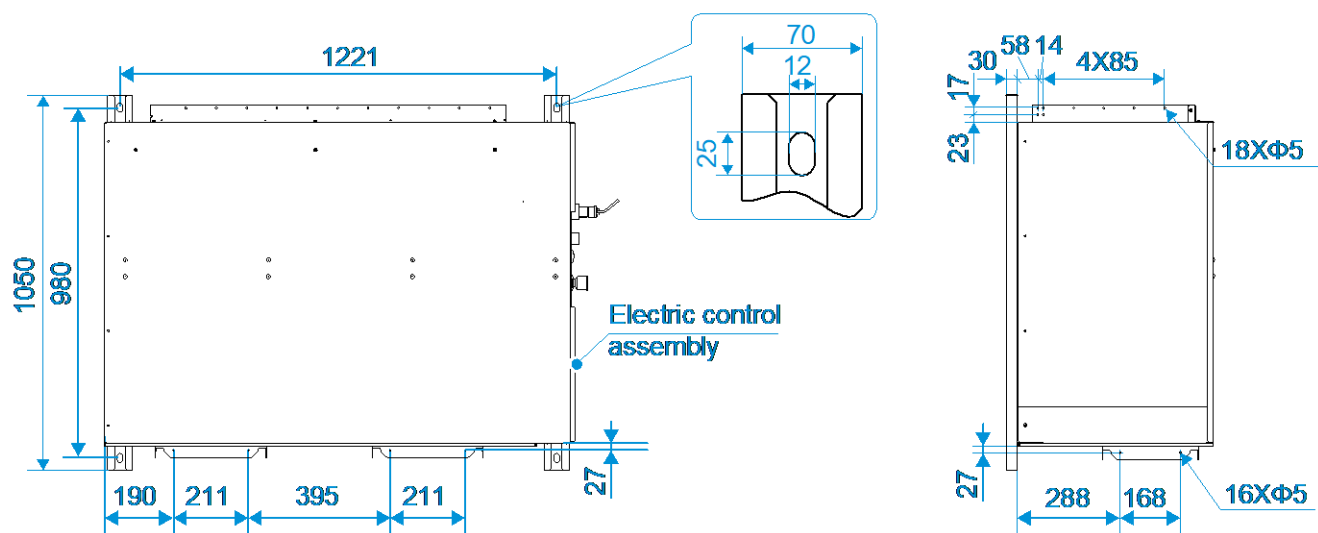

Capacity (kW)	A
$20.0 \leq kW \leq 22.4$	5/8-18 UNF
$22.4 < kW \leq 33.5$	3/4-16 UNF

SDV6-DH400 / SDV6-DH450 / SDV6-DH560

Figure 2.3: SDV6-DH400(450,560) dimensions (unit: mm)

Appearance and dimensions of the air inlets, piping, drain pipes, power cable hole and communication wire hole:

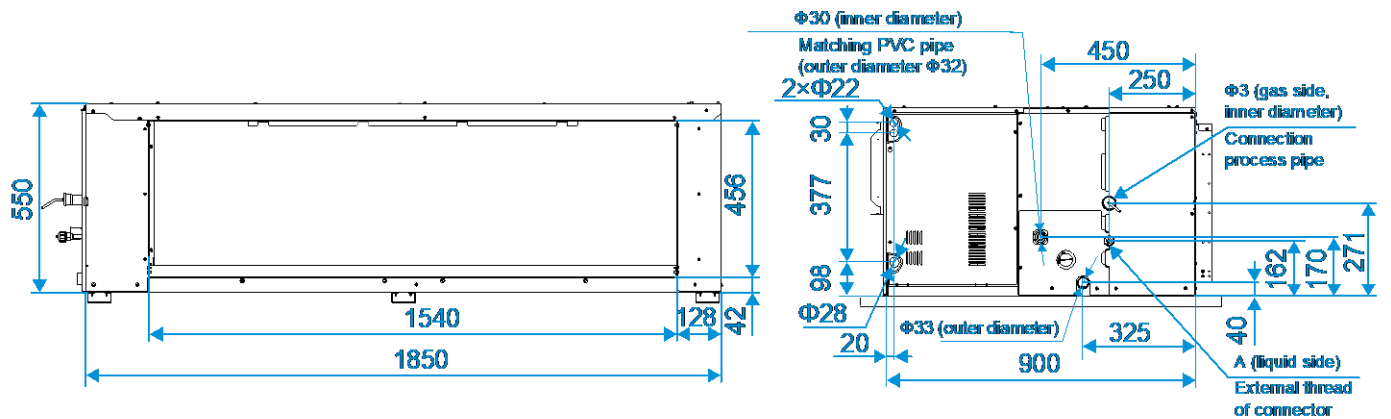

Dimensions of the air outlets:

Dimensions of the air duct installation hole after the air outlet flange is removed:

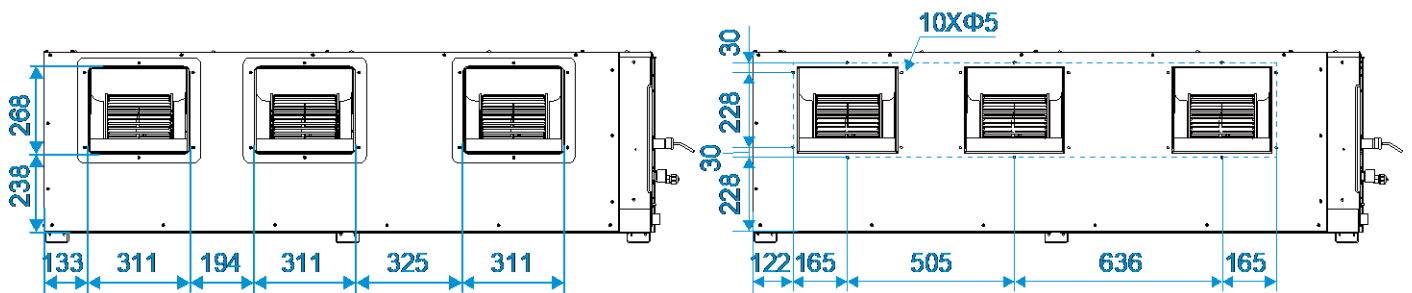

Dimensions of lugs and the screw hole of air outlet/inlet flange:

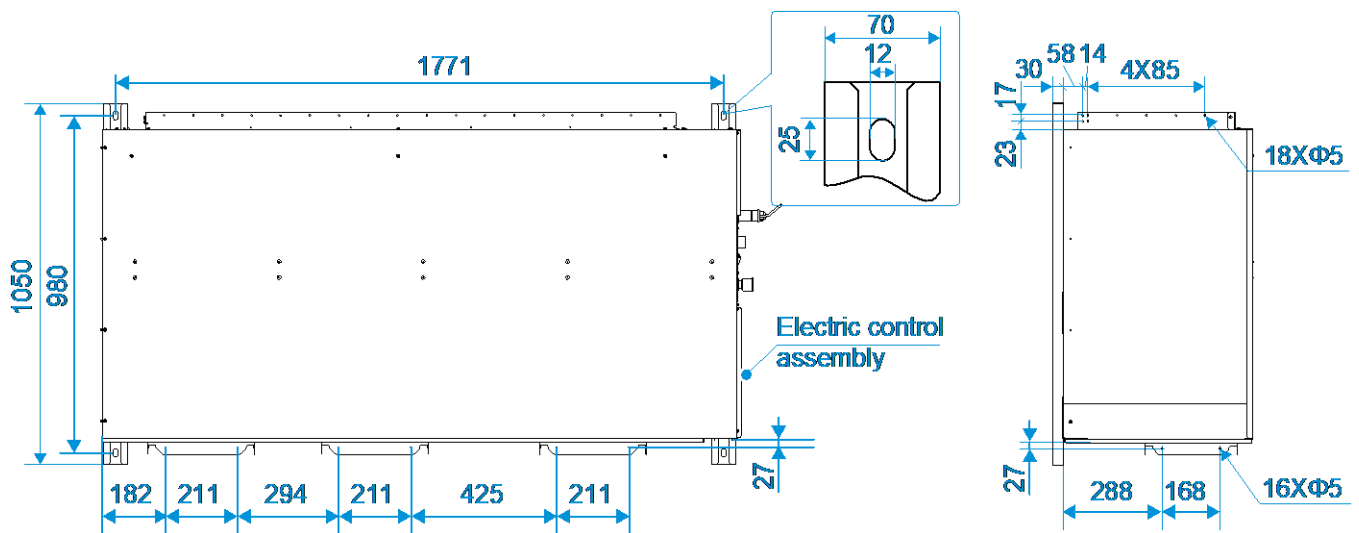

Capacity (kW)	A
33.5 < kW ≤ 40.0	3/4-16 UNF
40.0 < kW ≤ 56.0	7/8-14 UNF

### 3 Unit Placement

#### 3.1 Placement Considerations

Unit placement should take account of the following considerations:

- Units should not be installed in the following locations:
  - Where exposure to direct radiation from a high-temperature heat source or to interference from a source of electromagnetic radiation may occur.
  - Where dust or dirt may affect heat exchangers.
  - Where exposure to oil or to corrosive or harmful gases, such as acidic or alkaline gases, may occur.
  - Where exposure to salinity may occur, such as seaside locations.
  - Where highly flammable materials are present.
  - Where exposure to oily air may occur, such as a kitchen.
  - Where exposure to very high humidity may occur, such as a laundry.
- Units should be installed in positions where:
  - The ceiling is horizontal and is able to bear the unit's weight.
  - There are no obstructions that could impede the airflow into and out of the unit.
  - The airflow out of the unit can reach throughout the room.
  - There is sufficient space for access during installation, servicing and maintenance.
  - The refrigerant piping and drain piping can be easily connected to the refrigerant piping and drain piping systems.
  - Short-circuit ventilation (where outlet air returns quickly to a unit's air inlet) will not occur.

#### 3.2 Space Requirements

SDV6-DH56 / SDV6-DH71 / SDV6-DH80/ SDV6-DH90 / SDV6-DH112 / SDV6-DH125/ SDV6-DH140 /SDV6-DH160

Figure 3.1: High Static Pressure Duct space requirements (unit: mm)

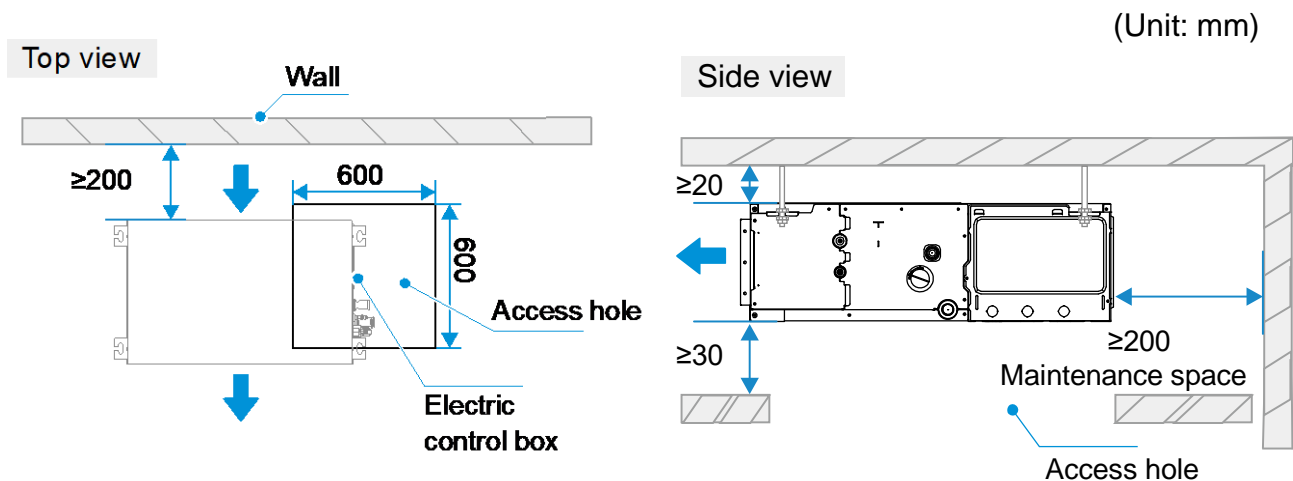

SDV6-DH200 / SDV6-DH224 / SDV6-DH252/  
 SDV6-DH280 / SDV6-DH335 / SDV6-DH400/ SDV6-DH450  
 /SDV6-DH560

Figure 3.1: High Static Pressure Duct space requirements (unit: mm)

(Unit: mm)

Bottom view

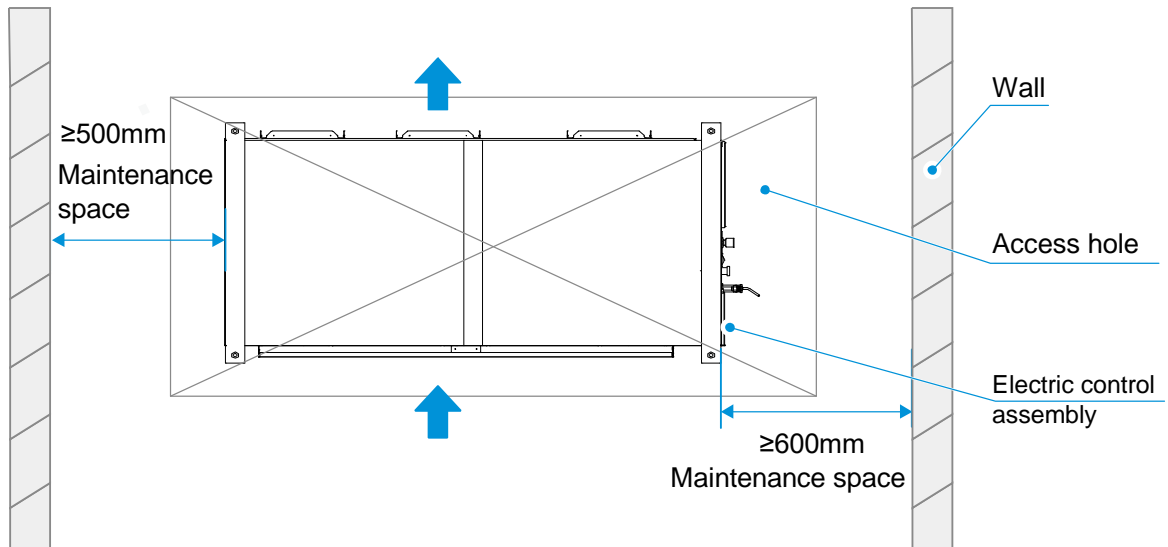

Side view

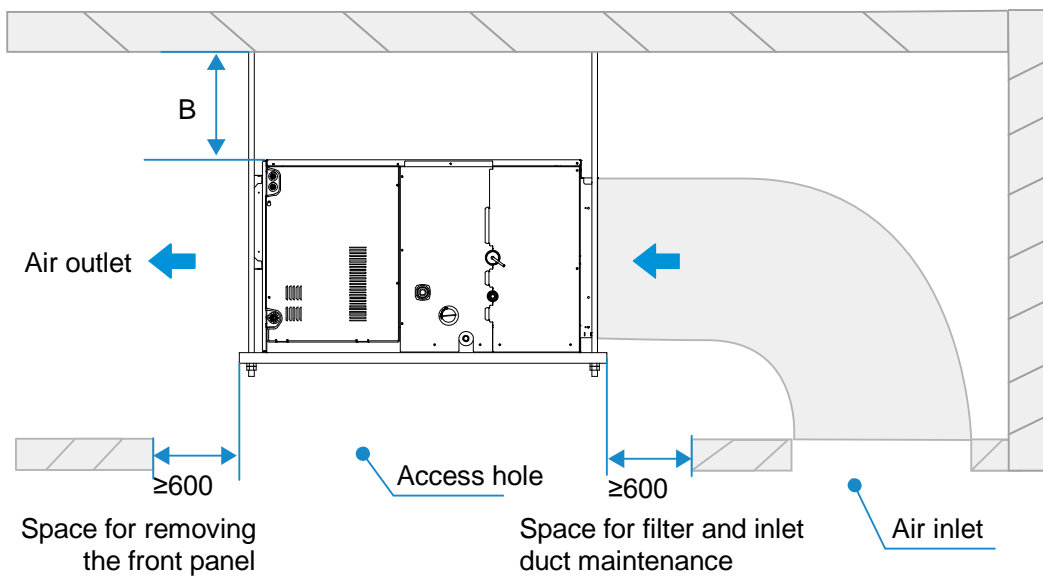

Notes for installers and service engineers

1. The distance between the indoor unit and the roof (B) shall be greater than 50mm to install the air duct.
2. The motor and fan can be maintained from the indoor unit top or the air outlet. If maintenance is performed from the indoor unit top, the distance between the indoor unit and the roof must be larger than 600mm. If maintenance is performed from the air outlet, the distance between the indoor unit and the roof must be larger than 50mm, with a minimum distance of 600mm allowed for removing the front panel.

## 4 Piping Diagrams

Figure 4.1: Piping diagram

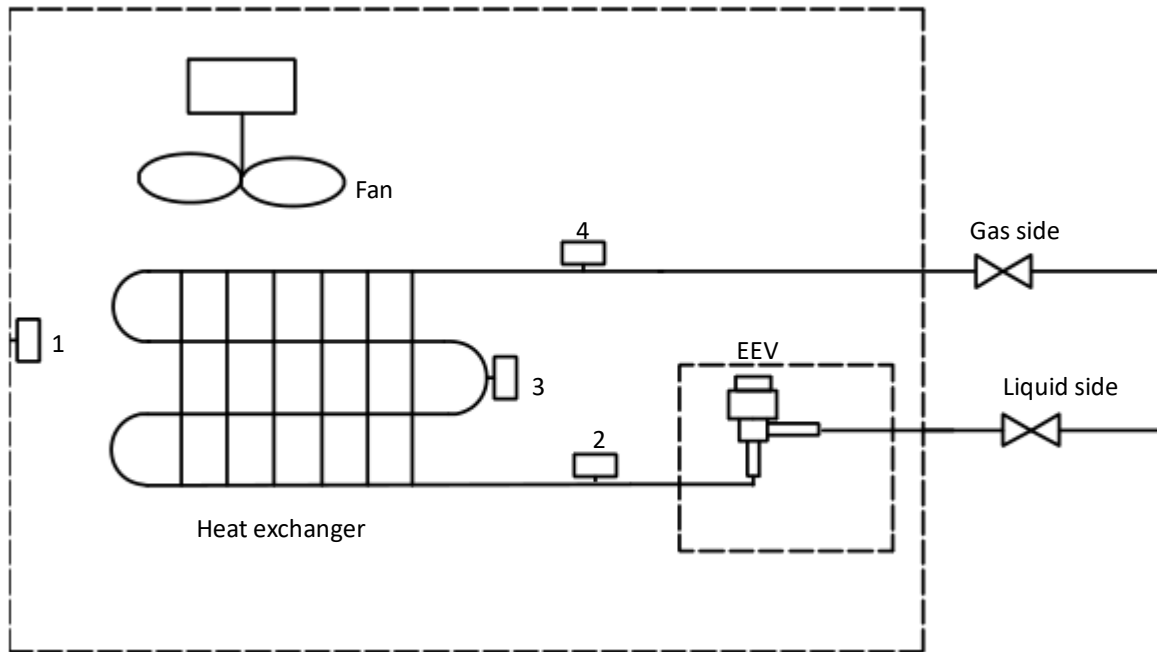

Legend		
1	T1	Inlet Air Temp. Sensor
2	T2A	Liquid Pipe Temp. Sensor
3	T2	Middle Pipe Temp. Sensor
4	T2B	Gas Pipe Temp. Sensor
5	EEV	Electronic expansion valve
6	FAN	Fan motor

# 5 Wiring Diagrams

SDV6-DH56 / SDV6-DH71 / SDV6-DH80/  
 SDV6-DH90 / SDV6-DH112 / SDV6-DH125 /  
 SDV6-DH140 /SDV6-DH160

Figure 5.1: SDV6-56(71,80,90,112,125,140,160) Duct wiring diagram

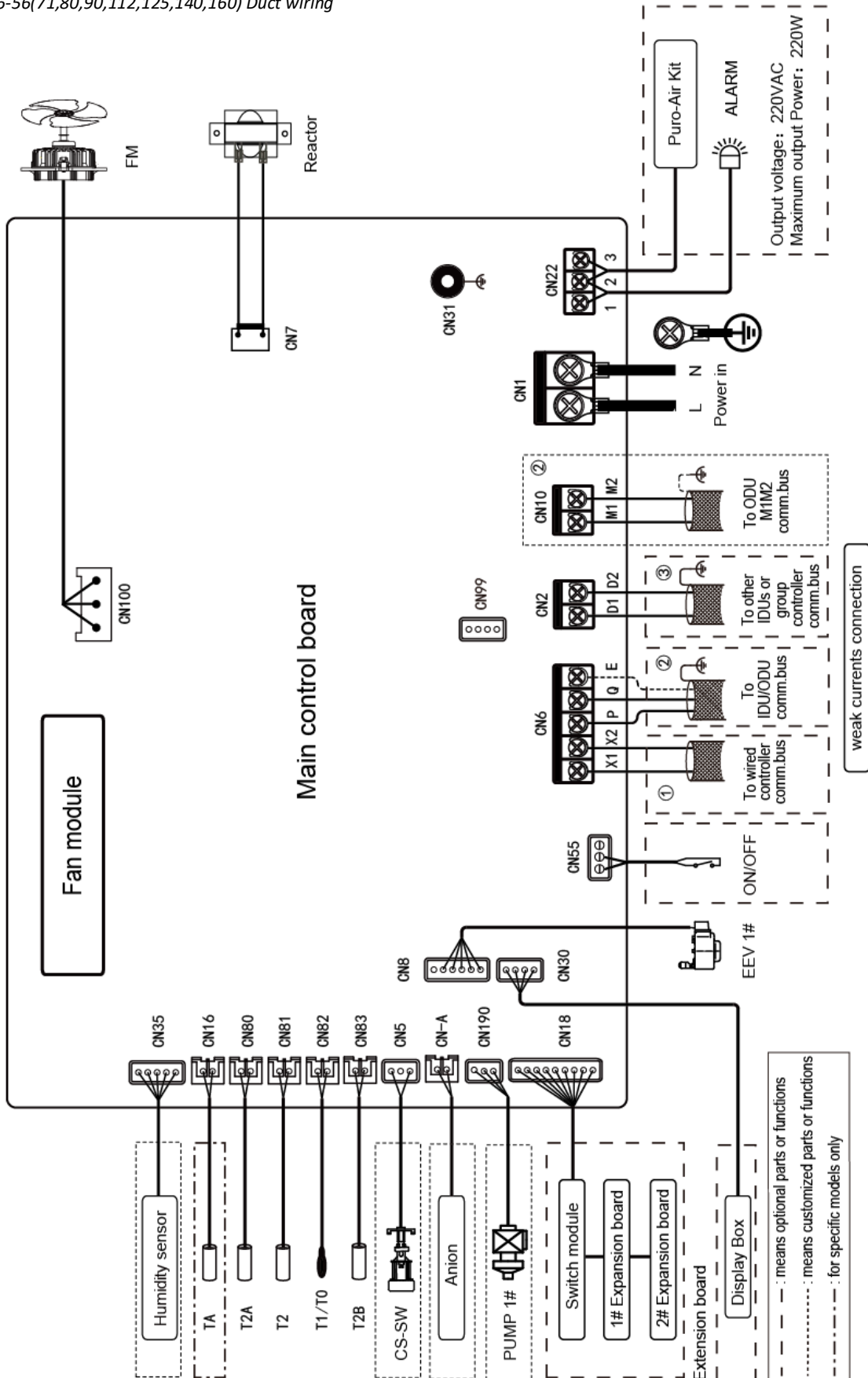

SDV6-DH200 / SDV6-DH224 / SDV6-DH252/  
 SDV6-DH280SDV6-DH335 / SDV6-DH400/ SDV6-DH450 /  
 SDV6-DH560

Figure 5.2: SDV6-DH200(224,252,280,335,400,450,560) Duct wiring diagram

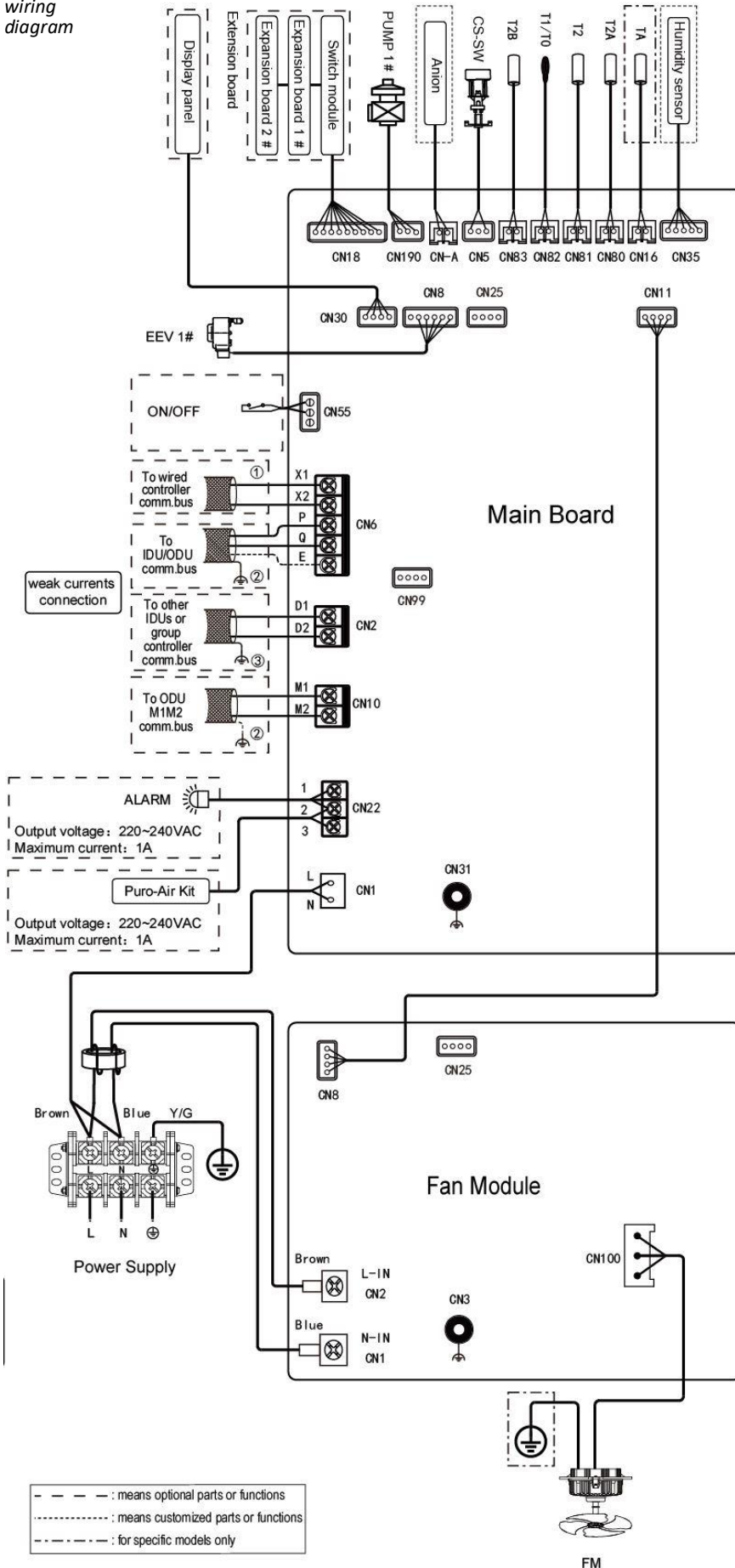

Legend			
Code	Name		
XS XP	connectors		
TA	Steam pipe temperature sensor*	T1	Inlet Air Temp. Sensor
CS-SW	Water level switch	T2B	Gas Pipe Temp. Sensor
EEV	Electronic expansion valve	T0	Fresh air inlet temperature sensor*
Anion	Sterilization module	ALARM	Alarm output
T2A	Liquid Pipe Temp. Sensor	FM	DC Fan motor
T2	Middle Pipe Temp. Sensor	ON/OFF	Remote on/off

\* Indicates that this sensor is only available for Fresh Air Processing Unit

## Notes for installers and service engineers

### Caution

- All installation, servicing and maintenance must be carried out by competent and suitably qualified, certified and accredited professionals and in accordance with all applicable legislation.
- Units should be grounded in accordance with all applicable legislation. Metal and other conductive components should be insulated in accordance with all applicable legislation.
- Power supply wiring should be securely fastened at the power supply terminals – loose power supply wiring would represent a fire risk.
- After installation, servicing or maintenance, the electric control box cover should be closed. Failing to close the electric control box cover risks fire or electric shock.
- The dotted lines indicate the field wiring or optional function.
- X1X2 communication ports can be connected to the wired controller.
- PQ and M1M2 communication ports both are used for indoor and outdoor communication, and only one of them can be used at a time. Meanwhile, be sure to connect the same communication ports (PQ to PQ; M1M2 to M1M2) in case of damage of the main control board.
- D1D2 communication ports are used for group control communication. When connecting the group controller, the D1D2 port of the indoor units that are to be group controlled must be connected in daisy chain, and the group controller must be connected to the X1X2 port of one of the indoor units in the group control, and set to

## 6 Capacity Tables

### 6.1 Cooling Capacity Table

Table 6.1: High Static Pressure Duct cooling capacity

Model	Indoor air temperature (°C WB/DB)													
	14/20		16/23		18/26		19/27		20/28		22/30		24/32	
	TC	SC	TC	SC	TC	SC	TC	SC	TC	SC	TC	SC	TC	SC
SDV6-DH56	5.0	4.8	5.3	4.8	5.6	4.9	5.6	4.7	5.7	4.6	5.8	4.3	6.0	4.1
SDV6-DH71	6.3	6.0	6.7	6.1	7.0	6.1	7.1	6.0	7.2	5.8	7.4	5.5	7.6	5.2
SDV6-DH80	7.1	6.8	7.6	6.9	7.9	6.9	8.0	6.7	8.1	6.5	8.3	6.1	8.5	5.8
SDV6-DH90	8.0	7.5	8.5	7.6	8.9	7.7	9.0	7.5	9.1	7.2	9.4	6.9	9.6	6.6
SDV6-DH112	9.9	9.3	10.6	9.5	11.1	9.6	11.2	9.3	11.3	9.0	11.6	8.5	11.9	8.1
SDV6-DH125	11.0	10.1	11.8	10.4	12.4	10.5	12.5	10.2	12.6	9.9	12.9	9.4	13.3	9.0
SDV6-DH140	12.4	11.3	13.2	11.6	13.8	11.7	14.0	11.4	14.2	11.1	14.5	10.5	14.9	10.1
SDV6-DH160	14.2	13.1	15.1	13.3	15.8	13.5	16.0	13.1	16.2	12.7	16.6	12.1	17.0	11.7
SDV6-DH200	17.7	16.1	18.9	16.5	19.8	16.8	20.0	16.3	20.2	15.8	20.8	15.1	21.2	14.4
SDV6-DH224	19.8	18.0	21.1	18.5	22.1	18.7	22.4	18.3	22.6	17.7	23.2	16.8	23.7	16.1
SDV6-DH252	22.3	20.3	23.8	20.8	24.9	21.1	25.2	20.5	25.5	19.9	26.1	18.9	26.7	18.1
SDV6-DH280	24.8	22.6	26.4	23.1	27.6	23.4	28.0	22.8	28.3	22.1	29.0	21.0	29.7	20.1
SDV6-DH335	29.6	26.9	31.6	27.6	33.1	28.0	33.5	27.3	33.8	26.4	34.7	25.1	35.5	24.1
SDV6-DH400	35.4	32.1	37.7	32.9	39.5	33.4	40.0	32.5	40.4	31.5	41.5	30.0	42.4	28.7
SDV6-DH450	39.8	36.1	42.4	37.0	44.4	37.5	45.0	36.6	45.4	35.4	46.6	33.7	47.6	32.2
SDV6-DH560	49.5	45.5	52.8	46.5	55.2	47.0	56.0	45.8	56.5	44.3	58.0	42.1	59.3	40.8

Abbreviations:

TC: Total capacity (kW)

SC: Sensible capacity (kW)

Notes:

1. Shaded cells indicate rating condition

## 6.2 Heating Capacity Table

Table 7.2: High Static Pressure Duct heating capacity

Model	Indoor air temperature (°C DB)					
	16	18	20	21	22	24
	SHC	SHC	SHC	SHC	SHC	SHC
SDV6-DH56	6.7	6.6	6.3	6.1	5.9	5.5
SDV6-DH71	8.5	8.4	8.0	7.8	7.5	7.0
SDV6-DH80	9.5	9.5	9.0	8.7	8.5	7.8
SDV6-DH90	10.6	10.5	10.0	9.7	9.4	8.8
SDV6-DH112	13.3	13.1	12.5	12.1	11.8	10.9
SDV6-DH125	14.8	14.7	14.0	13.6	13.2	12.2
SDV6-DH140	17.0	16.8	16.0	15.5	15.0	13.9
SDV6-DH160	19.1	18.9	18.0	17.5	16.9	15.7
SDV6-DH200	23.9	23.6	22.5	21.8	21.2	19.6
SDV6-DH224	26.5	26.3	25.0	24.3	23.5	21.8
SDV6-DH252	27.6	27.3	26.0	25.2	24.4	22.6
SDV6-DH280	33.4	33.1	31.5	30.6	29.6	27.4
SDV6-DH335	40.3	39.9	38.0	36.9	35.7	33.1
SDV6-DH400	47.7	47.3	45.0	43.7	42.3	39.2
SDV6-DH450	59.4	58.8	56.0	54.3	52.6	48.7
SDV6-DH560	66.8	66.2	63.0	61.1	59.2	54.8

Abbreviations:

SHC: Sensible Heat Capacity (kW)

Notes:

1. Shaded cells indicate rating condition

## 7 Electrical Characteristics

Table 8.1: High Static Pressure Duct electrical characteristics

Model	Power supply						Indoor fan motors	
	Hz	Volts (V)	Min. volts	Max. volts	MCA (A)	MFA (A)	Power input (W)	FLA (A)
SDV6-DH56	50/60	220-240	198	264	2.33	15	240	1.86
SDV6-DH71	50/60	220-240	198	264	2.33		240	1.86
SDV6-DH80	50/60	220-240	198	264	2.33		240	1.86
SDV6-DH90	50/60	220-240	198	264	2.46		240	1.97
SDV6-DH112	50/60	220-240	198	264	3.34		560	2.67
SDV6-DH125	50/60	220-240	198	264	3.38		560	2.70
SDV6-DH140	50/60	220-240	198	264	3.75		560	3.00
SDV6-DH160	50/60	220-240	198	264	4.13		560	3.30
SDV6-DH200	50/60	220-240	198	264	8.19	30	920	6.55
SDV6-DH224	50/60	220-240	198	264	8.19		920	6.55
SDV6-DH252	50/60	220-240	198	264	8.19		920	6.55
SDV6-DH280	50/60	220-240	198	264	8.19		920	6.55
SDV6-DH335	50/60	220-240	198	264	8.31		920	6.65
SDV6-DH400	50/60	220-240	198	264	12.98		2300	10.38
SDV6-DH450	50/60	220-240	198	264	12.98		2300	10.38
SDV6-DH560	50/60	220-240	198	264	15.49		2300	12.39

**Abbreviations:**

MCA: Min. Circuit Amps. (A), which is used to select the minimum circuit size to ensure safe operation over a long period of time.

MFA: Max. Fuse Amps. (A), which is used to select the circuit breaker.

FLA: Full Load Amps. (A), which is the full load current of the indoor fan motor (reliable operation at the fastest speed setting).

Indoor fan motors power input: full load power input of the indoor fan motor (reliable operation at the fastest speed setting).

## 8 Sound Levels

### 8.1 Overall

Table 8.1: High Static Pressure Duct sound pressure levels<sup>1</sup>

Model name	Sound pressure levels dB(A)						
	SSH	SH	H	M	L	SL	SSL
SDV6-DH56	39	38	36	35	33	32	30
SDV6-DH71	39	38	36	35	33	32	30
SDV6-DH80	39	38	36	35	33	32	30
SDV6-DH90	40	39	37	36	34	33	31
SDV6-DH112	41	40	38	37	35	34	32
SDV6-DH125	41	40	39	37	36	35	33
SDV6-DH140	43	42	40	39	37	36	34
SDV6-DH160	44	43	41	40	38	37	35
SDV6-DH200	51	50	48	46	44	43	42
SDV6-DH224	51	50	48	46	44	43	42
SDV6-DH252	51	50	48	46	44	43	42
SDV6-DH280	51	50	48	46	44	43	42
SDV6-DH335	52	51	49	48	46	44	43
SDV6-DH400	58	56	54	52	50	49	48
SDV6-DH450	58	56	54	52	50	49	48
SDV6-DH560	59	58	56	54	53	51	49

Notes:

1. Sound pressure levels are measured 1.4m below the unit in an anechoic chamber. During in-situ operation, sound pressure levels may be higher as a result of ambient noise.

Figure 8.1: High Static Pressure Duct sound pressure level measurement

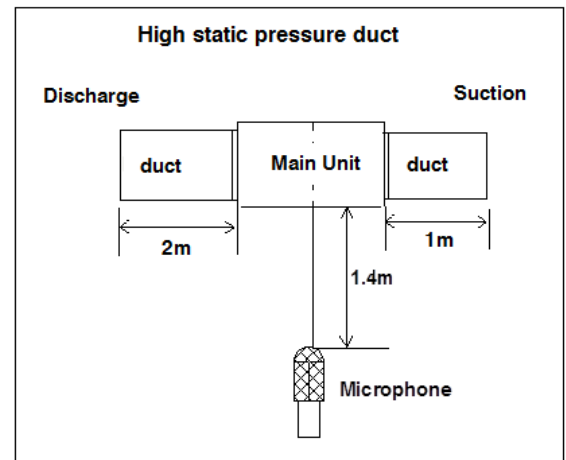

### 8.2 Octave Band Levels

Figure 8.2: SDV6-DH56(71,80) octave band levels

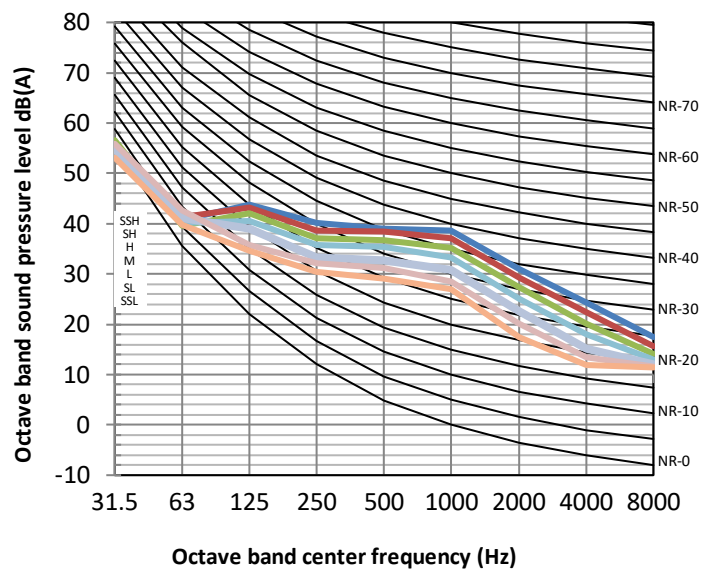

Figure 8.3: SDV6-DH90 octave band levels

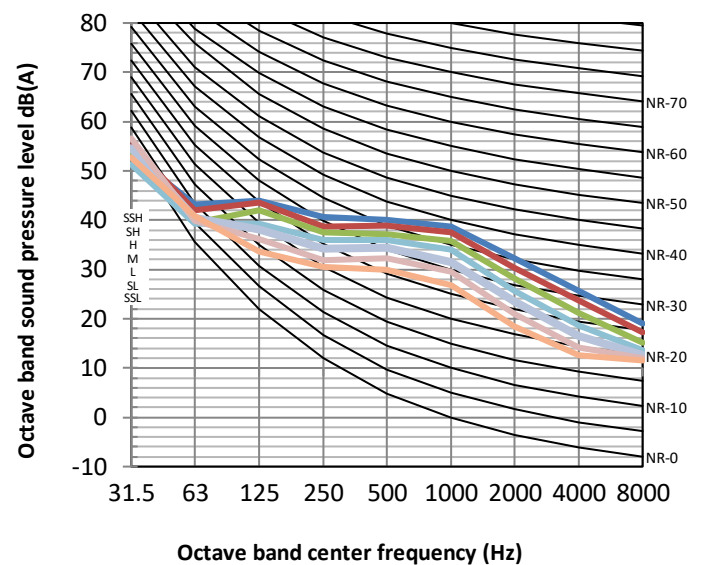

Figure 8.4: SDV6-DH112 octave band levels

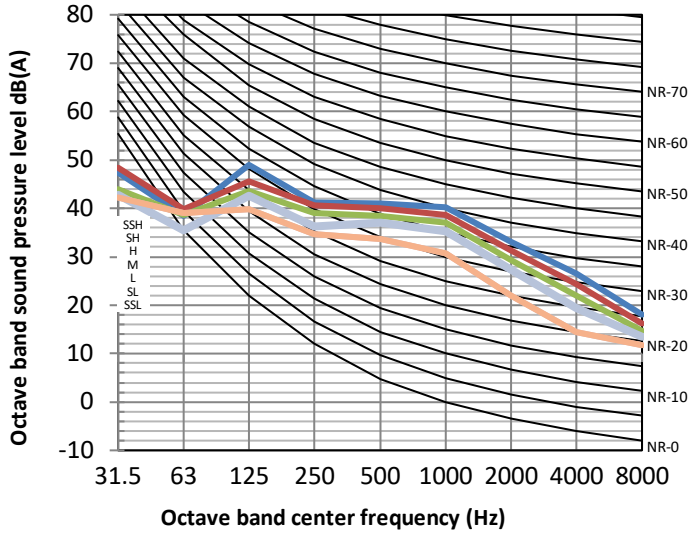

Figure 8.5: SDV6-DH125 octave band levels

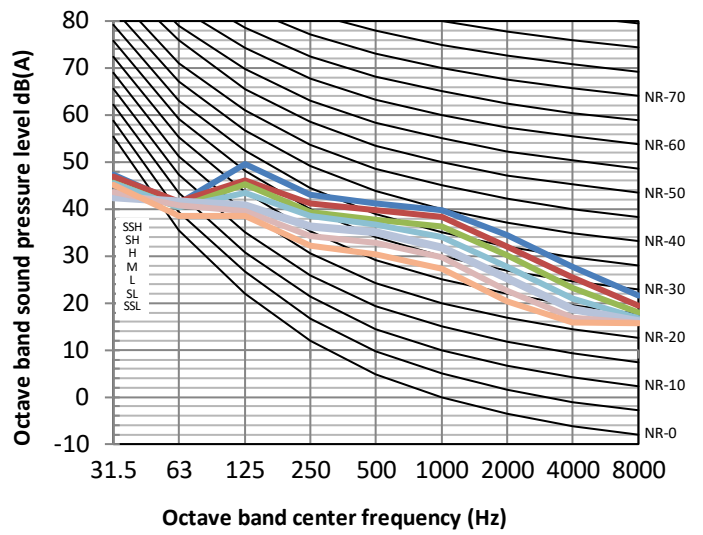

Figure 8.6: SDV6-DH140 octave band levels

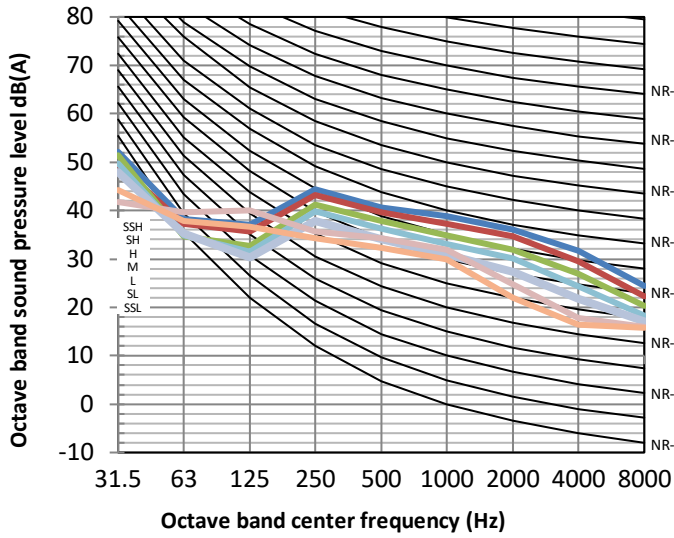

Figure 8.7: SDV6-DH160 octave band levels

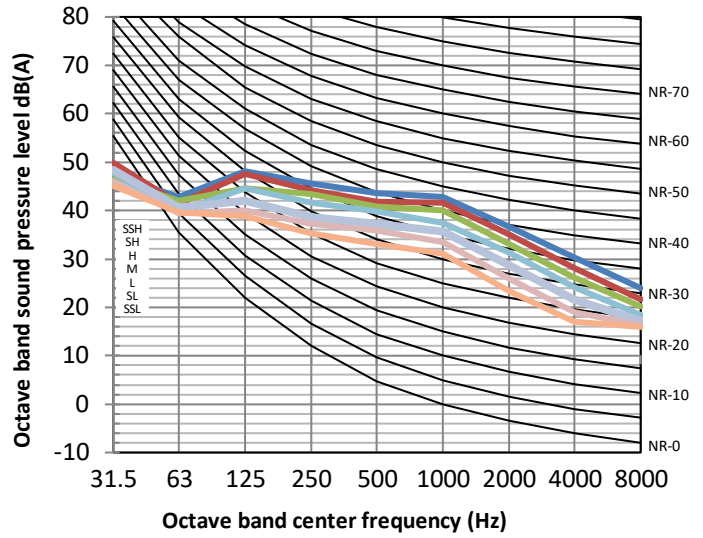

Figure 8.8: SDV6-DH200 octave band levels

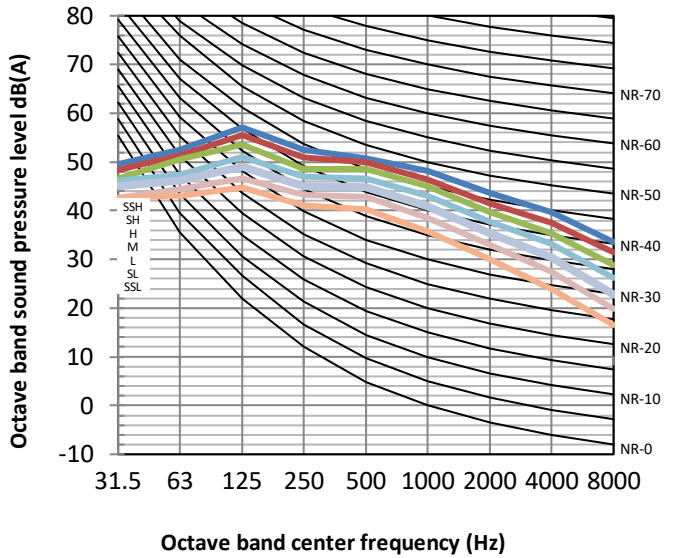

Figure 8.9: SDV6-DH224 octave band levels

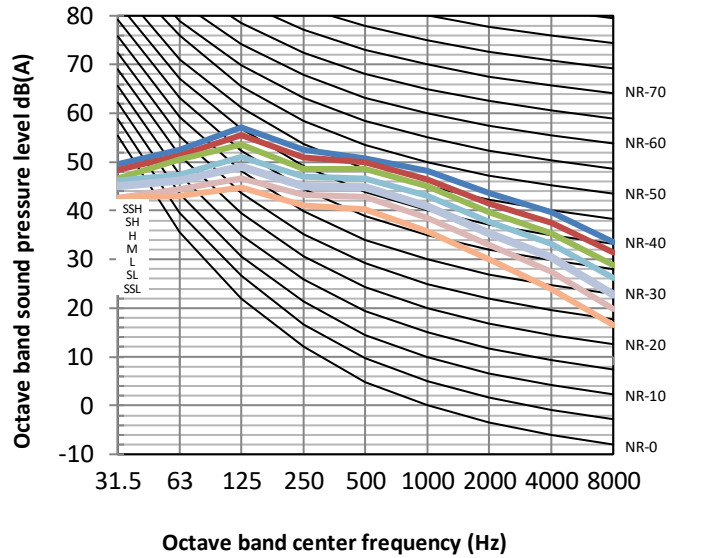

Figure 8.10: SDV6-DH252 octave band levels

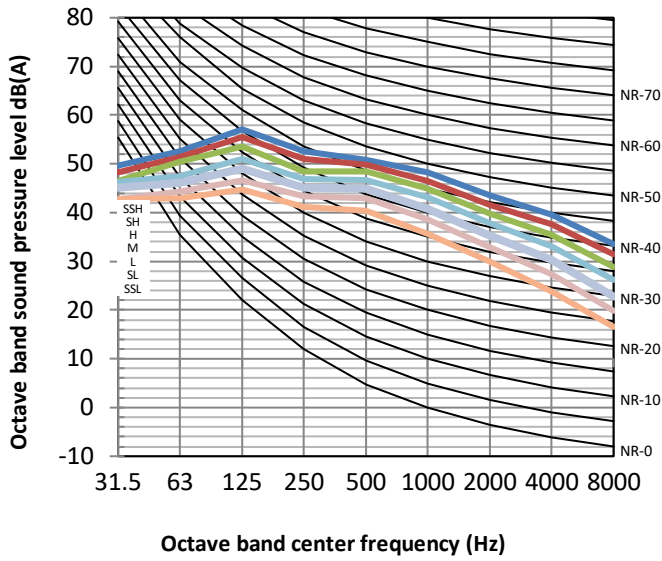

Figure 8.11: SDV6-DH280 octave band levels

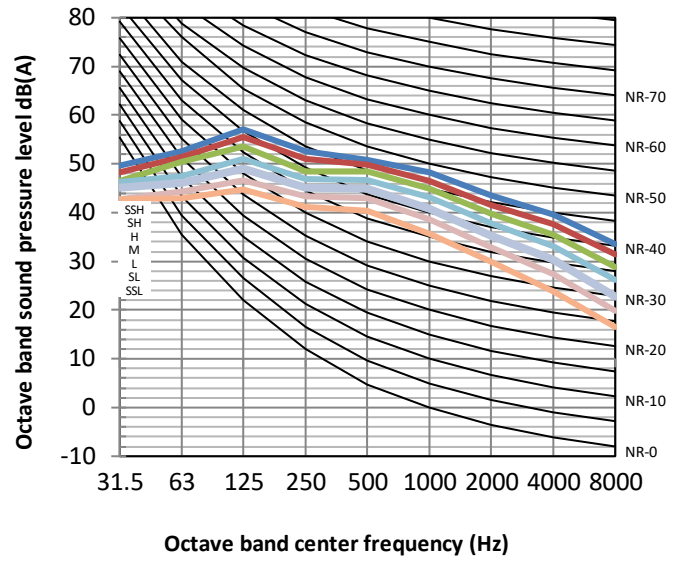

Figure 8.12: SDV6-DH335 octave band levels

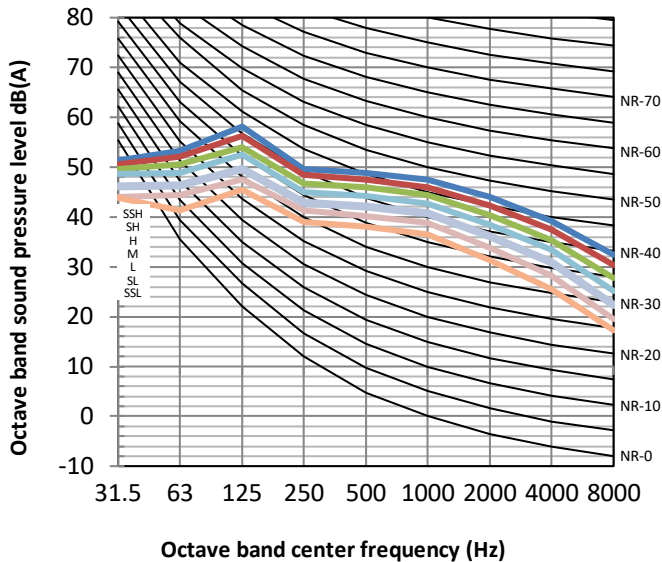

Figure 8.13: SDV6-DH400 octave band levels

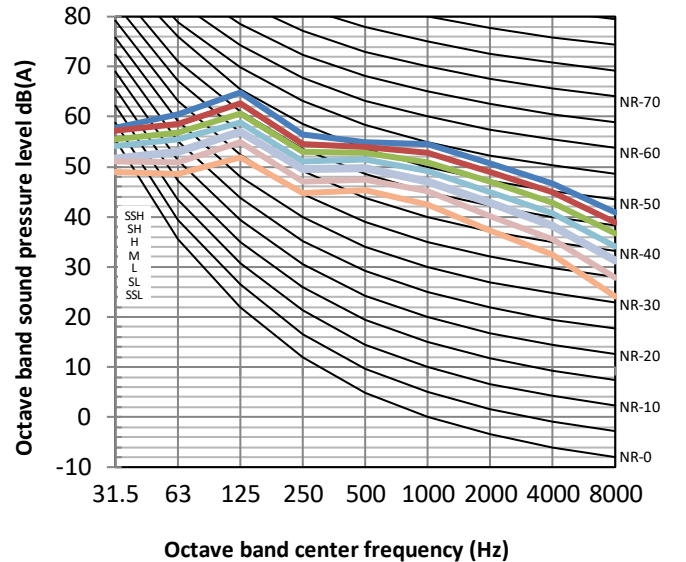

Figure 8.14: SDV6-DH450 octave band levels

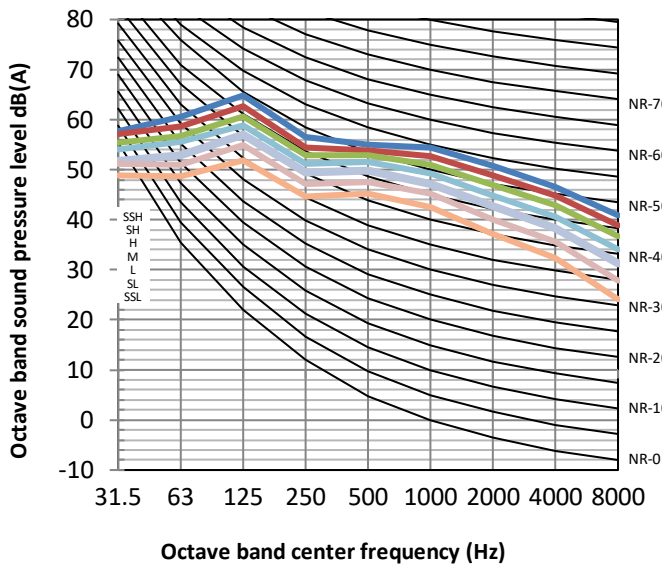
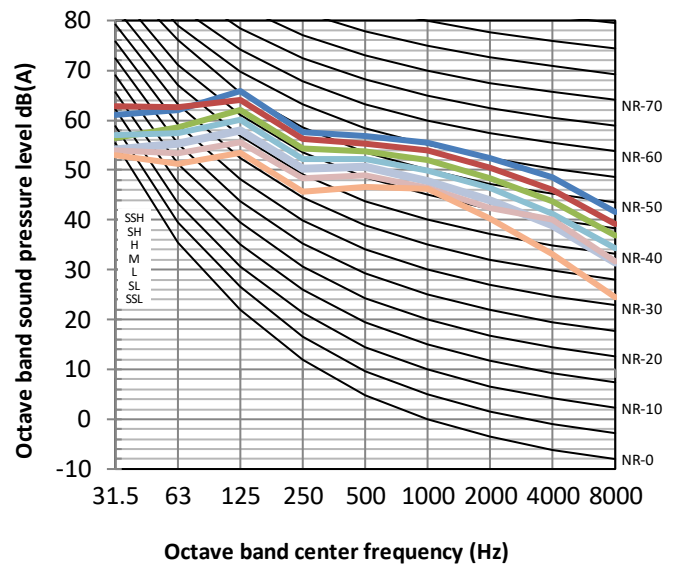

Figure 8.15: SDV6-DH560 octave band levels



## 9 Fan Performance

### 9.1 How to switch between Constant Airflow mode and Constant Speed mode

① In the main interface, press "☰" + "↵" for 3 seconds at the same time, and the main interface will display "CC". Press the "▲" and "▼" to select the indoor unit ("n00-n63" is displayed, and the last two digits are the indoor unit addresses). Press the "↵" to enter the parameter setting interface, and "n00" will be displayed.

② Press the "▲" and "▼" until "N30" is displayed on the page, and then press the "↵" to enter the mode setting. Use the "▲" and "▼" keys to adjust to the demand mode parameter values, and press the "↵" to confirm.

③ Press the "🕒" button to return to the previous menu and exit the parameter setting. Parameter setting will also exit after 60 s of no operation

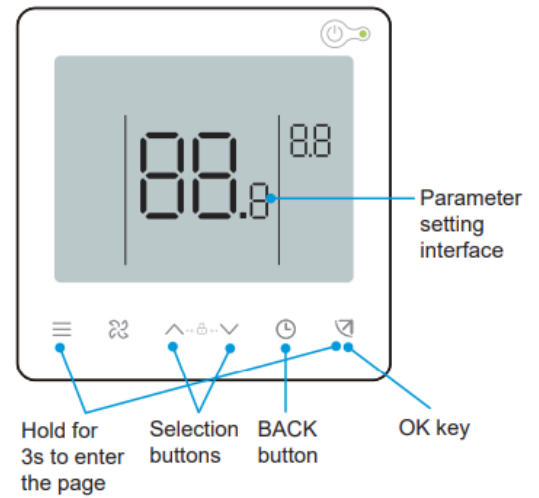

Table 9.1: Mode setting

First level menu	Second level menu	Description	Default
n30	00	Constant Speed	-
	01	Constant Airflow	√

Notes:

- The above is only an example. If you choose other controllers, please refer to their instructions for setting.

## 9.2 Constant Airflow mode

### 9.2.1 Fan performance diagram

Figure 9.1: SDV6-DH56(71,80)

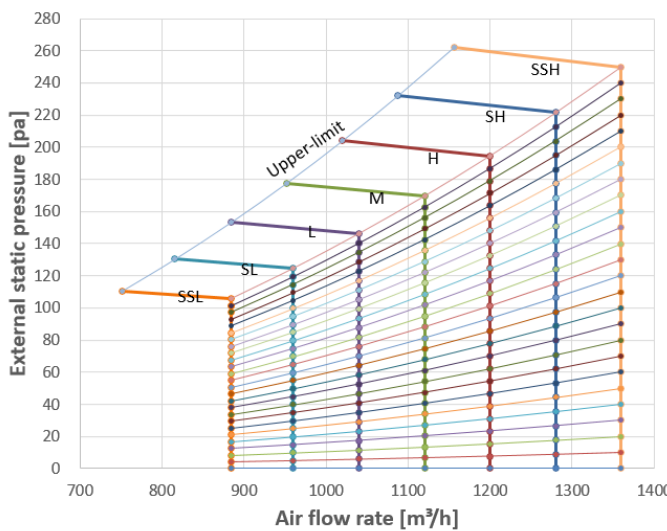

Figure 9.2: SDV6-DH90

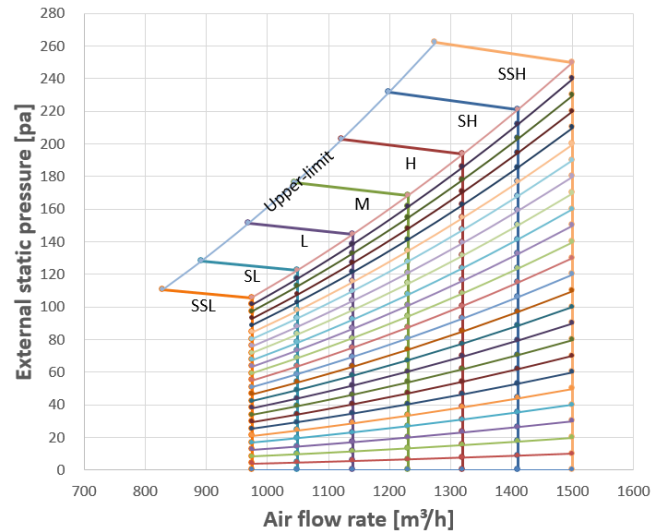

Figure 9.3: SDV6-DH112

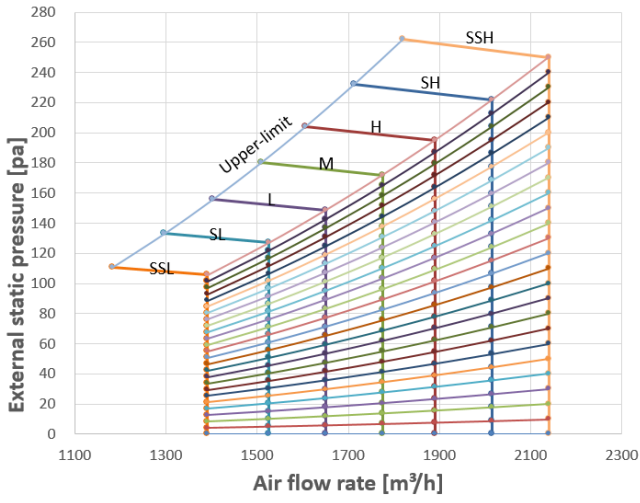

Figure 9.4: SDV6-DH125

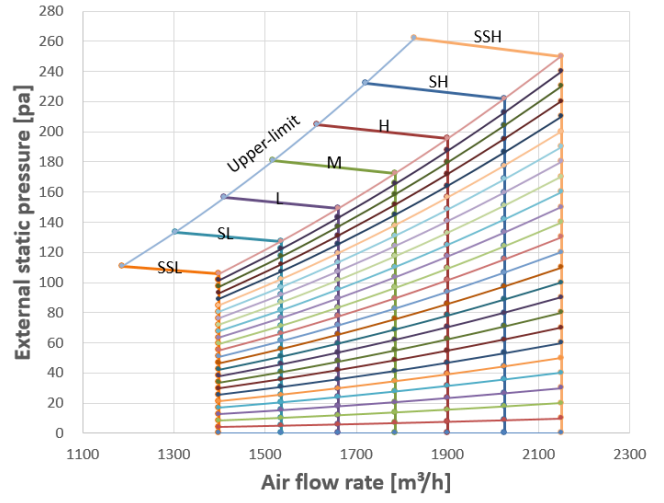

Figure 9.5: SDV6-DH140

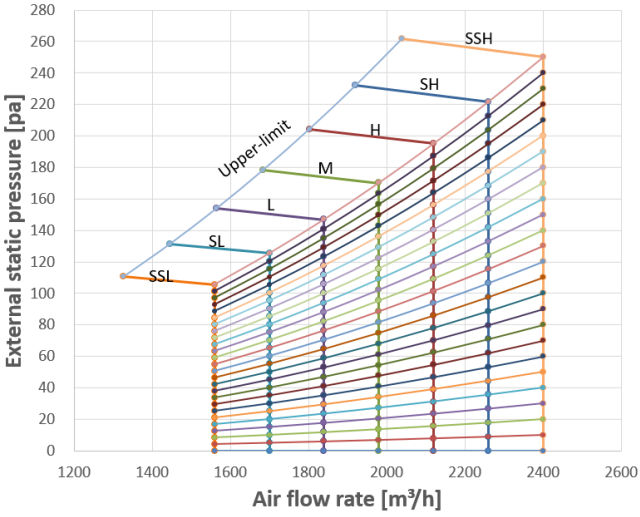

Figure 9.6: SDV6-DH160

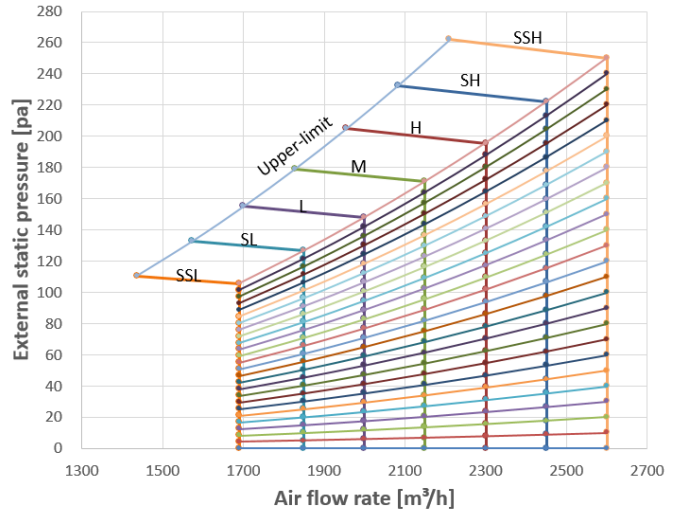

Figure 9.7: SDV6-DH200

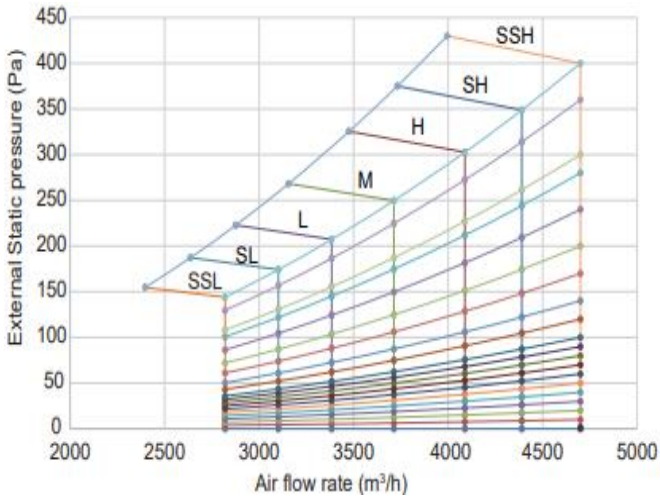

Figure 9.8: SDV6-DH224

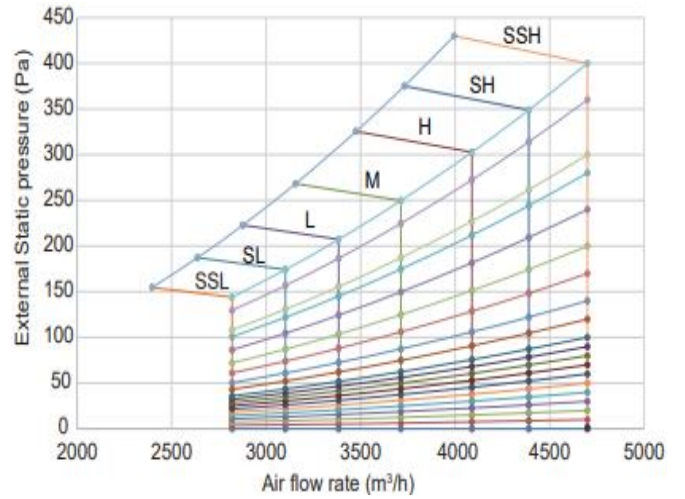

Figure 9.9: SDV6-DH252

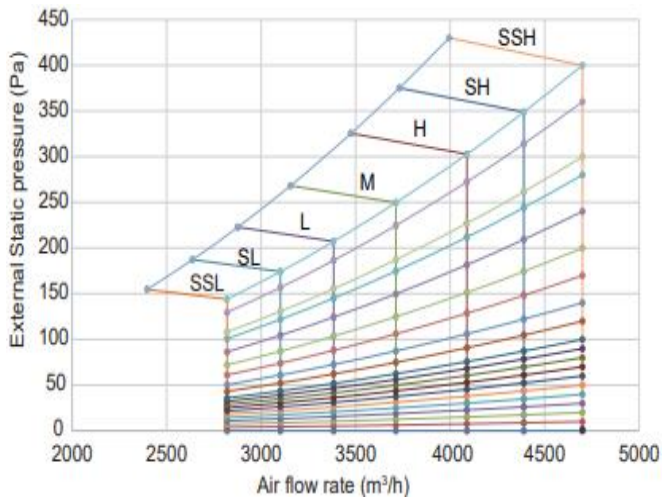

Figure 9.10: SDV6-DH280

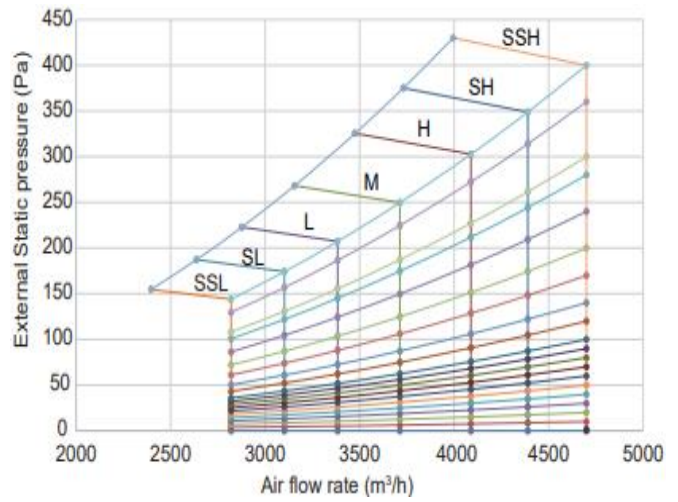

Figure 9.11: SDV6-DH335

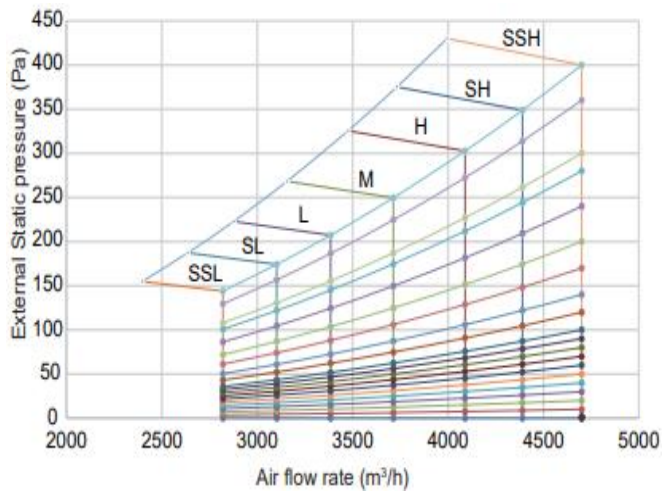

Figure 9.12: SDV6-DH400

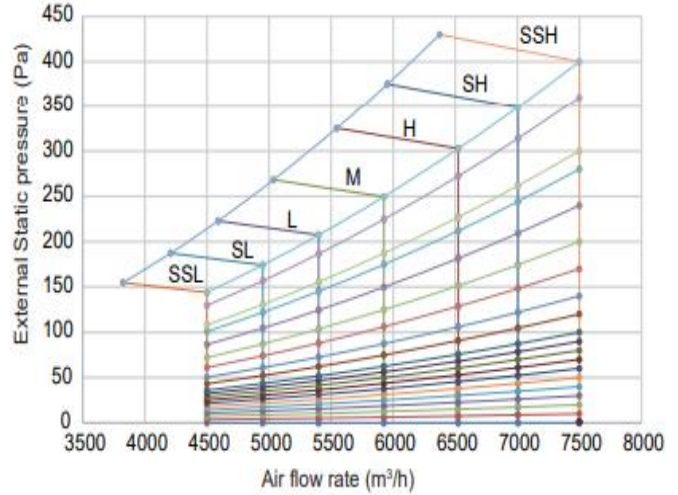

Figure 9.13: SDV6-DH450

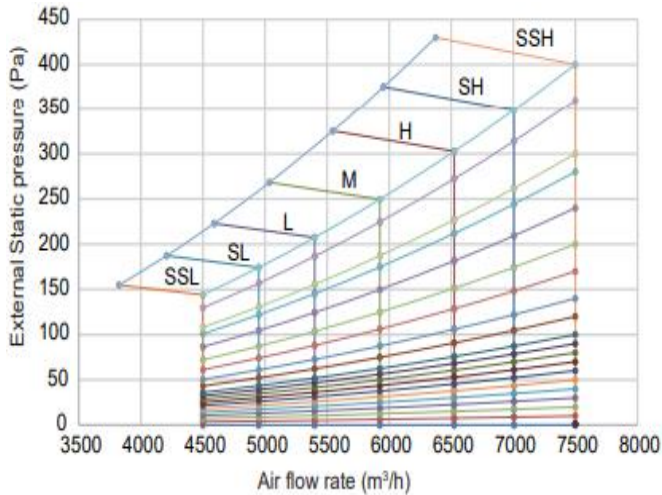
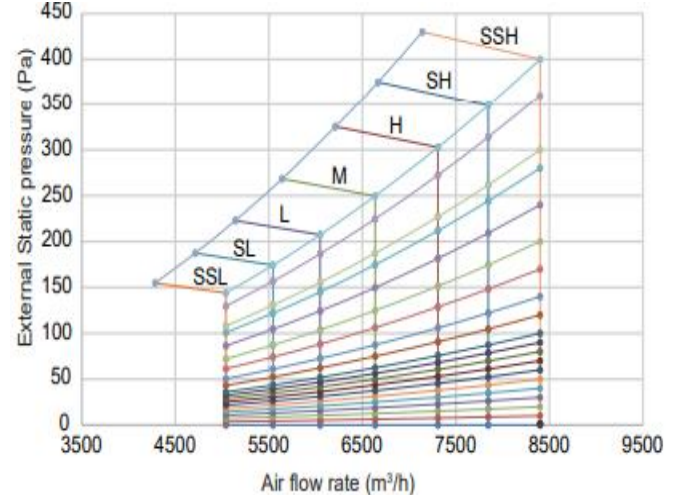

Figure 9.14: SDV6-DH560



### 9.2.2 How to Read the Diagram (Constant Airflow mode)

The vertical axis is the External Static Pressure (Pa) while the horizontal axis represents the Air Flow (m<sup>3</sup>/h). The characteristic curve for the “SSH”, “SH”, “H”, “M”, “L”, “SL” and “SSL” fan speed control.

For SDV6-DH140, in “H” windshield, when the external static pressure is less than 195 Pa, the air flow keeps 2120 m<sup>3</sup>/h, but when the external static pressure is greater than 195 Pa, the air flow begins to decline, and the allowable maximum external static pressure is 204 Pa.

## 9.3 Constant Speed mode

### 9.3.1 Set external static pressure parameters

① In the main interface, press “≡” + “↵” for 3 seconds at the same time, and the main interface will display “CC”. Press the “▲” and “▼” to select the indoor unit (“n00-n63” is displayed, and the last two digits are the indoor unit addresses). Press the “↵” to enter the parameter setting interface, and “n00” will be displayed.

② When “n00” is displayed, press the “↵” to enter the static pressure setting. Use the “▲” and “▼” keys to adjust to the demand parameter values, and press the “↵” to confirm.

③ Press the “⌚” button to return to the previous menu and exit the parameter setting. Parameter setting will also exit after 60 s of no operation

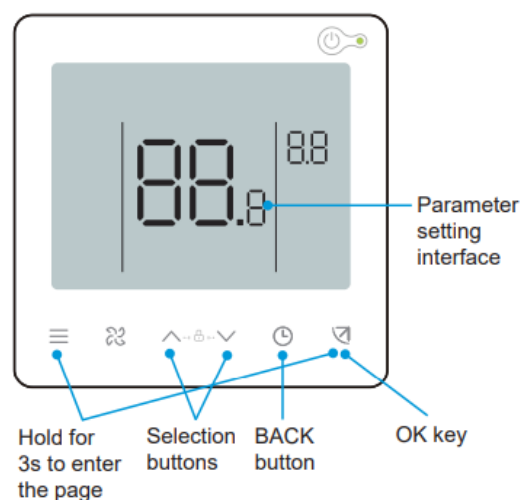

Table 9.1: External static pressure setting (5.6-16kW)

First level menu	Second level menu	Description	Default
N00	00/01/02/03/04/05/~ /19	Static pressure level	08(5.6-11.2kW) 10(12.5-16.0kW)

Level	00	01	02	03	04	05	06	07	08	09	10	11	12	13	14	15	16	17	18	19
Static pressure(Pa)	0	10	20	30	40	50	60	70	80	90	100	110	120	130	140	160	180	200	220	250

Table 9.2: External static pressure setting (20-56kW)

First level menu	Second level menu	Description	Default
N00	00/01/02/03/04/05/~ /19	Static pressure level	14(20-33.5kW) 17(40-56kW)

Level	00	01	02	03	04	05	06	07	08	09	10	11	12	13	14	15	16	17	18	19
Static pressure(Pa)	0	10	20	30	40	50	60	70	80	90	100	120	140	170	200	240	280	300	360	400

Notes:

1. The above is only an example of 86S wired controller. If you choose other controllers, please refer to their manuals for setting.

### 9.3.2 Fan performance diagram

Figure 9.15: SDV6-DH56(71,80)

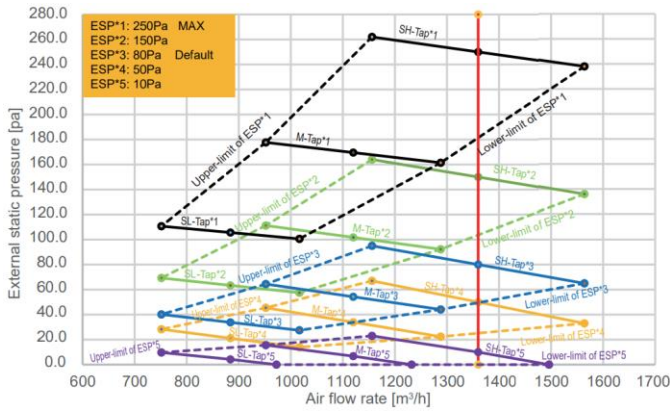

Figure 9.16: SDV6-DH90

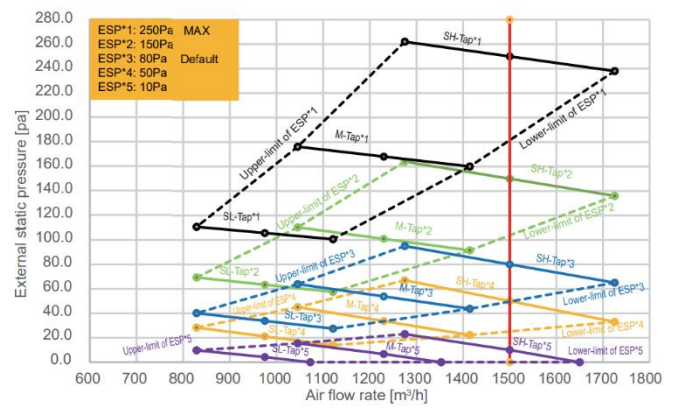

Figure 9.17: SDV6-DH112

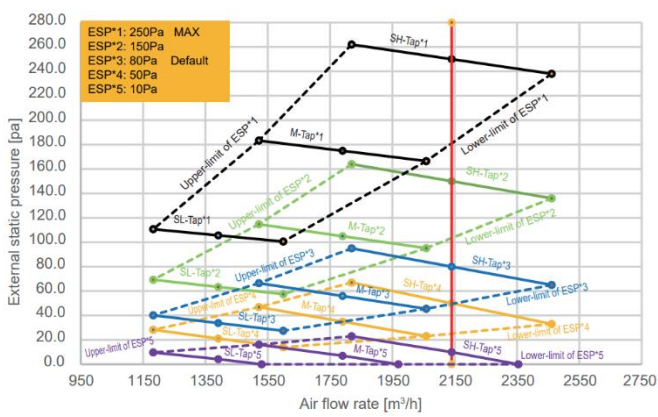

Figure 9.18: SDV6-DH125

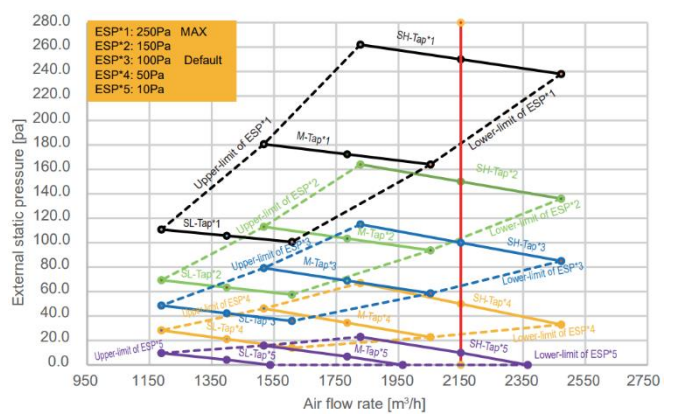

Figure 9.19: SDV6-DH140

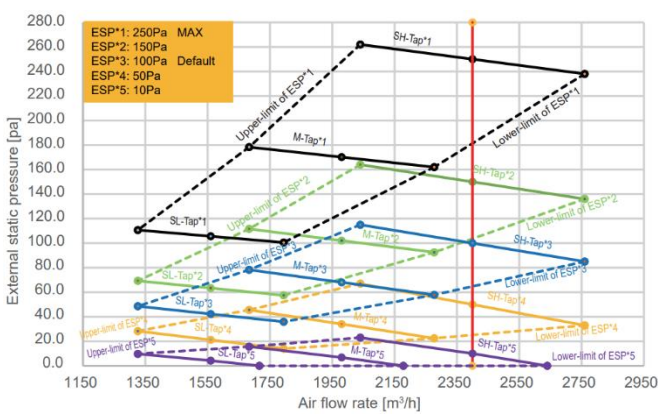

Figure 9.20: SDV6-DH160

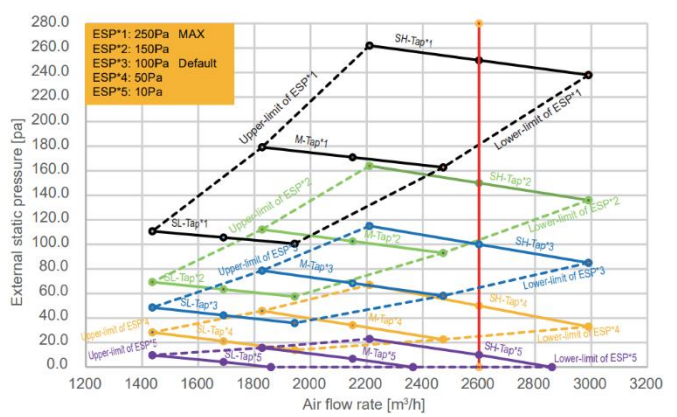

Figure 9.21: SDV6-DH200

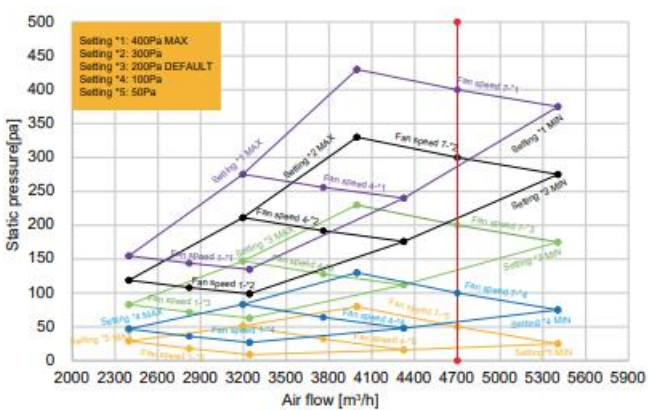

Figure 9.22: SDV6-DH224

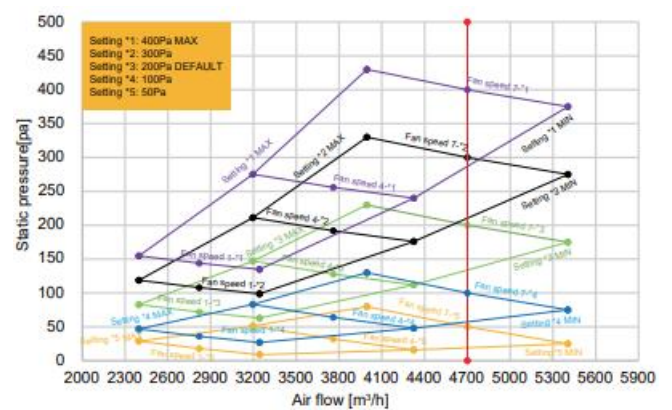

Figure 9.23: SDV6-DH252

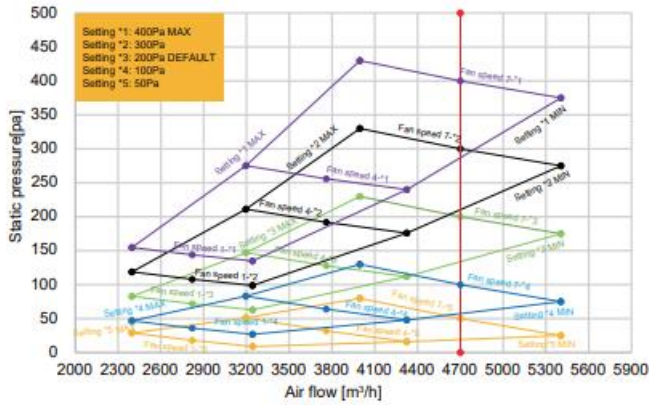

Figure 9.24: SDV6-DH280

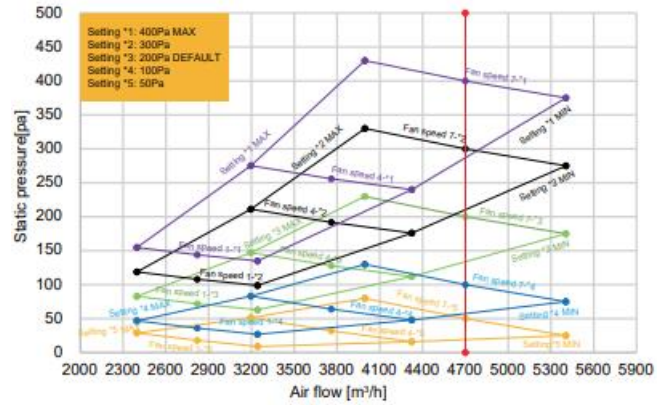

Figure 9.25: SDV6-DH335

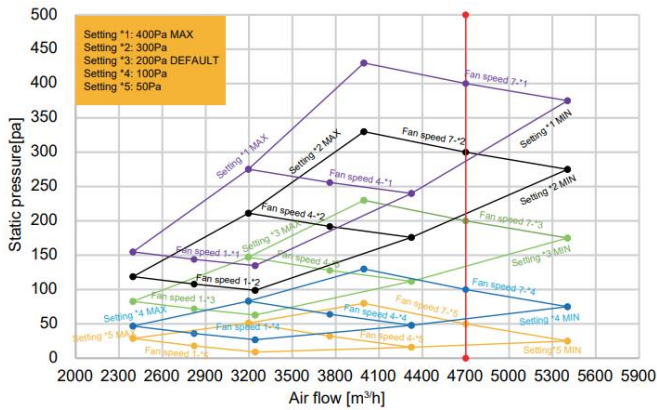

Figure 9.26: SDV6-DH400

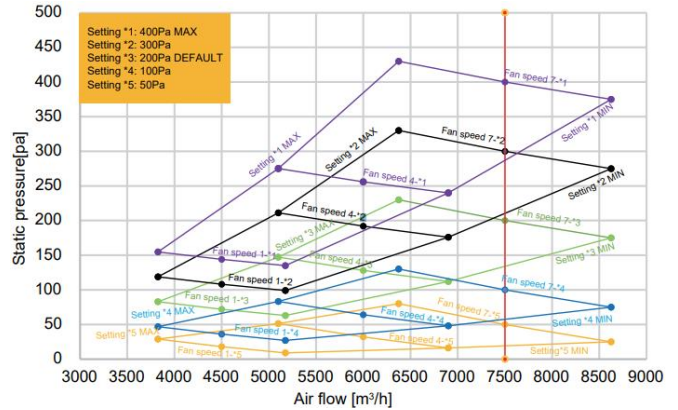

Figure 9.27: SDV6-DH450

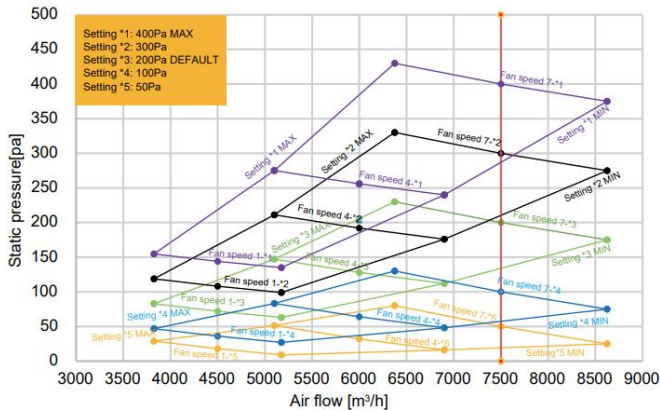
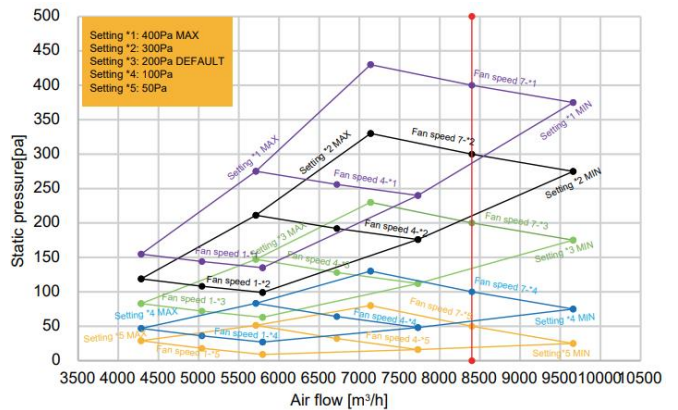

Figure 9.28: SDV6-DH560



### 9.3.3 How to Read the Diagram (Constant Speed mode)

The vertical axis is the External Static Pressure (Pa) while the horizontal axis represents the Air Flow (m<sup>3</sup>/h). The characteristic curve for the “SH”, “M” and “SL” fan speed control.

The Air Flow decreases with the increase of the external static pressure. For SDV6-DH140, in “SH” windshield and “100Pa” setting static pressure, when the external static pressure is 100Pa, the air flow is 2400 m<sup>3</sup>/h, and the allowable external static pressure range is 85Pa to 115Pa.







## NOTE CONCERNING PROTECTION OF ENVIRONMENT



This product must not be disposed of via normal household waste after its service life, but must be taken to a collection station for the recycling of electrical and electronic devices. The symbol on the product, the operating instructions or the packaging indicate such disposal procedures. The materials are recyclable in accordance with their respective symbols. By means of re-use, material recycling or any other form of recycling old appliances you are making an important contribution to the protection of our environment. Please ask your local council where your nearest disposal station is located.

## INFORMATION CONCERNING USED REFRIGERANT MEDIUM

This unit is containing fluorinated gases included in the Kyoto protocol.  
The maintenance and the liquidation must be carried out by qualified personnel.

Type of refrigerant: R32/R410a

The composition of the cooling medium R32: (100% HFC-32)

The composition of the cooling medium R410a: (50% HFC-32, 50% HFC-125)

The quantity of the refrigerant: Please see the unit label.

The value GWP of R32: 675 (1 kg R32 = 0,675 t CO<sub>2</sub> eq)

The value GWP of R410a: 2088 (1kg R410a=2,088t CO<sub>2</sub> eq)

GWP = Global Warming Potential

**NOTE:** Indoor unit can use R32 and R410a, it depends on outdoor unit.



Appliance filled with flammable gas R32.

In case of quality problem or other please contact your local supplier or authorized service center.

**Emergency number: 112**

## PRODUCER

SINCLAIR CORPORATION Ltd.  
16 Great Queen Street  
WC2B 5AH London  
United Kingdom  
[www.sinclair-world.com](http://www.sinclair-world.com)

This product was manufactured in China (Made in China).

## REPRESENTATIVE

SINCLAIR Global Group s.r.o.  
Purkynova 45  
612 00 Brno  
Czech Republic

## TECHNICAL SUPPORT

SINCLAIR Global Group s.r.o.  
Purkynova 45  
612 00 Brno  
Czech Republic  
Tel.: +420 800 100 285 | Fax: +420 541 590 124  
[www.sinclair-solutions.com](http://www.sinclair-solutions.com) | [info@sinclair-solutions.com](mailto:info@sinclair-solutions.com)

