

AIR-COOLED DC INVERTER MODULAR CHILLER UNIT

SERVICE MANUAL

SCV-300EB/EBH
SCV-600EB/EBH



SINCLAIR
AIR CONDITIONING

CONTENTS

Part 1 General Information.....	3
Part 2 Component Layout and Refrigerant Circuits	5
Part 3 Control	23
Part 4 Diagnosis and Troubleshooting.....	39



Part 1

General Information

1	Unit Capacities and External Appearance.....	4
2	Water outlet temperature range.....	4

1 Unit Capacities and External Appearance

Table 1-1.1: Sinclair modular chiller unit capacity range and unit appearances

Capacity	30kW	60kW
Model	SCV-300EB	SCV-600EB
Appearance		
Power supply	380-415V/3Ph/50Hz	

SCV-300EBH and SCV-600EBH include hydraulic module

2 Water outlet temperature range

Table 1-2.1: water outlet temperature range

Mode		Range
Cooling	Normal	5-20°C ¹
	Low water outlet	0-20°C(reserved) ²
Heating	Normal	25-54°C

Notes:

1. For 30kW and 60kW units, when the ambient temperature is below 15°C, the water outlet temperature range is 10-20°C. When the ambient temperature is above 15°C, all the units water outlet temperature range is 5-20°C.
2. For 30kW and 60kW units, use dial switch S12_3 on the main PCB to select the water outlet temperature range.

Part 2

Component Layout and Refrigerant Circuits

1	Layout of Functional Components	6
2	Piping Diagrams	14
3	Refrigerant Flow Diagrams	20

1 Layout of Functional Components

SCV-300EB

Figure 2-1.1: SCV-300EB front view

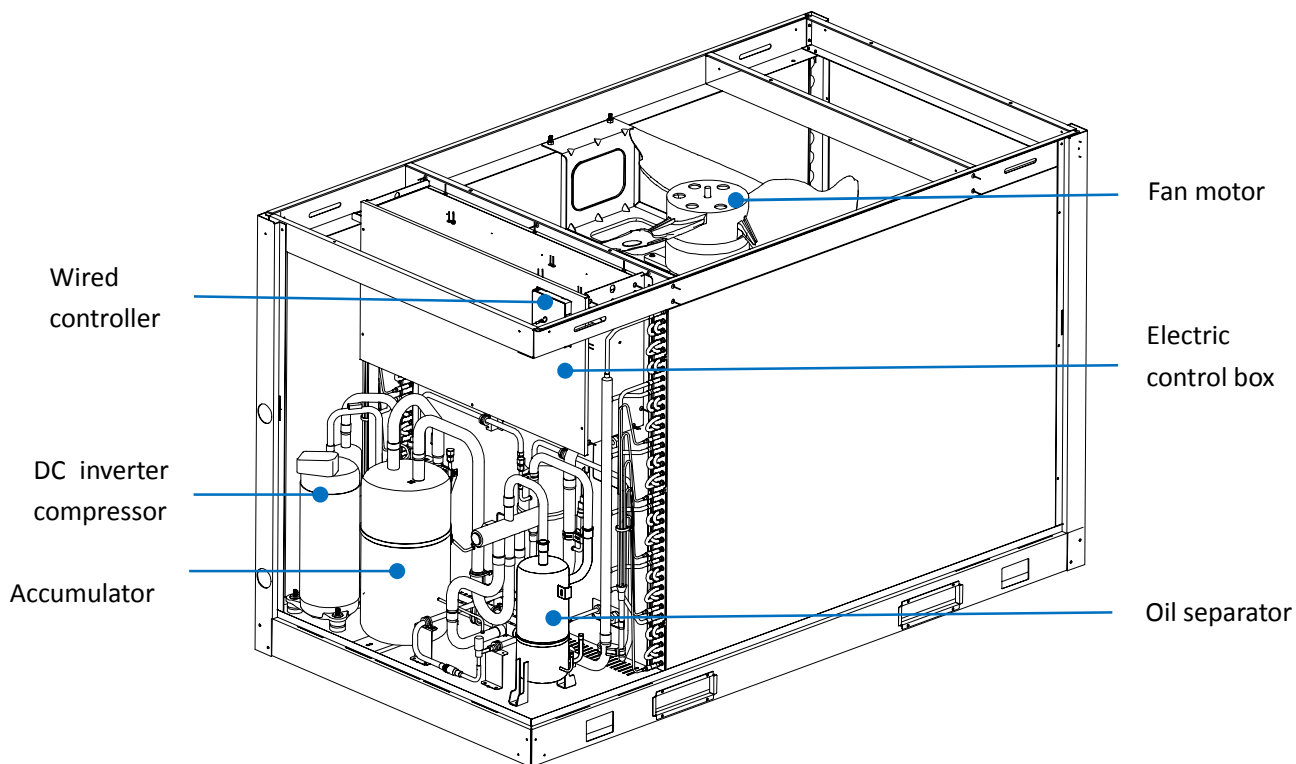

Figure 2-1.2: SCV-300EB rear view

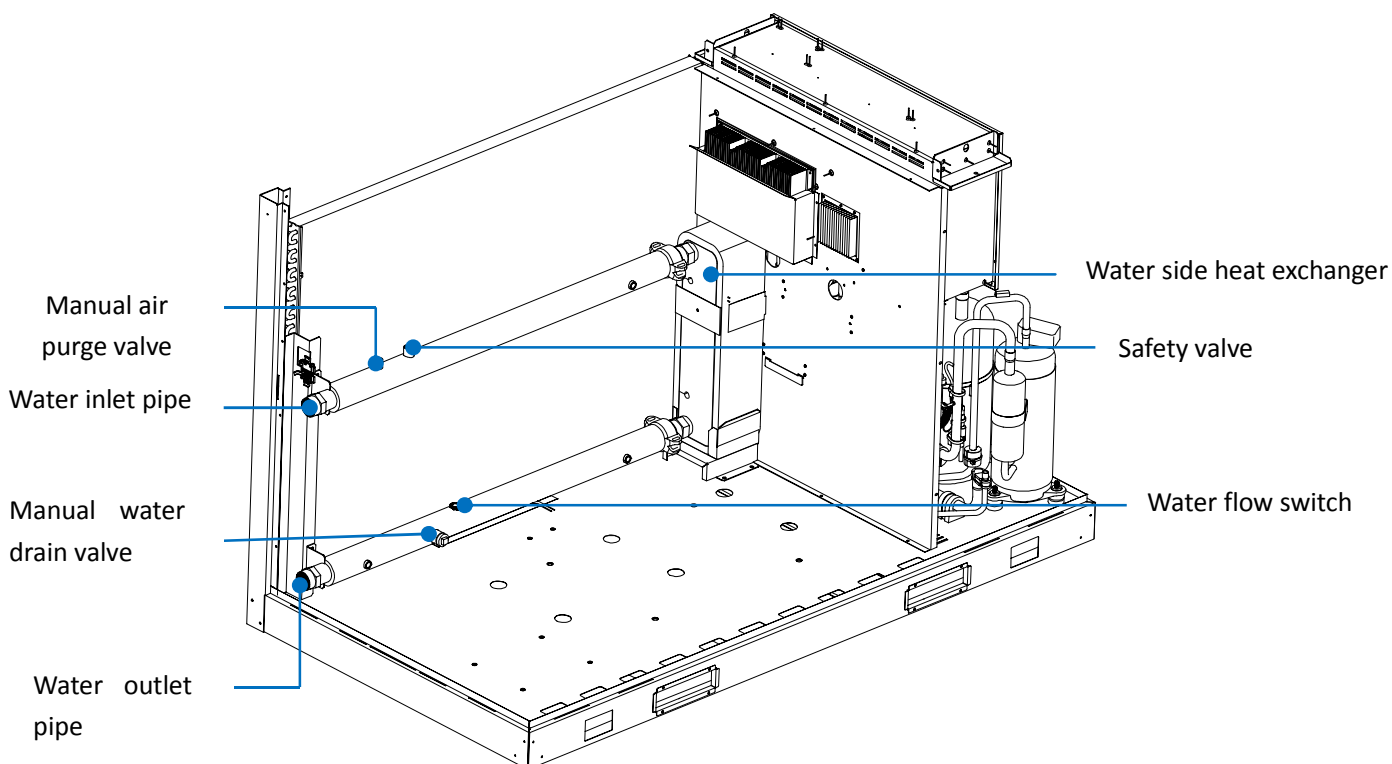
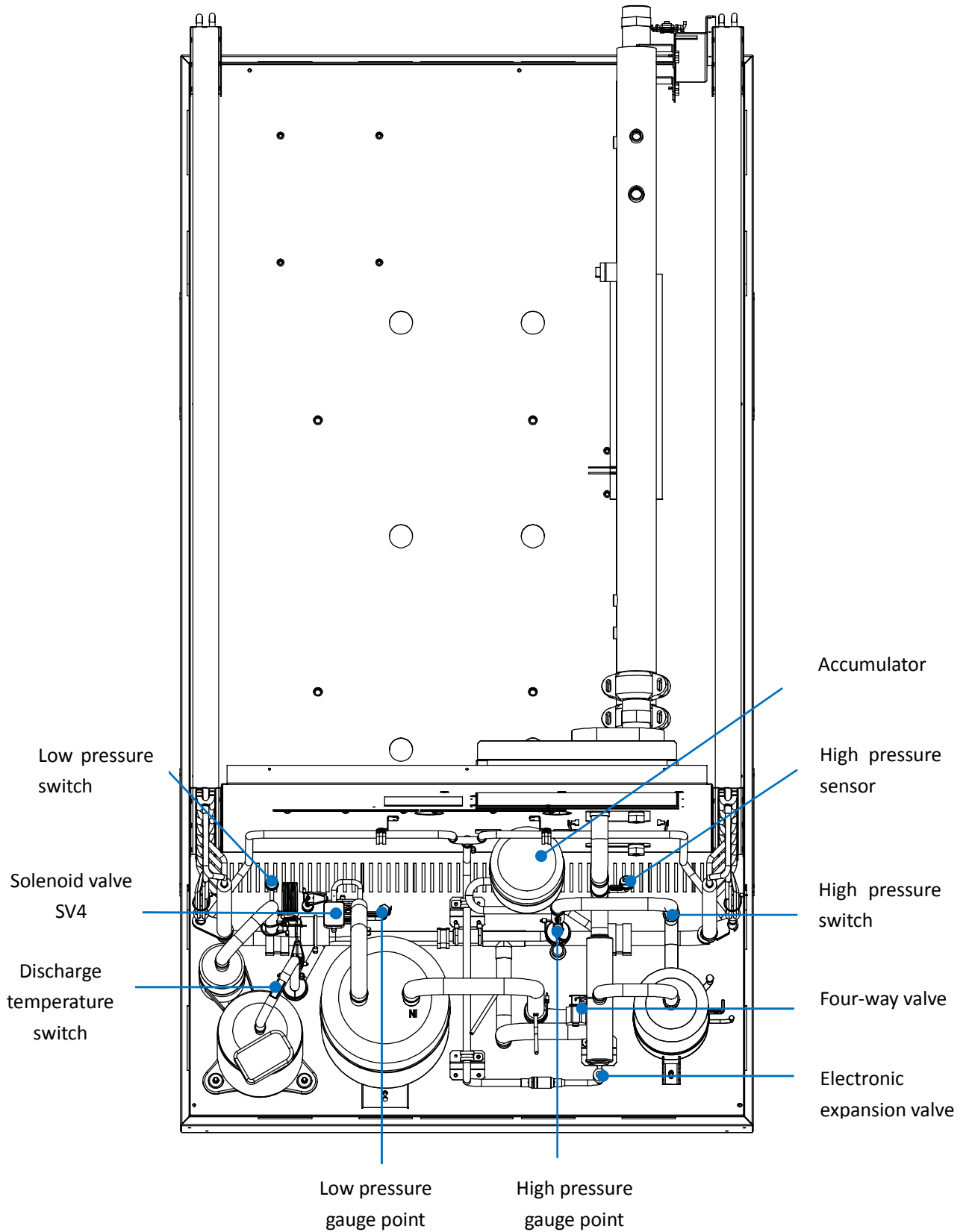

Figure 2-1.3: SCV-300EB top view



SCV-300EBH 30 kW version with hydro module

Figure 2-1.4: 30 kW version with hydro module front view

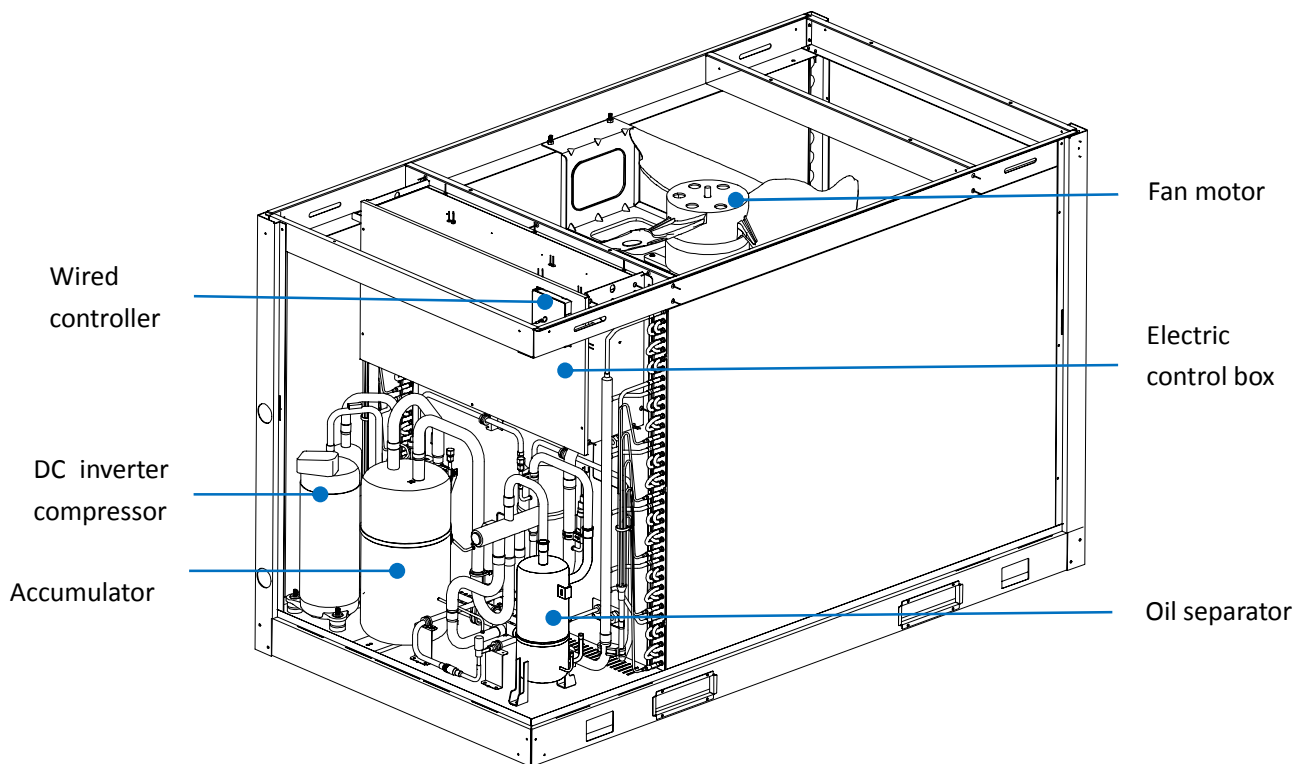

Figure 2-1.5: 30 kW version with hydro module rear view

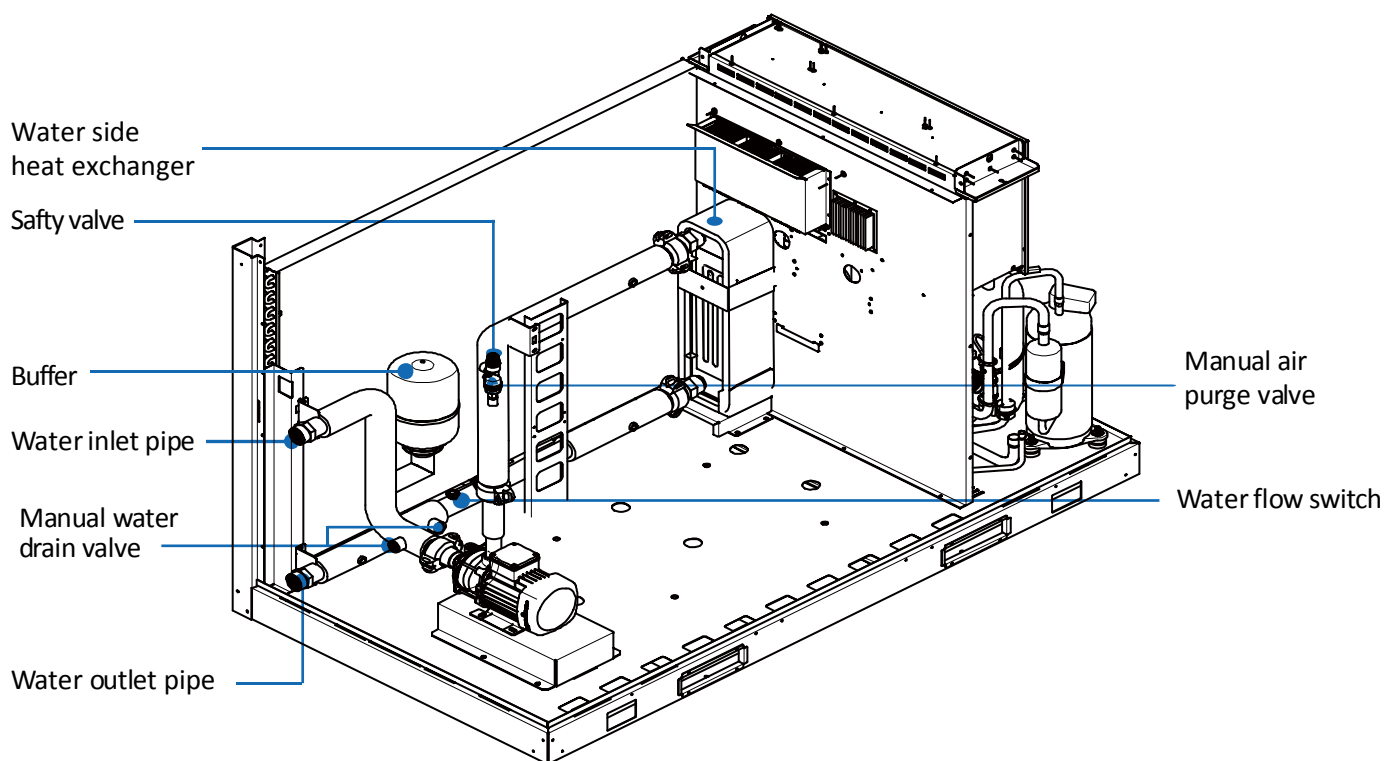
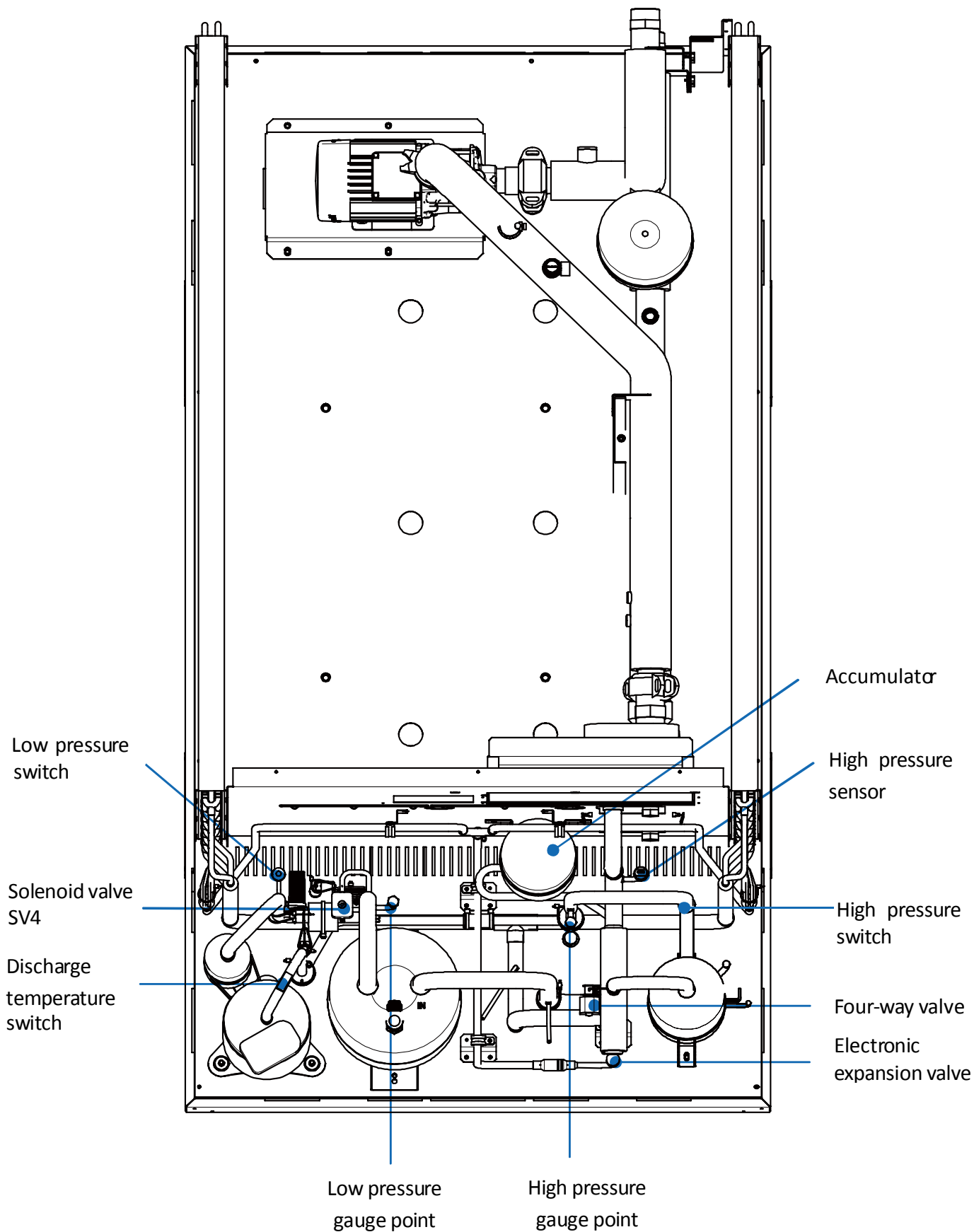

Figure 2-1.6: 30 kW version with hydro module top view



SCV-600EB

Figure 2-1.7: SCV-600EB front view

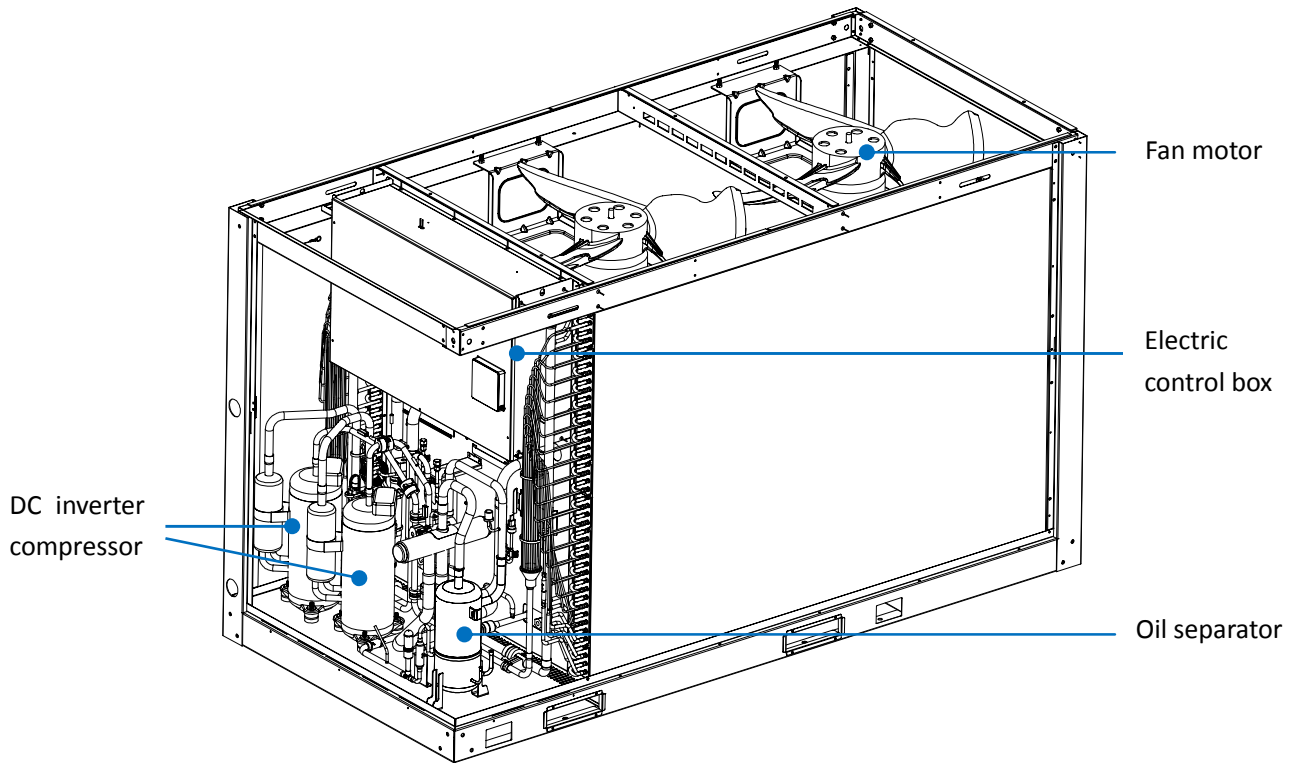

Figure 2-1.8: SCV-600EB rear view

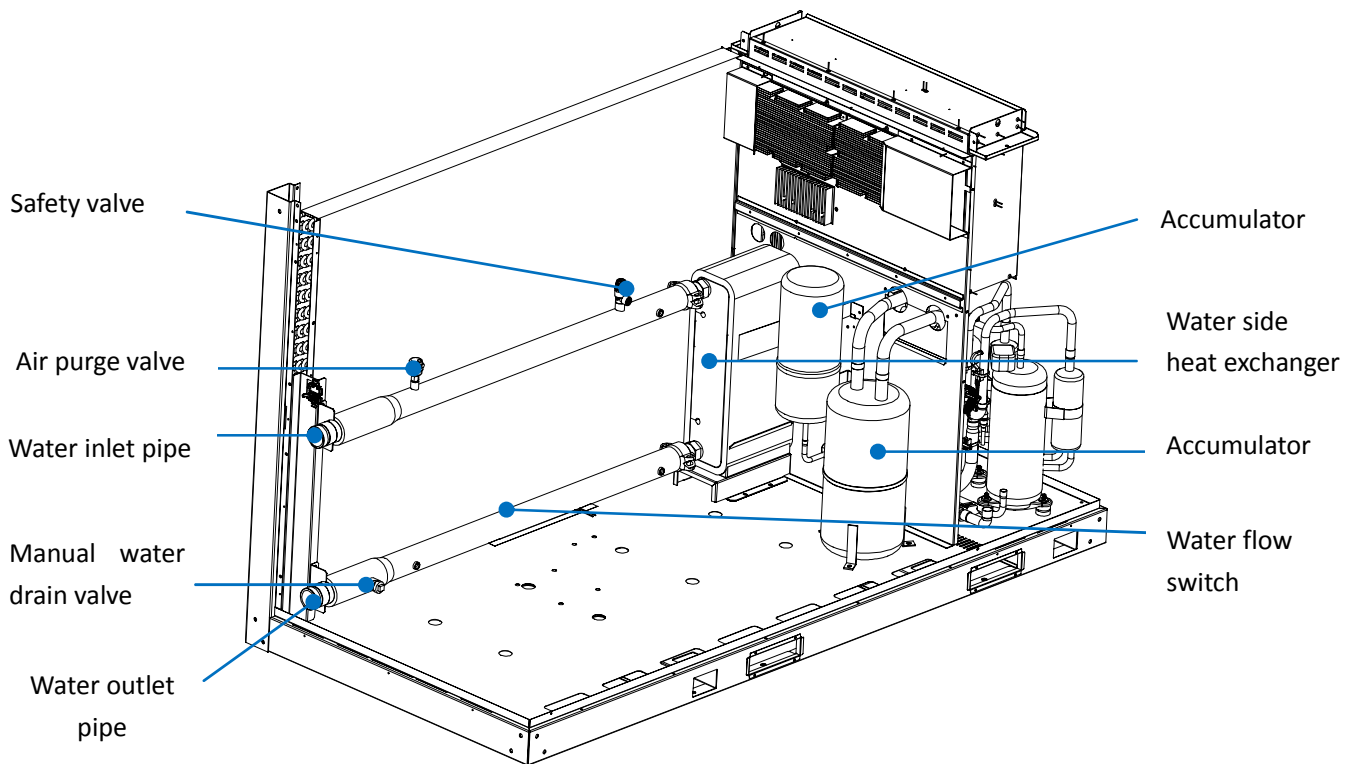
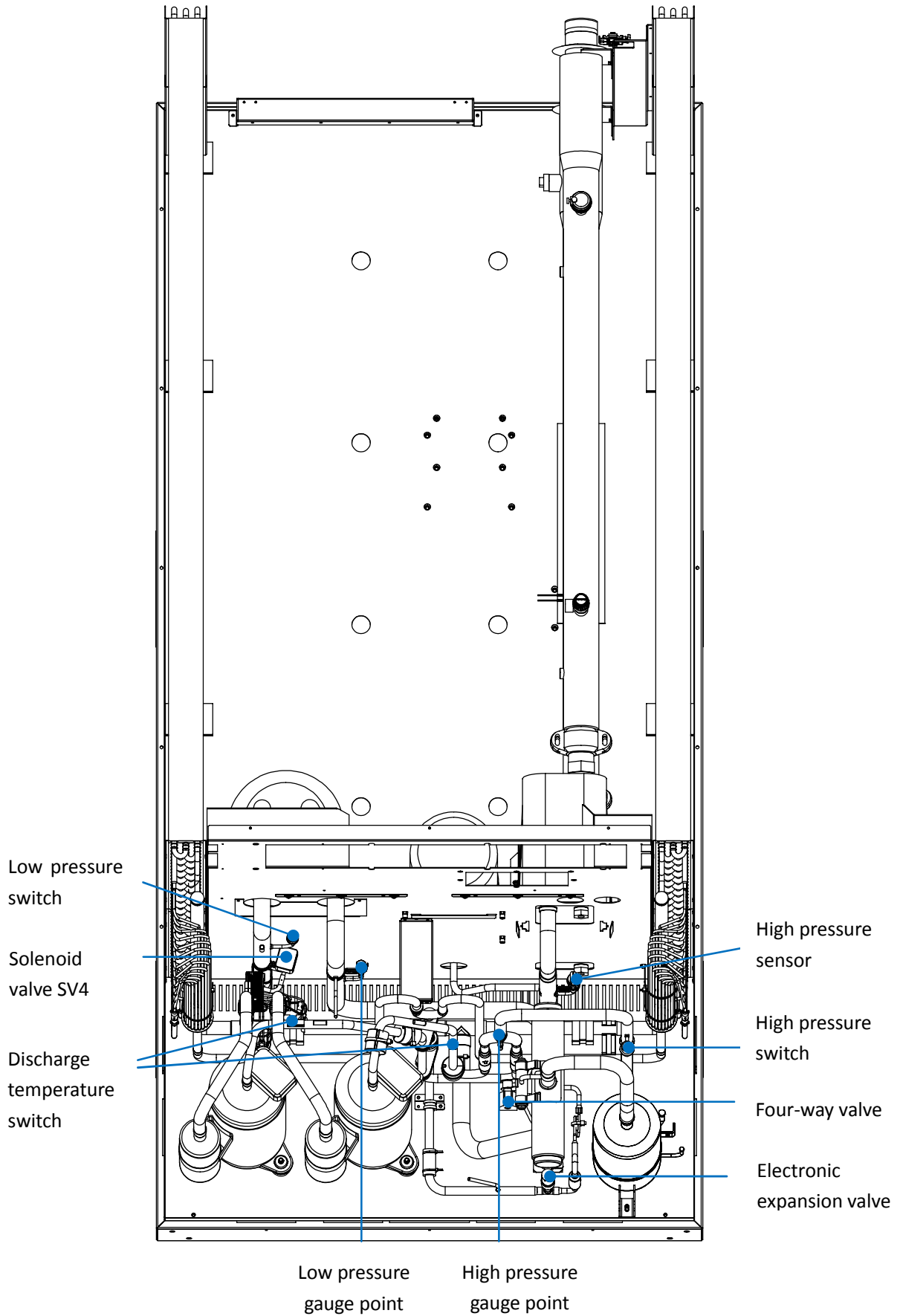

Figure 2-1.9: SCV-600EB top view



SCV-600EBH 60 kW version with hydro module

Figure 2-1.10: 60 kW version with hydro module front view

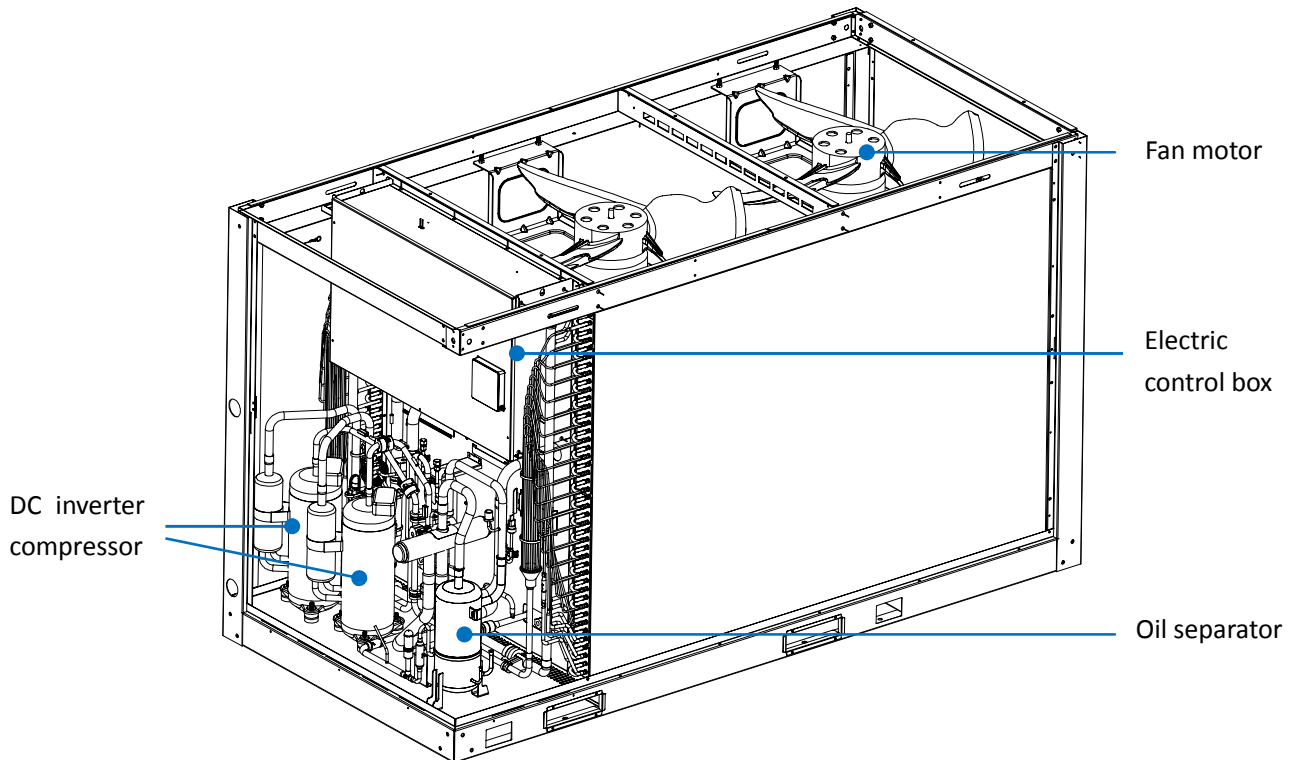

Figure 2-1.11: 60 kW version with hydro module rear view

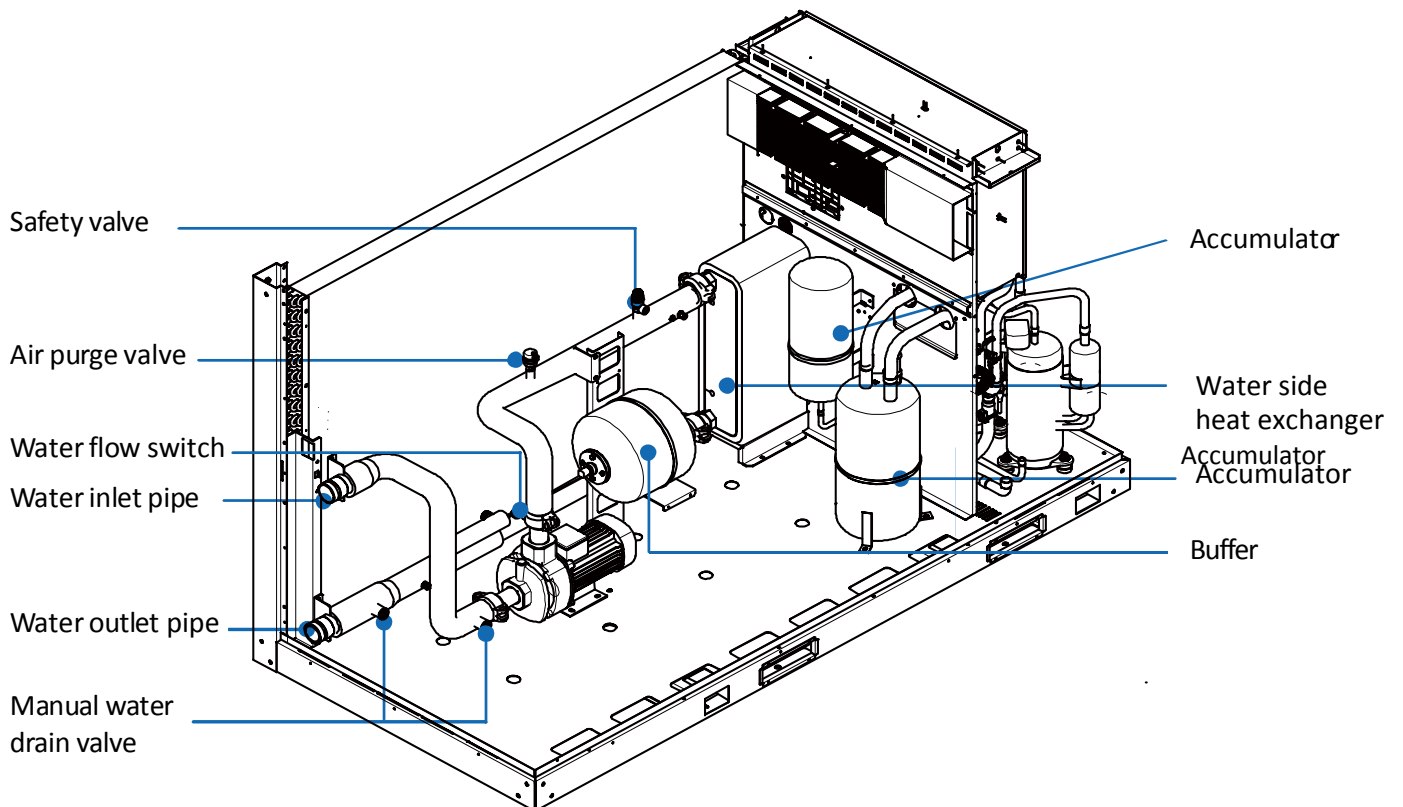
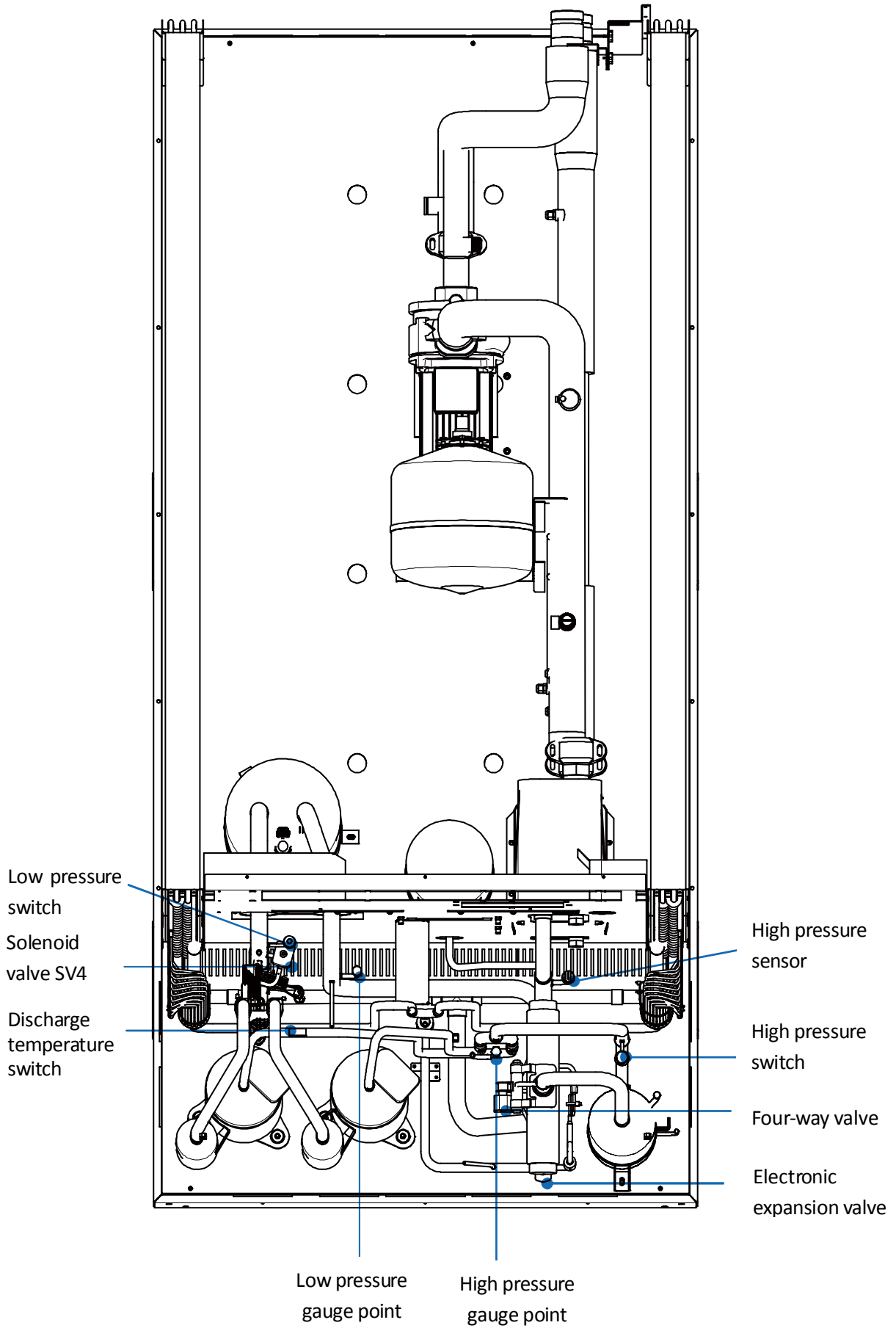

Figure 2-1.12: 60 kW version with hydro module top view



2 Piping Diagrams

SCV-300EB

Figure 2-2.1: SCV-300EB piping diagram

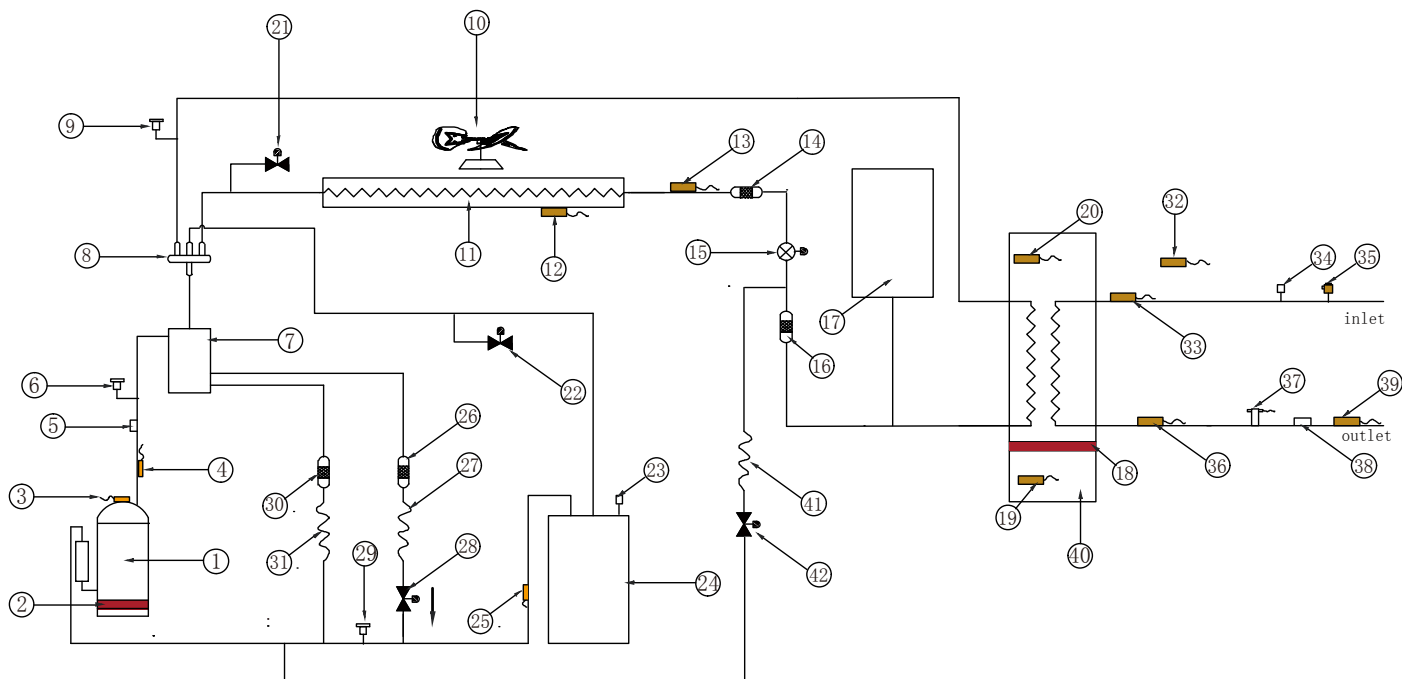

Legend			
1	DC inverter compressor	22	Stop valve
2	Crankcase heater	23	Safety valve
3	DC inverter compressor discharge temperature sensor 1	24	Vapor-liquid separator
4	DC inverter compressor discharge temperature sensor 2	25	Suction temperature sensor
5	Discharge temperature control switch	26	Filter
6	High pressure switch	27	Capillary
7	Oil separator	28	Fast oil return solenoid valve
8	4-way-valve	29	Low pressure switch
9	System pressure sensor	30	Filter
10	DC fan	31	Capillary
11	Condenser	32	Outdoor ambient temperature sensor
12	Coil outlet temperature sensor	33	Unit water inlet temperature sensor
13	Coil final outlet temperature sensor	34	Safety valve
14	Filter	35	Air purge valve
15	Electronic expansion valve	36	Unit water outlet temperature sensor
16	Filter	37	Water flow switch
17	High pressure tank	38	Manual water drain valve
18	Antifreeze heater of plater heat exchanger	39	Total outlet water temperature sensor
19	Water side antifreeze temperature sensor 2	40	Plate heat exchanger
20	Water side antifreeze temperature sensor 1	41	Capillary
21	Stop valve	42	Liquid injection solenoid valve

SCV-300EBH 30 kW version with hydro module

Figure 2-2.2: 30 kW version with hydro module piping diagram

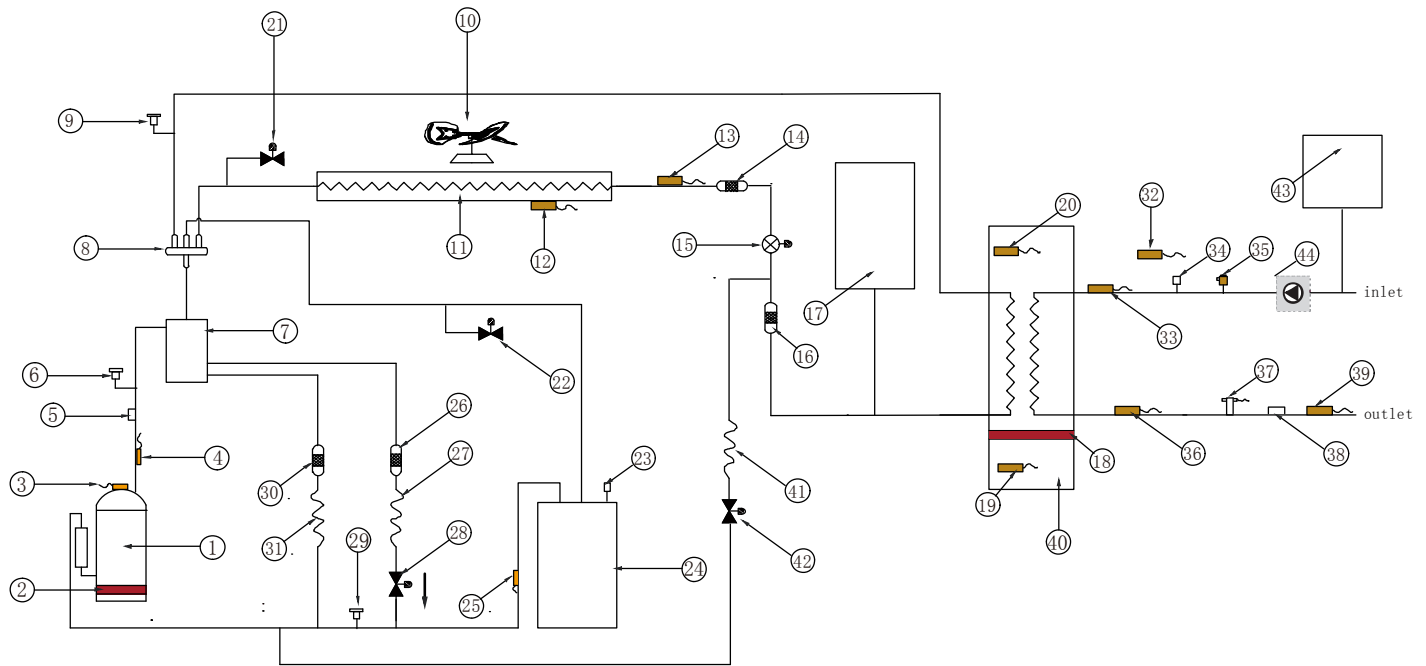

Legend			
1	DC inverter compressor	23	Safety valve
2	Crankcase heater	24	Vapor-liquid separator
3	DC inverter compressor discharge temperature sensor 1	25	Suction temperature sensor
4	DC inverter compressor discharge temperature sensor 2	26	Filter
5	Discharge temperature control switch	27	Capillary
6	High pressure switch	28	Fast oil return solenoid valve
7	Oil separator	29	Low pressure switch
8	4-way-valve	30	Filter
9	System pressure sensor	31	Capillary
10	DC fan	32	Outdoor ambient temperature sensor
11	Condenser	33	Unit water inlet temperature sensor
12	Coil outlet temperature sensor	34	Safety valve
13	Coil final outlet temperature sensor	35	Air purge valve
14	Filter	36	Unit water outlet temperature sensor
15	Electronic expansion valve	37	Water flow switch
16	Filter	38	Manual water drain valve
17	High pressure tank	39	Total outlet water temperature sensor
18	Antifreeze heater of plater heat exchanger	40	Plate heat exchanger
19	Water side antifreeze temperature sensor 2	41	Capillary
20	Water side antifreeze temperature sensor 1	42	Liquid injection solenoid valve
21	Stop valve	43	Expansion tank
22	Stop valve	44	Pump

SCV-600EB

Figure 2-2.3: SCV-600EB piping diagram

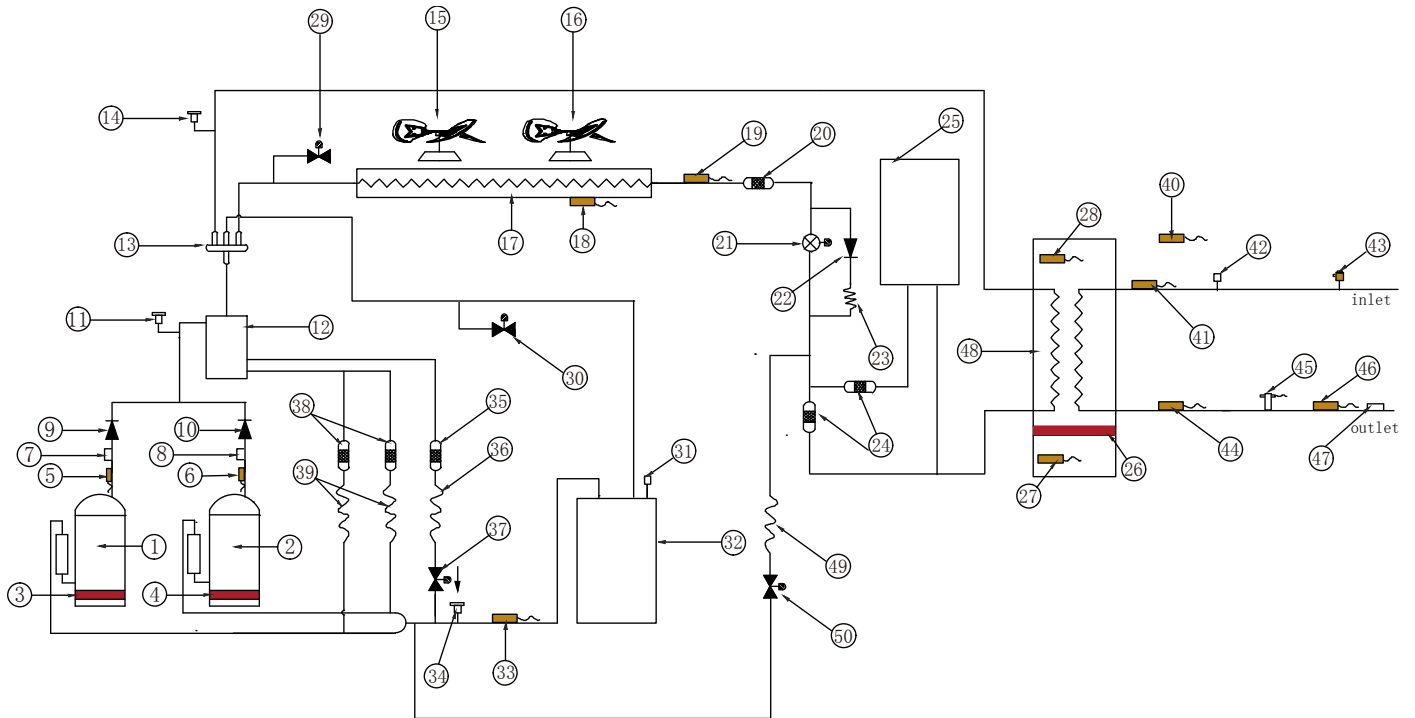

Legend			
1	DC inverter compressor 1	26	Antifreeze heater of plate heat exchanger
2	DC inverter compressor 2	27	Water side antifreeze temperature sensor 2
3	Crankcase heater 1	28	Water side antifreeze temperature sensor 1
4	Crankcase heater 2	29	Stop valve
5	DC inverter compressor discharge temperature sensor 1	30	Stop valve
6	DC inverter compressor discharge temperature sensor 2	31	Safety valve
7	Discharge temperature control switch 1	32	Vapor-liquid separator
8	Discharge temperature control switch 2	33	Suction temperature sensor
9	One-way valve 1	34	Low pressure switch
10	One-way valve 2	35	Filter
11	High pressure switch	36	Capillary
12	Oil separator	37	Fast oil return solenoid valve
13	4-way valve	38	Filter
14	System pressure sensor	39	Capillary
15	DC fan 1	40	Outdoor ambient temperature sensor
16	DC fan 2	41	Unit water inlet temperature sensor
17	Condenser	42	Safety valve
18	Coil outlet temperature sensor	43	Air purge valve
19	Coil final outlet temperature sensor	44	Unit water outlet temperature sensor
20	Filter	45	Water flow switch
21	Electronic expansion valve	46	Total outlet water temperature sensor
22	One-way valve 3	47	Manual water drain valve
23	Capillary	48	Plater exchanger
24	Filter	49	Capillary
25	High pressure tank	50	Liquid injection solenoid valve

SCV-600EBH 60 kW version with hydro module

Figure 2-2.4: 60 kW version with hydro module piping diagram

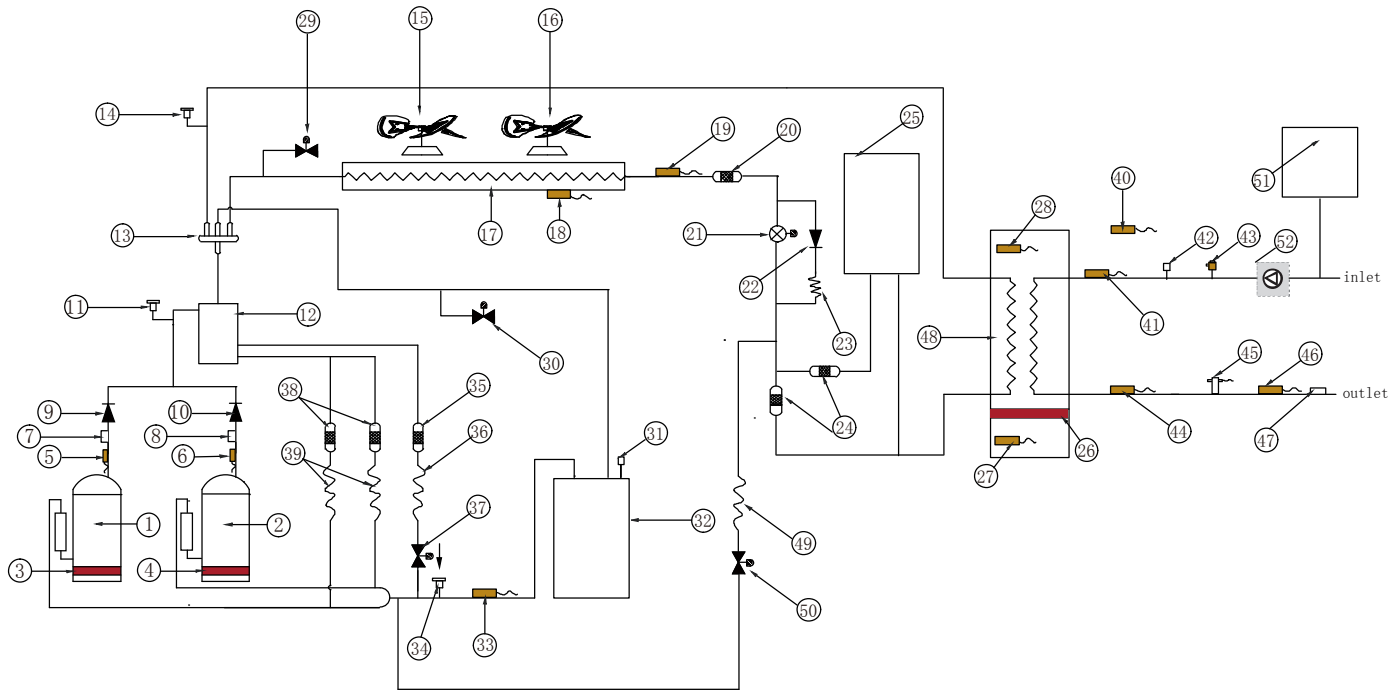

Legend			
1	DC inverter compressor 1	27	Water side antifreeze temperature sensor 2
2	DC inverter compressor 2	28	Water side antifreeze temperature sensor 1
3	Crankcase heater 1	29	Stop valve
4	Crankcase heater 2	30	Stop valve
5	DC inverter compressor discharge temperature sensor 1	31	Safety valve
6	DC inverter compressor discharge temperature sensor 2	32	Vapor-liquid separator
7	Discharge temperature control switch 1	33	Suction temperature sensor
8	Discharge temperature control switch 2	34	Low pressure switch
9	One-way valve 1	35	Filter
10	One-way valve 2	36	Capillary
11	High pressure switch	37	Fast oil return solenoid valve
12	Oil separator	38	Filter
13	4-way valve	39	Capillary
14	System pressure sensor	40	Outdoor ambient temperature sensor
15	DC fan 1	41	Unit water inlet temperature sensor
16	DC fan 2	42	Safety valve
17	Condenser	43	Air purge valve
18	Coil outlet temperature sensor	44	Unit water outlet temperature sensor
19	Coil final outlet temperature sensor	45	Water flow switch
20	Filter	46	Total outlet water temperature sensor
21	Electronic expansion valve	47	Manual water drain valve
22	One-way valve 3	48	Plater exchanger
23	Capillary	49	Capillary
24	Filter	50	Liquid injection solenoid valve
25	High pressure tank	51	Expansion tank
26	Antifreeze heater of plate heat exchanger	52	Pump

Key components:**1. Compressor**

Maintains pressure differential between high and low pressure sides of the refrigerant system.

2. Fan:

Ventilates the air side heat exchanger.

3. Oil separator:

Separates oil from gas refrigerant pumped out of the compressor and quickly returns it to the compressor. Separation efficiency is up to 99%.

4. Accumulator:

Stores liquid refrigerant and oil to protect the compressor from liquid hammering.

5. Electronic expansion valve (EXVA/B/C):

Controls refrigerant flow and reduces refrigerant pressure.

6. Four-way valve:

Controls refrigerant flow direction. Closed in cooling mode and open in heating mode. When closed, the air side heat exchanger functions as a condenser and water side heat exchanger functions as an evaporator; when open, the air side heat exchanger functions as an evaporator and water side heat exchanger function as a condenser.

7. High and low pressure switches:

Regulate refrigerant system pressure. When the refrigerant system pressure rises above the upper limit or falls below the lower limit, the high or low pressure switches turn off, stopping the compressor.

8. Discharge temperature switch:

Protects the compressor from abnormally high temperatures and transient spikes in temperature.

9. Air purge valve:

Automatically removes air from the water circuit.

10. Safety valve:

Prevents excessive water pressure by opening at 43.5psi (3bar) and discharging water from the water circuit.

11. Water flow switch:

Detects water flow rate to protect the compressor and water pump in the event of insufficient water flow.

12. Water pump:

Circulates water in the water circuit.

13. Pressure sensor:

Measures refrigerant system pressure.

14. Crankcase heater:

Prevents refrigerant from mixing with compressor oil when the compressors are stopped.

15. Water side heat exchanger electric heater:

Protects the water side heat exchanger from ice formation.

16. Water flow switch electric heater:

Provides additional heating when heating capacity provided by the heat pump is insufficient due to low ambient temperatures, it also protects external water pipes from freezing.

17. Solenoid valve SV4:

Returns oil to the compressor. It opens after 17 minutes of compressor operation, closes after 3 minutes, then opens again for 3 minutes at 17 minute increments.

18. Plate heat exchanger:

In cooling mode, it can improve super-cooling degree and the super-cooled refrigerant can achieve better heat exchange in indoor side. In heating mode, the refrigerant comes from the plate heat exchanger going to the compressor can enhance the refrigerant enthalpy and improve the heating capacity in low ambient temperature. Refrigerant volume in plate heat exchanger is controlled according to temperature different between plate heat exchanger inlet and outlet.

19. Pressure gauge joint (high and low pressure side):

Charges or discharges refrigerant.

20. Capillary:

Throttles and reduces pressure in the liquid injection cooling pipe.

21. Solenoid valve SV2:

Control the on-off of the liquid injection. It opens at the maximum discharge temperature reaching 105°C while it closes at the maximum discharge temperature below 95°C or both the maximum discharge temperature below 100°C and minimum discharge temperature below 90°C .

3 Refrigerant Flow Diagrams

Heating operation

Figure 2-3.1: Refrigerant flow during heating operation for 30kW unit

- High temperature, high press gas
- High temperature, high press liquid
- Low temperature, low pressure

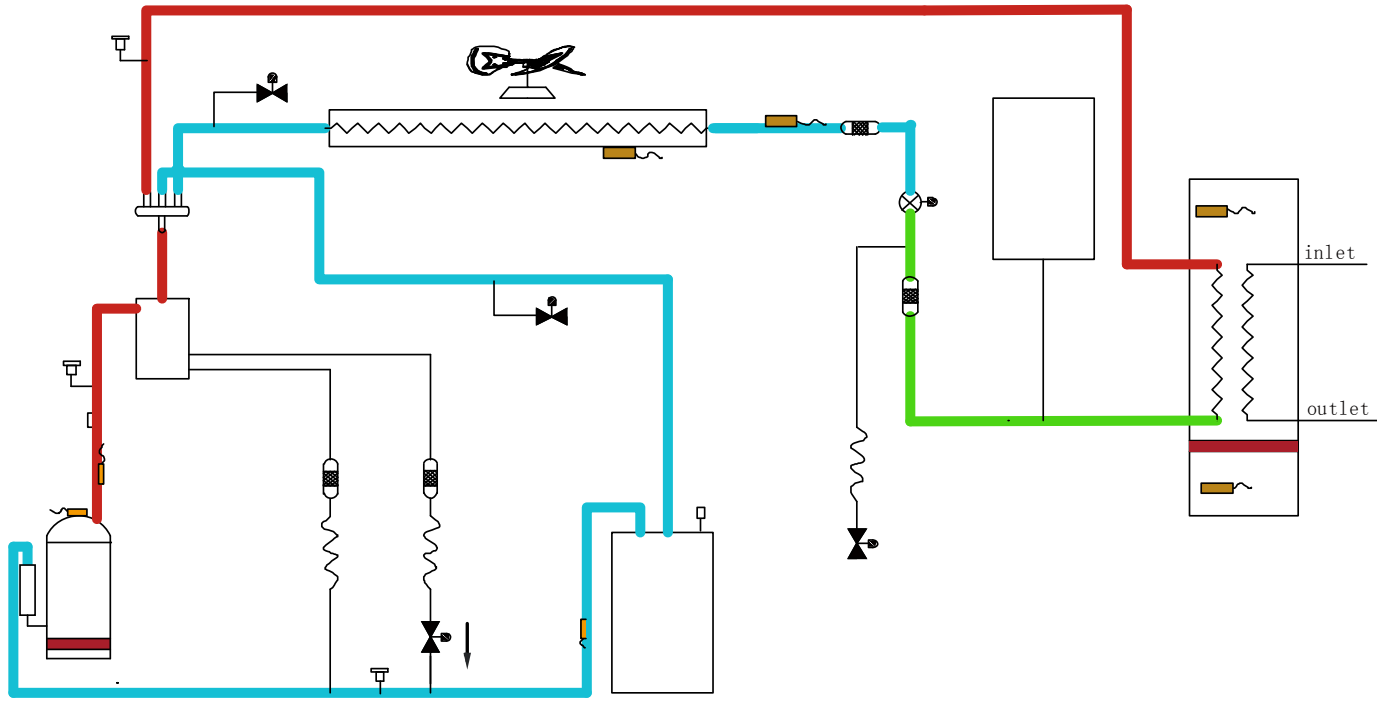
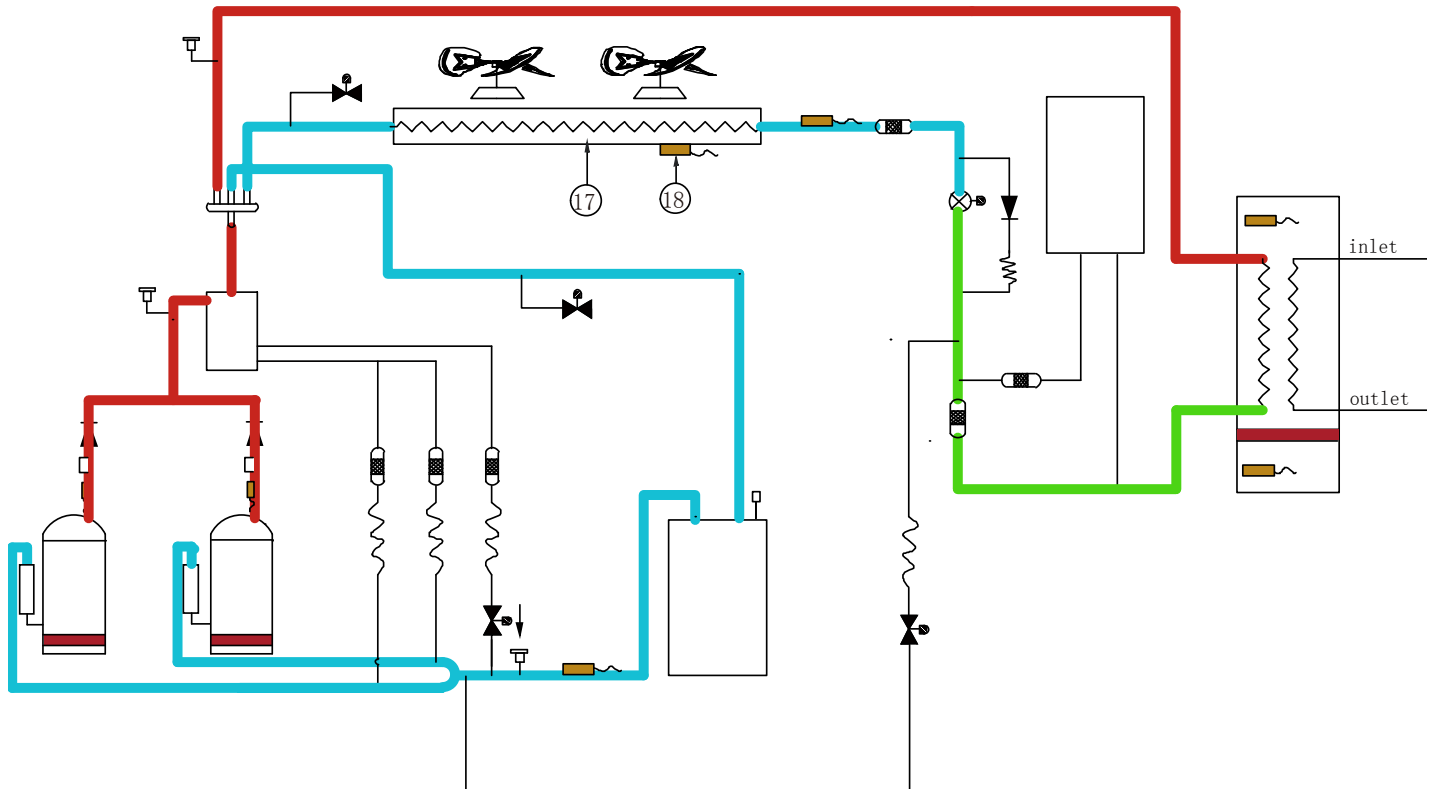

Figure 2-3.2: Refrigerant flow during heating operation for 60kW unit

- High temperature, high press gas
- High temperature, high press liquid
- Low temperature, low pressure



Cooling and defrosting operation

Figure 2-3.3: Refrigerant flow during cooling and defrosting operations for 30kW unit

- High temperature, high press gas
- High temperature, high press liquid
- Low temperature, low pressure

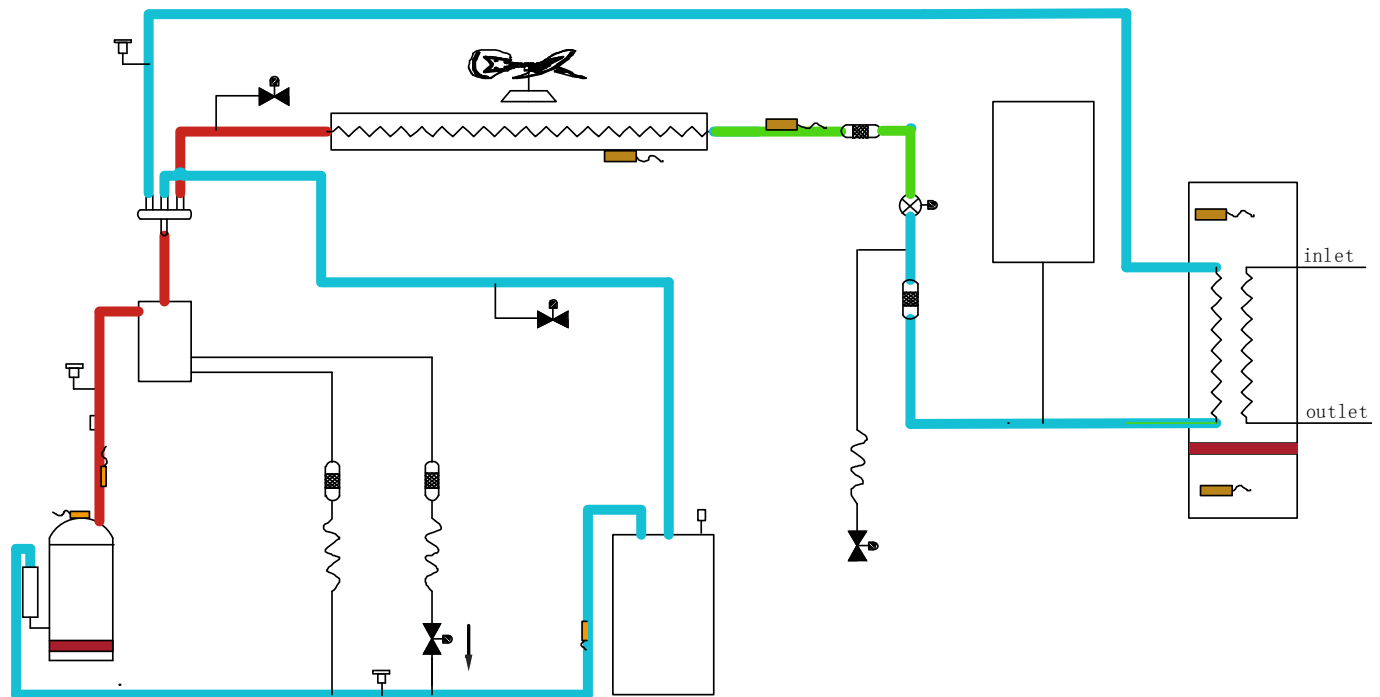
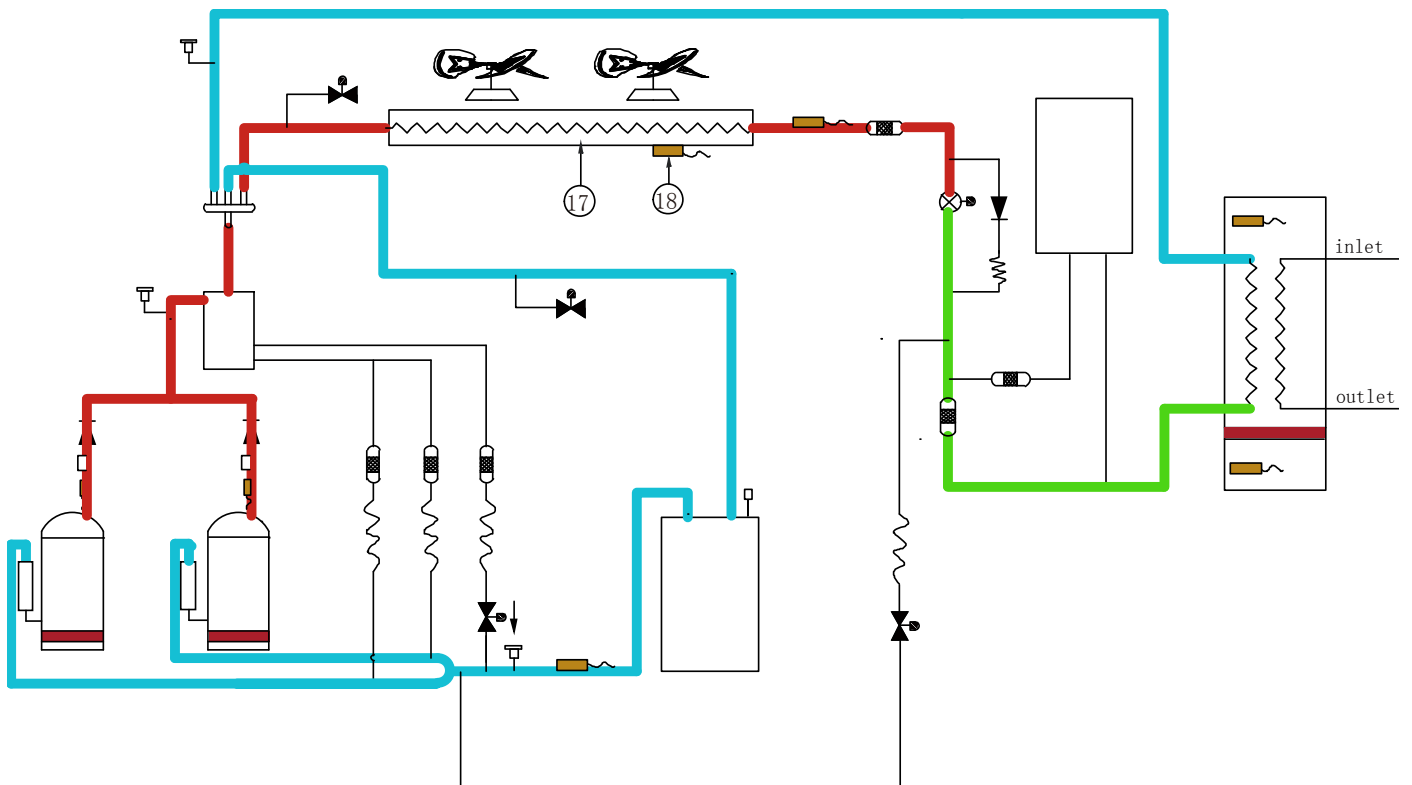

Figure 2-3.4: Refrigerant flow during cooling and defrosting operations for 60kW unit

- High temperature, high press gas
- High temperature, high press liquid
- Low temperature, low pressure



Part 3

Control

1	General Control Scheme Flowchart	24
2	Stop Operation.....	25
3	Standby Control	25
4	Startup Control.....	26
5	Normal Operation Control.....	28
6	Protection Control.....	31
7	Special Control	36

1 General Control Scheme Flowchart

Sections 3-2 to 3-7 on the following pages detail when each of the controls in the flowchart below is activated.

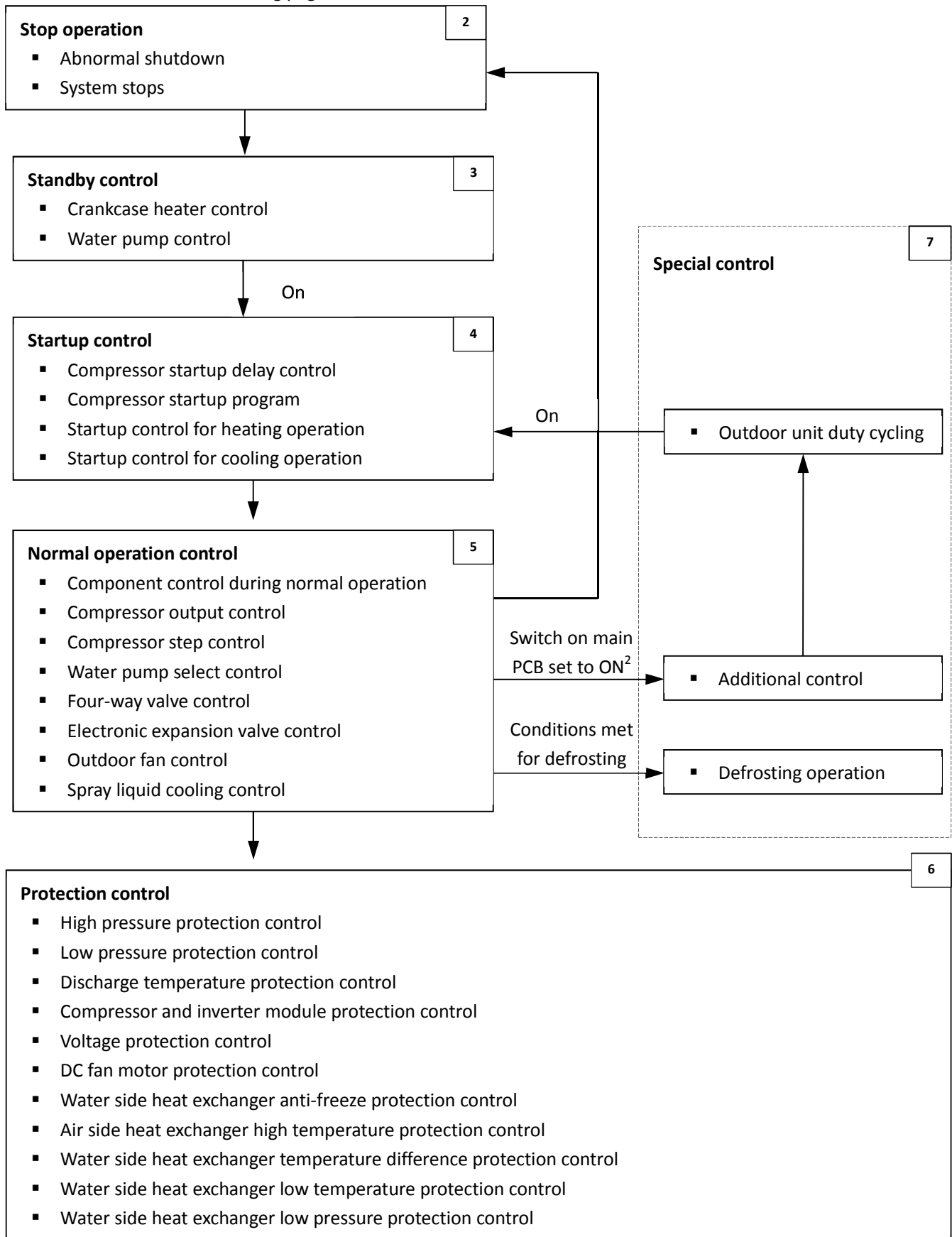

Note:

- Numbers in the top right-hand corners of boxes indicate the relevant section of text on the following pages.
- For 30kW and 60kW units is S5_3 to set additional control.

2 Stop Operation

The stop operation occurs for one of the following reasons:

1. Abnormal shutdown: in order to protect the compressors, if an abnormal state occurs the system makes a stop with thermo off operation and an error code is displayed on the outdoor unit's PCB digital displays and on the user interface.
2. The system stops when the set temperature has been reached.

3 Standby Control

3.1 Crankcase Heater Control

The crankcase heater is used to prevent refrigerant from mixing with compressor oil when the compressors are stopped. The crankcase heater is controlled according to the outdoor ambient temperature and discharge temperature. When the outdoor ambient temperature is above 40°C, the crankcase heater is off; when the outdoor ambient temperature is below 35°C, the crankcase heater is controlled according to discharge temperature. Refer to Figures 3-3.1 and 3-3.2.

Figure 3-3.1: Crankcase heater controlled according to outdoor ambient temperature

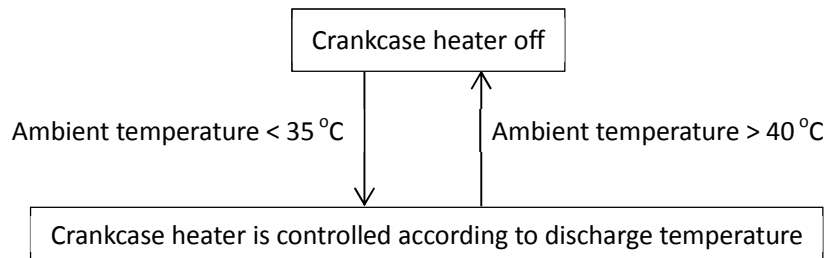
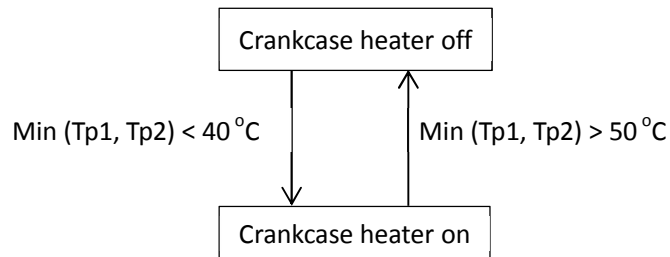

Figure 3-3.2: Crankcase heater controlled according to discharge temperature



Notes:

1. Tp1: discharge temperature sensor 1, Tp2: discharge temperature sensor 2.

3.2 Water Pump Control

When the outdoor unit is in standby, the circulator pumps run continuously.

4 Startup Control

4.1 Compressor Startup Delay Control

In initial startup control and restart control (except in defrosting operation), compressor startup is delayed such that a minimum 7 minutes has elapsed since the compressor stopped, in order to prevent frequency compressor on/off and to equalize the pressure within the refrigerant system.

4.2 Compressor Startup Program

In initial startup control and in re-start control, compressor startup is controlled according to outdoor ambient temperature and leaving water temperature. Compressor startup follows one of two startup programs until the target rotation speed is reached. Refer to Figures 3-4.1, 3-4.2, 3-4.3, 3-4.4.

Figure 3-4.1: 30kW and 60kW units compressor startup program¹ when ambient temperature is above 10°C

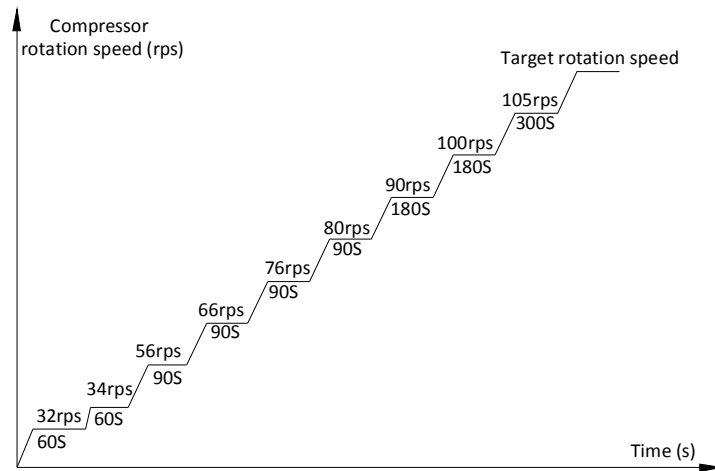

Notes:

- Once the first, 60-second stage of the program is complete, the program proceeds to the subsequent stages in a step-by-step fashion and exits when the target rotation speed has been reached.

Figure 3-4.2: 30kW and 60kW units compressor startup program¹ when ambient temperature is at or below 10°C

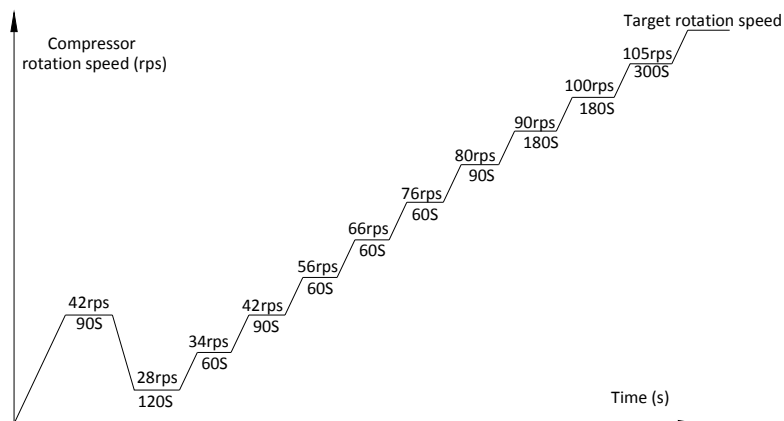

Notes:

- Once the first, 90-second stage of the program is complete, the program proceeds to the subsequent stages in a step-by-step fashion and exits when the target rotation speed has been reached.

4.3 Startup Control for Heating Operation

Table 3-4.1: Component control during startup in heating mode (30kW and 60kW units)

Component	Wiring diagram label	30kW	60kW	Control functions and states
Inverter compressor A	COMP A	●	●	Controlled according to ambient temperature and leaving water temperature ¹
Inverter compressor B	COMP B		●	
DC fan motor A	FAN A	●	●	Controlled according to ambient temperature
DC fan motor B	FAN B		●	
Electronic expansion valve	EXV-A	●	●	Position (steps) from 0 (fully closed) to 480 (fully open), controlled according to exhaust superheat.
Four-way valve	STF1	●	●	On after the compressor startup for 10s
Solenoid valve (oil balance)	SV4	●	●	Closed for 200s, open for 600s, then closed
Water pump	PUPM	●	●	On
Water side heat exchanger heater	EVA-HEAT	●	●	Off
Water flow switch	Water switch	●	●	Off
Water flow switch heater	W-HEAT	●	●	Off
Electric auxiliary heater	HEAT	●	●	Controlled according to ambient temperature and total leaving water temperature.
Crank case heater	CCH	●	●	Controlled according to ambient temperature and discharge temperature
Solenoid valve (Spray liquid cooling)	SV2	●	●	Off

Notes:

1. Refer to Figure 3-4.1, Figure 3-4.2 and in Part 3, 4.2 "Compressor Startup Program".

4.4 Startup Control for Cooling Operation

Table 3-4.2: Component control during startup in cooling mode (30kW and 60kW units)

Component	Wiring diagram label	30kW	60kW	Control functions and states
Inverter compressor A	COMP A	●	●	Controlled according to ambient temperature and leaving water temperature ¹
Inverter compressor B	COMP B		●	
DC fan motor A	FAN A	●	●	Controlled according to air side heat exchanger refrigerant total outlet temperature (Tz/7), ambient temperature and compressor speed.
DC fan motor B	FAN B		●	
Electronic expansion valve	EXV-A	●	●	Position (steps) from 0 (fully closed) to 480 (fully open), controlled according to suction superheat.
Four-way valve	STF1	●	●	Off
Solenoid valve (oil balance)	SV4	●	●	Closed for 200s, open for 600s, then closed
Water pump	PUPM	●	●	On
Water side heat exchanger heater	EVA-HEAT	●	●	Off
Water flow switch	Water switch	●	●	Off
Water flow switch heater	W-HEAT	●	●	Off
Electric auxiliary heat	HEAT	●	●	Controlled according to ambient temperature and total leaving water temperature.
Crank case heater	CCH	●	●	Controlled according to ambient temperature and discharge temperature
Solenoid valve (Spray liquid cooling)	SV2	●	●	Off

Notes:

1. Refer to Figure 3-4.1, Figure 3-4.2 and in Part 3, 4.2 "Compressor Startup Program".

5 Normal Operation Control

5.1 Component Control during Normal Operation

Table 3-5.1: Component control during heating operation (30kW and 60kW units)

Component	Wiring diagram label	30kW	60kW	Control functions and states
Inverter compressor A	COMP A	●	●	Controlled according to leaving water temperature
Inverter compressor B	COMP B		●	
DC fan motor A	FAN A	●	●	Controlled according to discharge pressure
DC fan motor B	FAN B		●	
Electronic expansion valve	EXV-A	●	●	Position (steps) from 0 (fully closed) to 480 (fully open), controlled according to exhaust superheat.
Four-way valve	STF1	●	●	On
Solenoid valve (oil balance)	SV4	●	●	Open for 3min every 2min
Water pump	PUPM	●	●	On
Water side heat exchanger heater	EVA-HEAT	●	●	Off
Water flow switch	Water switch	●	●	Off
Water flow switch heater	W-HEAT	●	●	Off
Electric auxiliary heater	HEAT	●	●	Controlled according to ambient temperature and total leaving water temperature.
Crank case heater	CCH	●	●	Controlled according to ambient temperature and discharge temperature
Solenoid valve (Spray liquid cooling)	SV2	●	●	Opens when exhaust temperature over 105°C

Table 3-5.2: Component control during cooling operation (30kW and 60kW units)

Component	Wiring diagram label	30kW	60kW	Control functions and states
Inverter compressor A	COMP A	●	●	Controlled according to leaving water temperature
Inverter compressor B	COMP B		●	
DC fan motor A	FAN A	●	●	Controlled according to air side heat exchanger refrigerant total outlet temperature (Tz/7)
DC fan motor B	FAN B		●	
Electronic expansion valve	EXV-A	●	●	Position (steps) from 0 (fully closed) to 480 (fully open), controlled according to suction superheat.
Four-way valve	STF1	●	●	Off
Solenoid valve (oil balance)	SV4	●	●	Open for 3min every 2min
Water pump	PUPM	●	●	On
Water side heat exchanger heater	EVA-HEAT	●	●	Off
Water flow switch	Water switch	●	●	Off
Water flow switch heater	W-HEAT	●	●	Off
Electric auxiliary heater	HEAT	●	●	Controlled according to ambient temperature and total leaving water temperature.
Crank case heater	CCH	●	●	Controlled according to ambient temperature and discharge temperature
Solenoid valve (Spray liquid cooling)	SV2	●	●	Opens when exhaust temperature over 105°C

5.2 Compressor Output Control

The compressor rotation speed is controlled according to the load requirement. Before compressor startup, the outdoor unit determines the compressor target speed according to outdoor ambient temperature, discharge temperature and then runs the appropriate compressor startup program. Refer to Part 3, 4.2 “Compressor Startup Program”. Once the startup program is complete, the compressor runs at the target rotation speed.

The compressor speed is controlled according to two parts in normal operation:

In cooling mode: In a single system, the compressor speed is controlled according to the water outlet temperature and

water outlet setting temperature. In a combination system, the compressor of master unit is controlled according total water outlet temperature and water outlet setting temperature, the compressor of the slave unit is controlled according to water inlet and water outlet temperature. Both in a single system and combination system, the compressor speed is limited by the inverter module temperature (Tf), ambient temperature, discharge temperature and air side heat exchanger refrigerant total outlet temperature (Tz/7).

In heating mode: In a single system, the compressor speed is controlled according to the water outlet temperature and water outlet setting temperature. In a combination system, all compressors are controlled according to the total water outlet temperature and the water outlet setting temperature. Both in a single system and combination system, the compressor speed is limited by inverter module temperature (Tf), ambient temperature, discharge temperature, discharge pressure.

5.3 Compressor Step Control

The running speed of six-pole compressors in rotations per second (rps) is one third of the frequency (in Hz) of the electrical input to the compressor motor. The frequency of the electrical input to the compressor motors can be altered at a rate of 1Hz in two seconds.

5.4 Water pump select control

For 30kW and 60kW units model

When the dial switch S12_2 on the main PCB is switched ON, the system runs “one small pump per unit” mode, when S12_2 is switched OFF, the system runs “one large pump controlled by master unit” mode.

- One pump control: only the master unit output pump signal, no pump signal output on the slave units.
- Multiple pump control: output pump signal on all units.
- S12_2 in one system must be switched to the same position or not error code FP_ will be displayed.

5.5 Four-way Valve Control

The four-way valve is used to change the direction of refrigerant flow through the water side heat exchanger in order to switch between cooling and heating operations. Refer to Figures 2-3.1 ,2-3.2, 2-3.3, 2-3.4, 2-3.5 in Part 2, 3 “Refrigerant Flow Diagrams”.

During heating operation, the four-way valve is on; during cooling and defrosting operation, the four-way valve is off.

5.6 Electronic Expansion Valve Control

For 30kW and 60kW units model

The position of the electronic expansion valve (EXV) is controlled in steps from 0 (fully closed) to 480 (fully open).

- At power-on:
- The EXV first closes fully, then moves to the standby position (352 (steps)). After 30seconds the EXV moves to an initial running position, which is determined according to the operating mode and outdoor ambient temperature.
- When the unit operate in cooling mode, after 60 seconds, the EXV is controlled according to suction superheat, water inlet temperature and compressor frequency.
- When the unit operates in heating mode, after a further 60 seconds, the EXV is controlled according to discharge superheat and compressor frequency, and uses the suction temperature, air side heater exchanger temperature, discharge temperature to modify the control.
- When the outdoor unit is in standby:
 - The EXV is at position 352 (steps).

- When the outdoor unit stops:
 - The EXV first closes fully, then moves to the standby position (352 (steps)).

5.7 Outdoor Fan Control

The speed of the outdoor unit fan(s) is adjusted in steps, as shown in Table 3-5.3.

Table 3-5.3: Outdoor fan speed steps for (30kW and 60kW units)

Fan speed index	Fan speed (rpm)		
	30kW	60kW	
	FAN A	FAN A	FAN B
0	0	0	0
1	150	0	150
2	170	0	190
3	190	0	210
4	210	0	230
5	230	0	250
6	250	150	150
7	270	150	170
8	290	150	190
9	310	170	190
10	330	210	190
11	350	230	210
12	370	250	230
13	400	270	250
14	430	290	270
15	60	310	290
16	490	330	310
17	520	350	330
18	550	370	350
19	580	400	370
20	610	430	400
21	640	470	430
22 (super silent mode)	670	510	470
23	700	550	510
24	720	600	550
25(silent mode)	740	650	600
26	760	700	650
27	780	750	700
28	780	800	750
29	800	830	800
30	800	850	830
31	820	870	850
32(standard mode)	820	890	870

5.8 Spray liquid cooling control

When the discharge temperature of compressor exceeds 105°C , the solenoid valve opens and the discharge temperature reduces. When the discharge temperature is below 90°C , the solenoid valve closes.

6 Protection Control

6.1 High Pressure Protection Control

This control protects the refrigerant system from abnormally high pressure and protects the compressor from transient spikes in pressure.

Figure 3-6.1: High pressure protection control for 30kW and 60kW units

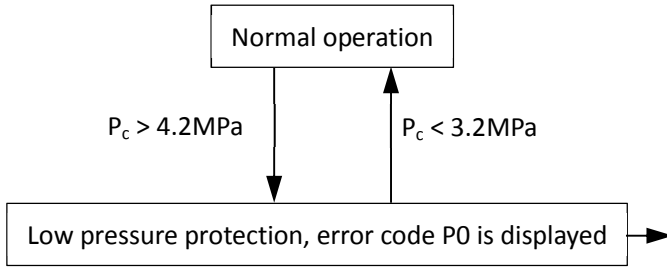

Notes:

1. P_c : Discharge pressure

When P0 protection occurs 3 times in 60 minutes, a manual system restart is required before the system can resume operation.

When the discharge pressure rises above 4.2MPa the system displays P0 protection and all units stop running. When the discharge pressure drops below 3.2MPa, the compressor enters re-start control.

6.2 Low Pressure Protection Control

This control protects the refrigerant system from abnormally low pressure and protects the compressor from transient drops in pressure.

Figure 3-6.2: Low pressure protection control for 30kW and 60kW units

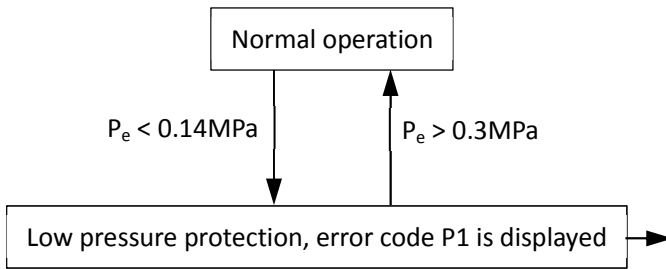

Notes:

1. P_e : Suction pressure

When P1 protection occurs 3 times in 60 minutes, manual system restart is required before the system can resume operation.

When the suction pressure drops below 0.14MPa the system displays P1 protection and all the units stop running. When the suction pressure rises above 0.3MPa, the compressor enters re-start control.

6.3 Discharge Temperature Protection Control

This control protects the compressor from abnormally high temperatures and transient spikes in temperature.

Figure 3-6.3: High discharge temperature protection control for 30kW and 60kW units

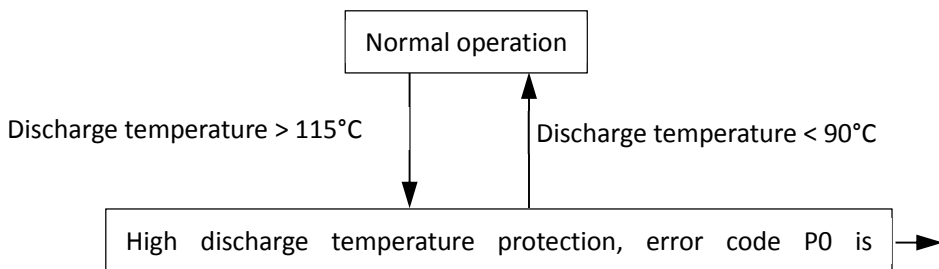

When P0 protection occurs 3 times in 60 minutes, a manual system restart is required before the system can resume operation.

When the discharge temperature rises above 115°C the system displays P0 protection and all the units stop running. When the discharge temperature drops below 90°C, the compressor enters re-start control.

6.4 Compressor and Inverter Module Protection Control

This control protects the compressors from abnormally high currents and protects the inverter modules from abnormally high temperatures. It is performed for each compressor and inverter module.

Figure 3-6.4: Compressor current protection control for 30kW and 60kW units

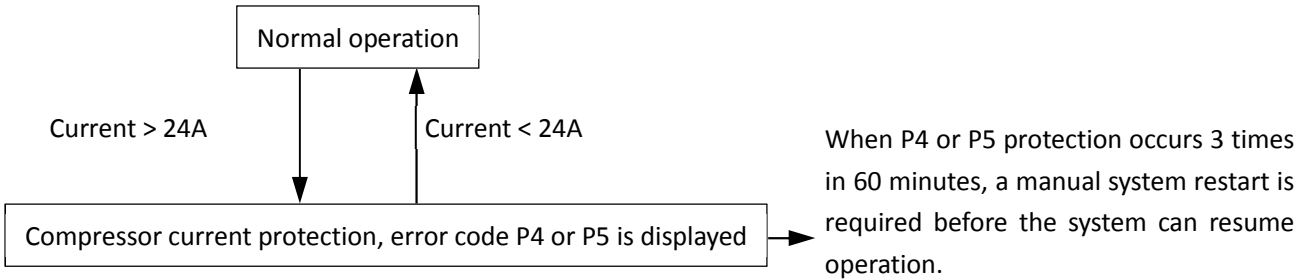

Notes:

1. P4 is the protection for the power supply phase B, P5 is the protection for the power supply phase C.

When the compressor current rises above 24A, the system displays P4 or P5 protection and all the units stop running. When the compressor current drops below 24A, the compressor enters re-start control.

Figure 3-6.5: Inverter module temperature protection control for 30kW and 60kW units

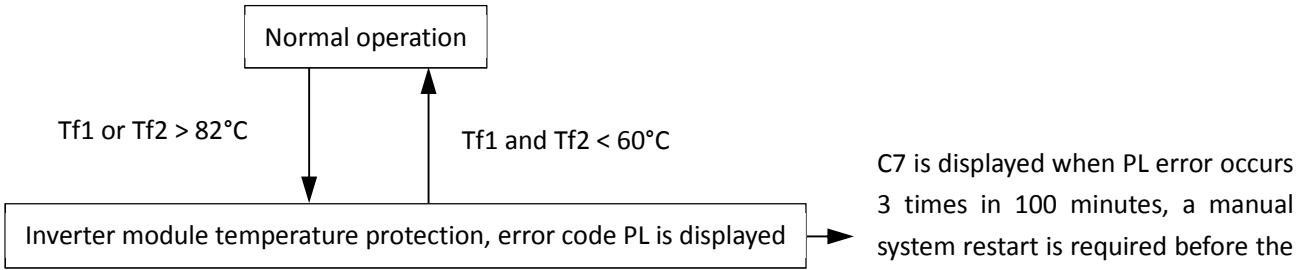

Notes:

1. Tf1:Heat sink temperature 1; Tf2:Heat sink temperature 2

When the Tf1 or Tf2 temperature rises above 82°C, the system displays PL protection and all the units stop running. When the Tf1 and Tf2 temperature drops below 60°C, the compressor enters re-start control.

6.5 Voltage Protection Control

This control protects the units from abnormally high or abnormally low voltages.

Figure 3-6.6: Compressor voltage protection control

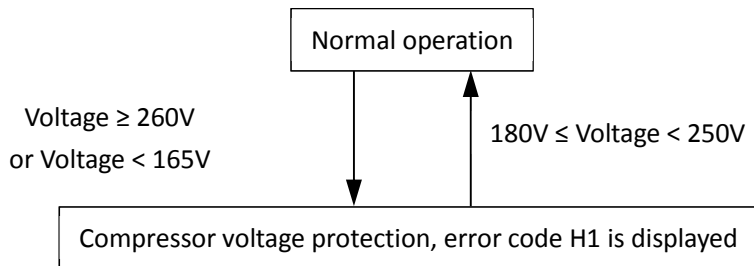

When the phase voltage of AC power supply is at or above 260V for more than 30 seconds, the system displays H5 protection and all the units stop running. When the phase voltage drops below 250V for more than 30 seconds, the units restart once the compressor re-start delay has elapsed. When the phase voltage is below 165V for more than 30 seconds, the system displays H5 protection and all the units stop running. When the AC voltage rises to at or above 180V for more than 30 seconds, the refrigerant system restarts once the compressor re-start delay has elapsed.

6.6 DC Fan Motor Protection Control

This control protects the DC fan motors from abnormal power supply. DC fan motor protection occurs when the fan module does not receive any feedback from the fan motor.

When DC fan motor protection control occurs the system displays the PU error code and the unit stops running. When PU protection occurs 2 times in 120 minutes, the FF error is displayed. When an FF error occurs, a manual system restart is required before the system can resume operation.

6.7 Water Side Heat Exchanger Anti-freeze Protection Control

This control protects the water side heat exchanger from ice formation. The water side heat exchanger electric heater is controlled according to water side heat exchanger anti-freezing temperature (Taf), water inlet temperature (Twi), water outlet temperature (Two) and total water outlet temperature (Tw).

When water side heat exchanger anti-freeze protection occurs the system displays error code Pb and all the units stop running.

Figure 3-6.7: Anti-freeze protection control in normal cooling mode

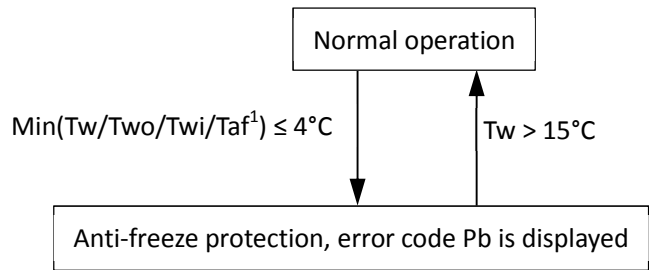

Note:
1. Taf include Taf1 and Taf2.

In standby or normal cooling mode, either water side heat exchanger anti-freezing temperature (Taf), water inlet temperature (Twi), water outlet temperature (Two) or total water outlet temperature (Tw) is below 4°C, the unit will run heating mode, until the total water outlet temperature is above 15°C, and restart the normal operation.

Figure 3-6.8: Anti-freeze protection control in low water outlet cooling mode

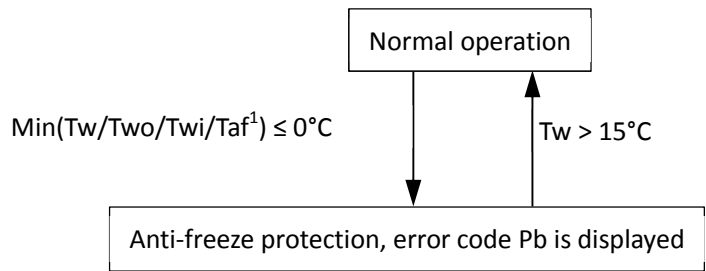

Note:
1. Taf include Taf1 and Taf2.

In low water outlet cooling mode, either water side heat exchanger anti-freezing temperature (Taf), water inlet temperature (Twi), water outlet temperature (Two) or total water outlet temperature (Tw) is below 0°C, the unit will run heating mode, until the total water outlet temperature is above 15°C, and restart the normal operation.

6.8 Air Side Heat Exchanger High Temperature Protection Control

This control protects the air side heat exchanger from high temperature.

Figure 3-6.9: Air side heat exchanger high temperature protection control ¹

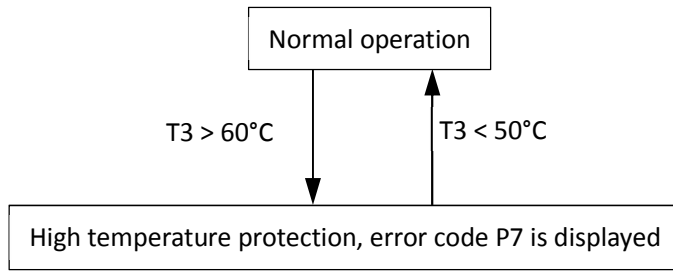

Note:

- 1. T3: Air side heat exchanger refrigerant outlet temperature

When the air side heat exchanger refrigerant outlet temperature (T3) rises above 60°C, the system displays P7 protection and all the units stop running. When the air side heat exchanger refrigerant outlet temperature (T3) drops below 50°C, the compressor enters re-start control.

Figure 3-6.10: Air side heat exchanger temperature protection control ²

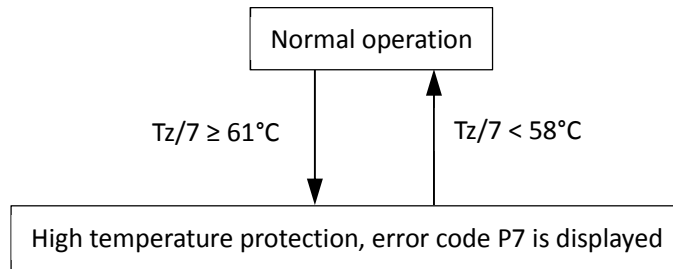

Note:

- 1. Tz/7: Air side heat exchanger refrigerant total outlet temperature

When the air side heat exchanger refrigerant total outlet temperature (Tz/7) temperature rises at or above 61°C, the system displays P7 protection and the unit stops running. When the air side heat exchanger refrigerant total outlet temperature (Tz/7) temperature drops below 58°C, the compressor enters re-start control.

6.9 Water Side Heat Exchanger Temperature Difference Protection Control

This control protects the water side heat exchanger from ice formation.

Figure 3-6.11: Water side heat exchanger temperature difference protection control

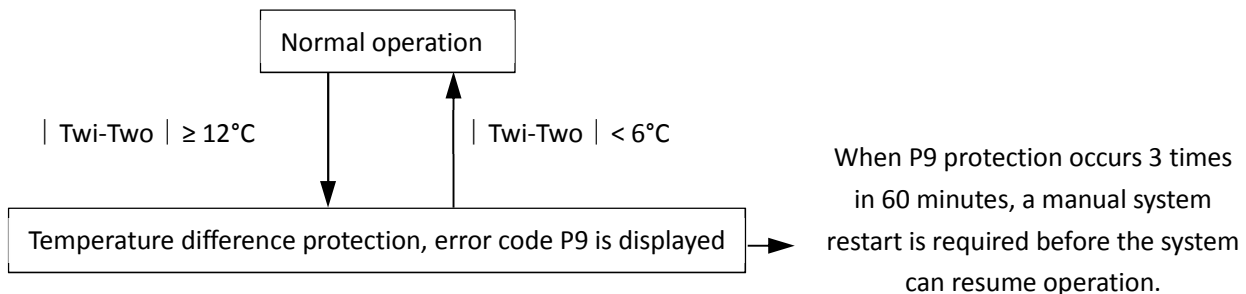

Notes:

- 1. Twi: Water side heat exchanger inlet temperature
- 2. Two: Water side heat exchanger outlet temperature

When the temperature difference rises at or above 12°C, the system displays P9 protection and all the units stop running. When the Temperature difference drops below 6°C, the compressor enters re-start control.

6.10 Water Side Heat Exchanger Low Temperature Protection Control

This control protects the water side heat exchanger from ice formation.

Figure 3-6.12: Water side heat exchanger low temperature protection control in normal cooling mode

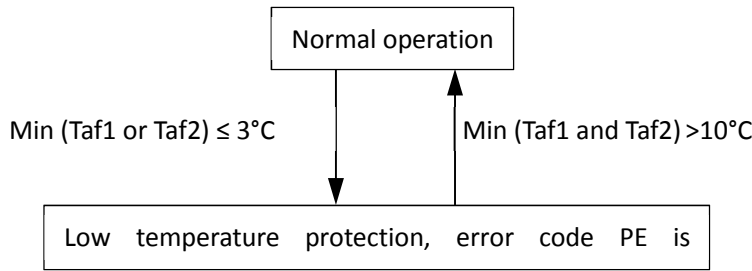

Notes:

1. Taf1: Water side heat exchanger anti-freezing temperature1
2. Taf2: Water side heat exchanger anti-freezing temperature2

When water side heat exchanger anti-freezing temperature1 (Taf1) or water side heat exchanger anti-freezing temperature2 (Taf2) is at or below 3°C for more than 3 seconds, the system displays PE protection and the corresponding unit stop running. When water side heat exchanger anti-freezing temperature1 (Taf1) and Water side heat exchanger anti-freezing temperature2 (Taf2) rise to 10°C or higher, the compressor enters re-start control. Use the user interface to clear the error.

Figure 3-6.13: Water side heat exchanger low temperature protection control in low outlet water mode

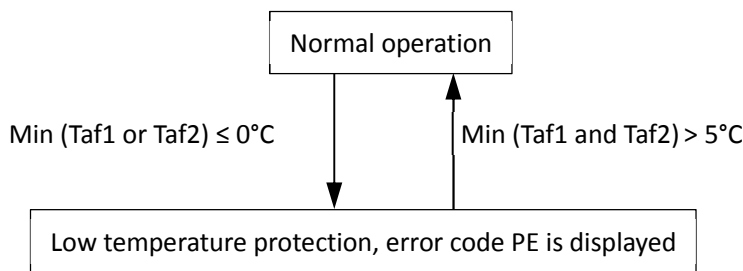

When water side heat exchanger anti-freezing temperature1 (Taf1) or water side heat exchanger anti-freezing temperature2 (Taf2) is at or below 0°C for more than 3 seconds, the system displays PE protection and orders the corresponding units to stop running. When water side heat exchanger anti-freezing temperature1 (Taf1) and Water side heat exchanger anti-freezing temperature2 (Taf2) rise to 5°C or higher, the compressor enters re-start control. Use the user interface to clear the error.

6.11 Water Side Heat Exchanger Low Pressure Protection Control

This control protects the water side heat exchanger from ice formation.

Figure 3-6.14: Water side heat exchanger low pressure protection control in normal cooling mode

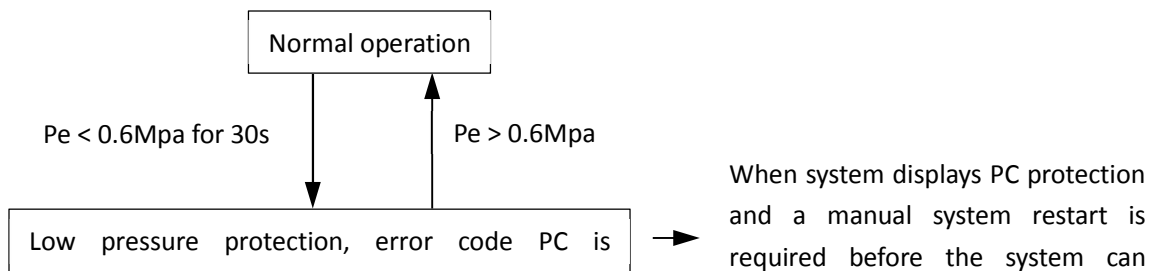

Notes:

1. Pe: Suction pressure

In normal cooling mode, when the suction pressure drops below 0.6Mpa for 30s, the system displays PC protection and all

the units stop running. When the suction pressure is above 0.6Mpa, the compressor enters re-start control. It will not display the PC error when the suction pressure drops below 0.6Mpa for 30s for the first time until the suction pressure drops below 0.6Mpa for 30s for the second time in 30 minutes.

Figure 3-6.15: Water side heat exchanger low pressure protection control in low outlet water cooling mode

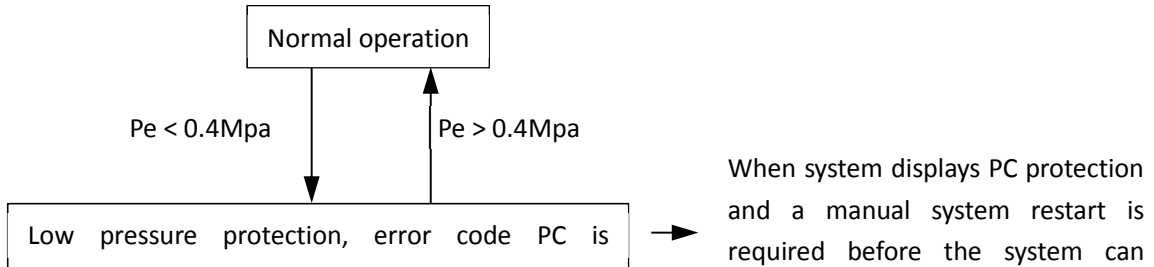

Note:
1. Pe: Suction pressure

In low outlet water cooling mode, when the suction pressure drops below 0.4Mpa, the system displays PC protection and all the units stop running. When the suction pressure is above 0.4Mpa, the compressor enters re-start control. It will not display the PC error when the suction pressure drops below 0.4Mpa for the first time until the suction pressure drops below 0.4Mpa for the second time in 30 minutes.

7 Special Control

7.1 Outdoor Unit Duty Cycling

In systems with multiple outdoor units, outdoor unit duty cycling is used to balance the compressor running time. Outdoor unit duty cycling occurs whenever all the outdoor units stop running (either because the leaving water set temperature has been reached or because a master unit error has occurred):

- When the outdoor units are powered on for the first time, if there is a load requirement, the units turn on, starting with the master unit. As the leaving water temperature approaches its set temperature, units shut down in succession, starting with the unit with the highest address. Once the set temperature has been reached, the master unit shuts down.
- The next time a load requirement exists (or, following a master unit error), the units turn on, starting with the unit with the highest address. As the leaving water temperature approaches its set temperature, units shut down in succession, starting with the unit with the lowest address (the master unit). Once the set temperature has been reached, the unit with the highest address shuts down.

Figure 3-7.1 shows an example of duty cycling in a system with 16 outdoor units.

Figure 3-7.1: Duty cycling in a system with 16 outdoor units¹

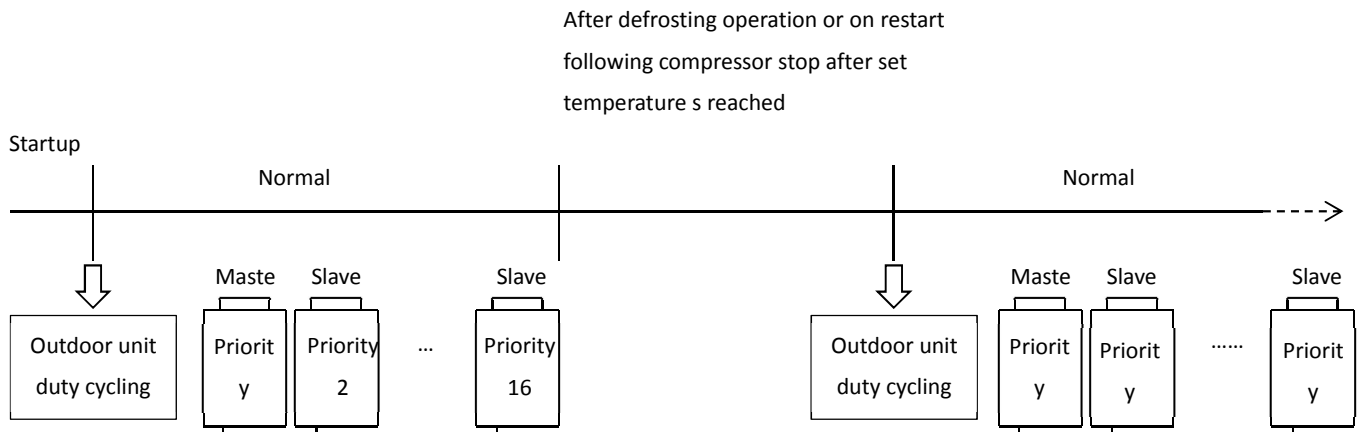

Notes:
1. The address settings on the outdoor unit main PCBs for master unit and slave unit do not change.

7.2 Defrosting Operation

In order to recover heating capacity, the defrosting operation is conducted when the outdoor unit air side heat exchanger is performing as a condenser. The defrosting operation is controlled according to outdoor ambient temperature, air side heat exchanger refrigerant outlet temperature and the compressor running time.

The defrosting operation ceases when any one of the following three conditions occurs:

- Defrosting operation duration reaches 10 minutes.
- The air side heat exchanger refrigerant outlet temperature reaches the target temperature.
- The water outlet temperature is at or below 5°C.

Table 3-7.1: Component control during defrosting operation for 30kW and 60kW units

Component	Wiring diagram label	30kW	60kW	Control functions and states
Inverter compressor A	COMP A	●	●	Controlled according to leaving water temperature
Inverter compressor B	COMP B		●	
DC fan motor A	FAN A	●	●	Off
DC fan motor B	FAN B		●	
Electronic expansion valve	EXV-A	●	●	480p
Four-way valve	STF1	●	●	Off
Solenoid valve (oil balance)	SV4	●	●	Open
Water pump	PUPM1	●	●	On
Water side heat exchanger heater	EVA-HEAT	●	●	Off
Water flow switch	/	●	●	Off
Water flow switch heater	W-HEAT1	●	●	Controlled according to ambient temperature, water inlet temperature and water outlet temperature
Electric auxiliary heater	HEAT	●	●	Controlled according to ambient temperature and total water outlet temperature after the compressor is on
Crank case heater	CCH	●	●	Controlled according to ambient temperature and discharge temperature
Solenoid valve (Spray liquid cooling)	SV2	●	●	Controlled according to discharge temperature

7.3 Additional control

When dial switch S5_3 on main PCB is switched ON, additional control is valid, connect a controller or not is permissible.

When dial switch S5_3 is switched OFF, additional control is invalid. This function is only valid on the master unit.

When dial switch S5_3 is switched ON and disconnect a wired controller:

- The system ON/OFF state is controlled by the ON/OFF port (CN8 on the main PCB). Connecting this port, system on, disconnecting this port, system off.
- The mode of the system is controlled by the Cool/Heat port (CN8 on the main PCB). Connecting this port, system running heating mode, disconnecting this port, system running cooling mode.
- The default water outlet temperature setting in heating mode is 45°C and in cooling mode is 7°C. The default hysteresis temperature setting is 2°C.
- The network icon on the wired controlled flashes, frequency and “rctc” alternate display on main PCB .

When dial switch S5_3 is switched ON and connect a wired controller, the water outlet temperature and hysteresis temperature can be set by the wired controller.

Part 4

Diagnosis and Troubleshooting

1	Outdoor Unit Electric Control Box Layout.....	40
2	Outdoor Unit PCBs.....	42
3	Error Code Table	51
4	Troubleshooting	54
5	Appendix to Part 5.....	113

1 Outdoor Unit Electric Control Box Layout

30kW unit

Figure 4-1.1: Electric control box front view- top layer

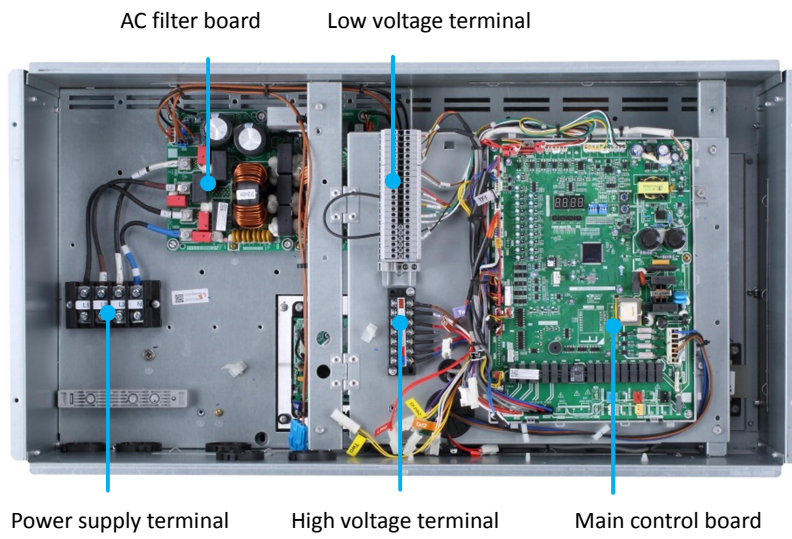
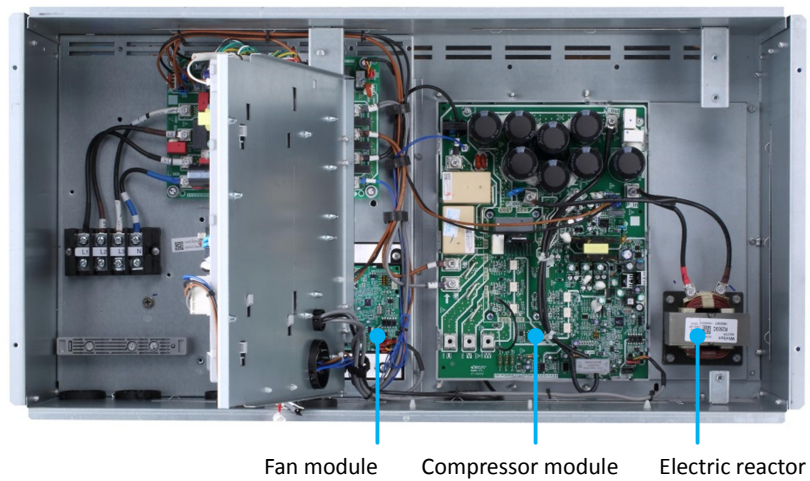

Figure 4-1.2: Electric control box front view-bottom layer



60kW unit

Figure 4-1.3: Electric control box front view-top layer

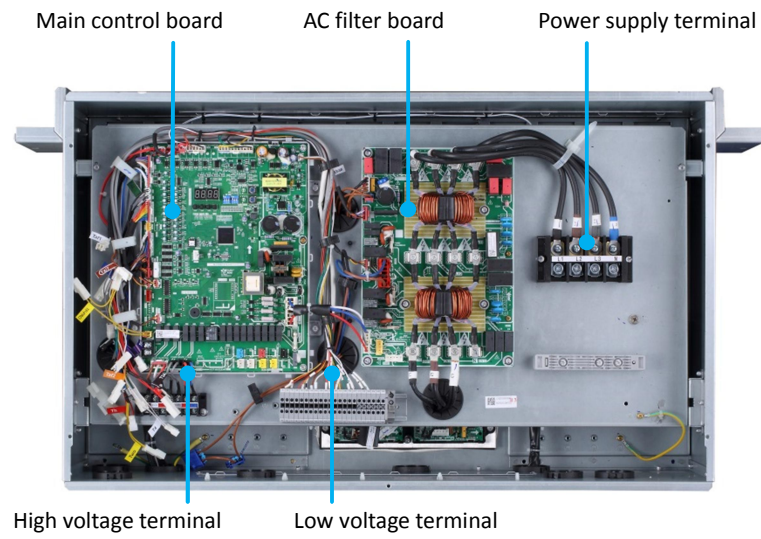
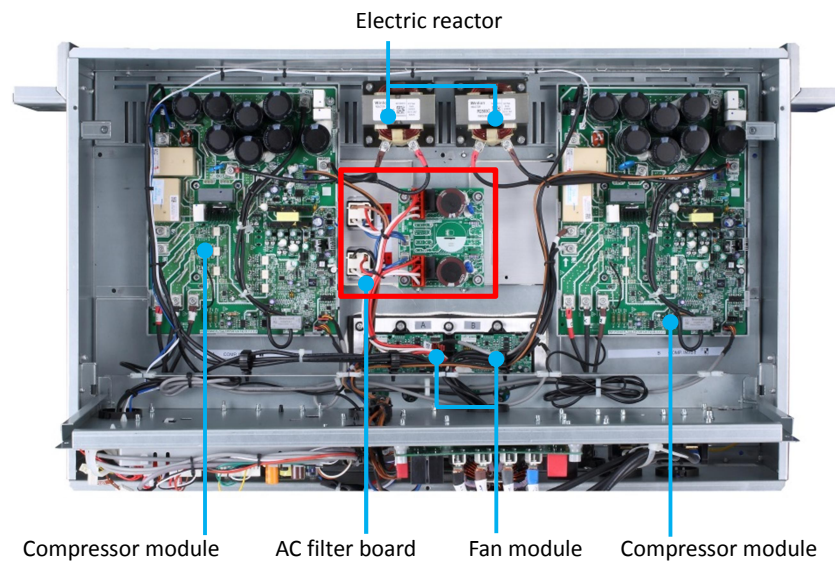

Figure 4-1.4: Electric control box side view-bottom layer



2 Outdoor Unit PCBs

2.1 Types

Aqua Tempo Super II units have four PCBs – main control board, three phase AC filter board, DC fan inverter module board and compressor inverter module board.

In addition to the four PCBs, 30kW unit each has one board while 60kW unit have one main control board and the other boards each has two boards.

The locations of each PCB in the outdoor unit electric control boxes are shown in Figures 4-1.1 to 4-1.4 in Part 4, 1 “Outdoor Unit Electric Control Box Layout”.

2.2 Main PCB

Figure 4-2.1: Outdoor unit main PCB for 30kW and 60kW units

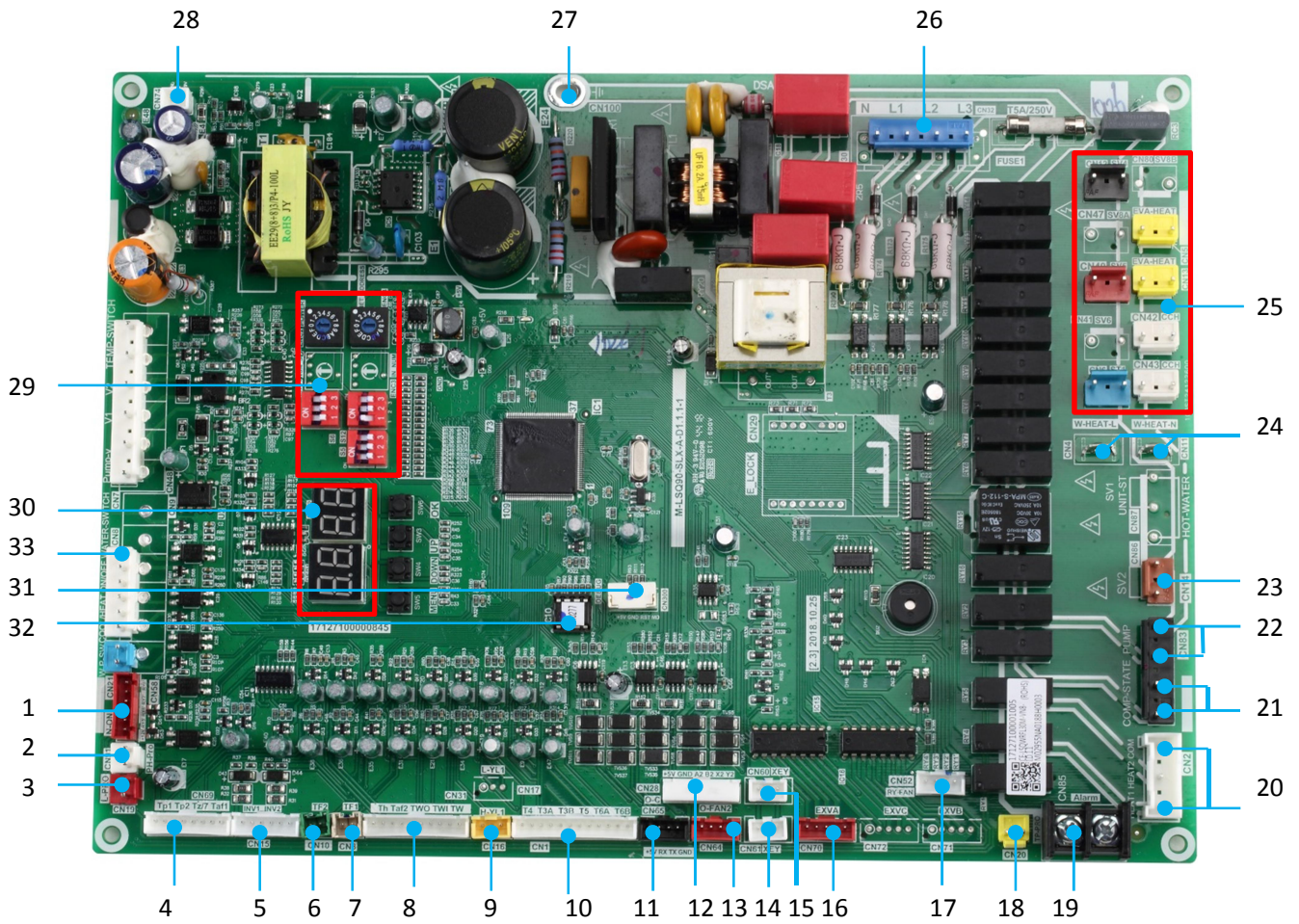

Note:

1. Label descriptions are given in Table 4-2.1

Table 4-2.1: Outdoor unit main PCB for 30kW and 60kW units

Label in Figure 4-2.1	Code	Content	Voltage
1	CN21	Signal output port for filter board relay	0 or 12V DC
2	CN91	Reserve port	0 or 12V DC
3	CN19	ON/OFF signal input port for system low pressure	0 or 5V DC
4	CN69	Temperature detection port (Tp1/Tp2/Tz/7/Taf1)	0~5V DC
5	CN15	Current inspection port of the inverter compressor A、 compressor B	0~5V DC
6	CN10	Heatsink temp. detection port of inverter module B	0~5V DC
7	CN3	Heatsink temp. detection port of inverter module A	0~5V DC
8	CN31	Temperature detection port (Th/Taf2/Two/Twi/Tw)	0~5V DC
9	CN16	Input port for system high pressure detection	0~5V DC
10	CN1	Temperature detection port (T4/T3A/T3B/T5/T6A/T6B)	0~5V DC
11	CN65	Communication port between Main board and compressor inverter module	0~5V DC
12	CN28	Connection port of auxiliary board (Reserve)	0~5V DC
13	CN64	Communication port between Main board and fan inverter module	0~5V DC
14	CN61	Communication port between main board and HMI	0~5V DC
15	CN60	Communication port between outdoor units	0~5V DC
16	CN70	Actuation port of EXV A	0 or 12V DC
17	CN52	Signal output port for filter board relay	0 or 12V DC
18	CN20	ON/OFF signal input port for system discharge temperature	0 or 12V DC
19	CN85	Output port for alarm	0 or 230V AC
20	CN2	Output port for auxiliary heater of pipeline	0 or 230V AC
21	CN83	Output port for compressor state	0 or 230V AC
22	CN83	Output port for pump	0 or 230V AC
23	CN14	Output port for valve SV2	0 or 230V AC
24	CN4 CN11	Output port for electrical heater of water switch	0 or 230V AC
25	CN5 CN13 CN42 CN43 CN6 CN41 CN40 CN47 CN12 CN80	Output port for valve and electrical heater of crankcase and plate exchanger	0 or 230V AC
26	CN32	Input of three-phase four-wire power supply	L1&N: 230V AC L2&N: 230V AC L3&N: 230V AC
27	CN100	PE port	0V AC
28	CN74	The power supply port of the HMI (DC9V)	9V DC
29	ENC2 ENC4 S5 S6 S12	Out setting switch	0 or 5V DC

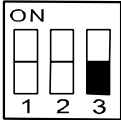
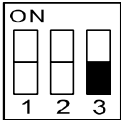
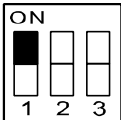
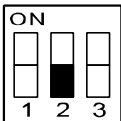
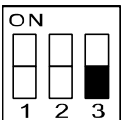

Table continued on next page.....

Table 4-2.1: Outdoor unit main PCB for 30kW and 60kW units

30	DSP1 DSP2	Digital tube display	0 or 5V DC
31	CN300	Program burn in port(WizPro200RS programming device)	-
32	IC10	EEPROM	5V DC
33	CN8	Port for water flow switch	0 or 12V DC

2.2.1 Main PCB field setting

Table 4-2.2: Main PCB switch settings for 30kW and 60kW units

Switch	Description	Default factory setting
S5-3 	Normal control	OFF
	Remote control	-
S6-3 	Anti-snow function is invalid	OFF
	Anti-snow function is effective	-
S12-1 	Represent Media product	ON
S12-2 	Single water pump control	OFF
	Multiple water pumps control	-
S12-3 	Normal cooling mode	OFF
	Low-temperature cooling mode	-
ENC2 	DIP switch of outdoor unit capacity	0: MC-SU30-RN8L 1: MC-SU60-RN8L
ENC4 	DIP switch of outdoor unit network address 0: master unit 1,2,3...F: slave units	0

Note:

1. Low water outlet temperature range: 0°C to 20°C; normal water outlet temperature range: 5°C to 20°C.
2. When using ON/OFF function, first is to dial the S5-3 switch and then short circuit the terminal on the main PCB. The operation method is as follows:
Remote off: dial S5-3 to ON
Remote cool: dial S5-3 to ON and short circuit the additional control terminal
Remote heat: dial S5-3 to ON and short circuit the additional control terminal and cool/heat terminal.

2.2.2 Function of buttons SW3 to SW6

Table 4-2.3: Function of buttons SW3 to SW6 for 30kW and 60kW units

Button	Function
SW3	Up
SW4	Down
SW5	Menu
SW5	Ok

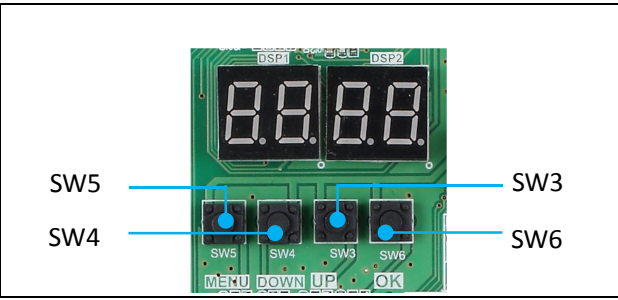

2.2.3 Digital display output

Table 4-2.4: Digital display output in different operating states for 30kW and 60kW units

Outdoor unit state		Parameters displayed on DSP1	Parameters displayed on DSP2
Standby		0	1
Normal operation	For single compressor units	None	Running speed of compressor
	For dual compressor units	Running speed of compressor A in rotations per second	Running speed of compressor B in rotations per second
Error or protection		-- or placeholder	Error or protection code

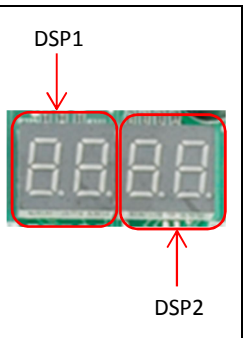

2.3 Compressor Inverter Module Board

Figure 4-2.2: Compressor inverter module PCB for 30kW and 60kW units

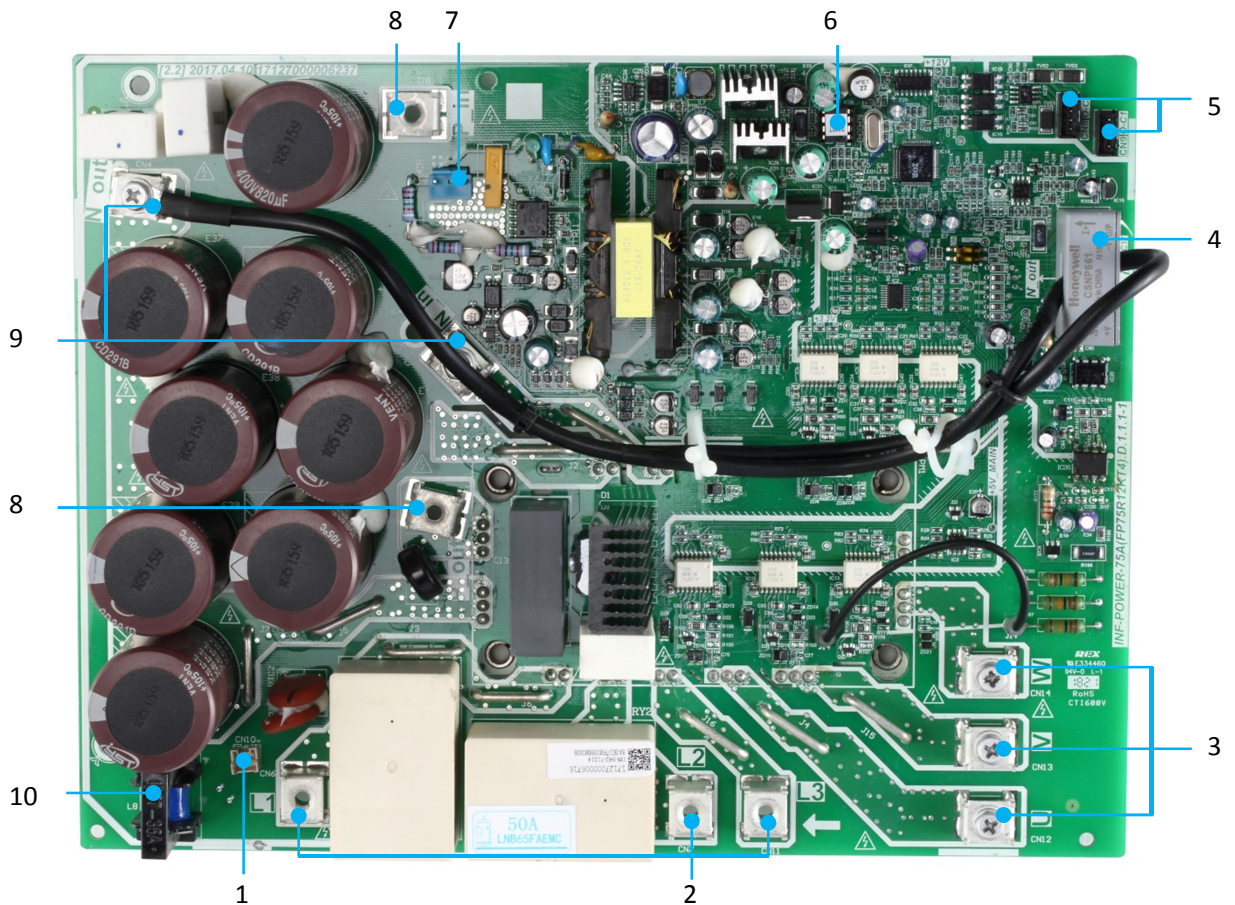

Notes:

1. Label descriptions are given in Table 4-2.5.

Table 4-2.5: Compressor inverter module PCB for 30kW and 60kW units

Label in Figure 4-2.5	Code	Content	Voltage
1	CN10	Port for current detection port(CN15) of main control board	0~5V DC
2	L1	Port for three-phase power supply of filter board	400V AC
	L2		
	L3		
3	U	Port for compressor connection	0~400V AC
	V		
	W		
4	CN17	DC bus current transformer	0~0.34V DC
5	CN8	Communication port between compressor invert modules or communication	0~5V DC
	CN9	port between compressor invert module and main control board	
6	IC25	EEPROM	5V DC
7	CN2	Port for power supply	310V DC
8	CN1	Port for electric reactor	560V DC
	CN5		
9	CN3	Port for DC bus	560V DC
10	L8	Current measuring transformer	0~5V DC

2.3.1 Compressor Inverter Module PCB field setting

Table 4-2.6: Compressor inverter module PCB switch settings for 30kW and 60kW units

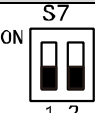
Switch	Description
	000: 30kW unit compressor inverter module address setting
	000: 60kW unit compressor A inverter module address setting
	001: 60kW unit compressor B inverter module address setting

2.4 Fan Module Board

Figure 4-2.3: Fan module PCB for all models

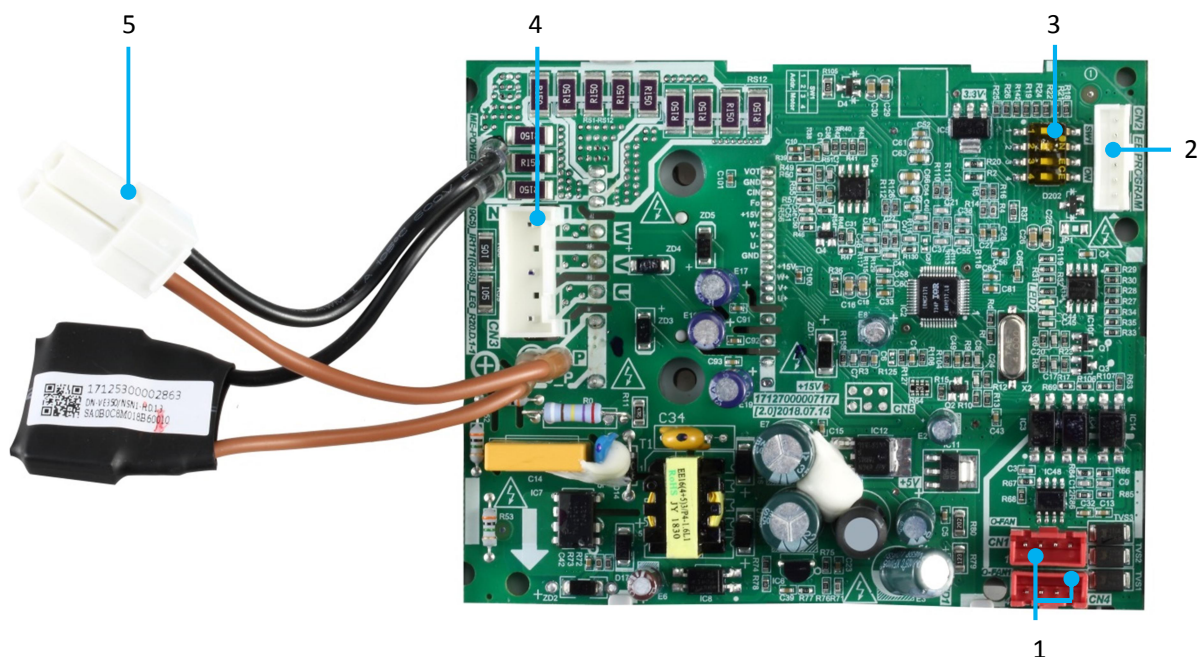

Table 4-2.7: Fan module PCB

Label in Figure 4-2.5	Code	Content	Voltage
1	CN1 CN4	Communication port for inverter module Communication port between fan modules or communication port between fan module and main control board	0~5V DC
2	CN2	EEPROM debug port	0~5V DC
3	SW1	Address dialing code for fan module	0 或 5V DC
4	CN3	Port for fan motor	0~400V AC
5	P N	Port for power supply	310V DC

2.4.1 Fan Module PCB field setting

Table 4-2.8: Fan module PCB switch settings for all models

Switch	Description	
	SW1-1 SW1-2	00: 30kW unit fan module address setting 00: 60kW unit fan module A address setting 01: 60kW unit fan module B address setting
	SW1-3 SW1-4	Reserved

2.5 AC Filter Board

Figure 4-2.4: AC filter board¹ for 30kW unit

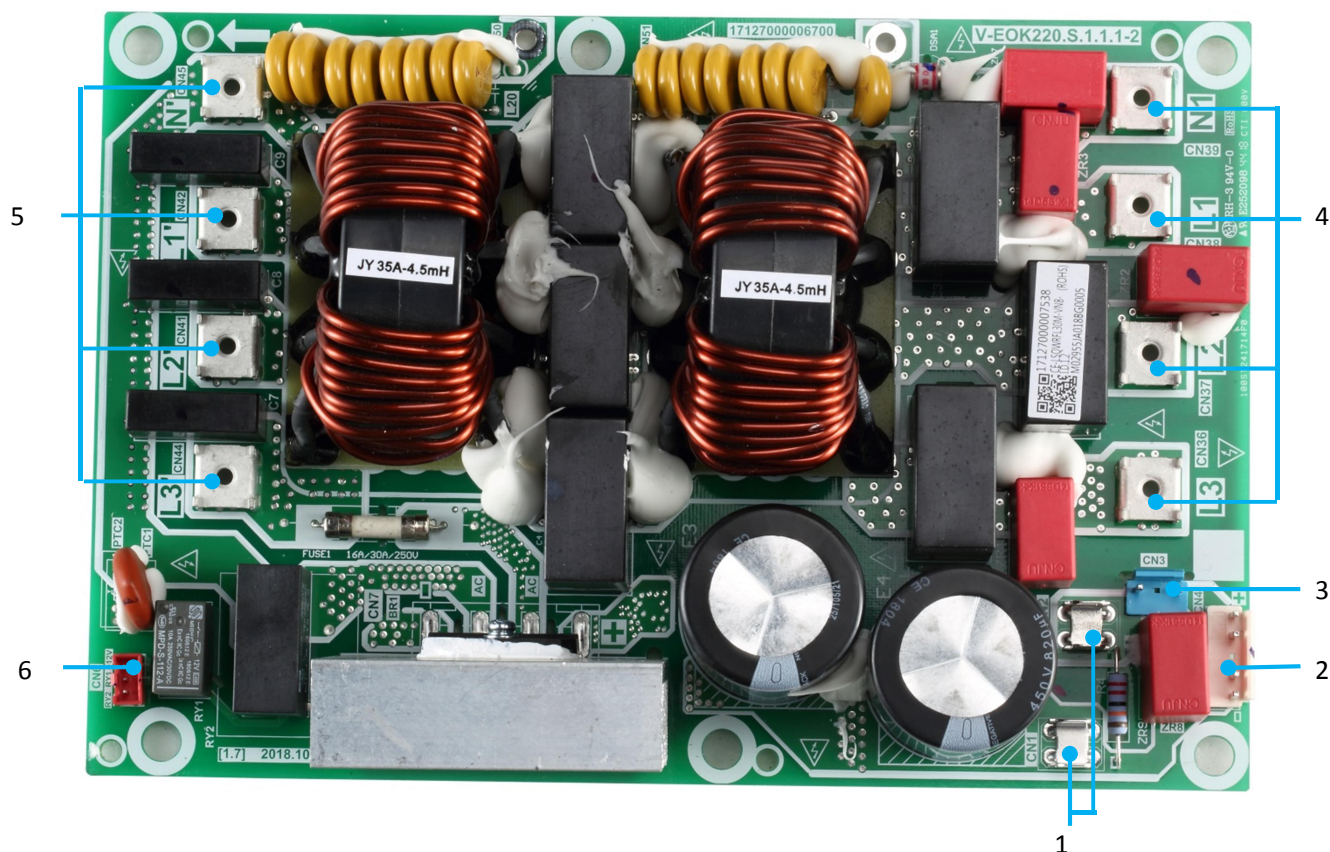

Notes:

1. Label descriptions are given in Table 4-2.9.

Table 4-2.9: AC filter board for 30kW unit

Label in Figure 4-2.6	Code	Content	Voltage
1	CN1 CN2	Port for fan module PCB	310V DC
2	CN4	Port for power supply of compressor inverter module	310V DC
3	CN3	Port for high pressure switch	0 或 310V DC
4	CN36 CN37 CN38 CN39	Three-phase power input	L1&N:230V~ L2&N:230V~ L3&N:230V~
5	CN45 CN42 CN41 CN44	Three-phase power output	L1&N:230V~ L2&N:230V~ L3&N:230V~
6	CN6	Port for relay signal control port of main control board	0 或 12V DC

Figure 4-2.5: AC filter board¹ for 60kW unit

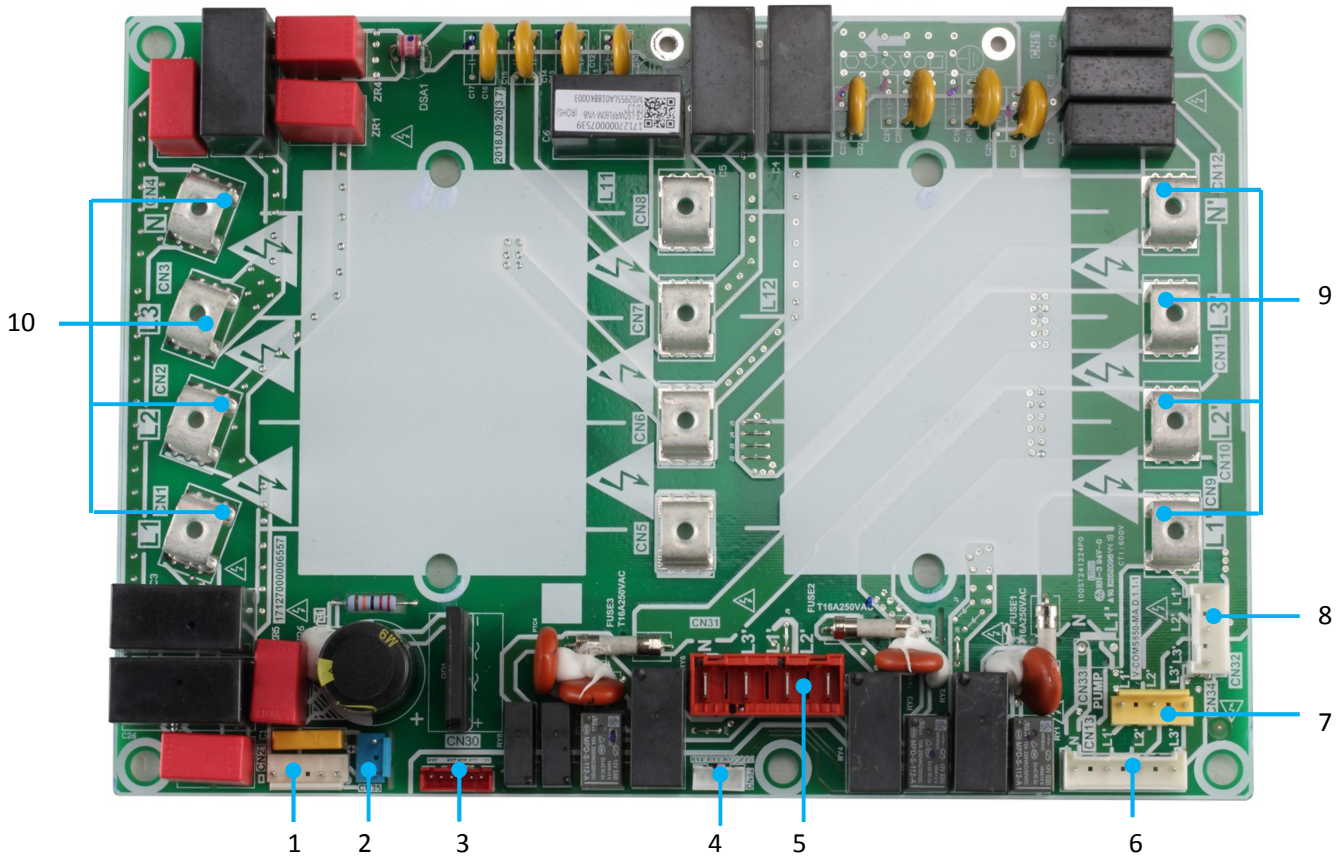

Notes:

1. Label descriptions are given in Table 4-2.10.

Table 4-2.10: AC filter board for 60kW unit

Label in Figure 4-2.6	Code	Content	Voltage
1	CN21	Port for power supply of compressor inverter module	310V DC
2	CN35	Port for high pressure switch	0 or 310V DC
3	CN30	Port for relay signal control port of main control board(CN21)	0 or 12V DC
4	CN52	Port for relay signal control port of main control board(CN52)	0 or 12V DC
5	CN31	Port for fan bridge pile	L1&N:230V~ L2&N:230V~ L3&N:230V~
6	CN13	Port for power supply of main control board	L1&N:230V~ L2&N:230V~ L3&N:230V~
7	CN34	Port for pump	L1&N:400V~ L2&N:400V~ L3&N:400V~
8	CN32	Port for three phase protector	L1&N:400V~ L2&N:400V~ L3&N:400V~
9	CN9 CN10 CN11 CN12	Three-phase power output	L1&N:230V~ L2&N:230V~ L3&N:230V~

Table continued on next page ...

Table 4-2.10: AC filter board for 60kW unit (continued)

10	CN1	Three-phase power input	L1&N:230V~
	CN2		L2&N:230V~
	CN3		L3&N:230V~
	CN4		

2.6 Fan Module Power Board

Figure 4-2.6: Fan module power board¹ for 60kW unit

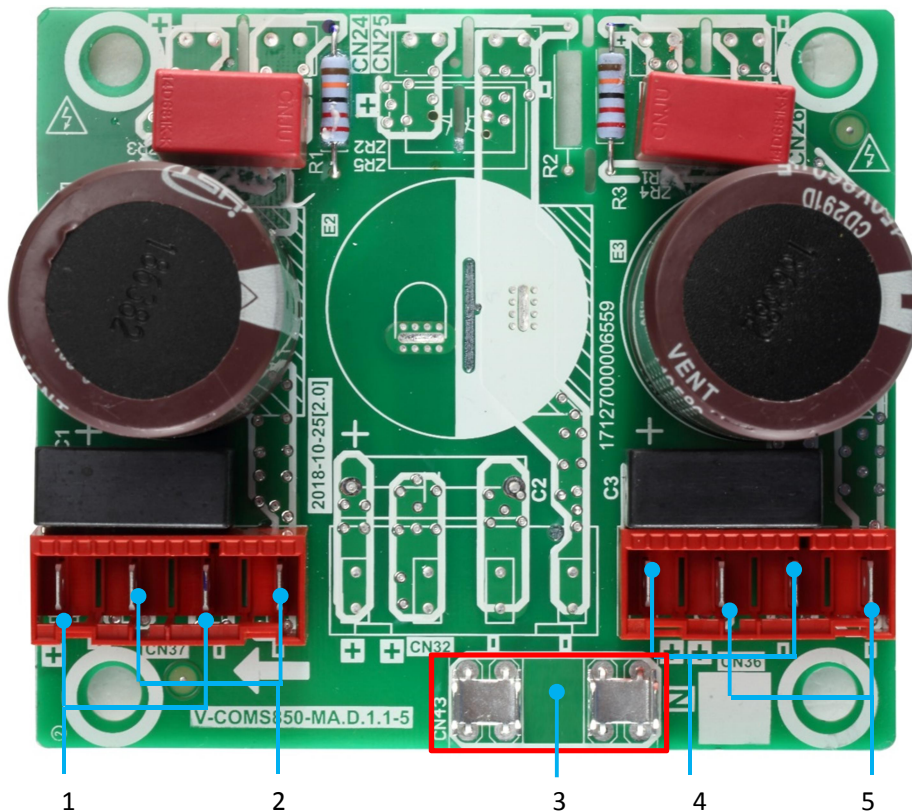

Notes:

1. Label descriptions are given in Table 4-2.11.

Table 4-2.11: Fan power board for 60kW unit

Label in Figure 4-2.8	Code	Content	Voltage
1	CN37	Port output for fan A rectifier bridge	310V DC
2	CN37	Port input for fan A inverter module board	310V DC
3	CN43	N	Neutral
4	CN36	Port output for fan B rectifier bridge	310V DC
5	CN36	Port input for fan B inverter module board	310V DC

3 Error Code Table

Table 4-3.1: Error Code Table (30kW and 60kW units)

Error code	Serial number ¹	Content	Remarks
E0	1	Main control parameter memory EEPROM failure	Displayed on main PCB and user interface
E1	2	Phase sequence failure of main control board check	Displayed on main PCB and user interface
E2	3	Communication failure between master and the HMI	Displayed on main PCB and user interface
	3	Communication failure between master and the slave	Displayed on main PCB and user interface
E3	4	Total water outlet temperature sensor (Tw) failure (displayed on master unit only)	Displayed on main PCB and user interface
E4	5	Unit water outlet temperature sensor (Two) failure	Displayed on main PCB and user interface
E5	6	1E5 condenser tube temperature sensor T3A failure	Displayed on main PCB and user interface
	6	2E5 condenser tube temperature sensor T3B failure	Displayed on main PCB and user interface
E7	8	Ambient temperature sensor (T4) failure	Displayed on main PCB and user interface
E8	9	Power supply phase sequence protector output error	Displayed on main PCB and user interface
E9	10	Water flow detection failure	Displayed on main PCB and user interface
Eb	12	1Eb --> Taf1 cooling evaporator low-temperature anti-freeze protection sensor failure	Displayed on main PCB and user interface
	12	2Eb --> Taf2 cooling evaporator low-temperature anti-freeze protection sensor failure	Displayed on main PCB and user interface
EC	13	Slave unit module reduction	Displayed on user interface
Ed	14	1Ed --> A system discharge temperature sensor failure	Displayed on main PCB and user interface
	14	2Ed --> B system discharge temperature sensor failure	Displayed on main PCB and user interface
EF	16	Unit water return temperature sensor (Twi) failure	Displayed on main PCB and user interface
EH	17	System self-check failure alarm	Displayed on main PCB and user interface
EP	19	Discharge temperature sensor failure alarm	Displayed on main PCB and user interface
EU	20	Tz/7 Coil final outlet temperature sensor error	Displayed on main PCB and user interface
P0	21	System high-pressure protection or discharge temperature protection	Displayed on main PCB and user interface

Table continued on next page ...

Table 4-3.1: Error Code Table (30kW and 60kW units) (continued)

P1	22	System low pressure protection	Displayed on main PCB and user interface
P2	23	Tz/7 Coil final outlet temperature too high	Displayed on main PCB and user interface
P3	24	T4 ambient temperature too high in cooling mode	Displayed on main PCB and user interface
P4	25	System A current protection	Displayed on main PCB and user interface
P5	26	System B current protection	Displayed on main PCB and user interface
P6	27	Inverter module failure	Displayed on main PCB and user interface
P7	28	High temperature protection of system condenser	Displayed on main PCB and user interface
P9	30	Water inlet and outlet temperature difference protection	Displayed on main PCB and user interface
Pb	32	Antifreeze protection in winter	Displayed on main PCB
PC	33	Evaporator pressure too low in cooling	Displayed on main PCB and user interface
PE	35	Cooling evaporator low temperature antifreeze protection	Displayed on main PCB and user interface
PH	37	T4 ambient temperature too high in heating mode	Displayed on main PCB and user interface
PL	38	Inverter module temperature Tfin too high temperature protection	Displayed on main PCB and user interface
xPU	40	DC fan module protection	Displayed on main PCB and user interface
H5	46	Voltage too high or too low	Displayed on main PCB and user interface
xH9	50	Compressor inverter module is not matched	Displayed on main PCB and user interface
xHE	55	Not insert electronic expansion valve	Displayed on main PCB and user interface
xF0	61	IPM module communication failure	Displayed on main PCB
F2	63	Superheat insufficient	Displayed on main PCB and user interface
xF4	65	L0 or L1 protection occurs 3 times in 60 minutes	Displayed on main PCB and user interface
xF6	67	DC bus voltage error (PTC)	Displayed on main PCB and user interface
F7	68	Not insert electronic expansion valve	Displayed on main PCB
xF9	70	Inverter module temperature sensor error	Displayed on main PCB and user interface
Fb	72	Pressure sensor error	Displayed on main PCB and user interface

Table continued on next page ...

Table 4-3.1: Error Code Table (30kW and 60kW units) (continued)

Fd	74	Suction temperatrue sensor error	Displayed on main PCB and user interface
xFF	76	DC fan failure	Displayed on main PCB and user interface
FP	79	DIP inconsistency of multiple water pumps	Displayed on main PCB and user interface
C7	88	If PL occurs 3 times,the system reports the C7 failure	Displayed on main PCB and user interface
L0	101	Compressor inverter module protection	Displayed on only user interface
L1	102	DC bus low voltage protection	Displayed on only user interface
L2	103	DC bus high voltage protection	Displayed on only user interface
L4	105	MCE error	Displayed on only user interface
L5	106	Zero speed protection	Displayed on only user interface
L7	108	Phase sequence lost protection	Displayed on only user interface
L8	109	Compressor frequency change over 15Hz	Displayed on only user interface
L9	110	Compressor frequency difference 15Hz	Displayed on only user interface
dF	146	Defrosting prompt	Displayed on main PCB and user interface

Note:

1. When the error code appears, the error code corresponding to the error code can be obtained through the H1H2 port by using the host computer to query the wired controller register.

4 Troubleshooting

4.1 Warning

Warning



- All electrical work must be carried out by competent and suitably qualified, certified and accredited professionals and in accordance with all applicable legislation (all national, local and other laws, standards, codes, rules, regulations and other legislation that apply in a given situation).
- Power-off the outdoor units before connecting or disconnecting any connections or wiring, otherwise electric shock (which can cause physical injury or death) may occur or damage to components may occur.

4.2 E0/H9 Troubleshooting

4.2.1 Digital display output

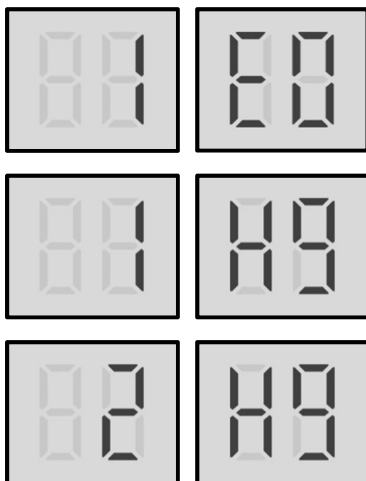

4.2.2 Description

- 1E0 indicates main PCB EEPROM error.
- 1H9 indicates IPM inverter module (compressor A) EEPROM error.
- 2H9 indicates IPM inverter module (compressor B) EEPROM error.
- All units stop running.
- Error code is displayed on main PCB and user interface.

4.2.3 Possible causes

- Main PCB or IPM inverter module EEPROM is not connected properly.
- Main PCB or IPM inverter module damaged.
- EEPROM damaged.

4.2.4 Procedure

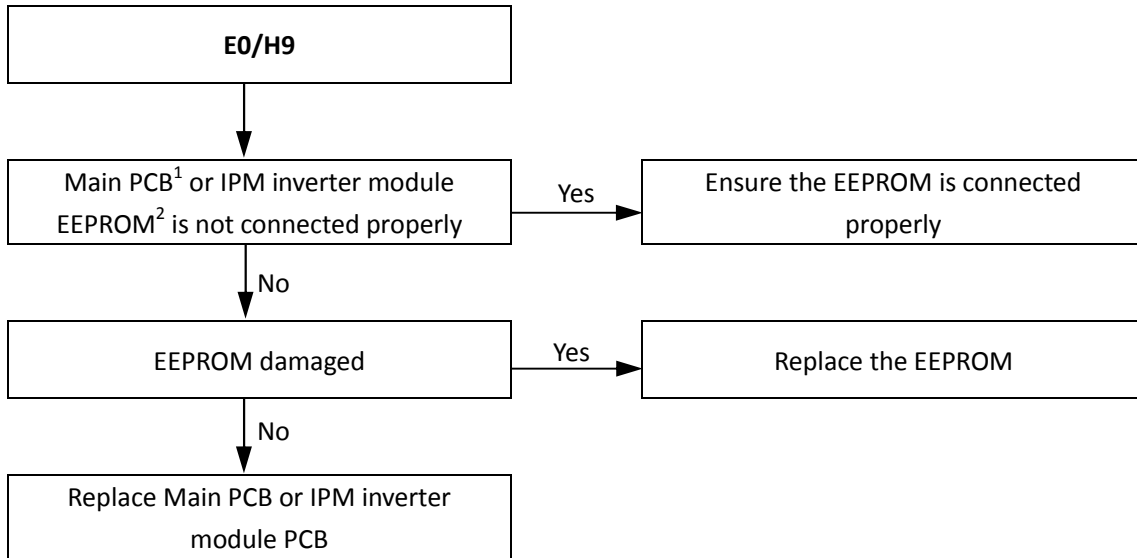

Notes:

For 30kW and 60kW units,

1. Main PCB EEPROM is designated IC10 on the main PCBs (labeled 32 in Figure 4-2.1 in Part 4, 2.2 "Main PCB").
2. Compressor inverter module PCB EEPROM is designated IC25 on compressor inverter module PCB (labeled 6 in Figure 4-2.2 in Part 4, 2.3 "Compressor inverter module PCB").

4.3 E1 Troubleshooting

4.3.1 Digital display output

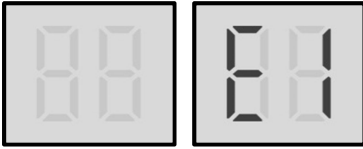

4.3.2 Description

- Phase sequence error.
- Unit stops running.
- Error code is displayed on main PCB and user interface.

4.3.3 Possible causes

- Power supply phases not connected in correct sequence.
- Power supply terminals loose.
- Power supply abnormal.
- Main PCB damaged.

4.3.4 Procedure

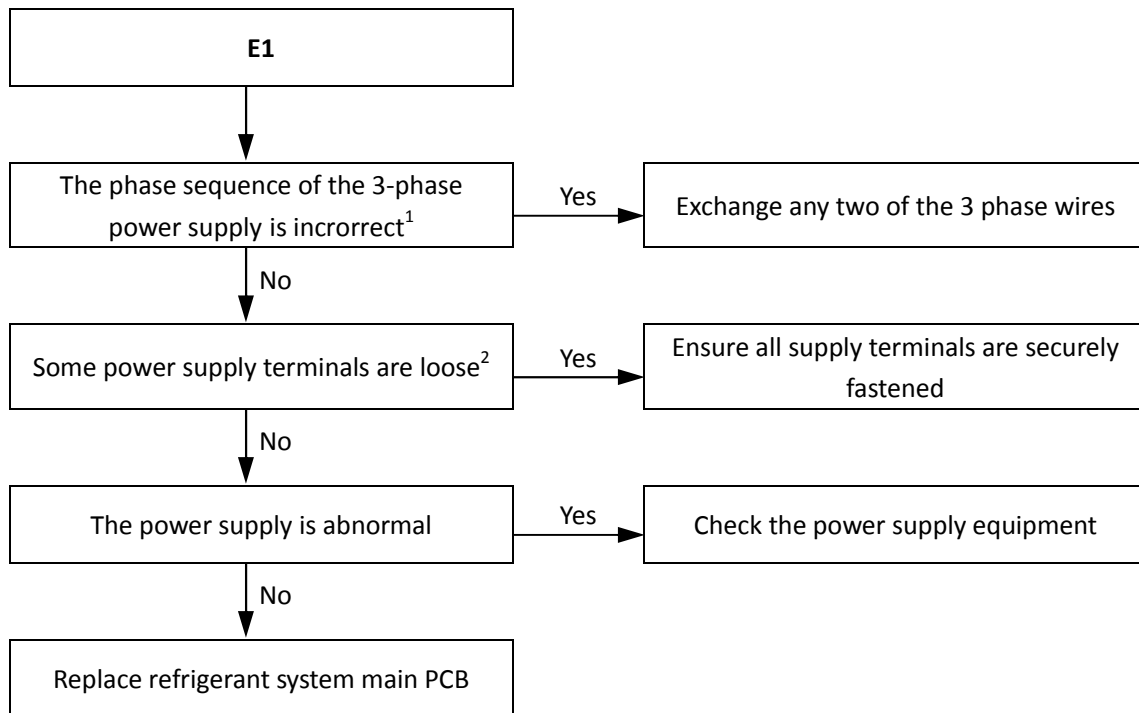

Notes:

1. The A, B, C terminals of 3-phase power supply should match compressor phase sequence requirements. If the phase sequence is inverted, the compressor will operate inversely. If the wiring connection of each outdoor unit is in A, B, C phase sequence, and multiple units are connected, the current difference between C phase and A, B phases will be very large as the power supply load of each outdoor unit will be on C phase. This can easily lead to tripped circuits and terminal wiring burnout. Therefore if multiple units are to be used, the phase sequence should be staggered, so that the current is distributed among the three phases equally.
2. Loose power supply terminals can cause the compressors to operate abnormally and compressor current to be very large.

4.4 E2 Troubleshooting

4.4.1 Digital display output

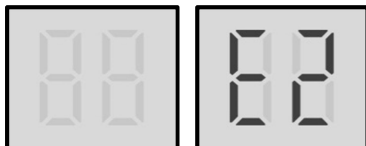

4.4.2 Description

- Communication error between outdoor unit and user interface.
- All units stop running.
- Error code is displayed on main PCB and user interface.

4.4.3 Possible causes

- Communication wires between outdoor unit and user interface are not connected properly.
- Communication wiring P Q E terminals misconnected.
- Loosened wiring within electric control box.
- Interference from high voltage wires or other sources of electromagnetic radiation.
- Communication wire is too long.
- Damaged main PCB, user interface or electric control box communication terminals block.

4.4.4 Procedure

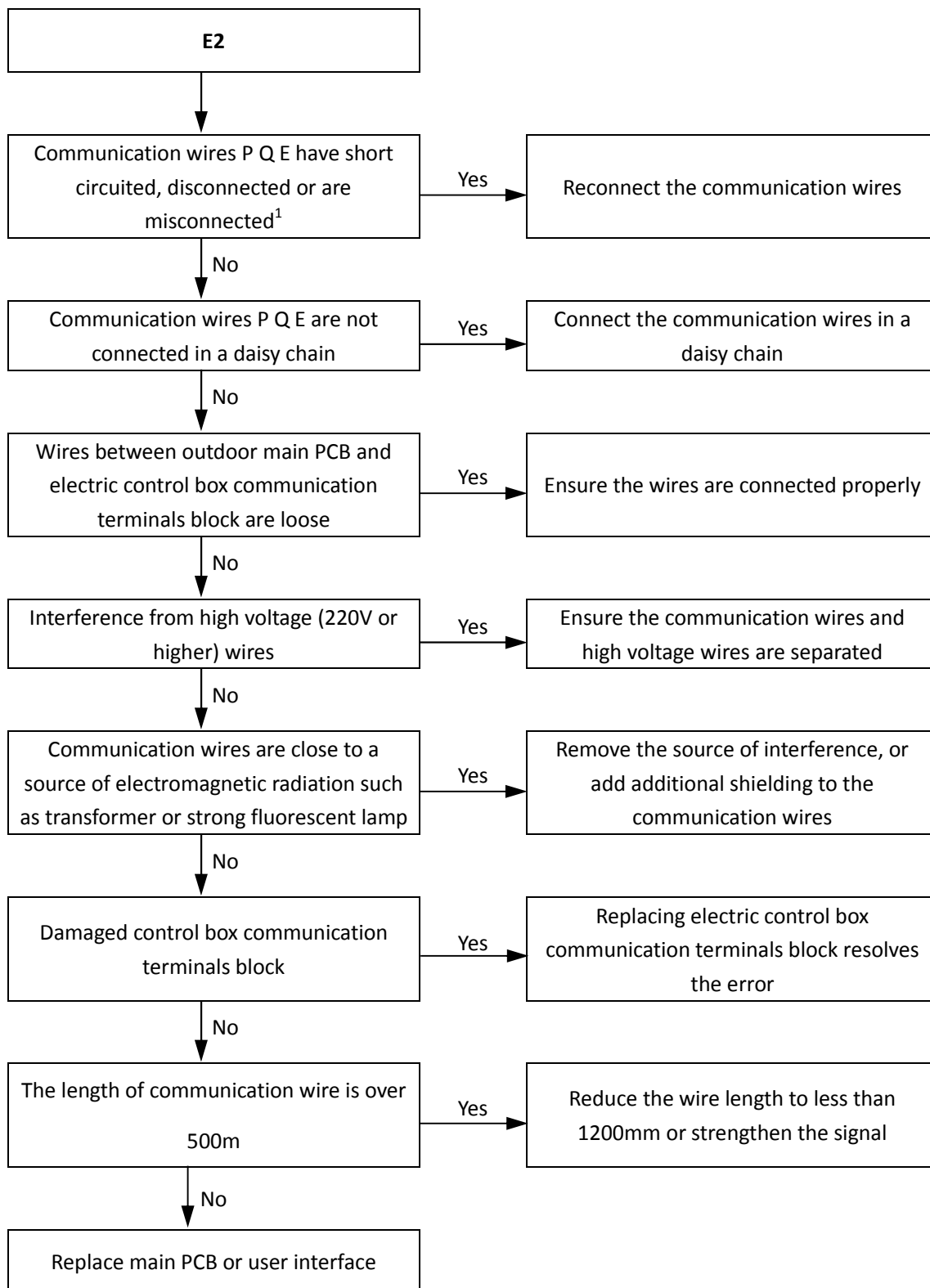

Notes:

1. Measure the resistance among P, Q and E. The normal resistance between P and Q is 120Ω, between P and E is infinite, between Q and E is infinite. Communication wiring has polarity. Ensure that the P wire is connected to P terminals and the Q wire is connected to Q terminals.

4.5 E3, E4, E5, E7, Eb, Ed, EF, EP, EU, F9,Fb, Fd Troubleshooting

4.5.1 Digital display output

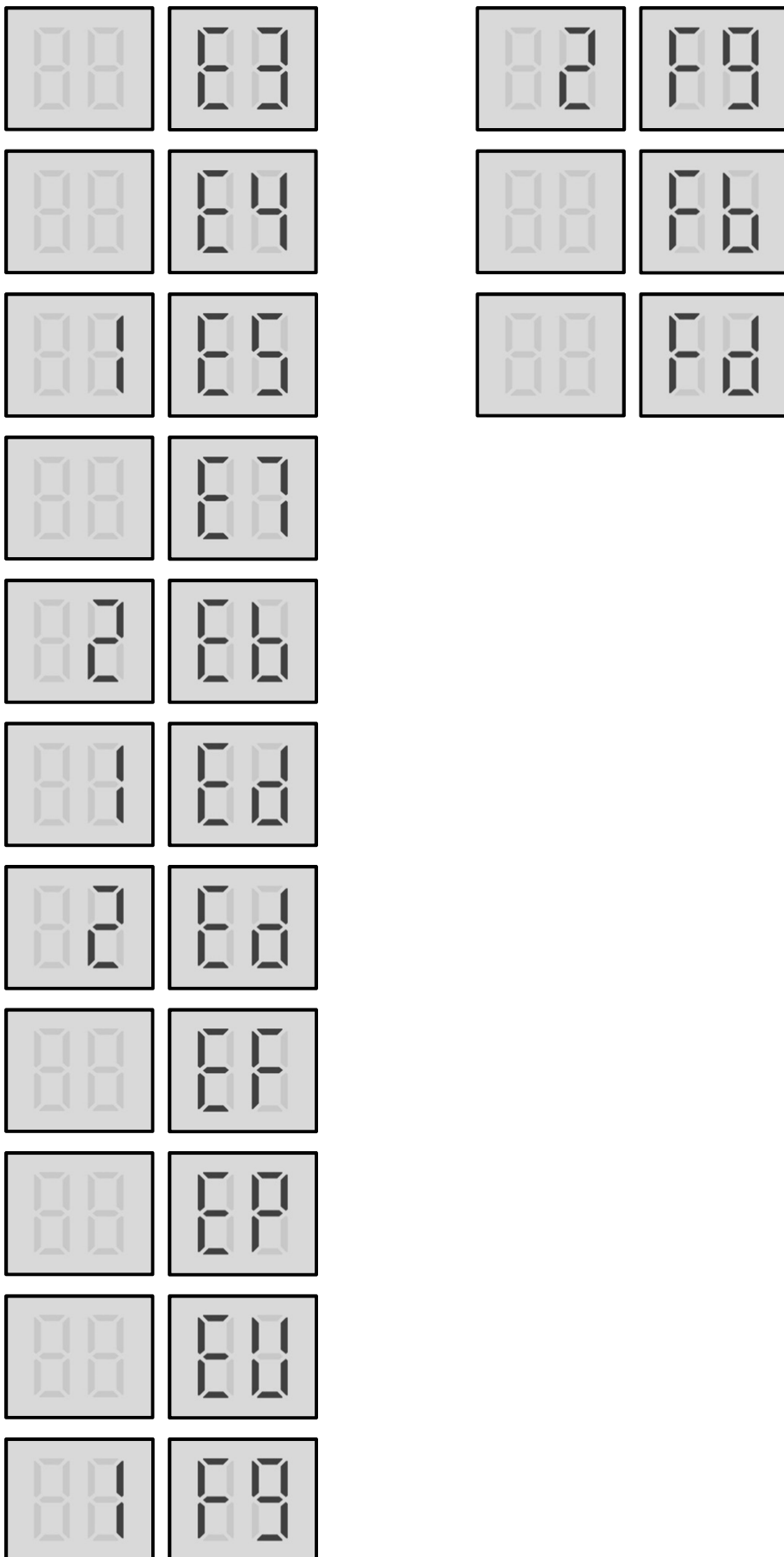

4.5.2 Description

- E3 indicates a combined water outlet temperature sensor error.
- E4 indicates a water outlet temperature sensor error.
- 1E5 indicates an air side heat exchanger refrigerant outlet temperature sensor T3A error.
- E7 indicates an outdoor ambient temperature sensor error.
- 2Eb indicates a water side heat exchanger anti-freezing temperature sensor Taf2 error.
- 1Ed indicates a discharge pipe temperature sensor of system A error.
- 2Ed indicates a discharge pipe temperature sensor of system B error.
- EF indicates a water inlet temperature sensor error.
- EP indicates a discharge pipe temperature sensor failure alarm.
- EU indicates an air side heat exchanger refrigerant total outlet temperature sensor Tz/7 error.
- 1F9 indicates inverter module temperature sensor(Tfin1) error.
- 2F9 indicates inverter module temperature sensor(Tfin2) error.
- Fb indicates a pressure sensor error.
- Fd indicates an air suction temperature sensor error.
- All stop running.
- Error code is displayed on main PCB and user interface.

4.5.3 Possible causes

- Temperature sensor or pressure sensor are not connected properly or malfunctioned.
- Damaged main PCB.

4.5.4 Procedure

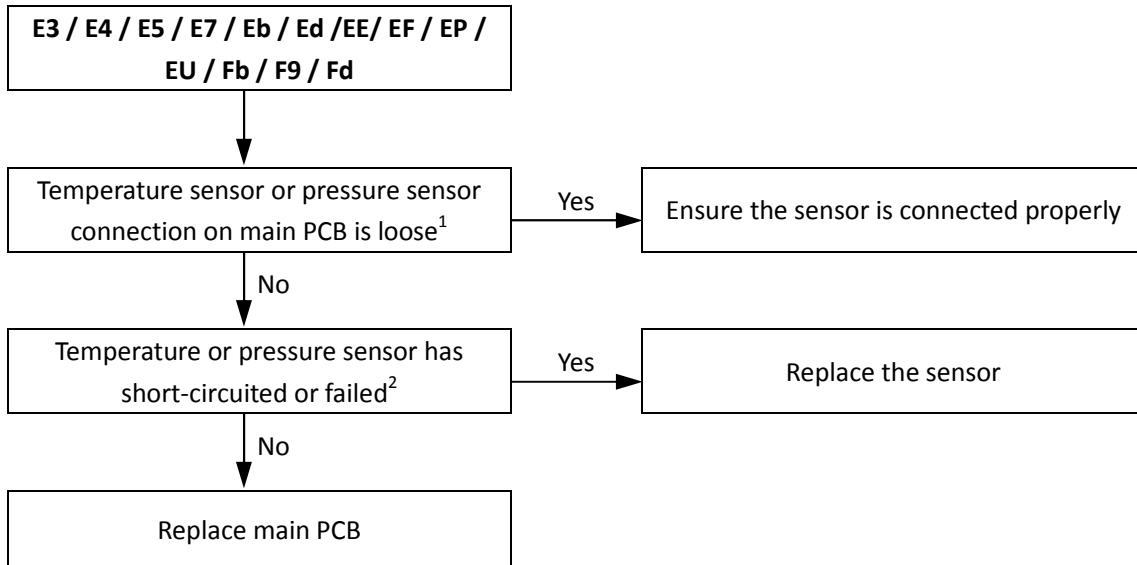

Notes:

1. For 30kW and 60kW units, all the sensors are connected to port CN1, CN16, CN31, CN3, CN10 and CN69 on the main PCB (labeled 10, 9, 8, 7, 6, 4 in Figure 4-2.1 in Part 4, 2.2 "Main PCB").
2. Measure sensor resistance. If the resistance is too low, the sensor has short-circuited. If the resistance is not consistent with the sensor's resistance characteristics table, the sensor has failed. Refer to Table 5-5.1 or 5-5.2 or 5-5.3 in Part 5, 5.1 "Temperature Sensor Resistance Characteristics".

4.6 E8 Troubleshooting

4.6.1 Digital display output

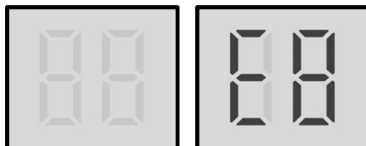

4.6.2 Description

- Power phase protector output error
- When this error occurs in the main unit, all units stop running. When this error occurs in the slave unit, the slave unit stop running.
- Error code is displayed on main PCB and user interface.

4.6.3 Possible causes

- Power supply phases not connected in correct sequence or lose.
- Power supply terminals or power phase protector wire connection loose.
- Power supply abnormal.
- Damaged main PCB.
- Damaged power phase protector.

4.6.4 Procedure

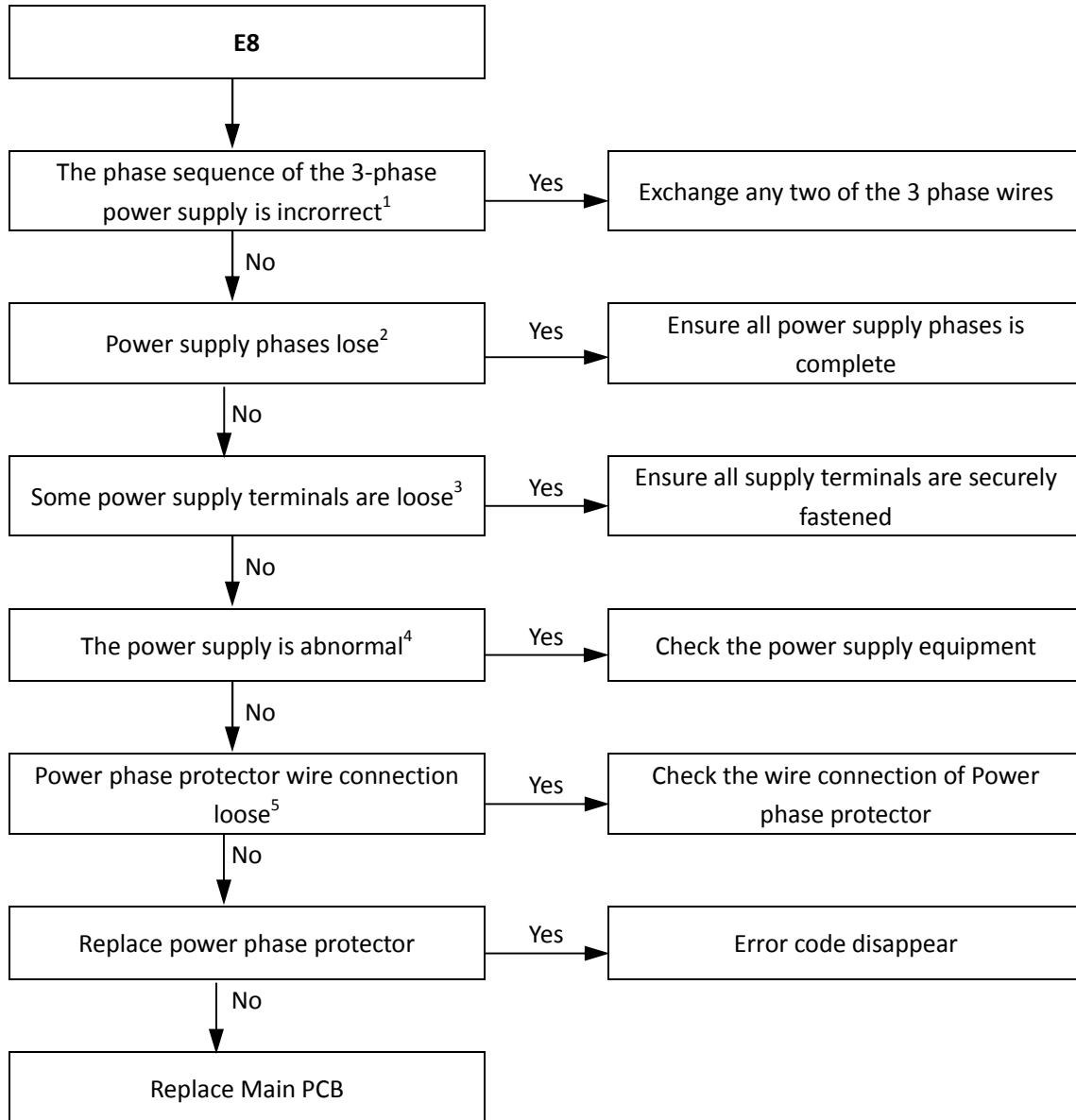

Notes:

1. The red LED on the power phase protector will on.
2. The red LED on the power phase protector will flash with 1HZ.
3. The A, B, C terminals of 3-phase power supply should match compressor phase sequence requirements. If the phase sequence is inverted, the compressor will operate inversely. If the wiring connection of each outdoor unit is in A, B, C phase sequence, and multiple units are connected, the current difference between C phase and A, B phases will be very large as the power supply load of each outdoor unit will be on C phase. This can easily lead to tripped circuits and terminal wiring burnout. Therefore if multiple units are to be used, the phase sequence should be staggered, so that the current is distributed among the three phases equally.
4. The red LED on the power phase protector will flash with 3HZ. Loose power supply terminals can cause the compressors to operate abnormally and compressor current to be very large.

4.7 E9 Troubleshooting

4.7.1 Digital display output

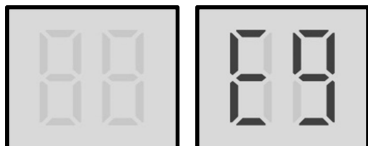

4.7.2 Description

- Water flow failure.
- E9 indicates a water flow switch error. When an E9 error occurs 3 times in 60 minutes, a manual system restart is required before the system can resume operation.
- All units stop running.
- Error code is displayed on main PCB and user interface.

4.7.3 Possible causes

- The wire circuit is short connected or open.
- Water flow rate is too low.
- Water flow switch is damaged.
- Main PCB is damaged.

4.7.4 Procedure

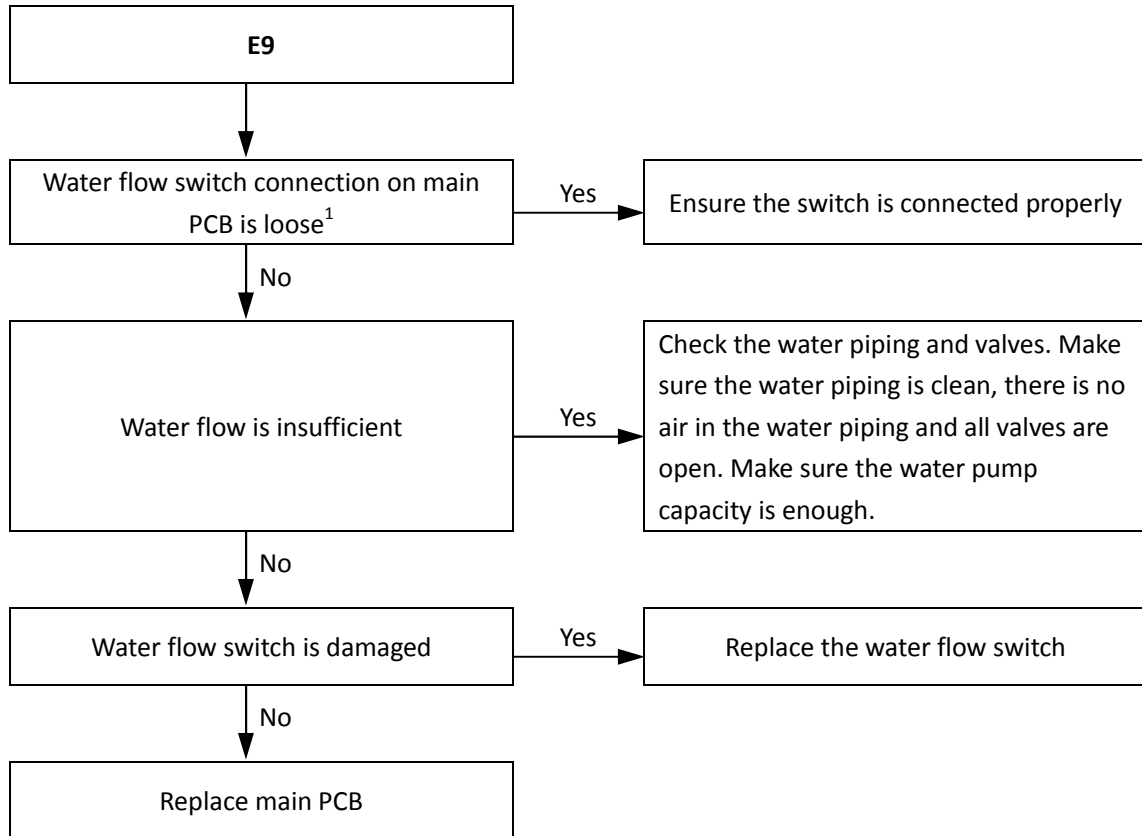

Notes:

1. For 30kW and 60kW units, water flow switch connection is port CN8 on the main PCB (labeled 32 in Figure 4-2.1 in Part 4, 2.2 "Main PCB").

4.8 EC Troubleshooting

4.8.1 Digital display output

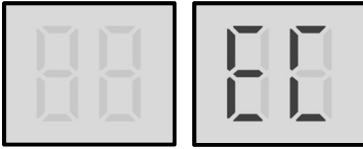

4.8.2 Description

- EC indicates that the number of slave units detected by master unit has decreased.
- All units stop running.
- Error code is only displayed on the user interface.

4.8.3 Possible causes

- Some outdoor units are powered off.
- Power supply abnormal.
- Incorrect outdoor unit address setting.
- Communication wires between outdoor units not connected properly.
- Loosened wiring within electric control box.
- Damaged main PCB or electric control box communication terminals block.

4.8.4 Procedure

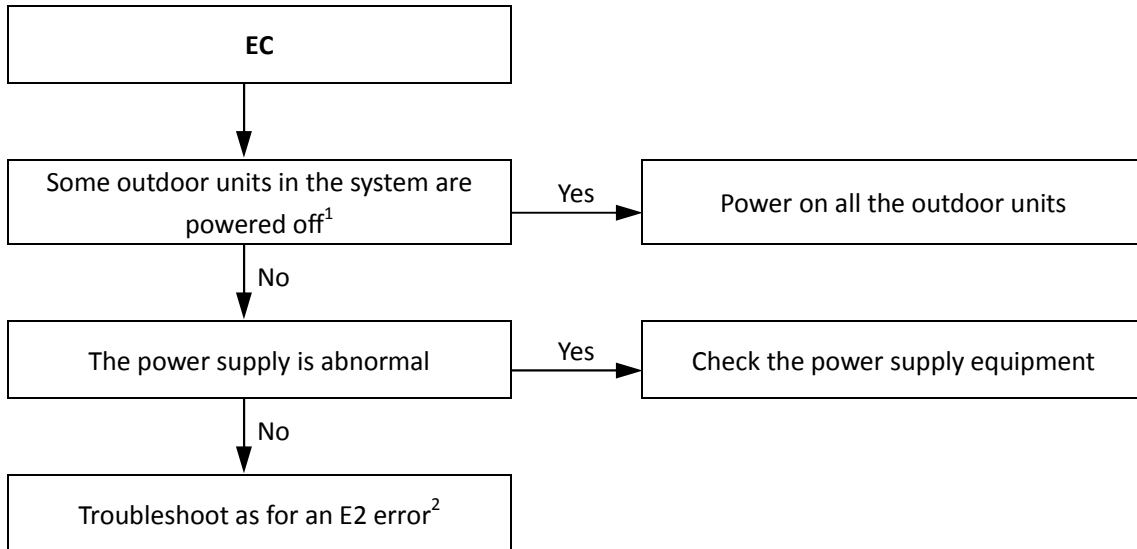

Notes:

1. Check digital display on the main PCB. If digital display is on, the main PCB is powered on, if digital display is off, the main PCB is powered off. For 30kW and 60kW units L, refer to Figure 4-2.1 in Part 4, 2.2 "Main PCB"
2. See Part 4, 4.4 "E2 Troubleshooting".

4.9 EH Troubleshooting

4.9.1 Digital display output

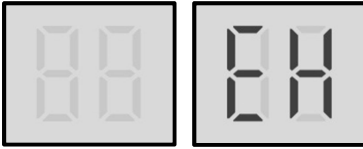

4.9.2 Description

- EH indicates system self-check in the factory, it will not display in the normal operating.

4.10 P0 Troubleshooting

4.10.1 Digital display output

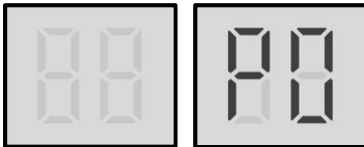

4.10.2 Description

- Discharge pipe high pressure or discharge temperature switch protection. When the discharge pressure rises above 4.2MPa or discharge temperature rises above 115°C, the system displays P0 protection and all units stop running. When the discharge pressure falls below 3.2MPa or discharge temperature fall below 90°C, P0 is removed and normal operation resumes. When P0 error occurs 3 times in 60 minutes, a manual system restart is required before the system can resume operation.
- Error code is displayed on main PCB and user interface.

4.10.3 Possible causes

- High pressure switch or discharge temperature switch not connected properly or has malfunctioned.
- Excess refrigerant.
- System contains air or nitrogen.
- High pressure side blockage.
- Poor condenser heat exchange.
- Main PCB is damaged.

4.10.4 Procedure

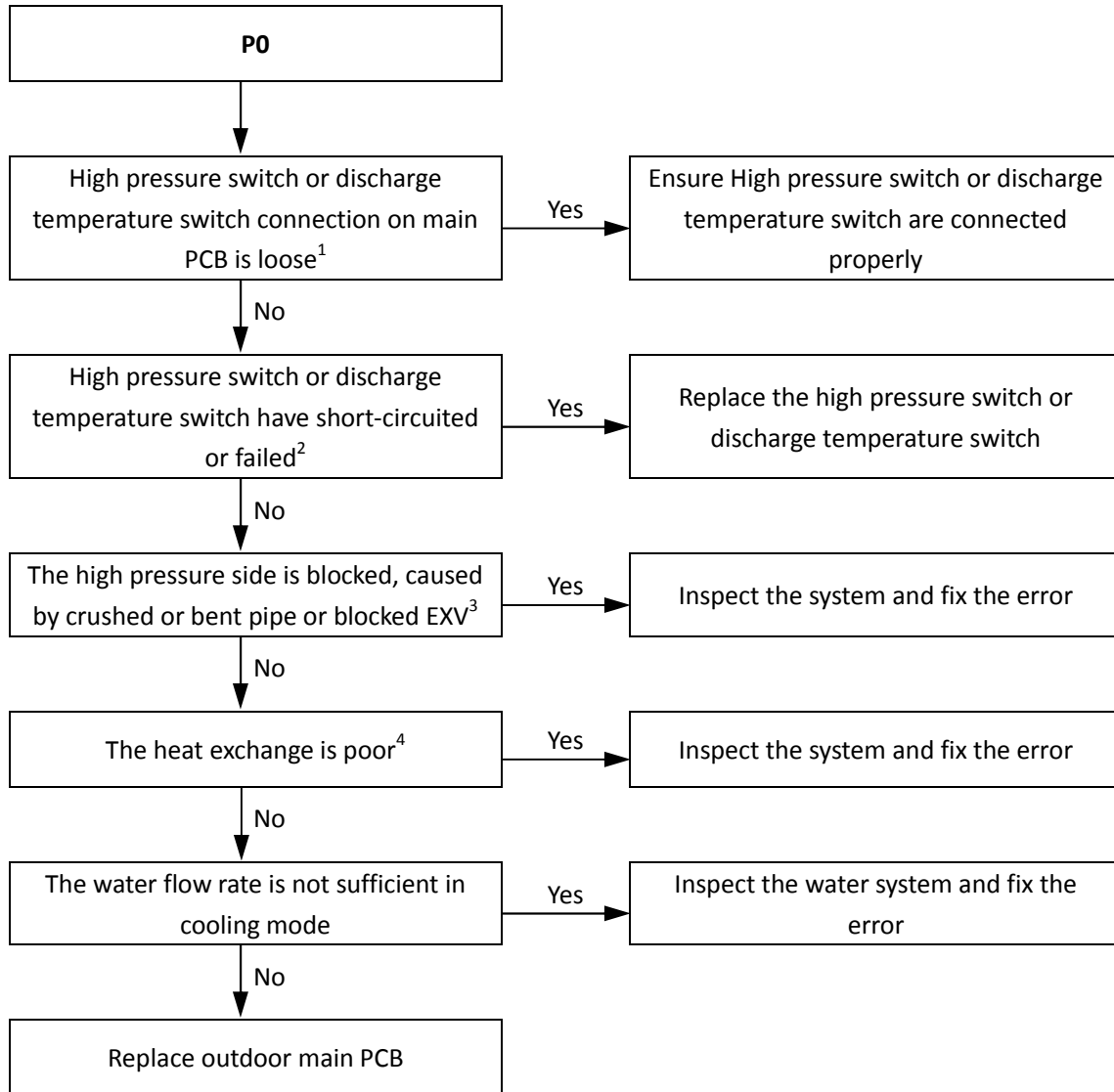

Notes:

1. For 30kW and 60kW units, high pressure switch connection is port CN3 and CN35 on the AC filter board (labeled 3 and 2 in Figure 4-2.1 in Part 4, 2.2 "Main PCB").
2. Measure the resistance among the three terminals of the pressure sensor. If the resistance is of the order of mega Ohms or infinite, the pressure sensor has failed.
3. High pressure side blockage causes discharge temperature to be higher than normal, discharge pressure to be higher than normal and suction pressure to be lower than normal.
4. In heating mode check water side heat exchanger, water piping, circulator pumps and water flow switch for dirt/blockages. In cooling mode check air side heat exchanger, fan(s) and air outlets for dirt/blockages.

4.11 P1 Troubleshooting

4.11.1 Digital display output

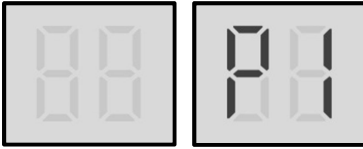

4.11.2 Description

- P1 indicates suction pipe low pressure protection. When the suction pressure falls below 0.14MPa, the system displays P1 protection and all units stop running. When the pressure rises above 0.3MPa, P1 is removed and normal operation resumes. When P1 error occurs 3 times in 60 minutes, a manual system restart is required before the system can resume operation.
- Error code is displayed on main PCB and user interface.

4.11.3 Possible causes

- Low pressure switch not connected properly or has malfunctioned.
- Insufficient refrigerant.
- Low pressure side blockage.
- Poor evaporator heat exchange in heating mode.
- Insufficient water flow in cooling mode.
- Main PCB damaged.

4.11.4 Procedure

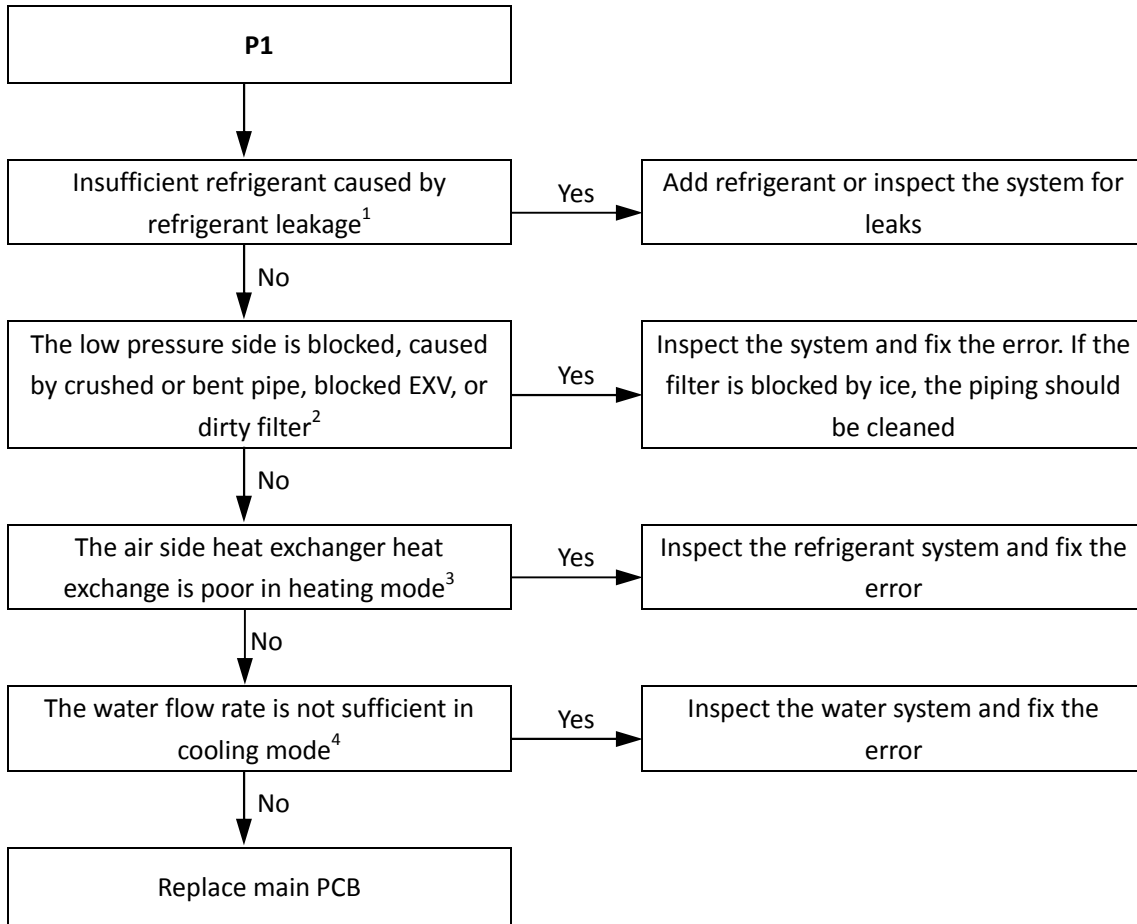

Notes:

1. To check for insufficient refrigerant:
An insufficiency of refrigerant causes compressor discharge temperature to be higher than normal, discharge and suction pressures to be lower than normal and compressor current to be lower than normal, and may cause frosting to occur on the suction pipe. These issues disappear once sufficient refrigerant has been charged into the system.
2. A low pressure side blockage causes compressor discharge temperature to be higher than normal, suction pressure to be lower than normal and compressor current to be lower than normal, and may cause frosting to occur on the suction pipe. For normal system parameters.
3. Check air side heat exchanger, fan(s) and air outlets for dirt/blockages.
4. Check water side heat exchanger, water piping, circulator pumps and water flow switch for dirt/blockages.

4.12 P4, P5 Troubleshooting

4.12.1 Digital display output

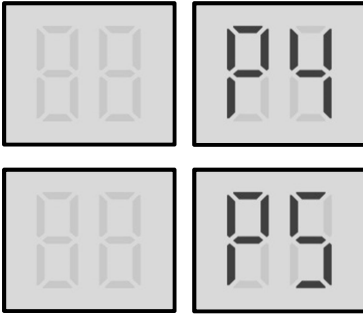

4.12.2 Description

- P4 indicates current protection on Phase A of system A.
- P5 indicates current protection on Phase A of system B.
- When the compressor current rises above the protection value 24A, the system displays P4 or P5 protection and all units stop running. When the current returns to the normal range, P4 or P5 is removed and normal operation resumes. When P4 or P5 error occurs 3 times in 60 minutes, a manual system restart is required before the system can resume operation.
- Error code is displayed on main PCB and user interface.

4.12.3 Possible causes

- Power supply abnormal.
- Poor condenser heat exchange.
- High pressure side blockage.
- Excess refrigerant.
- System contains air or nitrogen.
- Inverter module damaged.
- Compressor damaged.
- Main PCB damaged.

4.12.4 Procedure

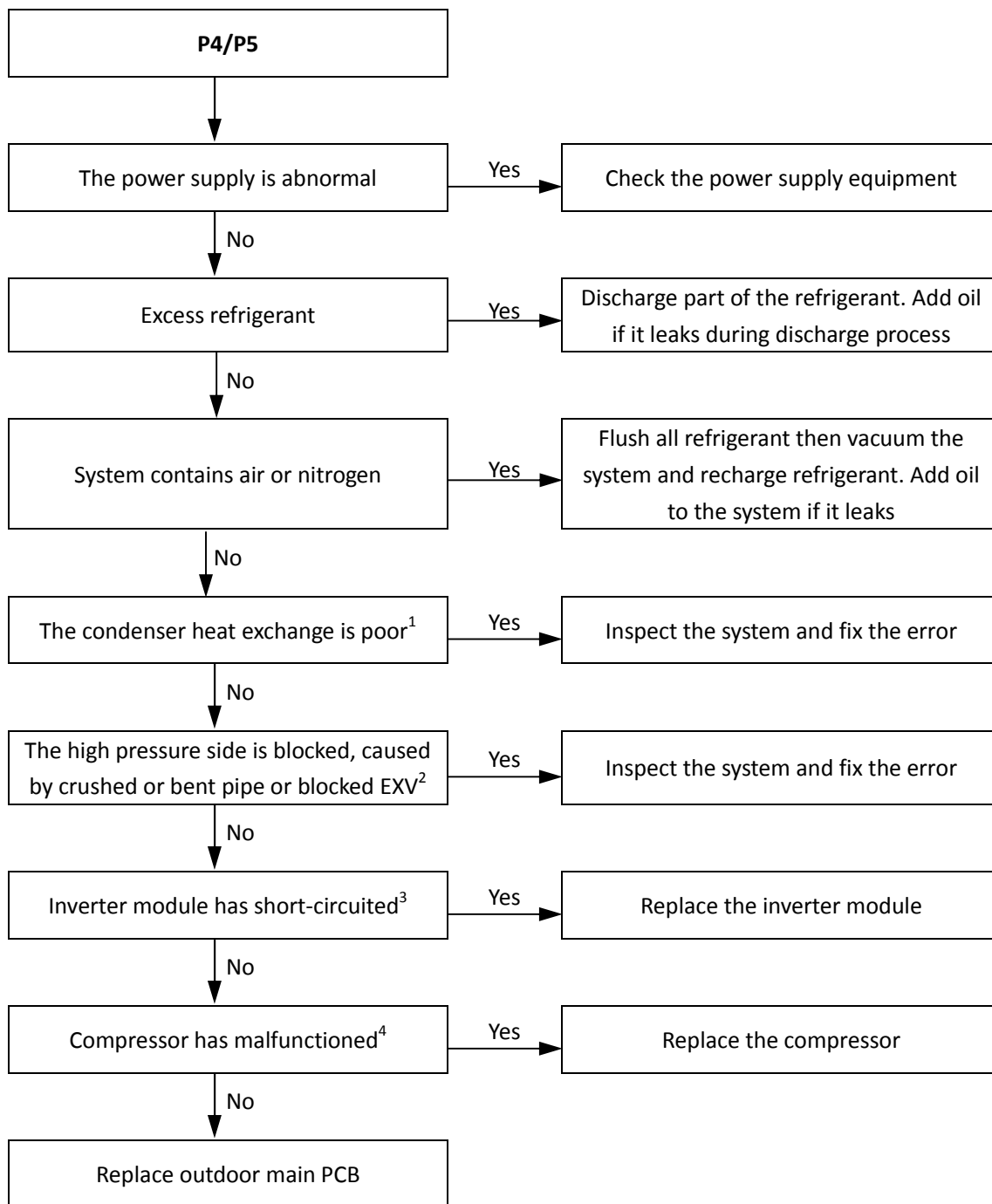

Notes:

1. In heating mode check water side heat exchanger, water piping, circulator pumps and water flow switch for dirt/blockages. In cooling mode check air side heat exchanger, fan(s) and air outlets for dirt/blockages.
2. High pressure side blockage causes discharge temperature to be higher than normal, discharge pressure to be higher than normal and suction pressure to be lower than normal.
3. Set a multi-meter to buzzer mode and test any two terminals of P N and U V W of the inverter module. If the buzzer sounds, the inverter module has short-circuited.
4. The normal resistances of the inverter compressor are 0.7-1.5Ω among U V W and infinite between each of U V W and ground. If any of the resistances differ from these specifications, the compressor has malfunctioned.

4.13 P6 Troubleshooting

4.13.1 Digital display output

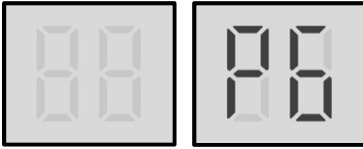

4.13.2 Description

- P6 indicates compressor inverter module protection.
- When P6 error occurs, a manual system restart is required before the system can resume operation. The cause of P6 error should be addressed promptly in order to avoid system damage.
- All units stop running.
- Error code is displayed on the main PCB and user interface.

4.13.3 Possible causes

- Inverter module protection.
- DC bus low or high voltage protection.
- MCE error.
- Zero speed protection.
- Phase sequence error.
- Excessive compressor frequency variation.
- Actual compressor frequency differs from target frequency.

4.13.4 Specific error codes for P6 inverter module protection

If a P6 error code is displayed, press button SW3 until one of the following specific error codes is displayed on the digital display: xL0, xL1, xL2, xL4, xL5, xL7, xL8, xL9. Refer to Figure 4-4.1 and Table 4-4.1.

Figure 4-4.1: Button SW3 on main PCB

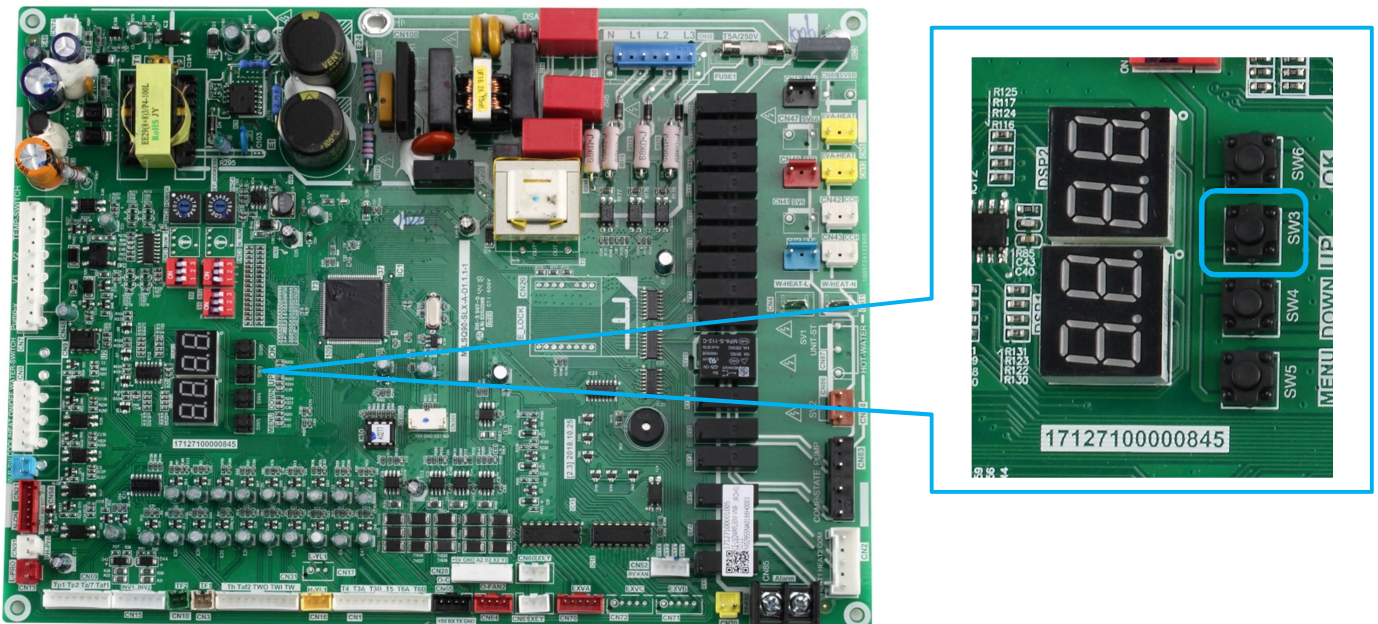

Table 4-4.1: Specific error codes for error xH4

Specific error code ¹	Content
xL0	Inverter module protection
xL1	DC bus low voltage protection
xL2	DC bus high voltage protection
xL4	MCE error
xL5	Zero speed protection
xL7	Phase sequence error
xL8	Compressor frequency variation greater than 15Hz within one second protection
xL9	Actual compressor frequency differs from target frequency by more than 15Hz protection

Notes:

- 'x' is a placeholder for the compressor system (compressor and related electrical components), with 1 representing compressor system A and 2 representing compressor system B.

The specific error codes xL0, xL1, xL2, xL4, xL5 and xL7 can also be obtained from the inverter module LED indicators. If an inverter module error has occurred, LED1 flashes. Refer to Figure 4-4.2 and Table 4-4.2.

Figure 4-4.2: LED indicators LED1 on main PCB

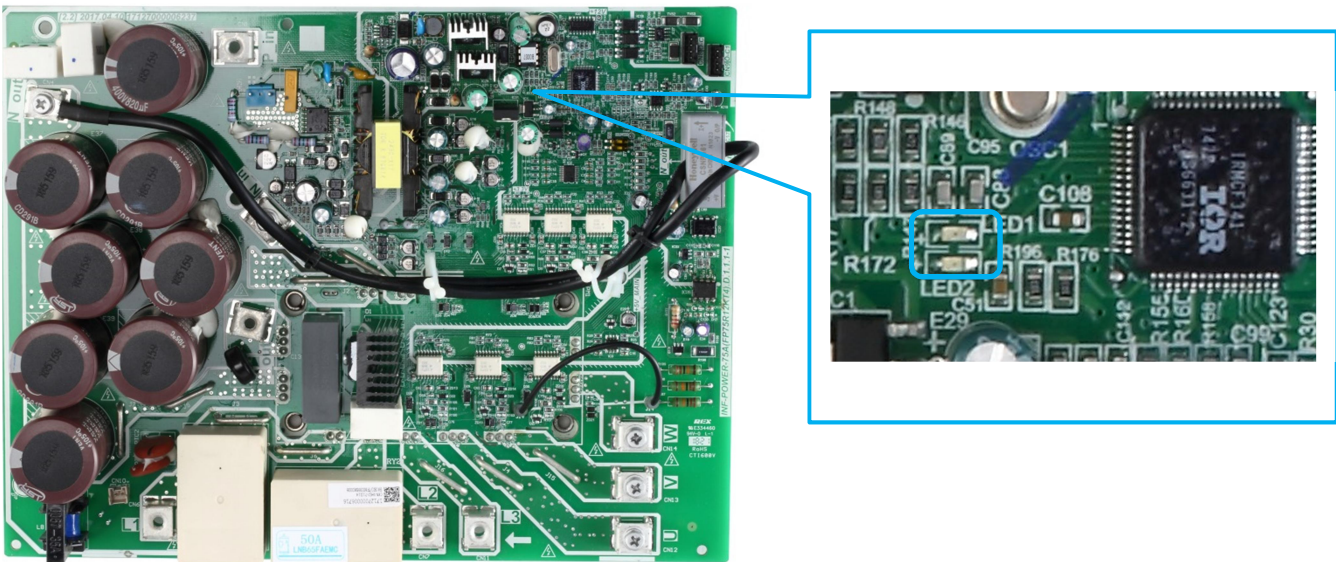

Table 4-4.2: Errors indicated on LED1

LED4/6 flashing pattern	Corresponding error
Flashes 8 times and stops for 1 second, then repeats	xL0 - Inverter module protection
Flashes 9 times and stops for 1 second, then repeats	xL1 - DC bus low voltage protection
Flashes 10 times and stops for 1 second, then repeats	xL2 - DC bus high voltage protection
Flashes 12 times and stops for 1 second, then repeats	xL4 - MCE error
Flashes 13 times and stops for 1 second, then repeats	xL5 - Zero speed protection
Flashes 15 times and stops for 1 second, then repeats	xL7 - Phase sequence error

4.13.5 First troubleshooting step

To troubleshoot XP6 errors, first ensure that the DC bus wire is connected correctly. The DC bus wire should run from the N terminal on the inverter module, through the current sensor (in the direction indicated by the arrow on the current sensor), and end at the N terminal on the DC filter board.

Figure 4-4.3: DC detection wire connection method

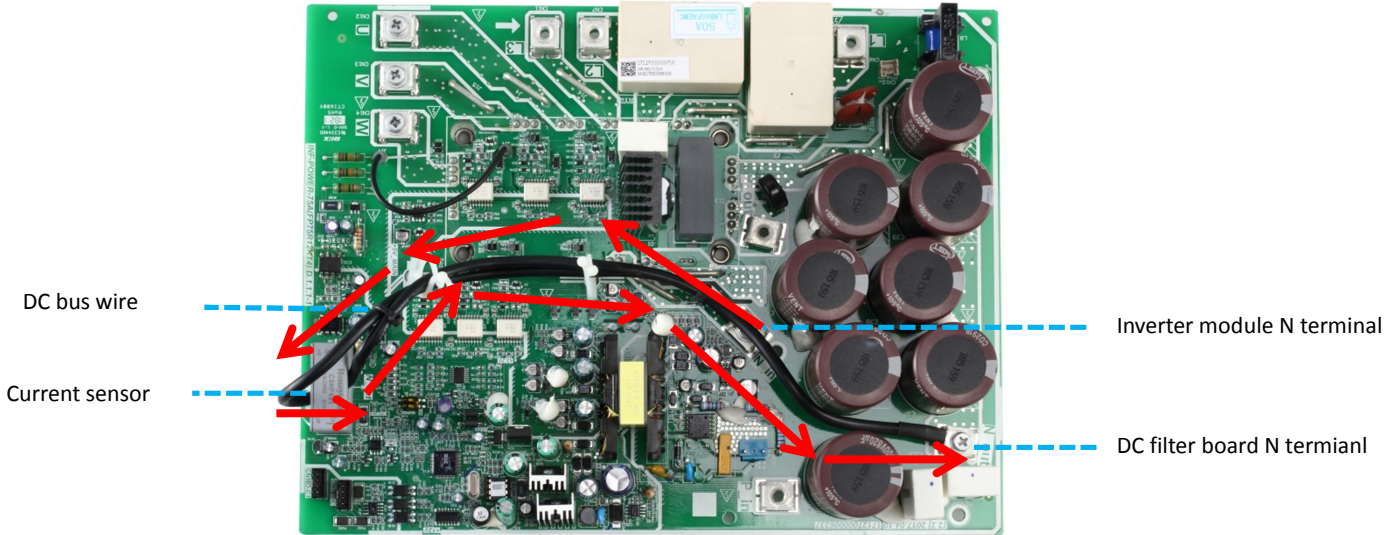

4.13.6 xL0 troubleshooting

Step 1: Check compressor

- Check that compressor wiring is all connected properly.
- The normal resistances of the inverter compressor are 0.7-1.5Ω among U V W and infinite between each of U V W and ground. If any of the resistances differ from these specifications, the compressor has malfunctioned.

Figure 4-4.4: Measuring resistances among compressor terminals

Figure 4-4.5: Measuring resistances between compressor terminals and ground

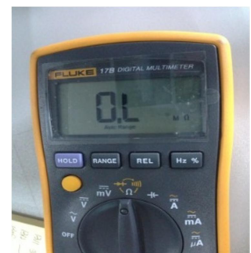
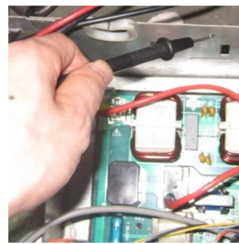

- If the resistances are normal, go to Step 2.

Step 2: Check inverter module

- The DC voltage between terminals P1 and N1 should be 1.41 times the local power supply voltage. The DC voltage between terminals P and N should be 537-586V (power supply voltage specification: 380~415V 3N~). If either voltage is not in the normal range, troubleshoot as for xL1 or xL2 errors. Refer to Part 4, 4.13.7 “xL1/xL4 troubleshooting” or Part 4, 4.13.8 “xL2 troubleshooting”.
- Disconnect the terminals U, N, W from the inverter compressor. Measure the resistance among terminals P, N, U, V, W. All the resistances should be infinite. If any of them are not infinite, the inverter module is damaged and should be replaced.

Figure 4-4.6: Inverter module terminals

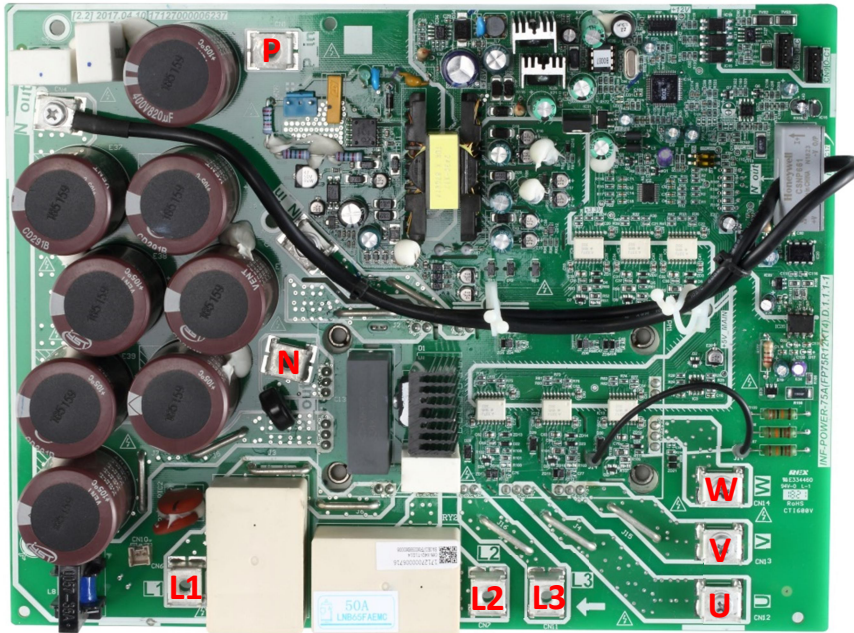

4.13.7 xL1/xL4 troubleshooting

Step 1: Check inverter module

- Check the DC voltage between terminals P and N. The normal value is 537-586V (power supply voltage specification: 380~415V 3N~). If the voltage is lower than 300V, go to Step 2.

Figure 4-4.7: Inverter module terminals

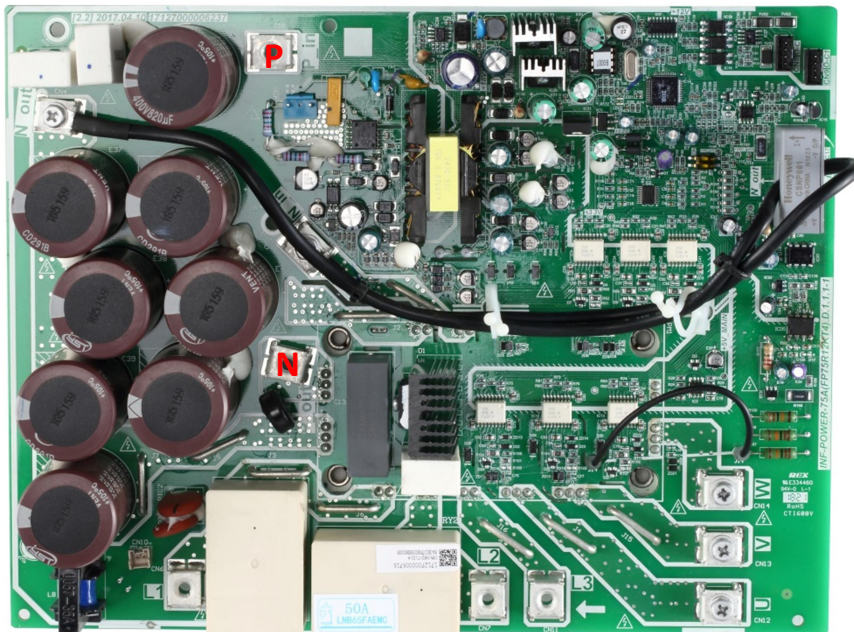

Step 2: Check rectifier wiring circuit

- If the wires are loose, fasten the wires. If the wires are OK, replace the main PCB.

Figure 4-4.8: Rectifier and AC filter board in electric control box

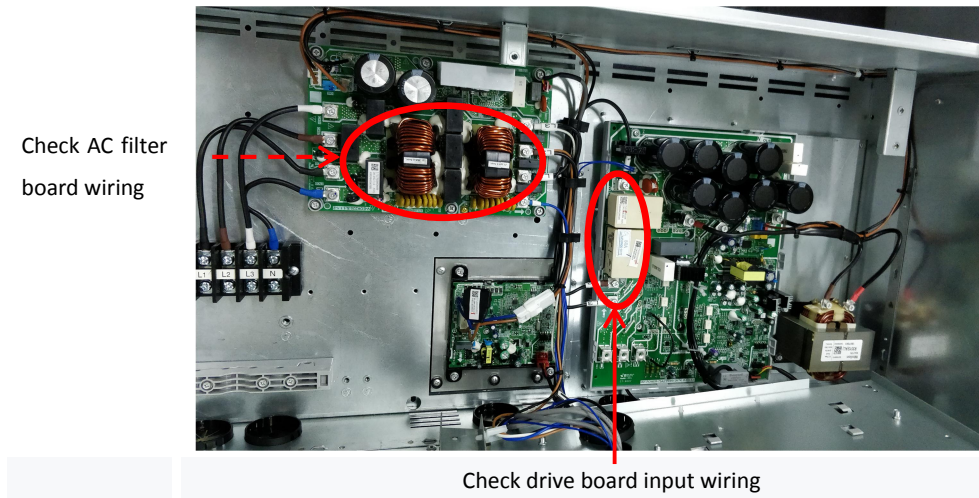

4.13.8 xL2 troubleshooting

Step 1: Check inverter module

- Check the DC voltage between terminals P and N. The normal value is 537-586V (power supply voltage specification: 380~415V 3N~), if the voltage is higher than 800V, go to Step 2.

Figure 4-4.9: Inverter module terminals

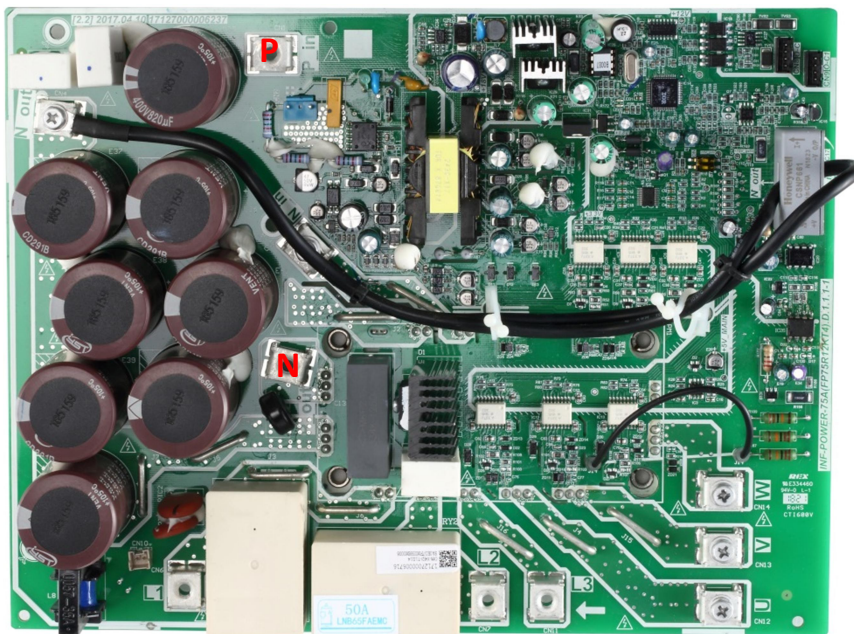

Step 2: Check inverter module

- Check the voltage between terminals P and N on the capacitor board. The normal value is 537-586V (power supply voltage specification: 380~415V 3N~). If the voltage is not in the normal range, there is a problem with the electrolytic capacitor power supply. Check the power supply for high or unstable voltage. If the power supply voltage value is normal, then the main PCB has malfunctioned and needs to be replaced.

4.13.9 xL8/xL9 troubleshooting

Step 1: Check compressor

- The normal resistances of the inverter compressor are 0.7-1.5Ω among U V W and infinite between each of U V W and ground. If any of the resistances differ from these specifications, the compressor has malfunctioned.
- Refer to Figures 4-4.4 and 4-4.5 in Part 4, 4.13.6 “xL0 troubleshooting”. If the resistance values are normal, go to Step 2.

Step 2: Check compressor and main PCB

- If there is another unit nearby (either in the same system or another system) that is operating normally, its electric control box can be used to determine whether the xL8/xL9 error is being caused by a compressor fault or a main PCB fault:
 - If using another unit in the same system as the unit with the error to perform the test, set it as the master unit (address 0); if using a unit in another system, use the master unit.
 - Disconnect the power wires of the compressor referenced in the xL8/xL9 error code.
 - In the unit that is operating normally, disconnect the power wires that connect a compressor to the electric control box and use them to connect the compressor with the xL8/xL9 error to the electric control box of the unit that is operating normally. Ensure that the U, V, W terminals are connected in the right order, and then start the system that is operating normally.
 - If the compressor with the xL8/xL9 error runs normally, replace the main PCB of the unit with the xL8/xL9 error and ensure the wiring is correct; if the compressor with the xL8/xL9 error still does not run normally, it needs to be replaced. Refer to Part 4, 4.13.10 “Compressor replacement procedure”.

Figure 4-4.10: Connecting compressor to an error-free unit



- If there is no error-free unit nearby:
 - Replace the main PCB of the unit with the xL8/xL9 error and ensure the wiring is correct. If the compressor with the xL8/xL9 error runs normally, a fault with the main PCB was causing the xL8/xL9 error; if the compressor with the xL8/xL9 error still does not run normally, it needs to be replaced. Refer to Part 4, 4.12.10 “Compressor replacement procedure”.

4.13.10 Compressor replacement procedure

Step 1: Remove faulty compressor and remove oil

- Remove the faulty compressor from the outdoor unit.
- Before removing the oil, shake the compressor so as to not allow impurities to remain settled at the bottom.
- Drain the oil out of the compressor and retain it for inspection. Normally the oil can be drained out from the compressor discharge pipe. Refer to Figure 4-4.12.

Figure 4-4.10: Draining oil from a compressor



Step 2: Inspect oil from faulty compressor

- If the oil is clear and transparent, go to Step 6. Slightly yellow oil is not an indication of any problems.
- If the oil is dark, black or contains impurities, the system has problems and the oil needs to be changed and go to Step 3. (If the compressor oil has been spoiled, the compressor will not be being lubricated effectively. The moving parts will wear. Abrasion will lead to a larger load and higher current. More electric energy will get dissipated as heat and the temperature of the motor will become increasingly high. Finally, compressor damage or burnout will result)

Figure 4-4.11: Inspecting compressor oil



Step 3: Replace oil separator, accumulator and high pressure tank

- If the oil from a compressor is spoiled, replace oil separator, accumulator and high pressure tank.

Step 4: Check filter

- If the oil from a compressor is spoiled, check filters in the unit. If it is blocked, clean with nitrogen or replace.

Step 5: Clear the oil in the system

- If the oil from a compressor is spoiled, clear the oil in the system by nitrogen to ensure there is no spoiled oil in it.

Step 6: Replace compressor

- If the oil drained from the faulty compressor is clean and transparent in Step 2, replace the faulty compressor.

- If the oil drained from the faulty compressor is spoiled in Step 3, replace the faulty compressor and other compressor in the system. (30kW unit has one compressor; 60kW unit has two compressors)

Step 7: Vacuum drying and refrigerant charging

- Once all the compressors and other components have been fully connected, vacuum dry the system and recharge refrigerant.

4.14 P7 Troubleshooting

4.14.1 Digital display output

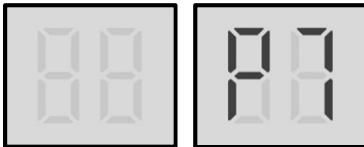

4.14.2 Description

- High temperature protection of air side heat exchanger refrigerant outlet temperature sensor or air side heat exchanger refrigerant total outlet temperature sensor in cooling mode. When the air side heat exchanger refrigerant outlet temperature is higher than 60°C or air side heat exchanger refrigerant total outlet temperature is higher than 61°C for more than 3 seconds, the system displays P7 protection and all units stop running. When the air side heat exchanger refrigerant outlet temperature drops below 50°C or air side heat exchanger refrigerant total outlet temperature drops below 58°C, P7 is removed and normal operation resumes.
- All units stop running.
- Error code is displayed on main PCB and user interface.

4.14.3 Possible causes

- Air side heat exchanger refrigerant outlet temperature sensor or air side heat exchanger refrigerant total outlet temperature sensor not connected properly or has malfunctioned.
- Fan motor wiring connection is wrong.
- Poor condenser heat exchange.
- Fan motor damaged.
- Main PCB damaged.

4.14.4 Procedure

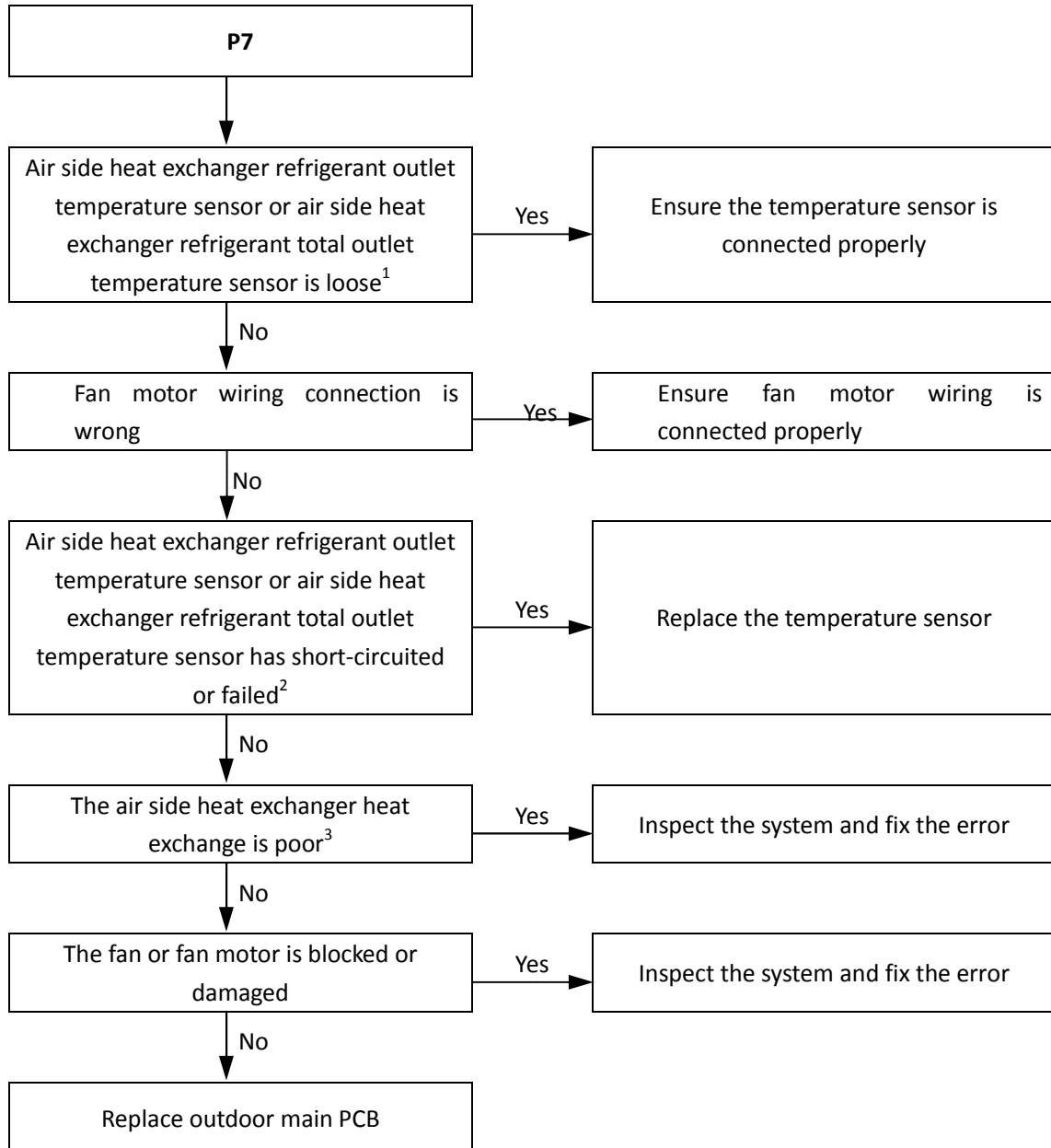

Notes:

1. For 30kW and 60kW units, air side heat exchanger refrigerant outlet temperature sensor and air side heat exchanger refrigerant total outlet temperature sensor connection port is CN1 and CN69 on the main PCB (labeled 10 and 4 in Figure 4-2.1 in Part 4, 2.2 "Main PCB").
2. Measure sensor resistance. If the resistance is too low, the sensor has short-circuited. If the resistance is not consistent with the sensor's resistance characteristics table, the sensor has failed. Refer to Table 5-5.1 in Part 5, 5.1 "Temperature Sensor Resistance Characteristics".
3. Check air side heat exchanger, fan(s) and air outlets for dirt/blockages.

4.15 P9 Troubleshooting

4.15.1 Digital display output

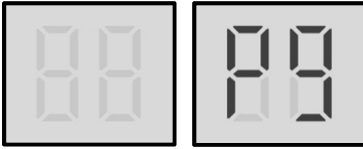

4.15.2 Description

- High temperature difference between water side heat exchanger water inlet and water outlet temperatures protection.
- All units stop running.
- Error code is displayed on main PCB and user interface.

4.15.3 Possible causes

- Temperature sensor not connected properly or has malfunctioned.
- Water piping contains air.
- Insufficient water flow.
- Main PCB damaged.

4.15.4 Procedure

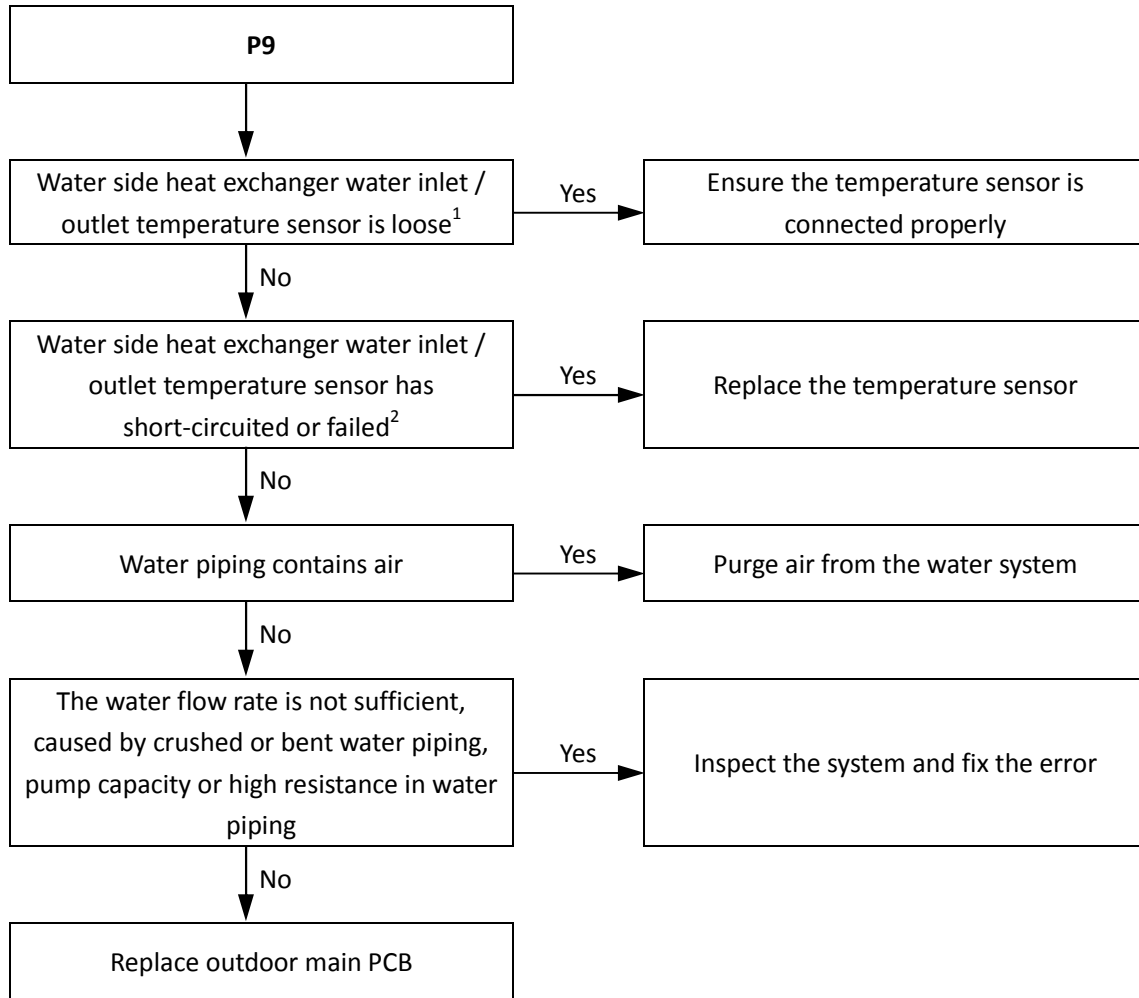

Notes:

1. For 30kW and 60kW units, water side heat exchanger water inlet temperature sensor and water side heat exchanger water outlet temperature sensor connections are port CN31 on the main PCB (labeled 8 in Figure 4-2.1 in Part 4, 2.2 "Main PCB").
2. Measure sensor resistance. If the resistance is too low, the sensor has short-circuited. If the resistance is not consistent with the sensor's resistance characteristics table, the sensor has failed. Refer to Table 5-5.1 in Part 5, 5.1 "Temperature Sensor Resistance Characteristics".

4.16 Pb Troubleshooting

4.16.1 Digital display output

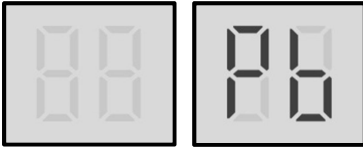

4.16.2 Description

- Water side heat exchanger anti-freeze protection.
- All units stop running.
- Error code is displayed on main PCB and **ANTI.FREEZE** icon is displayed on user interface.

4.16.3 Possible causes

- Normal system protection.
- Temperature sensor not connected properly or has malfunctioned.
- Main PCB damaged.

4.16.4 Procedure

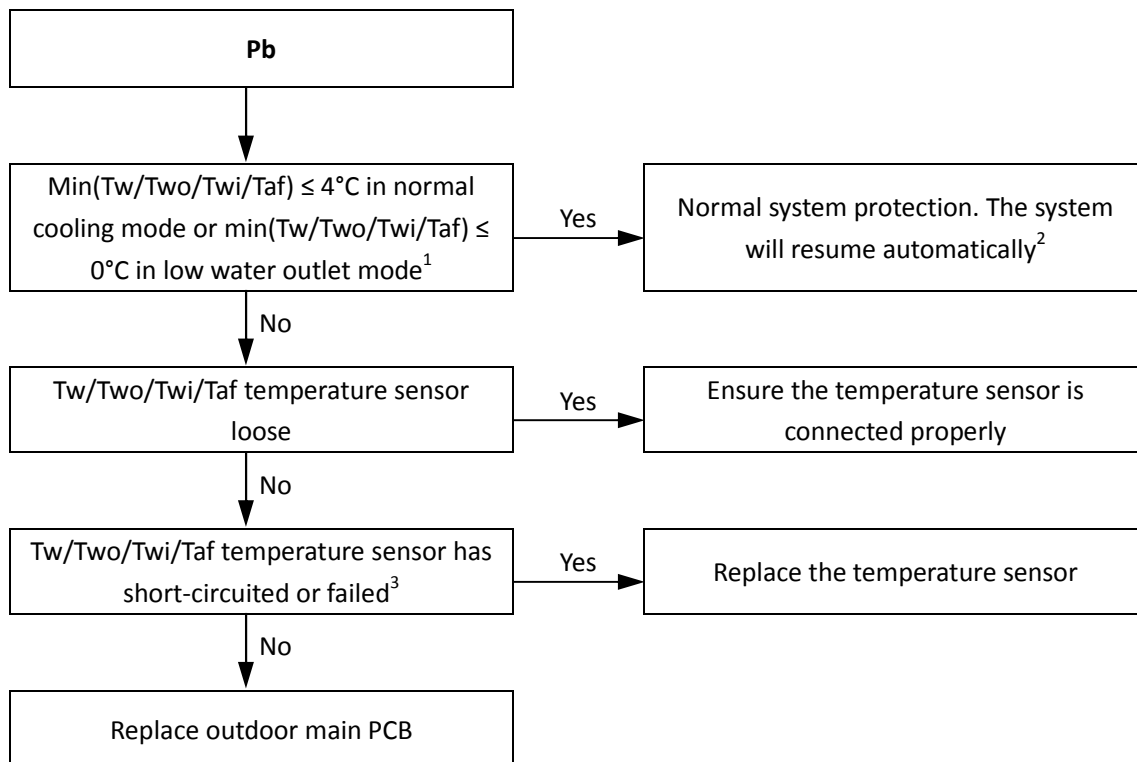

Notes:

1. For 30kW and 60kW units, combined water outlet temperature sensor (Tw), Water side heat exchanger water outlet temperature sensor(Two), water side heat exchanger water inlet temperature sensor (Twi) and water side heat exchanger anti-freezing temperature sensor(Taf, include Taf1 and Taf2) connections are ports CN69 and CN31 on the main PCB (labeled 4 and 8 in in Figure 4-2.1 in Part 4, 2.2 "Main PCB").
2. Refer to Part 3, 6.7 "Water Side Heat Exchanger Anti-freeze Protection Control".
3. Measure sensor resistance. If the resistance is too low, the sensor has short-circuited. If the resistance is not consistent with the sensor's resistance characteristics table, the sensor has failed. Refer to Table 5-5.1 in Part 5, 5.1 "Temperature Sensor Resistance Characteristics".

4.17 PC Troubleshooting

4.17.1 Digital display output

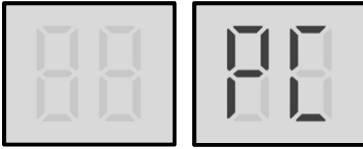

4.17.2 Description

- Water side heat exchanger low pressure protection.
- All units stop running.
- Error code is displayed on main PCB and user interface.

4.17.3 Possible causes

- Low pressure switch not connected properly or has malfunctioned.
- Insufficient refrigerant.
- Low pressure side blockage.
- Poor evaporator heat exchange in heating mode.
- Insufficient water flow in cooling mode.
- Main PCB damaged.

4.17.4 Procedure

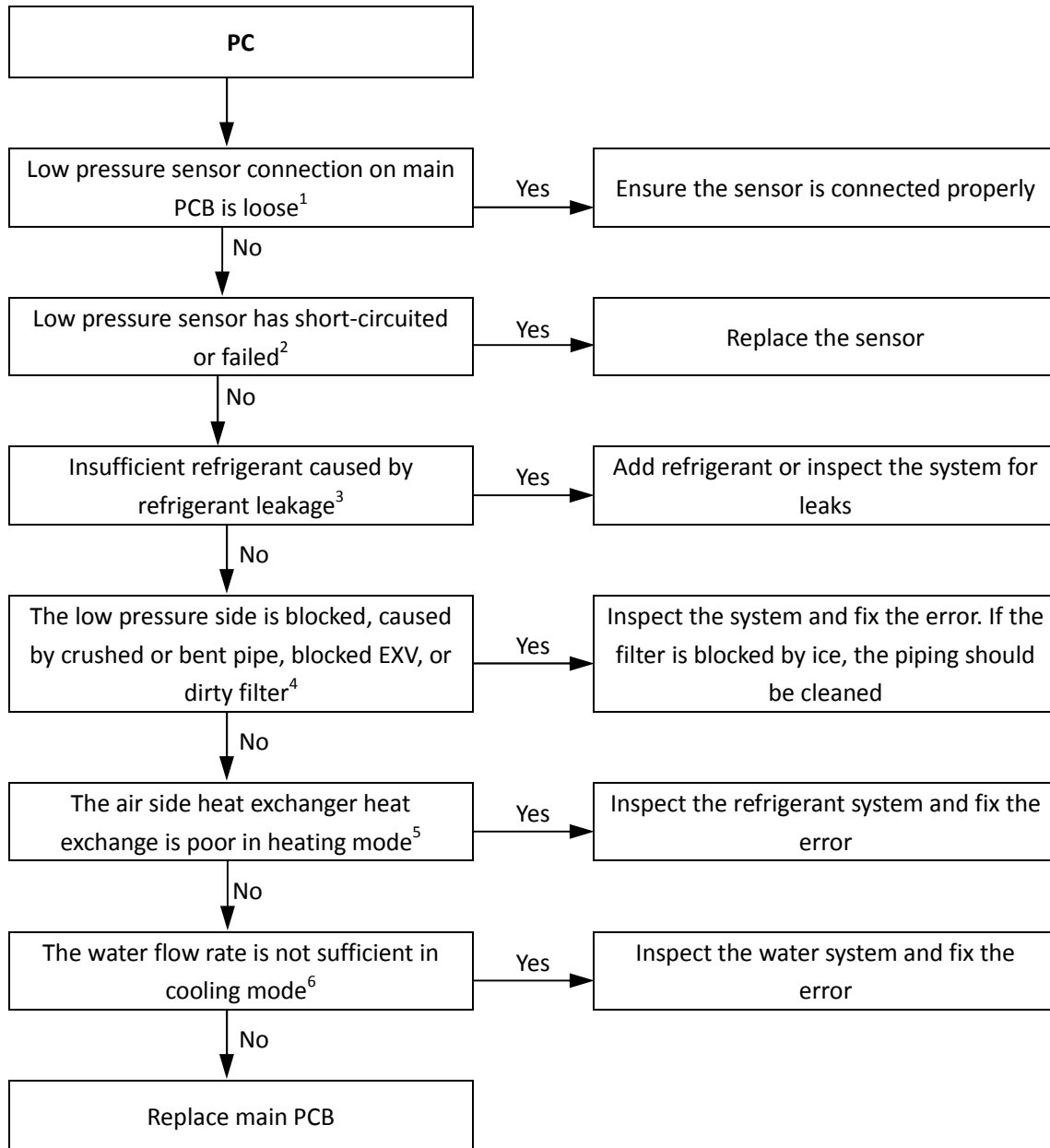

Notes:

1. For 30kW and 60kW units, low pressure sensor connection is port CN16 on the main PCB (labeled 9 in in Figure 4-2.1 in Part 4, 2.2 “Main PCB”) .
2. Measure the resistance among the three terminals of the pressure sensor. If the resistance is of the order of mega Ohms or infinite, the pressure sensor has failed.
3. To check for insufficient refrigerant: An insufficiency of refrigerant causes compressor discharge temperature to be higher than normal, discharge and suction pressures to be lower than normal and compressor current to be lower than normal, and may cause frosting to occur on the suction pipe. These issues disappear once sufficient refrigerant has been charged into the system.
4. A low pressure side blockage causes compressor discharge temperature to be higher than normal, suction pressure to be lower than normal and compressor current to be lower than normal, and may cause frosting to occur on the suction pipe. For normal system parameters.
5. Check air side heat exchanger, fan(s) and air outlets for dirt/blockages.
6. Check water side heat exchanger, water piping, circulator pumps and water flow switch for dirt/blockages.

4.18 PH Troubleshooting

4.18.1 Digital display output

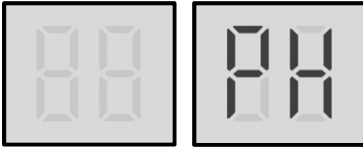

4.18.2 Description

- Ambient temperature too high protection in heating mode.
- All units stop running.
- Error code is displayed on main PCB and user interface.

4.18.3 Possible causes

- Temperature sensor not connected properly or has malfunctioned.
- Actual ambient temperature is higher than 43°C.
- Main PCB damaged.

4.18.4 Procedure

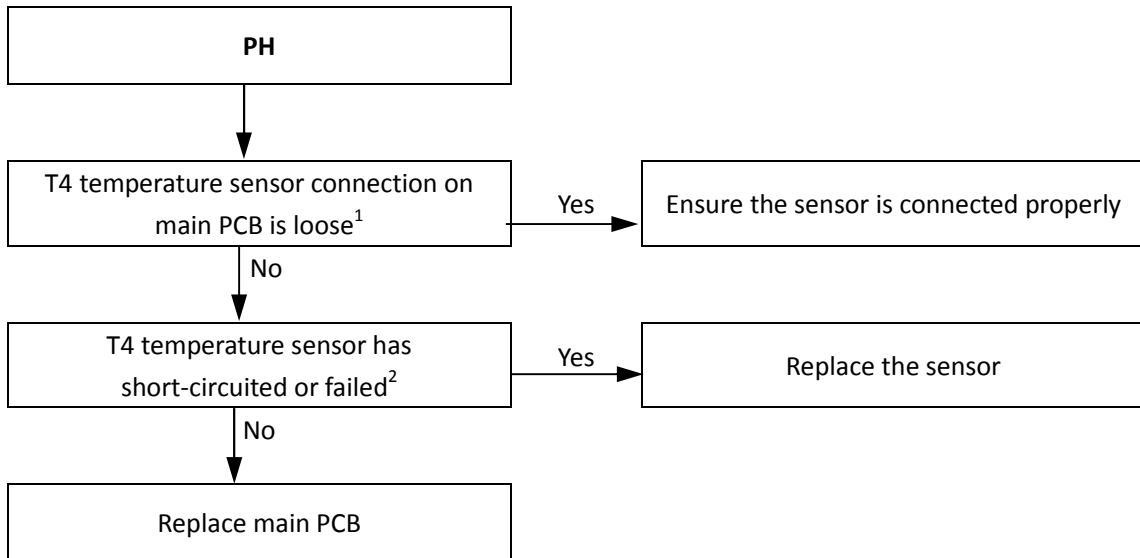

Notes:

1. For 30kW and 60kW units, temperature detection is port CN1 on the main PCB (labeled 10 in in Figure 4-2.1 in Part 4, 2.2 "Main PCB") .
2. Measure sensor resistance. If the resistance is too low, the sensor has short-circuited. If the resistance is not consistent with the sensor's resistance characteristics table, the sensor has failed. Refer to Table 5-5.1 in Part 5, 5.1 "Temperature Sensor Resistance Characteristics".

4.19 PE Troubleshooting

4.19.1 Digital display output

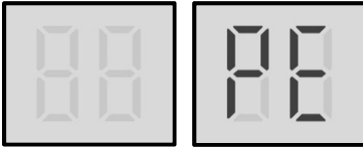

4.19.2 Description

- Water side heat exchanger low temperature protection.
- All units stop running.
- Error code is displayed on main PCB and user interface.

4.19.3 Possible causes

- Temperature sensor not connected properly or has malfunctioned.
- Insufficient refrigerant.
- Low pressure side blockage.
- Poor evaporator heat exchange in heating mode.
- Insufficient water flow in cooling mode.
- Main PCB damaged.

4.19.4 Procedure

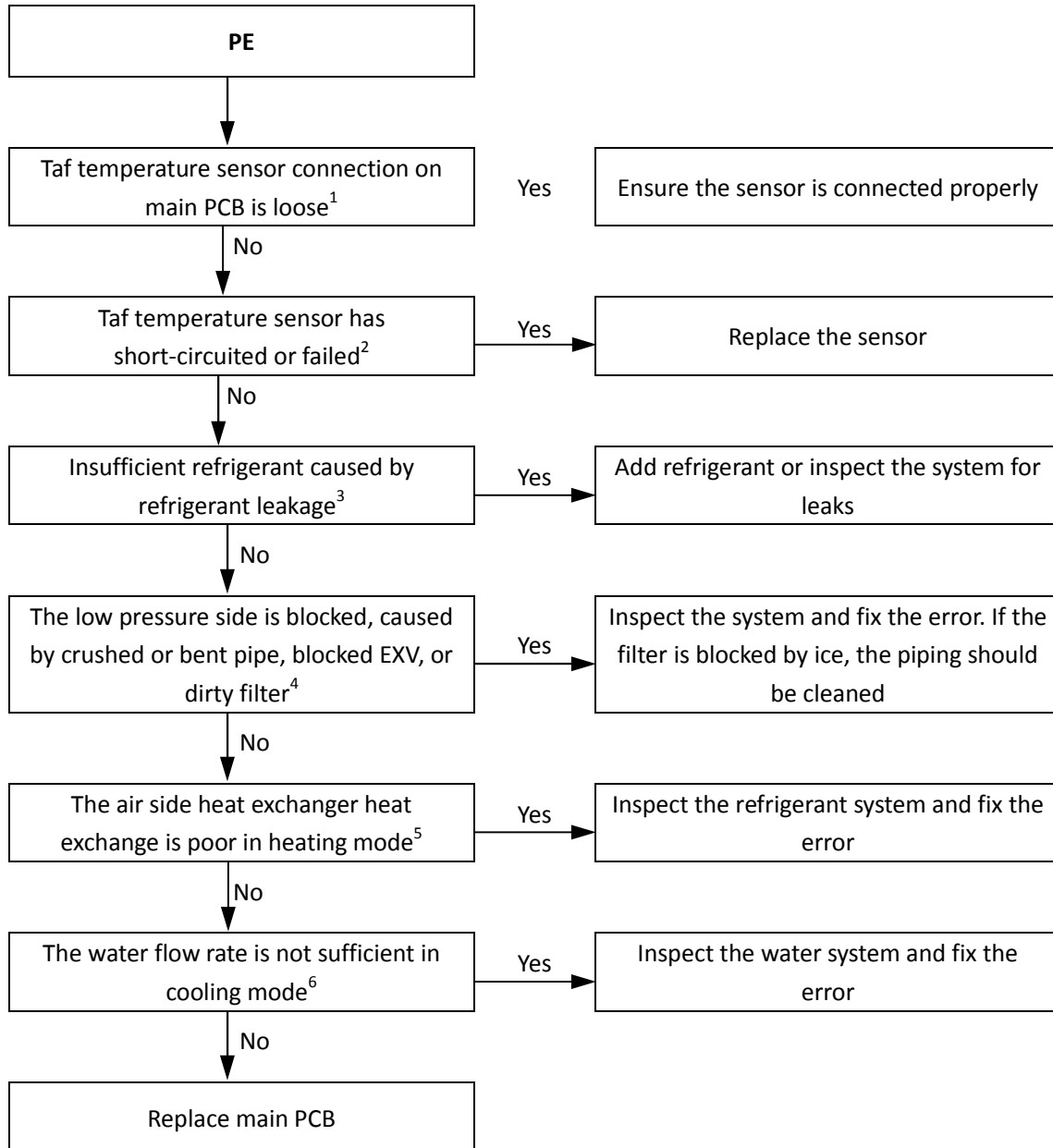

Notes:

1. For 30kW and 60kW units, water side heat exchanger anti-freezing temperature sensor (Taf, include Taf1 and Taf2) connection are ports CN69 and CN31 on the main PCB (labeled 4 and 8 in in Figure 4-2.1 in Part 4, 2.2 "Main PCB").
2. Measure sensor resistance. If the resistance is too low, the sensor has short-circuited. If the resistance is not consistent with the sensor's resistance characteristics table, the sensor has failed. Refer Table 5-5.3 in Part 5, 5.1 "Temperature Sensor Resistance Characteristics".
3. To check for insufficient refrigerant: an insufficiency of refrigerant causes compressor discharge temperature to be higher than normal, discharge and suction pressures to be lower than normal and compressor current to be lower than normal, and may cause frosting to occur on the suction pipe. These issues disappear once sufficient refrigerant has been charged into the system.
4. A low pressure side blockage causes compressor discharge temperature to be higher than normal, suction pressure to be lower than normal and compressor current to be lower than normal, and may cause frosting to occur on the suction pipe. For normal system parameters.
5. Check air side heat exchanger, fan(s) and air outlets for dirt/blockages.
6. Check water side heat exchanger, water piping, circulator pumps and water flow switch for dirt/blockages.

4.20 PL/C7 Troubleshooting

4.20.1 Digital display output

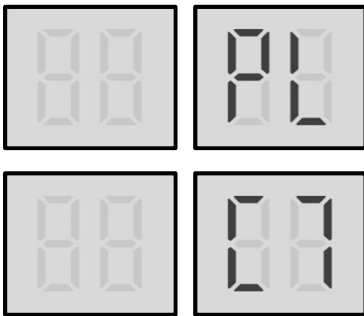

4.20.2 Description

- PL indicates inverter module temperature protection. When the main inverter module temperature rises above 82°C, the system displays PL protection and all the units stop running. When the inverter module temperature drops below 60°C, the compressor enters re-start control
- When a PL error occurs 3 times in 100 minutes, C7 will display, a manual system restart is required before the system can resume operation.
- Error code is displayed on the main PCB and user interface.

4.20.3 Possible causes

- Blocked, dirty or loose heat sink.
- Temperature sensor not connected properly or has malfunctioned.
- Fan motor wiring connection is wrong.
- Main PCB damaged.

4.20.4 Procedure

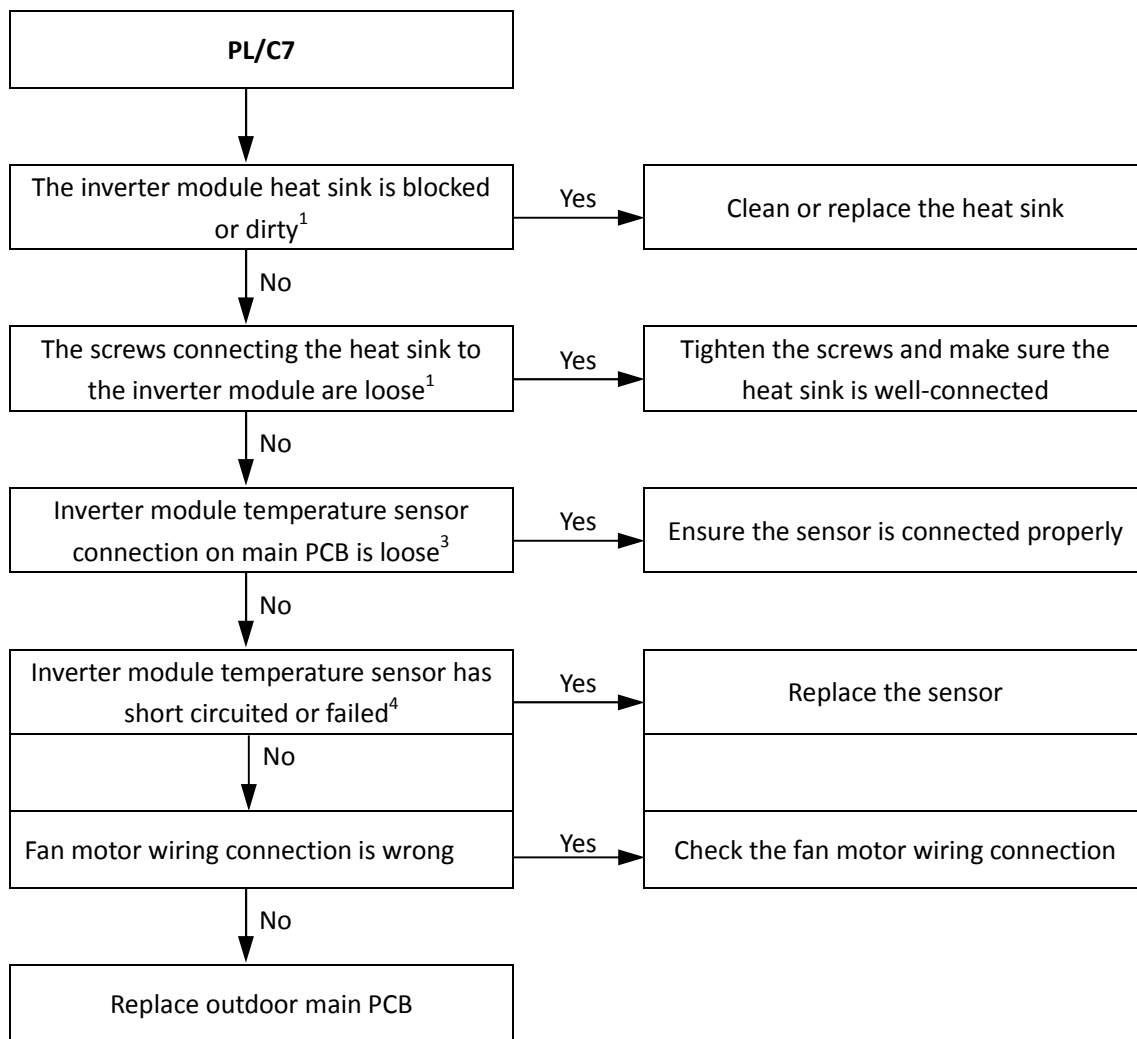

Notes:

1. Refer to Figures 4-1.2 , 4-1.4 and 4-1.6 in Part 4, 1 "Outdoor Unit Electric Control Box Layout".
2. For 30kW and 60kW units, inverter module temperature sensor connection are ports CN3 and CN10 on the main PCB (labeled 7 and 6 in in Figure 4-2.1 in Part 4, 2.2 "Main PCB").
3. Measure sensor resistance. If the resistance is too low, the sensor has short-circuited. If the resistance is not consistent with the sensor's resistance characteristics table, the sensor has failed. Refer to Table 5-5.3 in Part 5, 5.1 "Temperature Sensor Resistance Characteristics".

4.21 PU/FF Troubleshooting

4.21.1 Digital display output

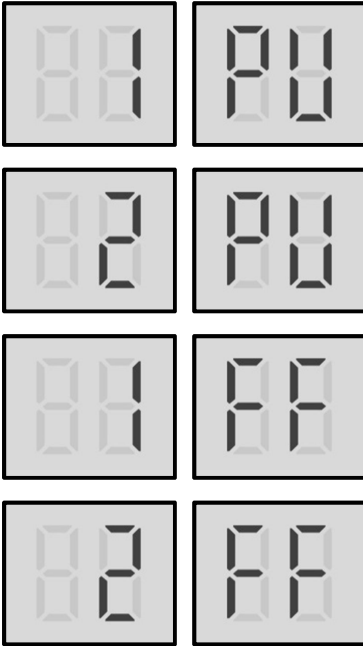

4.21.2 Description

- 1PU/FF indicates fan module A protection.
- 2PU /FF indicates fan module B protection.
- When PU error occurs 10 times in 120 minutes, FF will display, a manual system restart is required before the system can resume operation.
- All units stop running.
- Error code is only displayed on the main PCB and user interface.

4.21.3 Possible causes

- Switch SW1 incorrectly set.
- Power or communication wires not connected properly.
- Fan motor blocked or has failed.
- Power supply abnormal.
- AC filter board damaged.
- Fan module damaged.
- Inverter module PCB damaged.

4.21.4 Procedure

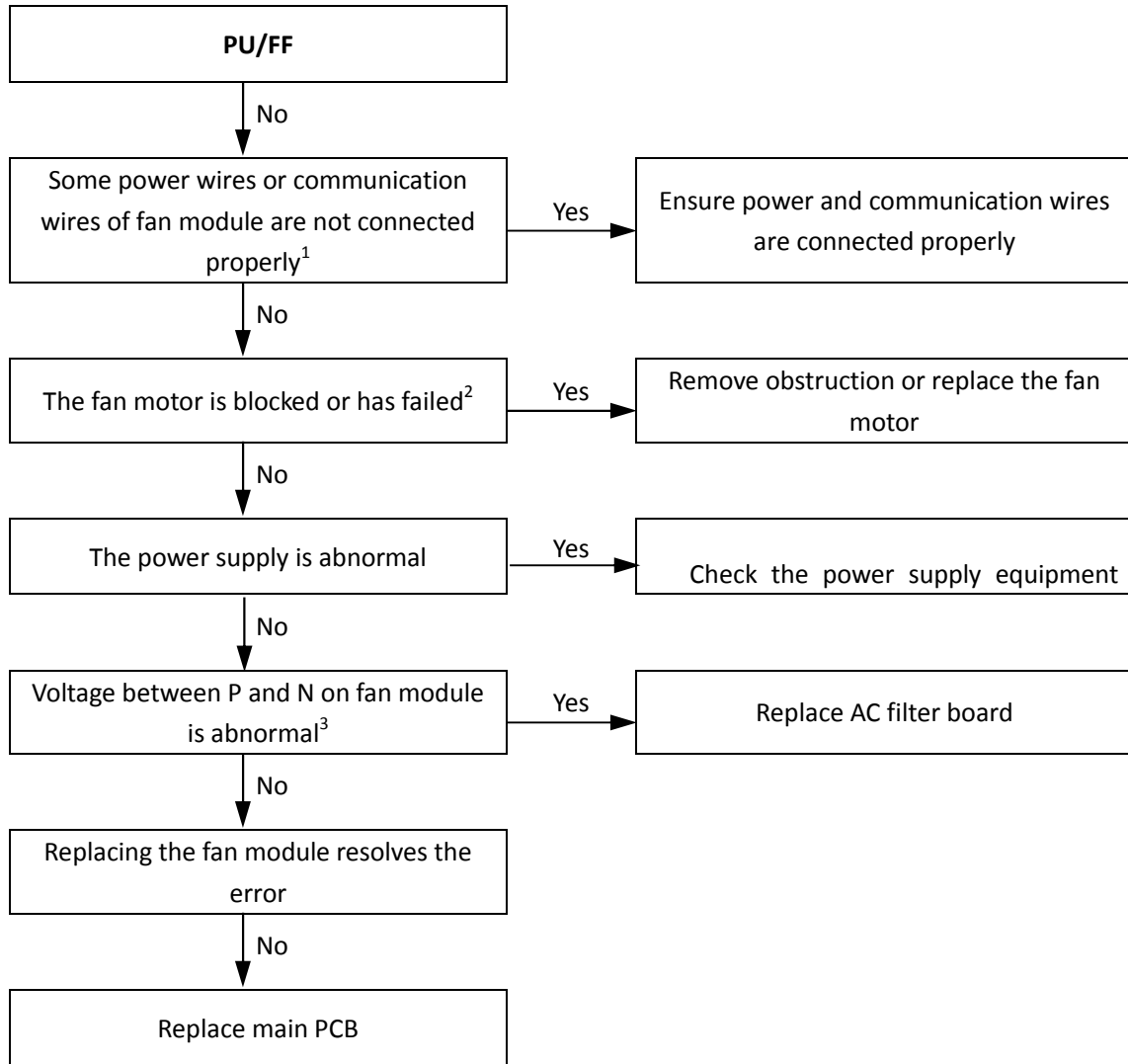

Notes:

1. Refer to Figures 4-1.2, 4-1.4 and 4-1.6 in Part 4, 1 "Outdoor Unit Electric Control Box Layout".
2. Refer to Part 2, 1 "Layout of Functional Components".
3. The normal voltage between P and N on the fan module is 310~340V DC. Refer to Figures 4-1.2 and 4-1.4 in Part 4, 1 "Outdoor Unit Electric Control Box Layout" and to Figure 4-2.6 in Part 4, 2.6 "Fan module power board"

4.22 F0 Troubleshooting

4.22.1 Digital display output

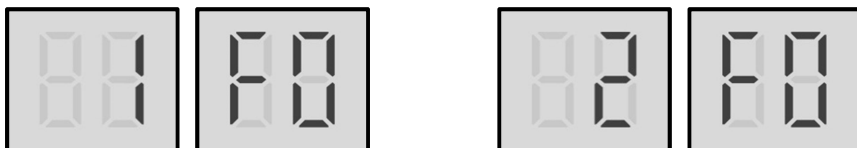

In the error code, 1 representing compressor system A and 2 representing compressor system B.

4.22.2 Description

- 1F0 indicates a communication error between the main control chip and the compressor A inverter driver chip.
- 2F0 indicates a communication error between the main control chip and the compressor B inverter driver chip.
- All units stop running.
- Error code is only displayed on the unit with the error.

4.22.3 Trigger / recover condition

- Trigger condition: Main control chip and inverter driver chip cannot communication for 2 minutes.
- Recover condition: Communication go back to normal.
- Reset method: Resume automatically.

4.22.4 Possible causes

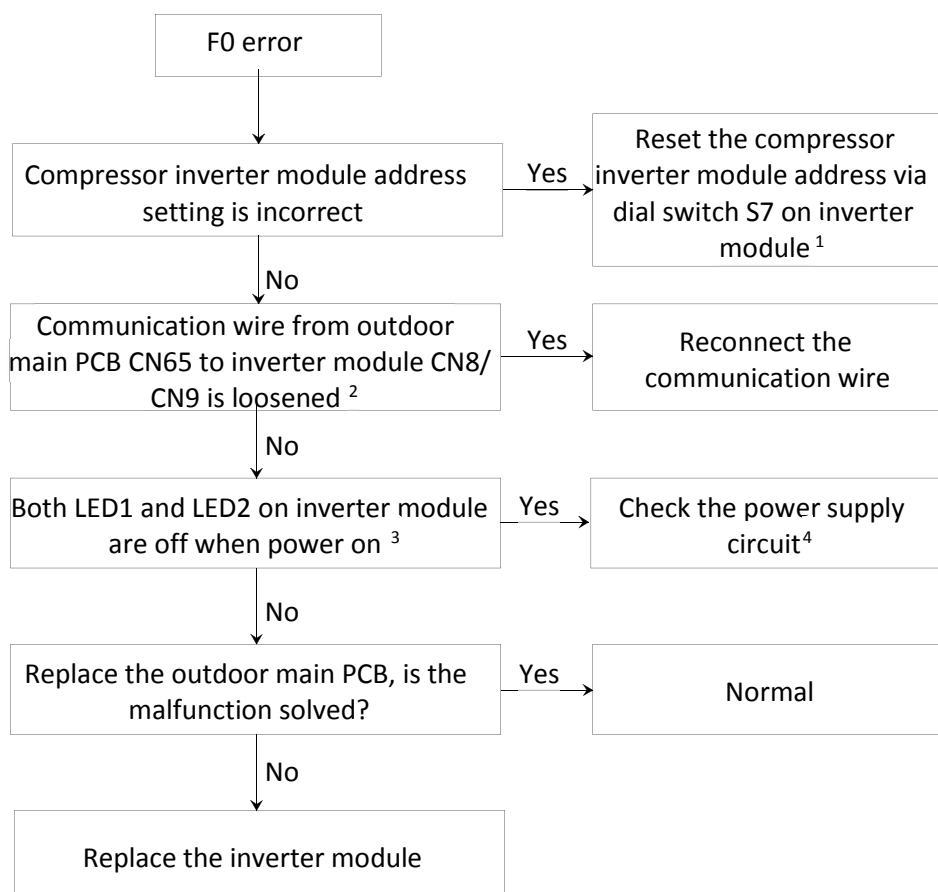

- Incorrect compressor inverter module address setting.
- Loosened communication wiring from the main PCB to the inverter module.
- Bridge rectifier damaged.
- Main PCB damaged.
- Compressor inverter module damaged.

4.22.5 Procedure



Notes:

- Compressor inverter module address is set through dial switch S7 on the inverter module. The compressor inverter module A/B location refers to the wiring diagram.

S7 on inverter module	Inverter module address
	00 for compressor inverter module A
	01 for compressor inverter module B

- Communication wire from outdoor main PCB CN65 to inverter module CN8/CN9.

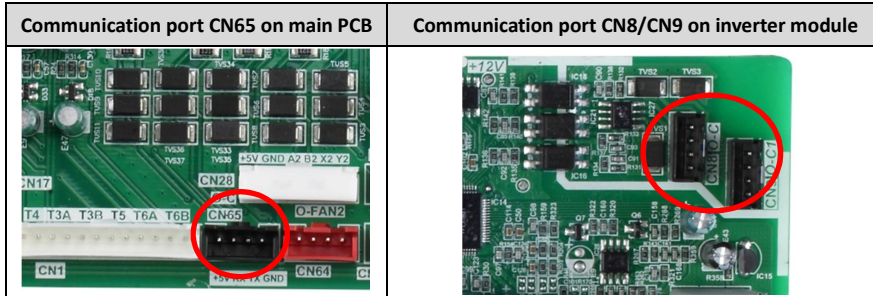

- LED1/2 on inverter module

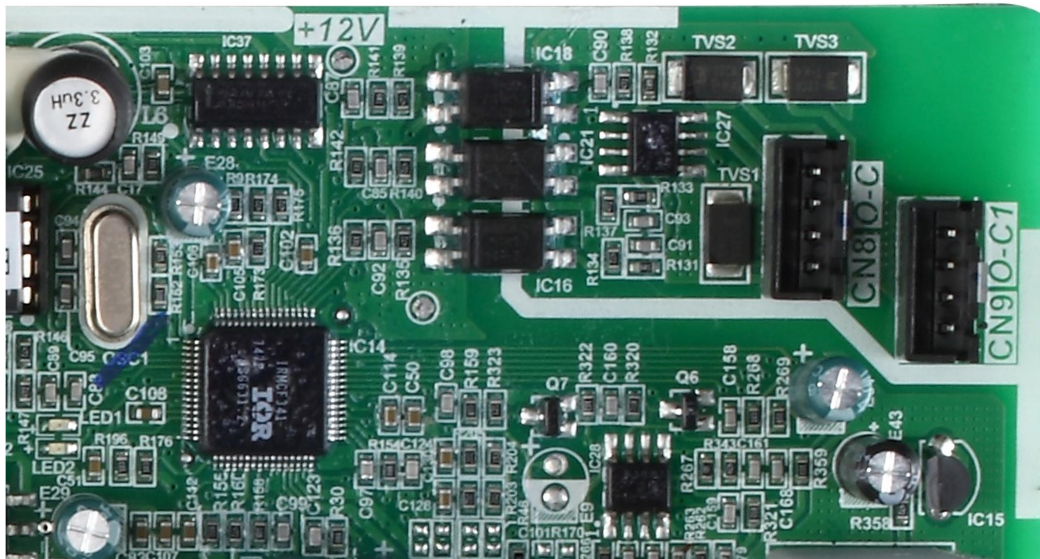

Check the power supply for the compressor inverter module, port CN4 on filter board(30kW) or port CN21 on filter board(60kW), the normal voltage should be DC310~340V; check the high pressure switch connection port CN3 on filter board of 30kW unit and port CN35 on filter board of 60kW unit, the normal resistance should be zero; Check the single phase bridge and fuse on filter board; for 30kW unit, check the connection cable from main PCB port CN58 to filter board port CN6 ; for 60kW unit, check the connection cable from main PCB port CN58 to filter board port CN30 and check the connection cable from main PCB port CN52 to filter board port CN52.

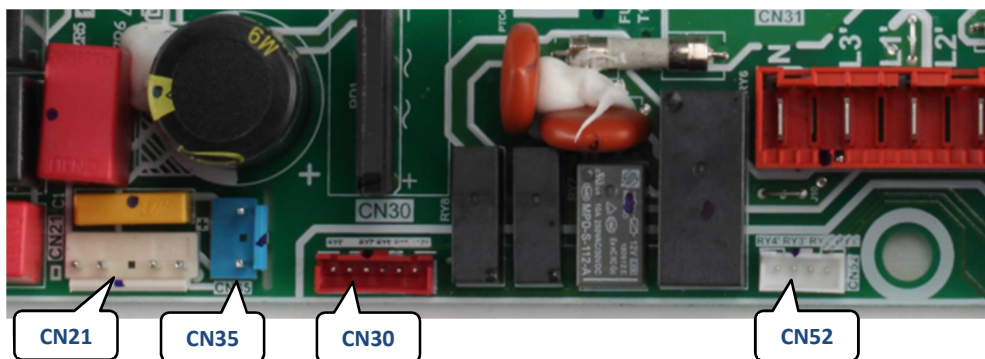

4.23 H5 Troubleshooting

4.23.1 Digital display output

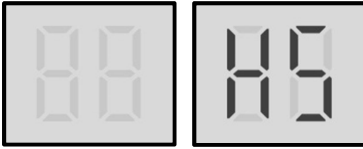

4.23.2 Description

- Abnormal power supply voltage.
- All units stop running.
- Error code is only displayed on main PCB and user interface.

4.23.3 Possible causes

- Outdoor unit power supply voltage at or above 260V or drops below 165V or a phase is missing.
- Loosened wiring within electric control box.
- High voltage circuit error.
- Main PCB damaged.

4.23.4 Procedure

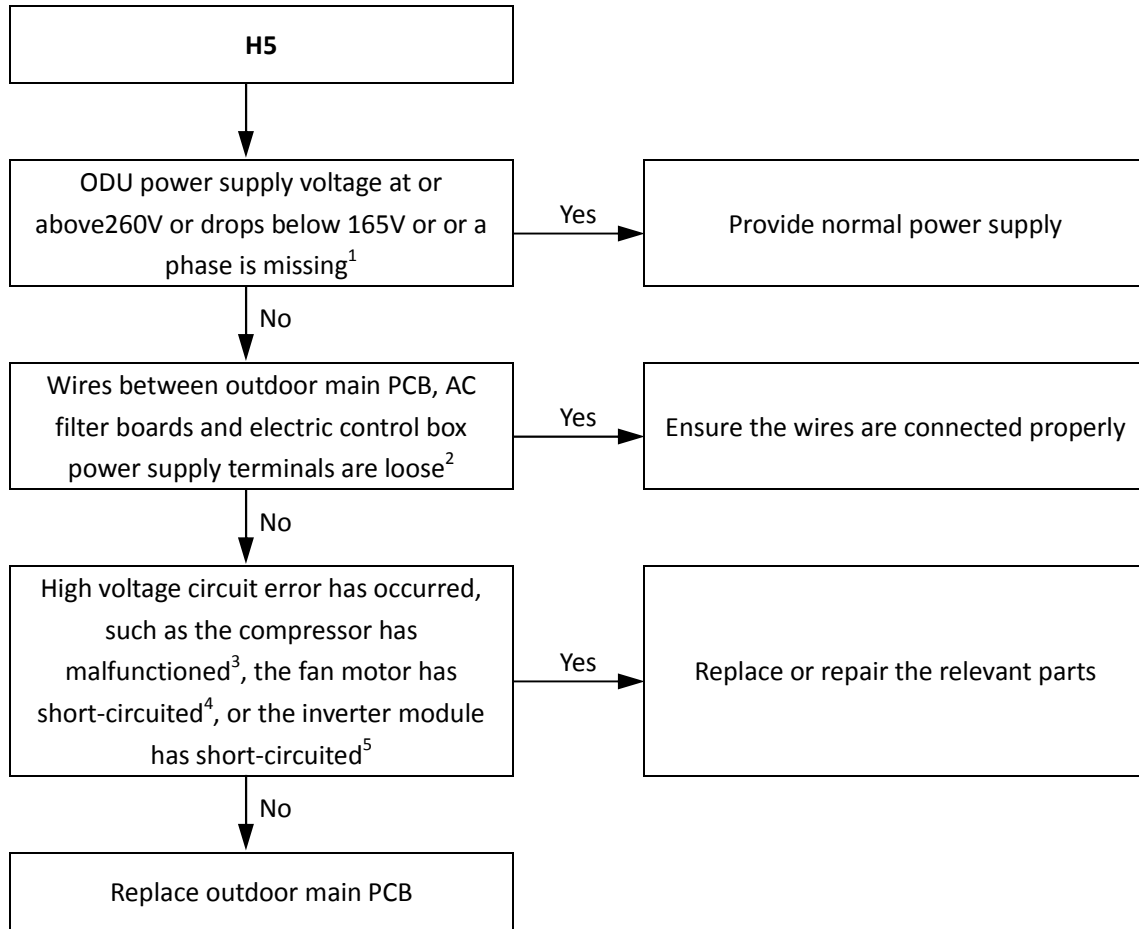

Notes:

1. The normal voltage between A and N, B and N, and C and N is 165-265V.
2. Refer to Figures 4-1.1 to 4-1.4 in Part 4, 1 "Outdoor Unit Electric Control Box Layout".
3. The normal resistances of the inverter compressor are 0.7-1.5Ω among U V W and infinite between each of U V W and ground. If any of the resistances differ from these specifications, the compressor has malfunctioned.
4. The normal resistances of the fan motor coil among U V W are less than 10Ω. If a measured resistance is 0Ω, the fan motor has short-circuited. Refer to Part 2, 1 "Layout of Functional Components".
5. Set a multi-meter to buzzer mode and test any two terminals of P N and U V W of the inverter module. If the buzzer sounds, the inverter module has short-circuited. Refer to Figures 4-1.2 and 4-1.4 in Part 4, 1 "Outdoor Unit Electric Control Box Layout".

4.24 F6 Troubleshooting

4.24.1 Digital display output

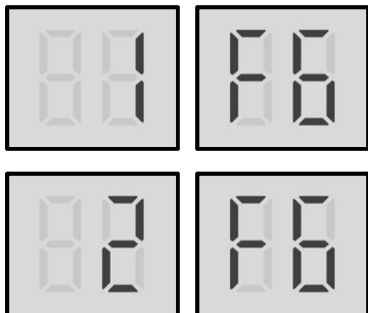

4.24.2 Description

- DC bus voltage protection.
- Only occurred in standby status.
- Error code is displayed on main PCB and user interface.

4.24.3 Possible causes

- Abnormal power supply voltage
- Loosened wiring within electric control box.
- High voltage circuit error.
- AC filter board damaged.
- 3-phase bridge rectifier damaged.
- Compressor Inverter module damaged.

4.24.4 Procedure

F6 refer to P6 protection troubleshooting: xL1 and xL2.

4.25 HE Troubleshooting

4.25.1 Digital display output

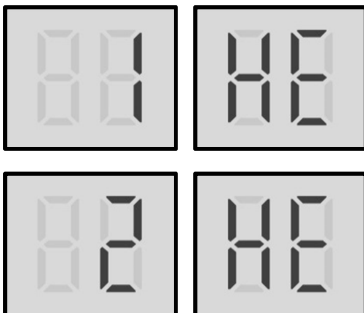

4.25.2 Description

- Electronic expansion valve connection error.
- All units stop running.
- Error code is only displayed on the unit with the error.

4.25.3 Possible causes

- Electronic expansion valve coil not connected properly or has malfunctioned.
- Damaged main PCB.

4.25.4 Procedure

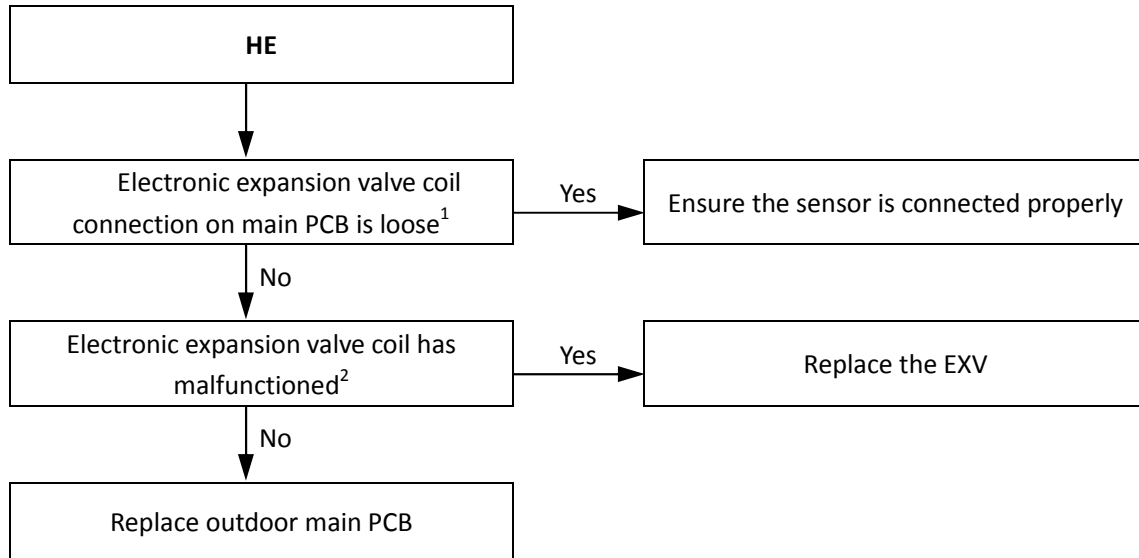

Notes:

1. Electronic expansion valve coil connections are port CN70 on the main PCB (labeled 16 in Figure 4-2.1 in Part 4, 2.2 "Main PCB").
2. The normal resistances between EXV coil wiring terminals RED and white / yellow / orange / blue are 40-50Ω. If any of the resistances differ from the value, the EXV coil has malfunctioned.

Figure 4-4.22: EXV coil wiring terminals

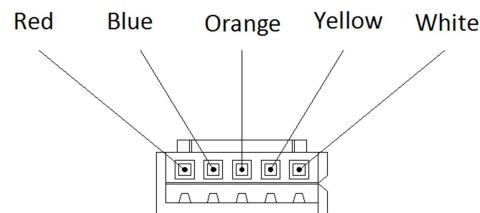

4.26 F2 Troubleshooting

4.26.1 Digital display output

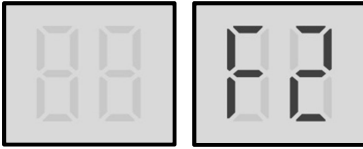

4.26.2 Description

- Insufficient protection of exhaust superheat.
- All units stop running.
- Error code is only displayed on main PCB and user interface.

4.26.3 Possible causes

- Discharge pipe temperature sensor connected properly or has malfunctioned.
- Electronic expansion valve coil not connected properly or has malfunctioned.
- Damaged main PCB.

4.26.4 Procedure

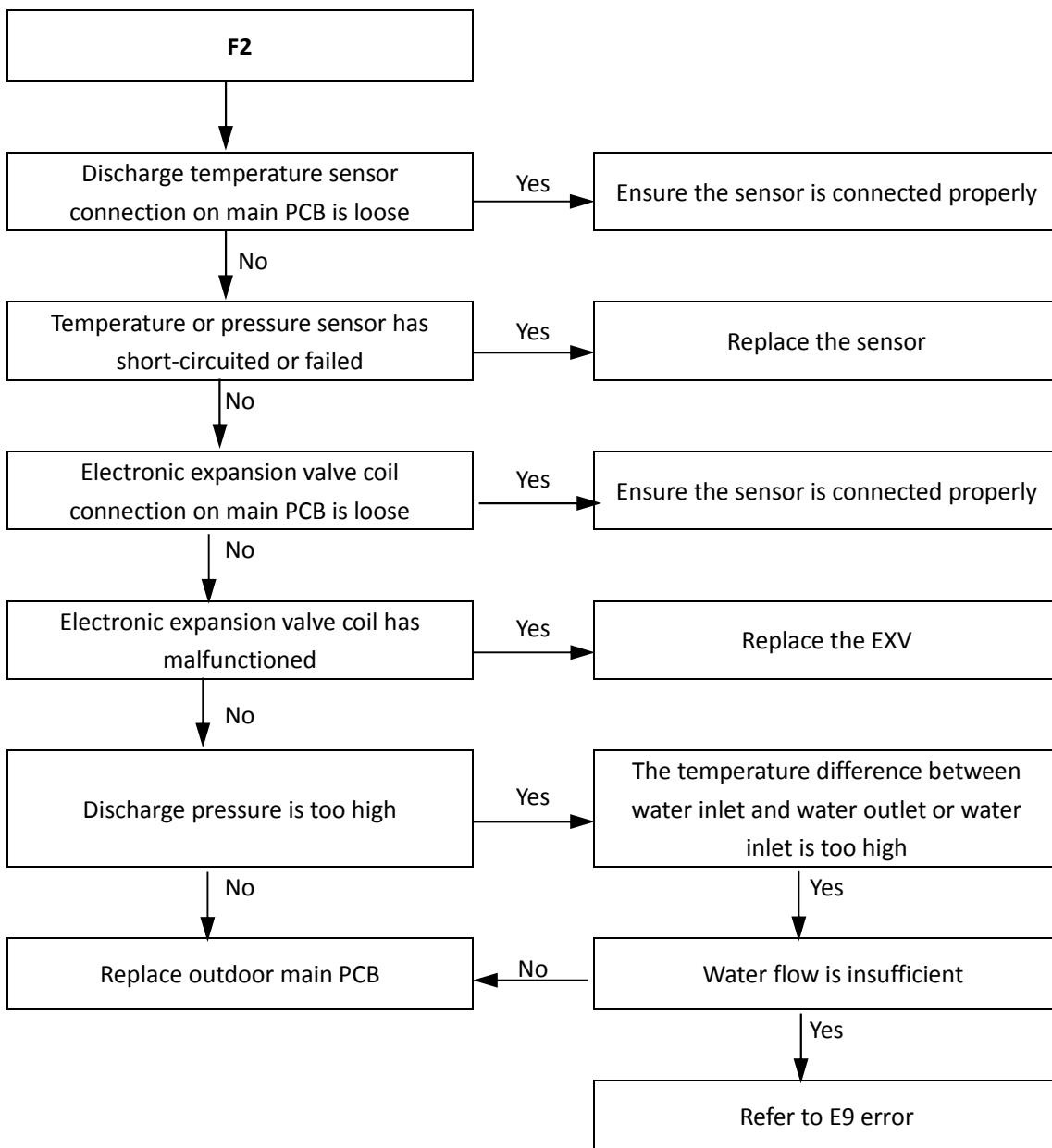

4.27 F4 Troubleshooting

4.27.1 Digital display output

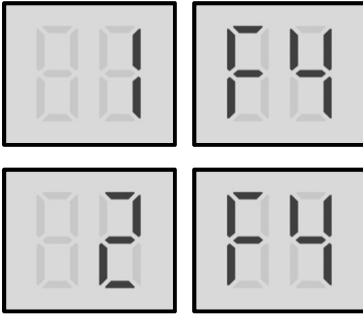

4.27.2 Description

- When a L0 or L1 error occurs 3 times in 60 minutes, F4 will display, a manual system restart is required before the system can resume operation.

4.27.3 Possible causes

- Refer to L0 or L1 error troubleshooting.

4.27.4 Procedure

- Refer to L0 or L1 error troubleshooting.

4.28 FP Troubleshooting

4.28.1 Digital display output

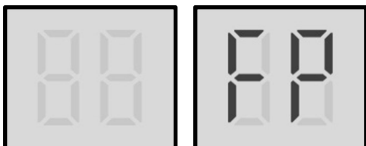

4.28.2 Description

- FP indicates pump in a combination system dial to different status. When the FP displayed, a manual system restart is required before the system can resume operation.
- All units stop running.
- Error code is only displayed on main PCB and user interface.

4.28.3 Possible causes

- The S12_2 of slave units is different with the master unit.
- Main PCB damaged.

4.28.4 Procedure

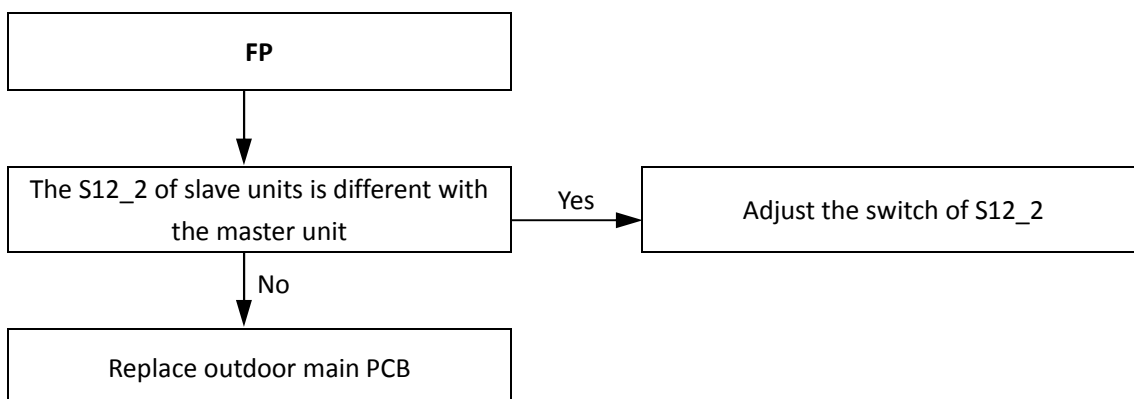

4.29 P3 Troubleshooting

4.29.1 Digital display output

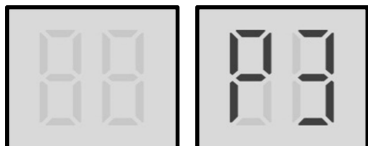

4.29.2 Description

- High temperature protection of ambient temperature sensor in cooling mode. When the ambient temperature is higher than 65°C, the system displays P3 protection and all units stop running. When the ambient temperature returns drops below 58°C, P3 is removed and normal operation resumes.
- All units stop running.
- Error code is displayed on main PCB and user interface.

4.29.3 Possible causes

- Ambient temperature sensor is not connected properly or has malfunctioned.
- Fan motor wiring connection is wrong.
- Poor condenser heat exchange.
- Fan motor damaged.
- Main PCB damaged.

4.29.4 Procedure

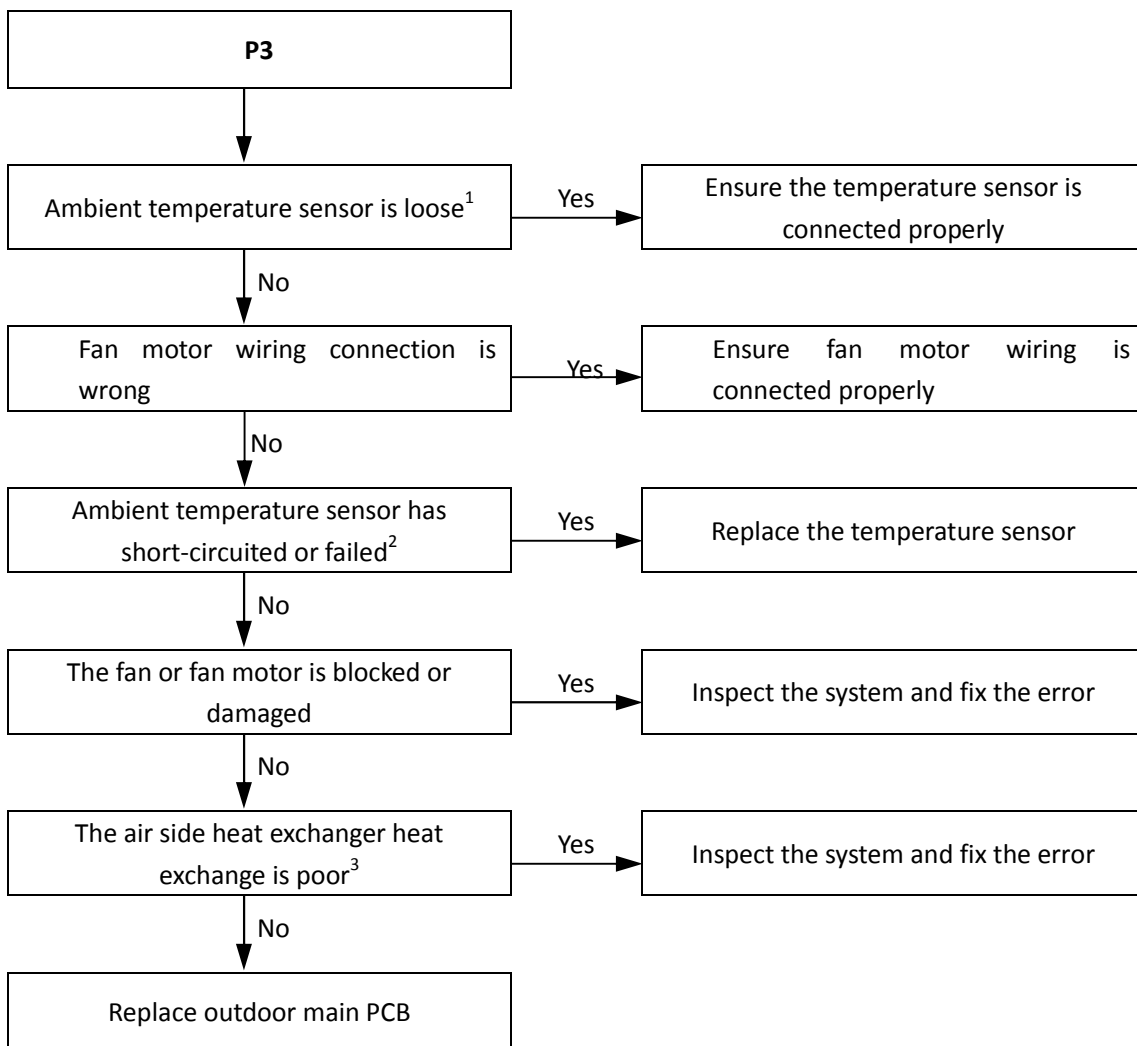

Notes:

1. For 30kW and 60kW units, ambient temperature sensor connection port is CN1 on the main PCB (labeled 10 in Figure 4-2.1 in Part 4, 2.2 “Main PCB”).
2. Measure sensor resistance. If the resistance is too low, the sensor has short-circuited. If the resistance is not consistent with the sensor’s resistance characteristics table, the sensor has failed. Refer to Table 5-5.1 in Part 5, 5.1 “Temperature Sensor Resistance Characteristics”.
3. Check air side heat exchanger, fan(s) and air outlets for dirt/blockages.

5 Appendix to Part 5

5.1 Temperature Sensor Resistance Characteristics

Table 5-5.1: Outdoor ambient temperature sensor and outdoor heat exchanger or plate heat exchanger temperature sensor resistance characteristics

Temperature (°C)	Resistance (kΩ)	Temperature (°C)	Resistance (kΩ)	Temperature (°C)	Resistance (kΩ)	Temperature (°C)	Resistance (kΩ)
-20	115.3	20	12.64	60	2.358	100	0.6297
-19	108.1	21	12.06	61	2.272	101	0.6115
-18	101.5	22	11.50	62	2.191	102	0.5939
-17	96.34	23	10.97	63	2.112	103	0.5768
-16	89.59	24	10.47	64	2.037	104	0.5604
-15	84.22	25	10.00	65	1.965	105	0.5445
-14	79.31	26	9.551	66	1.896	106	0.5291
-13	74.54	27	9.124	67	1.830	107	0.5143
-12	70.17	28	8.720	68	1.766	108	0.4999
-11	66.09	29	8.336	69	1.705	109	0.4860
-10	62.28	30	7.971	70	1.647	110	0.4726
-9	58.71	31	7.624	71	1.591	111	0.4596
-8	56.37	32	7.295	72	1.537	112	0.4470
-7	52.24	33	6.981	73	1.485	113	0.4348
-6	49.32	34	6.684	74	1.435	114	0.4230
-5	46.57	35	6.400	75	1.387	115	0.4116
-4	44.00	36	6.131	76	1.341	116	0.4006
-3	41.59	37	5.874	77	1.291	117	0.3899
-2	39.82	38	5.630	78	1.254	118	0.3796
-1	37.20	39	5.397	79	1.2133	119	0.3695
0	35.20	40	5.175	80	1.174	120	0.3598
1	33.33	41	4.964	81	1.136	121	0.3504
2	31.56	42	4.763	82	1.100	122	0.3413
3	29.91	43	4.571	83	1.064	123	0.3325
4	28.35	44	4.387	84	1.031	124	0.3239
5	26.88	45	4.213	85	0.9982	125	0.3156
6	25.50	46	4.046	86	0.9668	126	0.3075
7	24.19	47	3.887	87	0.9366	127	0.2997
8	22.57	48	3.735	88	0.9075	128	0.2922
9	21.81	49	3.590	89	0.8795	129	0.2848
10	20.72	50	3.451	90	0.8525	130	0.2777
11	19.69	51	3.318	91	0.8264	131	0.2708
12	18.72	52	3.192	92	0.8013	132	0.2641
13	17.80	53	3.071	93	0.7771	133	0.2576
14	16.93	54	2.959	94	0.7537	134	0.2513
15	16.12	55	2.844	95	0.7312	135	0.2451
16	15.34	56	2.738	96	0.7094	136	0.2392
17	14.62	57	2.637	97	0.6884	137	0.2334
18	13.92	58	2.540	98	0.6682	138	0.2278
19	13.26	59	2.447	99	0.6486	139	0.2223

Table 5-5.2: Compressor top temperature sensor and discharge pipe temperature sensor resistance characteristics

Temperature (°C)	Resistance (kΩ)	Temperature (°C)	Resistance (kΩ)	Temperature (°C)	Resistance (kΩ)	Temperature (°C)	Resistance (kΩ)
-20	542.7	20	68.66	60	13.59	100	3.702
-19	511.9	21	65.62	61	13.11	101	3.595
-18	483.0	22	62.73	62	12.65	102	3.492
-17	455.9	23	59.98	63	12.21	103	3.392
-16	430.5	24	57.37	64	11.79	104	3.296
-15	406.7	25	54.89	65	11.38	105	3.203
-14	384.3	26	52.53	66	10.99	106	3.113
-13	363.3	27	50.28	67	10.61	107	3.025
-12	343.6	28	48.14	68	10.25	108	2.941
-11	325.1	29	46.11	69	9.902	109	2.860
-10	307.7	30	44.17	70	9.569	110	2.781
-9	291.3	31	42.33	71	9.248	111	2.704
-8	275.9	32	40.57	72	8.940	112	2.630
-7	261.4	33	38.89	73	8.643	113	2.559
-6	247.8	34	37.30	74	8.358	114	2.489
-5	234.9	35	35.78	75	8.084	115	2.422
-4	222.8	36	34.32	76	7.820	116	2.357
-3	211.4	37	32.94	77	7.566	117	2.294
-2	200.7	38	31.62	78	7.321	118	2.233
-1	190.5	39	30.36	79	7.086	119	2.174
0	180.9	40	29.15	80	6.859	120	2.117
1	171.9	41	28.00	81	6.641	121	2.061
2	163.3	42	26.90	82	6.430	122	2.007
3	155.2	43	25.86	83	6.228	123	1.955
4	147.6	44	24.85	84	6.033	124	1.905
5	140.4	45	23.89	85	5.844	125	1.856
6	133.5	46	22.89	86	5.663	126	1.808
7	127.1	47	22.10	87	5.488	127	1.762
8	121.0	48	21.26	88	5.320	128	1.717
9	115.2	49	20.46	89	5.157	129	1.674
10	109.8	50	19.69	90	5.000	130	1.632
11	104.6	51	18.96	91	4.849		
12	99.69	52	18.26	92	4.703		
13	95.05	53	17.58	93	4.562		
14	90.66	54	16.94	94	4.426		
15	86.49	55	16.32	95	4.294		
16	82.54	56	15.73	96	4.167		
17	78.79	57	15.16	97	4.045		
18	75.24	58	14.62	98	3.927		
19	71.86	59	14.09	99	3.812		

Table 5-5.3: Inverter module temperature sensor resistance characteristics

Temperature (°C)	Resistance (kΩ)	Temperature (°C)	Resistance (kΩ)	Temperature (°C)	Resistance (kΩ)	Temperature (°C)	Resistance (kΩ)
-30	971.4	10	109.0	50	19.70	90	5.000
-29	912.8	11	103.9	51	18.97	91	4.855
-28	858.2	12	99.02	52	18.26	92	4.705
-27	807.3	13	94.44	53	17.59	93	4.566
-26	759.7	14	90.11	54	16.94	94	4.431
-25	715.3	15	86.00	55	16.32	95	4.301
-24	673.6	16	82.09	56	15.73	96	4.176
-23	634.7	17	78.38	57	15.16	97	4.055
-22	598.2	18	74.87	58	14.62	98	3.938
-21	564.1	19	71.53	59	14.10	99	3.825
-20	532.2	20	68.36	60	13.60	100	3.716
-19	502.2	21	65.34	61	13.12	101	3.613
-18	474.1	22	62.47	62	12.65	102	3.514
-17	447.7	23	59.75	63	12.22	103	3.418
-16	423.0	24	57.17	64	11.79	104	3.326
-15	399.8	25	54.71	65	11.39	105	3.235
-14	378.0	26	52.36	66	10.99	106	3.148
-13	357.5	27	50.13	67	10.62	107	3.063
-12	338.2	28	48.01	68	10.25	108	2.982
-11	320.1	29	45.99	69	9.909	109	2.902
-10	303.1	30	44.07	70	9.576	110	2.826
-9	287.1	31	42.23	71	9.253	111	2.747
-8	272.0	32	40.48	72	8.947	112	2.672
-7	257.8	33	38.81	73	8.646	113	2.599
-6	244.4	34	37.23	74	8.362	114	2.528
-5	231.9	35	35.71	75	8.089	115	2.460
-4	220.0	36	34.27	76	7.821	116	2.390
-3	208.7	37	32.89	77	7.569	117	2.322
-2	198.2	38	31.58	78	7.323	118	2.256
-1	188.2	39	30.33	79	7.088	119	2.193
0	178.8	40	29.13	80	6.858	120	2.132
1	169.9	41	27.98	81	6.640	121	2.073
2	161.5	42	26.89	82	6.432	122	2.017
3	153.6	43	25.85	83	6.230	123	1.962
4	146.1	44	24.85	84	6.033	124	1.910
5	139.1	45	23.90	85	5.847	125	1.859
6	132.3	46	22.98	86	5.667		
7	126.0	47	22.10	87	5.492		
8	120.0	48	21.26	88	5.322		
9	114.3	49	20.47	89	5.159		

NOTE CONCERNING PROTECTION OF ENVIRONMENT



This product must not be disposed of via normal household waste after its service life, but must be taken to a collection station for the recycling of electrical and electronic devices. The symbol on the product, the operating instructions or the packaging indicate such disposal procedures. The materials are recyclable in accordance with their respective symbols. By means of re-use, material recycling or any other form of recycling old appliances you are making an important contribution to the protection of our environment. Please ask your local council where your nearest disposal station is located.

INFORMATION CONCERNING USED REFRIGERANT MEDIUM

This unit is containing fluorinated gases included in the Kyoto protocol. The maintenance and the liquidation must be carried out by qualified personnel.

Type of refrigerant: R32

The quantity of the refrigerant: please see the unit label.

The value GWP: 675 (1 kg R32 = 0,675 t CO₂ eq)

GWP = Global Warming Potential



Appliance filled with flammable gas R32.

In case of quality problem or other please contact your local supplier or authorized service center.

Emergency number: 112

PRODUCER

SINCLAIR CORPORATION Ltd.

1-4 Argyll St.

London W1F 7LD

Great Britain

www.sinclair-world.com

This product was manufactured in China (Made in China).

REPRESENTATIVE

SINCLAIR Global Group s.r.o.

Purkynova 45

612 00 Brno

Czech Republic

TECHNICAL SUPPORT

SINCLAIR Global Group s.r.o.

Purkynova 45

612 00 Brno

Czech Republic

Tel.: +420 800 100 285

Fax: +420 541 590 124

www.sinclair-solutions.com

info@sinclair-solutions.com

