

AIR-COOLED MODULAR CHILLER UNIT

SERVICE MANUAL

SCV-750EB

SCV-900EB

SCV-1400EB

SCV-1800EB



SINCLAIR
AIR CONDITIONING

CONTENTS

Part 1 General Information.....	3
Part 2 Component Layout and Refrigerant Circuits	7
Part 3 Control	25
Part 4 Diagnosis and Troubleshooting.....	43

Part 1

General Information

1	Unit Capacities and External Appearance.....	4
2	Water outlet temperature range.....	4

1 Unit Capacities and External Appearance

Model	SCV-750EB	SCV-900EB	SCV-1400EB	SCV-1800EB
Power supply	380-415V/3Ph/50Hz	380-415V/3Ph/50Hz	380-415V/3Ph/50Hz	380-415V/3Ph/50Hz
Appearance				

2 Water outlet temperature range

2.1 Cooling operating range

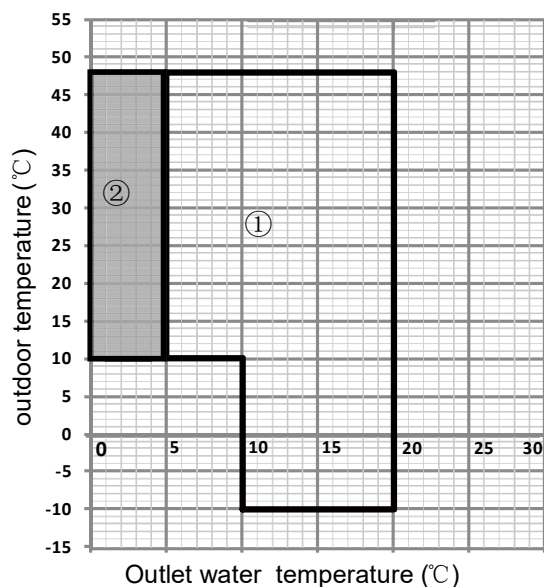

Notes:

- ① Normal mode
- ② Low leaving water temperature mode

Low leaving water temperature mode can be set through wired controller, please refer to the Operation Manual for details. If low leaving water temperature function is effective, the operation range will extend to the red frame above. When the set temperature is less than 5°C, antifreeze liquid (concentration above 15%) should be added in the water system, otherwise the unit will be damaged.

- ③ T4: Ambient temperature
- Two: Leaving water temperature

2.2 Heating operating range

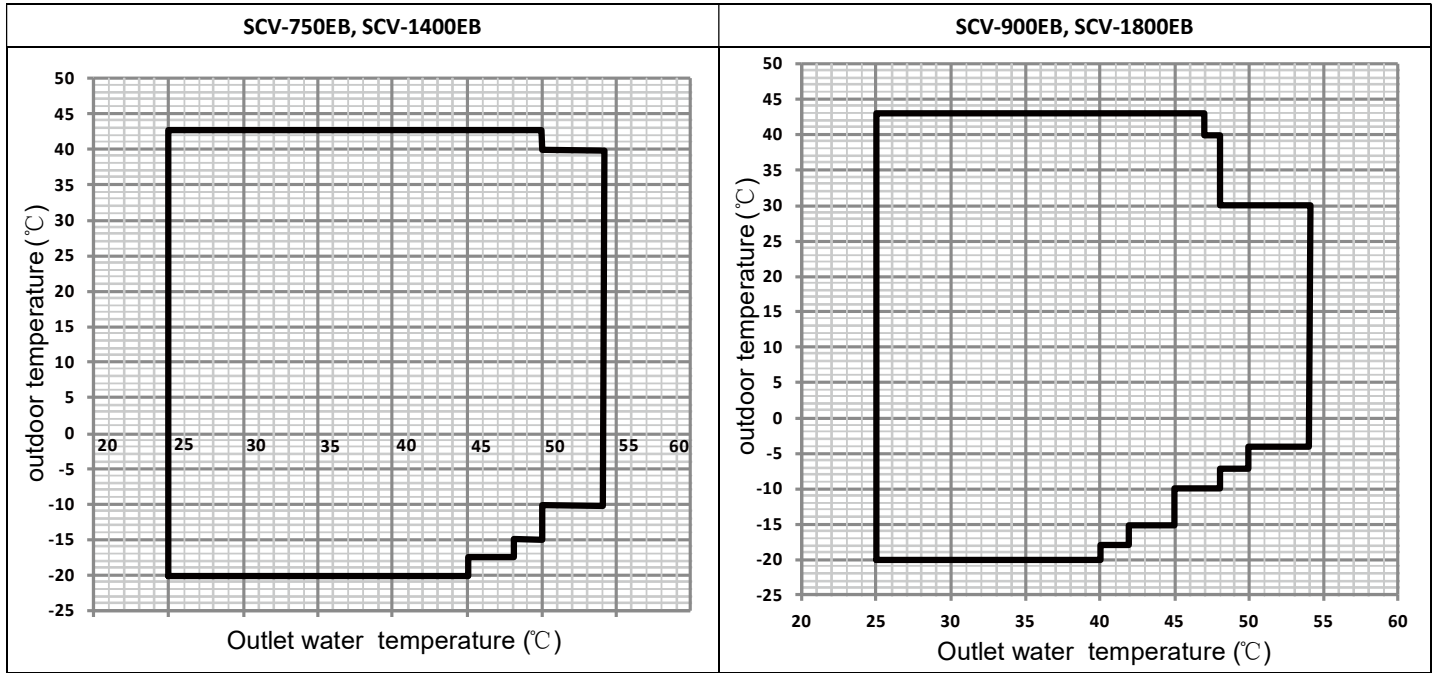

Part 2

Component Layout and Refrigerant Circuits

1 Layout of Functional Components.....	8
2 Piping Diagrams	12
3 Refrigerant Flow Diagrams	21

1 Layout of Functional Components

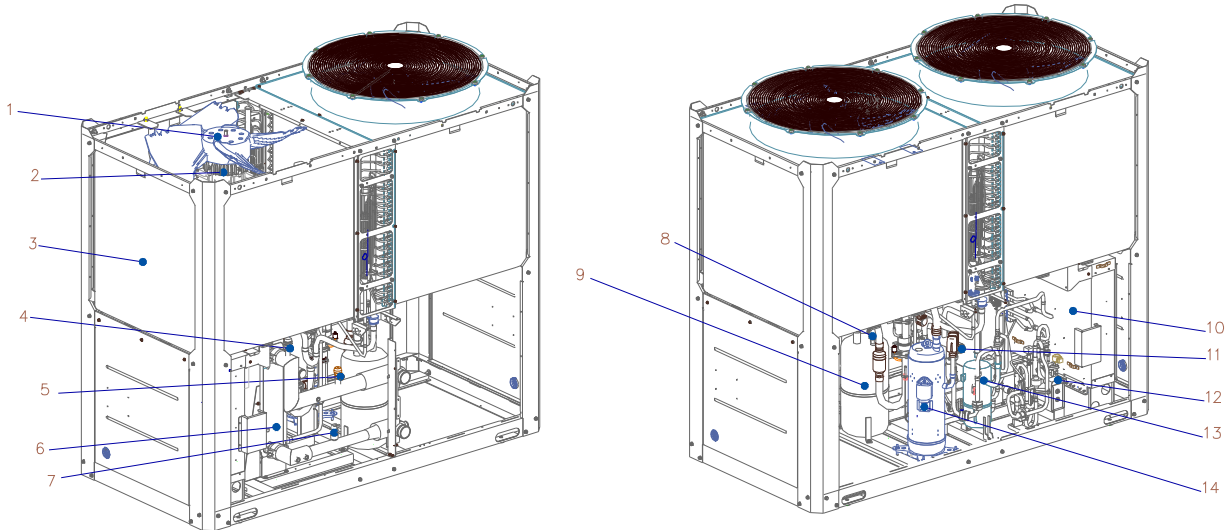

Component list of SCV-750EB					
1	Axial fan	6	Plate heating exchanger	11	Four-way valve
2	Brushless DC Motor	7	Flow switch	12	Plate heating exchanger
3	Condenser	8	Safety valve (Refrigerant side)	13	Oil separator
4	Exhaust valve	9	Gas-liquid separator	14	DC inverter scroll compressor
5	Safety valve (Water side)	10	Electric control box		

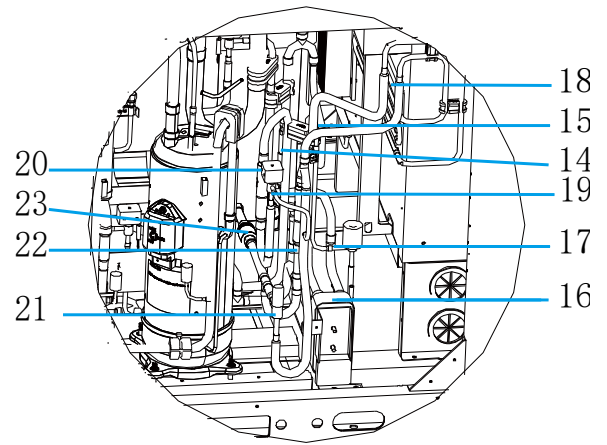
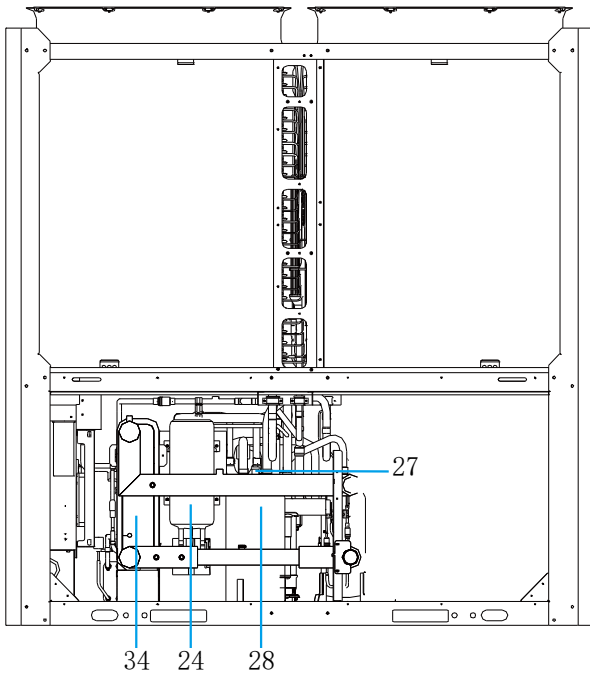
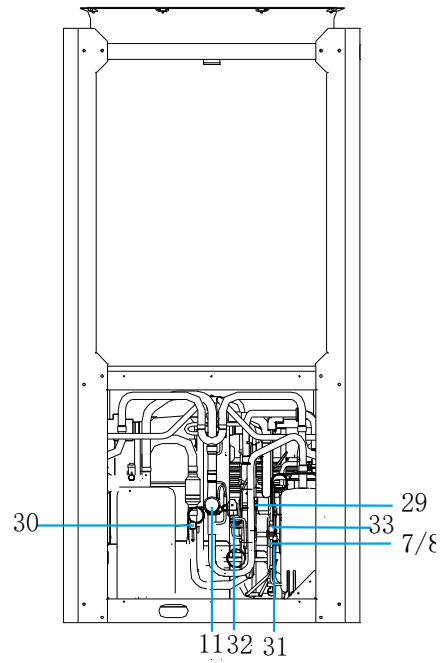
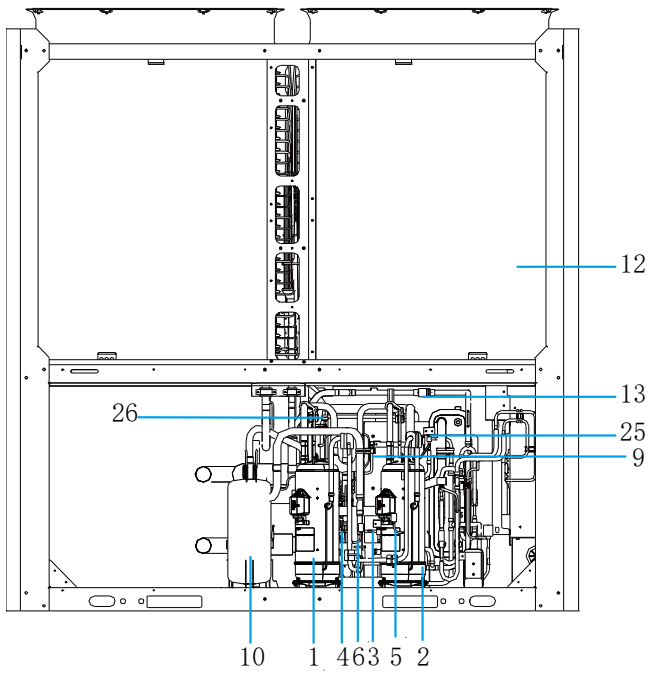

Component list of SCV-900EB

1	Compressor 1	13	Filter	24	Liquid storage tank
2	Compressor 2	14	One-way valve	25	Solenoid valve suit
3	Vapor injection solenoid valve 1	15	Electronic expansion valve	26	Pressure sensor
4	Vapor injection solenoid valve 2	16	Plate heating exchanger	27	Safety valve
5/6	High pressure switch	17	Electronic expansion valve	28	Gas-liquid separator
7/8	Filter	18	Heat sink assembly	29	Meter connector
9	Meter connector	19	Single pass solenoid valve suit	30	Low pressure switch
10	Oil separator	20/22	One way valve	31/33	Filter
11	4-way valve	21	Electronic expansion valve	32	Solenoid valve suit(Oil balance)
12	Condenser	23	Filter	34	Plate heat exchanger

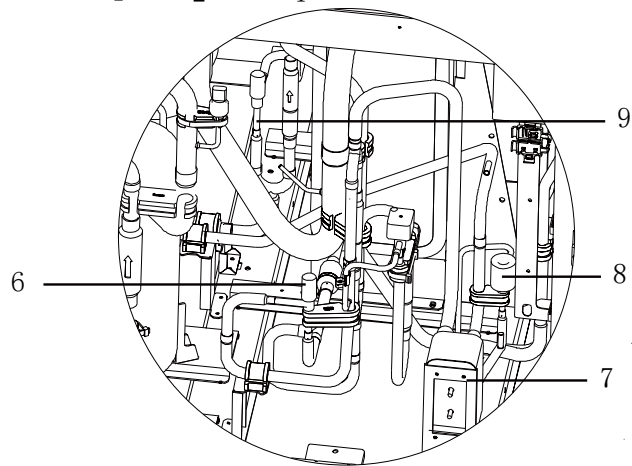
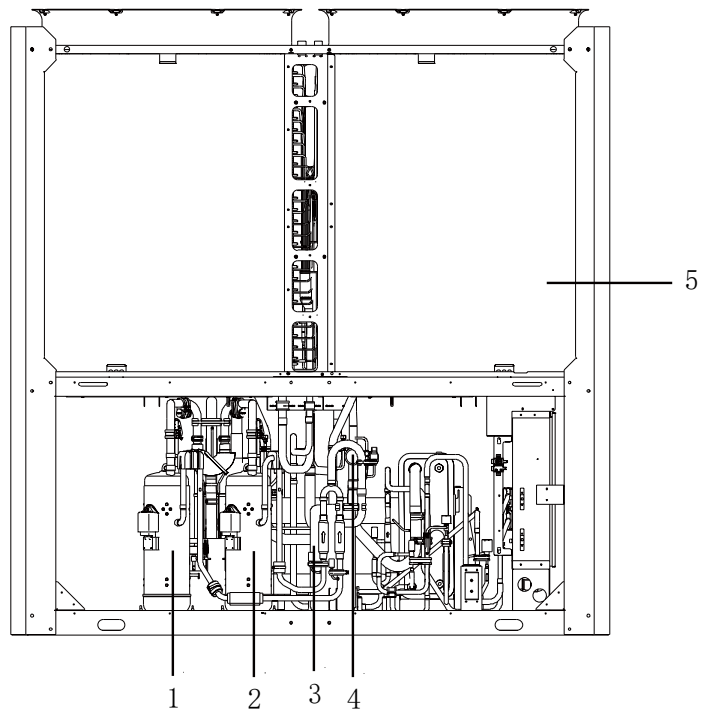
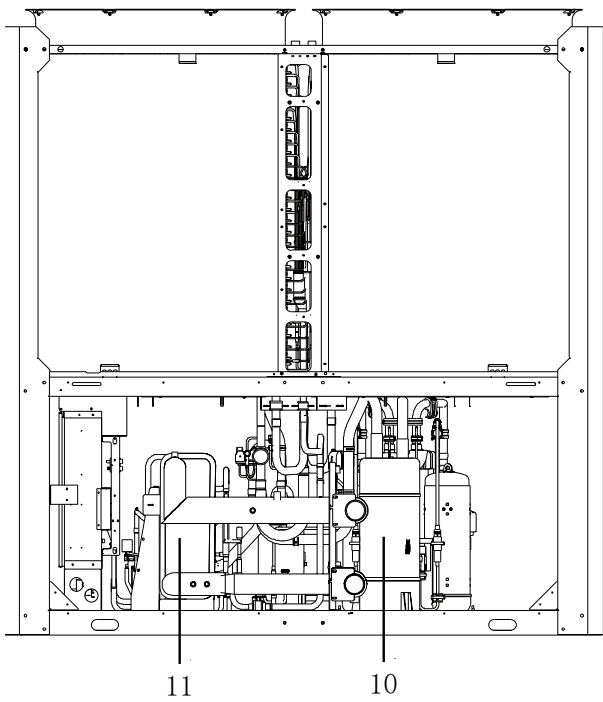

Component list of SCV-1400EB					
1	DC inverter compressor 1	5	Condenser	9	Electronic expansion valve
2	DC inverter compressor 2	6	Electronic expansion valve	10	Gas-liquid separator
3	Oil separator	7	Brazing plates heating exchanger	11	Plate heat exchanger
4	4-way valve	8	Electronic expansion valve		

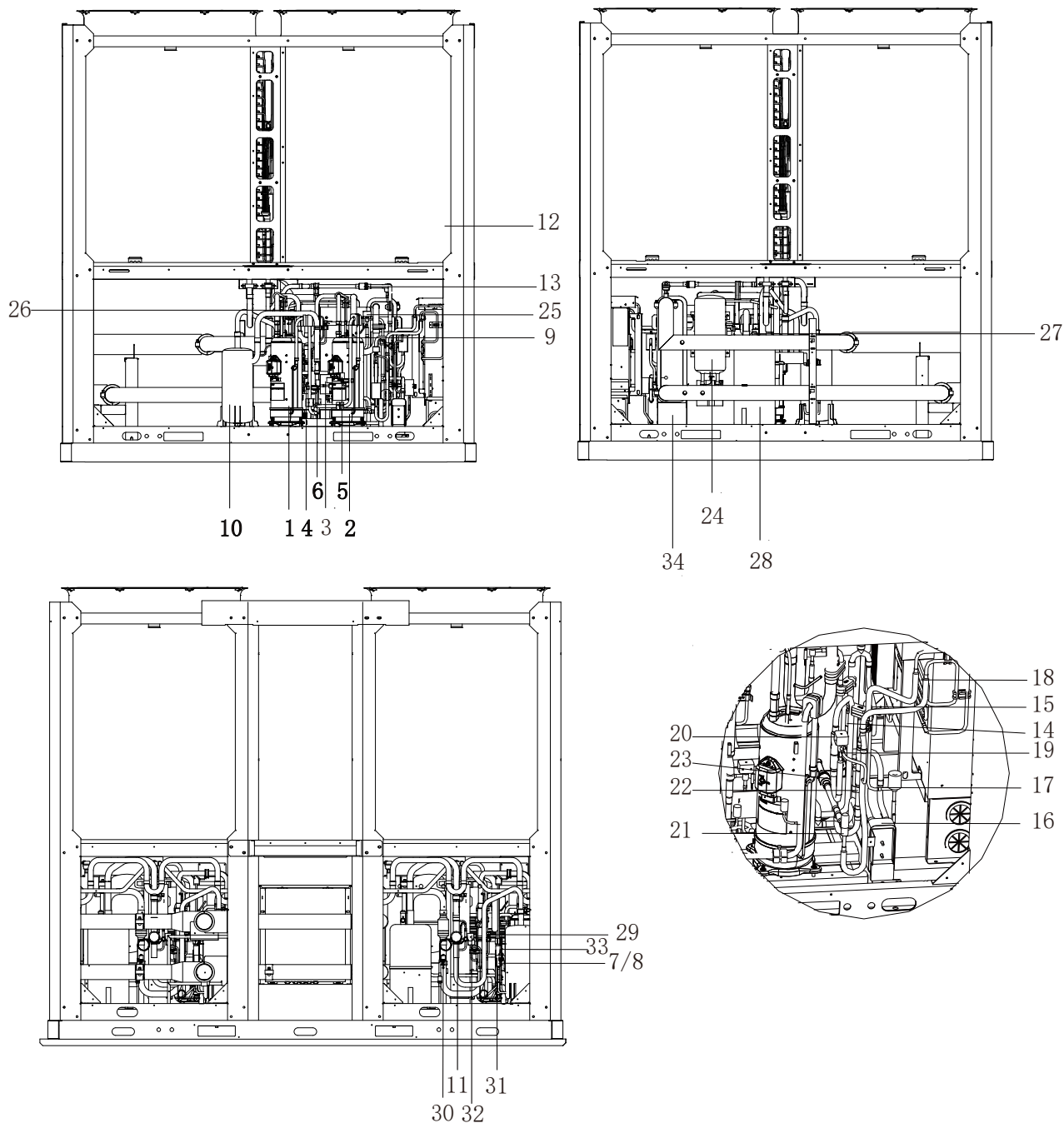

Component list of SCV-1800EB

Component list of SCV-1800EB					
1	DC inverter compressor 1	13	Filter	25	Single pass solenoid valve suit
2	DC inverter compressor 2	14	One-way valve	26	Pressure sensor
3	Enhanced vapor injection solenoid valve 1	15	Electronic expansion valve	27	Safety valve
4	Enhanced vapor injection solenoid valve 2	16	Brazing plates heating exchanger	28	Gas-liquid separator
5	High pressure switch	17	Electronic expansion valve	29	Meter connector
6	High pressure switch	18	Heat sink assembly	30	Low pressure switch
7	Filter	19	Single pass solenoid valve suit	31	Filter
8	Filter	20	One way valve	32	Single pass solenoid valve suit
9	Meter connector	21	Electronic expansion valve	33	Filter
10	4-way valve	22	One way valve	34	Plate heat exchanger
11	Oil seperator	23	Filter		
12	Condenser	24	Liquid storage tank		

2 Piping Diagrams

SCV-750EB

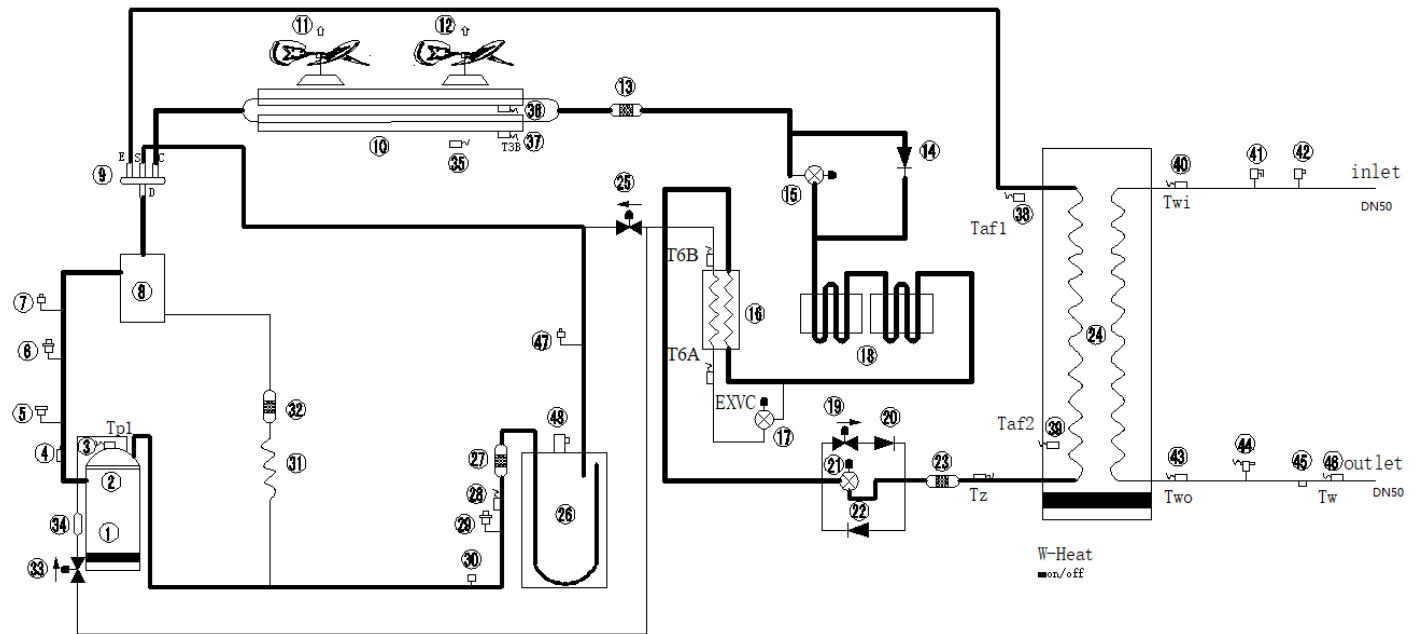

Legend

1	Crankcase heater	25	Solenoid valve
2	DC inverter compressor	26	Vapor-liquid separator
3	Discharge temperature sensor 1	27	Filter
4	Discharge temperature switch 1	28	Suction temperature sensor
5	High pressure switch	29	Low pressure sensor
6	High pressure sensor	30	Low pressure switch
7	Pin valve (Discharge side)	31	Capillary
8	Oil separator	32	Filter
9	4-way-valve	33	Enhanced vapor injection solenoid valve
10	Condenser	34	Muffler
11	DC fan 1	35	Ambient temperature sensor
12	DC fan 2	36	temperature sensor
13	Filter	37	temperature sensor
14	One-way valve	38	Antifreeze temperature sensor 1
15	Heating Electronic expansion valve	39	Antifreeze temperature sensor 2
16	Plate heat exchanger (Economizer)	40	Entering water temperature sensor
17	EVI Electronic expansion valve	41	Safety valve
18	Coil for cooling electronic control board	42	Air purge valve
19	Liquid side bypass solenoid valve	43	Leaving water temperature sensor
20	One-way valve	44	Water flow switch
21	Cooling Electronic expansion valve	45	Water drain
22	One-way valve	46	Total leaving water temperature sensor
23	Filter	47	Pin valve (Suction side)
24	Plate heat exchanger	48	Safety valve

Key components:

1. Compressor:

Maintains pressure differential between high and low pressure sides of the refrigerant system.

2. Fan:

Ventilates the air side heat exchanger.

3. Air side heat exchanger:

In the cooling mode, the heat of the refrigerant from the water side heat exchanger can be released into the air.

In the heating mode, the refrigerant can absorb the heat in the air and provide it to the water side heat exchanger.

4. Water side heat exchanger:

In cooling mode, the refrigerant can absorb heat from the water and reduce the temperature of the water.

In heating mode, the refrigerant can release heat into the water and increase the temperature of the water.

5. Four-way valve:

Controls refrigerant flow direction. Closed in cooling mode and open in heating mode. When closed, the air side heat exchanger functions as a condenser and water side heat exchanger functions as an evaporator; when open, the air side heat exchanger functions as an evaporator and water side heat exchanger function as a condenser.

6. Vapor-liquid separator:

Stores liquid refrigerant to protect the compressor from liquid hammering.

7. Oil separator:

Separates oil from gas refrigerant pumped out of the compressor and quickly returns it to the compressor. Separation efficiency is up to 99%.

8. Plate heat exchanger (Economizer):

In cooling mode, it can improve super-cooling degree and the super-cooled refrigerant can achieve better heat exchange in indoor side. In heating mode, the refrigerant comes from the plate heat exchanger going to the compressor can enhance the refrigerant enthalpy and improve the heating capacity in low ambient temperature. Refrigerant volume in plate heat exchanger is controlled according to temperature different between plate heat exchanger inlet and outlet.

9. Electronic expansion valve:

Controls refrigerant flow and reduces refrigerant pressure.

10. Solenoid valve SV5 (defrost):

Multiple functions for enhancing reliability.

11. Solenoid valve SV6 (by pass):

Increase refrigerant flow.

12. Solenoid valve SV8A, SV8B (injection):

Enhance enthalpy and capacity.

13. High and low pressure switches:

Regulate refrigerant system pressure. When the refrigerant system pressure rises above the upper limit or falls below the lower limit, the high or low pressure switches turn off, stopping the compressor.

14. Discharge temperature switch:

Protects the compressor from abnormally high temperatures and transient spikes in temperature.

15. High pressure sensor:

Measures compressor discharge side pressure of refrigerant.

16. Low pressure sensor:

Measures compressor suction side pressure of refrigerant.

17. Air purge valve:

Automatically removes air from the water circuit.

18. Safety valve (water side):

Prevents excessive water pressure by opening at 6bar and discharging water from the water circuit.

19. Water flow switch:

Detects water flow rate to protect the compressor and water pump in the event of insufficient water flow.

20. Safety valve (refrigerant side):

Prevents excessive refrigerant pressure by opening at 42bar and discharging refrigerant from the refrigerant system.

21. **Crankcase heater:**

Prevents refrigerant from mixing with compressor oil when the compressors are stopped.

22. **Water side heat exchanger electric heater:**

Protects the water side heat exchanger from ice formation.

23. **Water flow switch electric heater:**

Protects the water from ice formation.

24. **Pressure gauge joint (high and low pressure side):**

Charges or discharges refrigerant.

25. **Capillary:**

Normally return oil to the compressor.

26. **Wired Controller:**

Control and query the operation status of the unit.

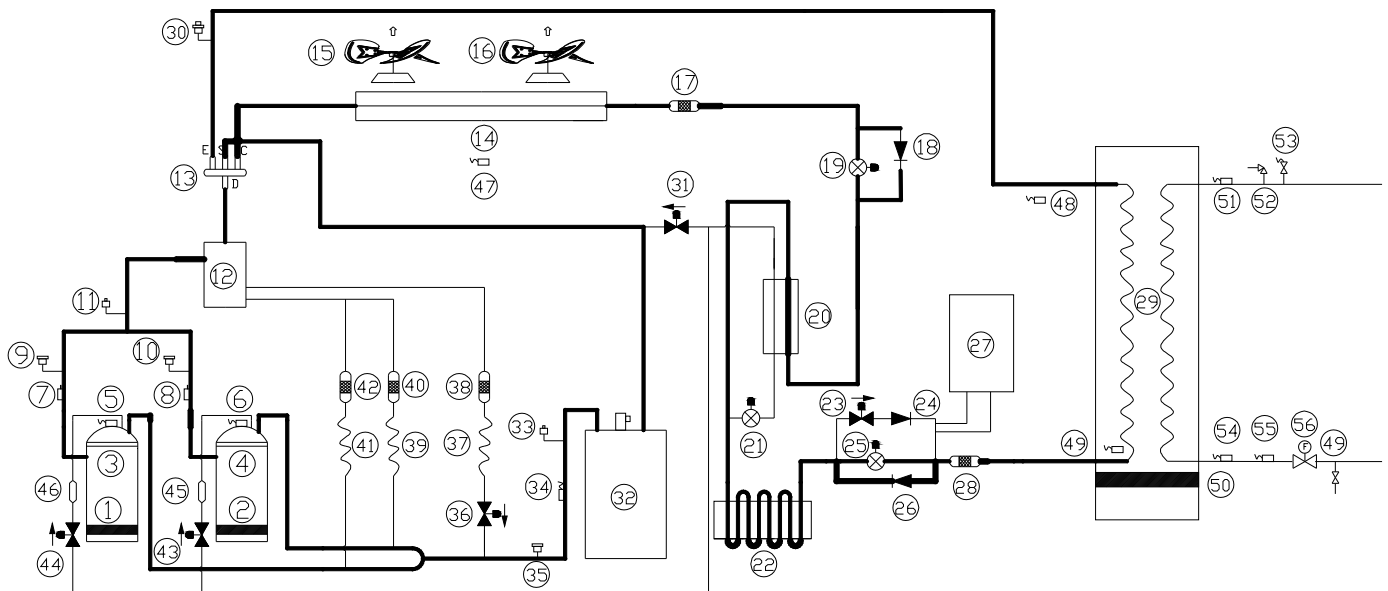

Legend

1	Crankcase heater 1	30	System pressure sensor
2	Crankcase heater 2	31	Solenoid valve
3	DC inverter compressor 1	32	Vapor-liquid separator
4	DC inverter compressor 2	33	Pin valve (Suction side)
5	Discharge temperature sensor 1	34	Suction temperature sensor
6	Discharge temperature sensor 2	35	Low pressure switch
7	Discharge temperature switch 1	36	Fast oil return solenoid valve
8	Discharge temperature switch 2	37	Capillary
9	High pressure switch 1	38	Filter
10	High pressure switch 2	39	Capillary
11	Pin valve (Discharge side)	40	Filter
12	Oil separator	41	Capillary
13	4-way-valve	42	Filter
14	Condenser	43	Enhanced vapor injection solenoid valve 1
15	DC fan 1	44	Enhanced vapor injection solenoid valve 2
16	DC fan 2	45	Muffler 1
17	Filter	46	Muffler 2
18	One-way valve	47	Ambient temperature sensor
19	Heating Electronic expansion valve	48	Antifreeze temperature sensor 1
20	Plate heat exchanger (Economizer)	49	Antifreeze temperature sensor 2
21	EVI electronic expansion valve	50	Water side heat exchanger electric heater
22	Coil for cooling electronic control board	51	Entering water temperature sensor
23	Liquid side bypass solenoid valve	52	Safety valve
24	One-way valve	53	Air purge valve
25	Cooling Electronic expansion valve	54	Leaving water temperature sensor
26	One-way valve	55	Total leaving water temperature sensor
27	High pressure tank	56	Water flow switch
28	Filter	57	Manual water drain valve
29	Plate heat exchanger		

Key components:**1. Compressor**

Maintains pressure differential between high and low pressure sides of the refrigerant system.

2. Fan:

Ventilates the air side heat exchanger.

3. Oil separator:

Separates oil from gas refrigerant pumped out of the compressor and quickly returns it to the compressor. Separation efficiency is up to 99%.

4. Vapor-liquid separator:

Stores liquid refrigerant to protect the compressor from liquid hammering.

5. Electronic expansion valve:

Controls refrigerant flow and reduces refrigerant pressure.

6. Four-way valve:

Controls refrigerant flow direction. Closed in cooling mode and open in heating mode. When closed, the air side heat exchanger functions as a condenser and water side heat exchanger functions as an evaporator; when open, the air side heat exchanger functions as an evaporator and water side heat exchanger function as a condenser.

7. High and low pressure switches:

Regulate refrigerant system pressure. When the refrigerant system pressure rises above the upper limit or falls below the lower limit, the high or low pressure switches turn off, stopping the compressor.

8. Discharge temperature switch:

Protects the compressor from abnormally high temperatures and transient spikes in temperature.

9. Air purge valve:

Automatically removes air from the water circuit.

10. Safety valve:

Prevents excessive water pressure by opening at 6bar and discharging water from the water circuit.

11. Water flow switch:

Detects water flow rate to protect the compressor and water pump in the event of insufficient water flow.

12. Pressure sensor:

Measures refrigerant system pressure.

13. Crankcase heater:

Prevents refrigerant from mixing with compressor oil when the compressors are stopped.

14. Water side heat exchanger electric heater:

Protects the water side heat exchanger from ice formation.

15. Water flow switch electric heater:

Protects the water from ice formation.

16. Plate heat exchanger(Economizer):

In cooling mode, it can improve super-cooling degree and the super-cooled refrigerant can achieve better heat exchange in indoor side. In heating mode, the refrigerant comes from the plate heat exchanger going to the compressor can enhance the refrigerant enthalpy and improve the heating capacity in low ambient temperature. Refrigerant volume in plate heat exchanger is controlled according to temperature different between plate heat exchanger inlet and outlet.

17. Pressure gauge joint (high and low pressure side):

Charges or discharges refrigerant.

18. Capillary:

Normally return oil to the compressor.

19. Solenoid valve SV4(oil balance):

Quickly return oil to the compressor.

20. Solenoid valve SV5(defrost):

Multiple functions for enhancing reliability.

21. Solenoid valve SV6(by pass):

Increase refrigerant flow.

22. Solenoid valve SV8A, SV8B(injection):

Enhance enthalpy and capacity.

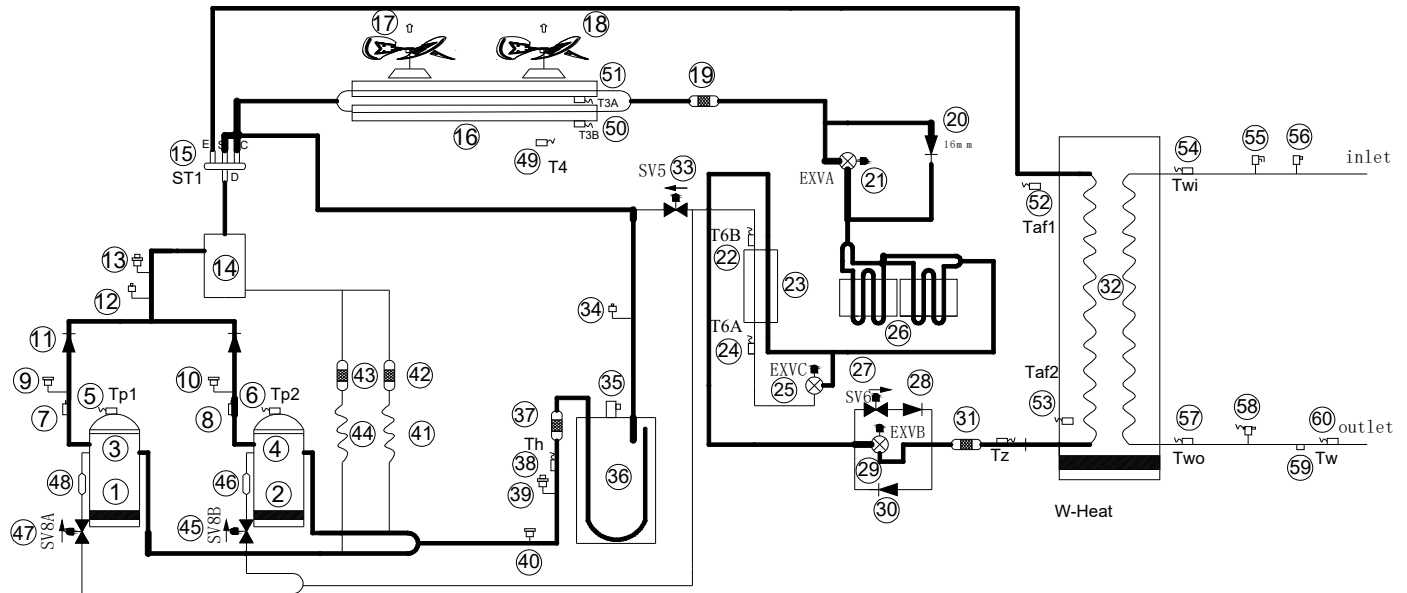

Legend

1	Crankcase heater 1	31	Filter
2	Crankcase heater 2	32	Plate heat exchanger
3	DC inverter compressor 1	33	Solenoid valve
4	DC inverter compressor 2	34	Pin valve (Suction side)
5	Discharge temperature sensor 1	35	Safety valve
6	Discharge temperature sensor 2	36	Vapor-liquid separator
7	Discharge temperature switch 1	37	Filter
8	Discharge temperature switch 2	38	Suction temperature sensor
9	High pressure switch 1	39	Low pressure sensor
10	High pressure switch 2	40	Low pressure switch
11	One-way valve	41	Capillary
12	Pin valve	42	Filter
13	High pressure sensor	43	Capillary
14	Oil separator	44	Filter
15	4-way-valve	45	Enhanced vapor injection solenoid valve 1
16	Condenser	46	Muffler 1
17	DC fan 1	47	Enhanced vapor injection solenoid valve 2
18	DC fan 2	48	Muffler 2
19	Filter	49	Ambient temperature sensor
20	One-way valve	50	temperature sensor
21	Electronic expansion valve	51	temperature sensor
22	temperature sensor	52	Antifreeze temperature sensor 1
23	Plate heat exchanger (Economizer)	53	Antifreeze temperature sensor 2
24	EVI plate heat exchanger refrigerant temperature sensor	54	Entering water temperature sensor
25	Electronic expansion valve	55	Safety valve
26	Coil for cooling electronic control board	56	Air purge valve
27	Liquid side bypass solenoid valve	57	Leaving water temperature sensor
28	One-way valve	58	Water flow switch
29	Electronic expansion valve	59	Water drain
30	One-way valve	60	Total leaving water temperature sensor

Key components:

1. Compressor

Maintains pressure differential between high and low pressure sides of the refrigerant system.

2. Fan:

Ventilates the air side heat exchanger.

3. Air side heat exchanger:

In the cooling mode, the heat of the refrigerant from the water side heat exchanger can be released into the air.

In the heating mode, the refrigerant can absorb the heat in the air and provide it to the water side heat exchanger.

4. Water side heat exchanger:

In cooling mode, the refrigerant can absorb heat from the water and reduce the temperature of the water.

In heating mode, the refrigerant can release heat into the water and increase the temperature of the water.

5. Four-way valve:

Controls refrigerant flow direction. Closed in cooling mode and open in heating mode. When closed, the air side heat exchanger functions as a condenser and water side heat exchanger functions as an evaporator; when open, the air side heat exchanger functions as an evaporator and water side heat exchanger function as a condenser.

6. Vapor-liquid separator:

Stores liquid refrigerant to protect the compressor from liquid hammering.

7. Oil separator:

Separates oil from gas refrigerant pumped out of the compressor and quickly returns it to the compressor. Separation efficiency is up to 99%.

8. Plate heat exchanger (Economizer):

In cooling mode, it can improve super-cooling degree and the super-cooled refrigerant can achieve better heat exchange in indoor side. In heating mode, the refrigerant comes from the plate heat exchanger going to the compressor can enhance the refrigerant enthalpy and improve the heating capacity in low ambient temperature. Refrigerant volume in plate heat exchanger is controlled according to temperature different between plate heat exchanger inlet and outlet.

9. Electronic expansion valve:

Controls refrigerant flow and reduces refrigerant pressure.

10. Solenoid valve SV5 (defrost):

Multiple functions for enhancing reliability.

11. Solenoid valve SV6 (by pass):

Increase refrigerant flow.

12. Solenoid valve SV8A, SV8B (injection):

Enhance enthalpy and capacity.

13. High and low pressure switches:

Regulate refrigerant system pressure. When the refrigerant system pressure rises above the upper limit or falls below the lower limit, the high or low pressure switches turn off, stopping the compressor.

14. Discharge temperature switch:

Protects the compressor from abnormally high temperatures and transient spikes in temperature.

15. High pressure sensor:

Measures compressor discharge side pressure of refrigerant.

16. Low pressure sensor:

Measures compressor suction side pressure of refrigerant.

17. Air purge valve:

Automatically removes air from the water circuit.

18. Safety valve (water side):

Prevents excessive water pressure by opening at 6bar and discharging water from the water circuit.

19. Water flow switch:

Detects water flow rate to protect the compressor and water pump in the event of insufficient water flow.

20. Safety valve (refrigerant side):

Prevents excessive refrigerant pressure by opening at 42bar and discharging refrigerant from the refrigerant system.

21. Crankcase heater:

Prevents refrigerant from mixing with compressor oil when the compressors are stopped.

22. Water side heat exchanger electric heater:

Protects the water side heat exchanger from ice formation.

23. Water flow switch electric heater:

Protects the water from ice formation.

24. Pressure gauge joint (high and low pressure side):

Charges or discharges refrigerant.

25. Capillary:

Normally return oil to the compressor.

26. Wired Controller:

Control and query the operation status of the unit.

SCV-1800EB

The piping diagrams is the same as SCV-900EB. SCV-1800EB system consists of two independent SCV-900EB systems.

3 Refrigerant Flow Diagrams

SCV-750EB

- High temperature, high press gas
- High temperature, high press liquid
- Low temperature, low press

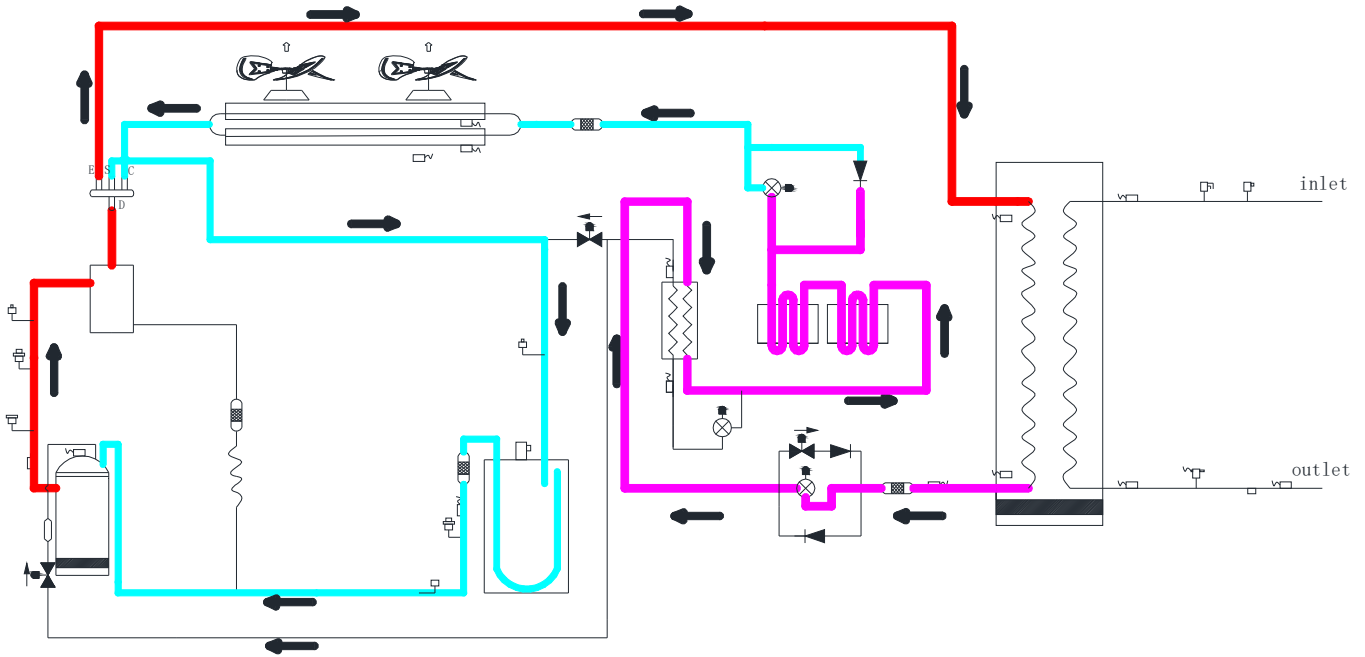

Heating operation

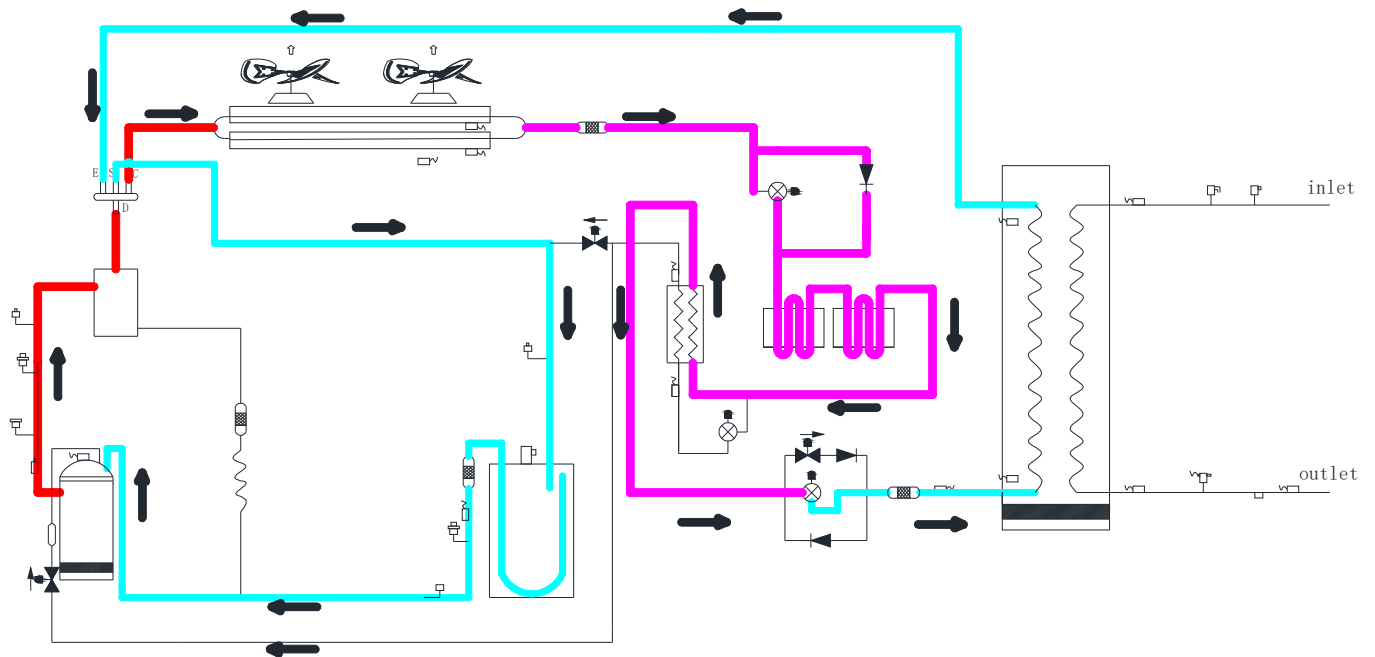

Cooling and defrosting operation



SCV-900EB

-  High temperature, high press gas
-  High temperature, high press liquid
-  Low temperature, low press

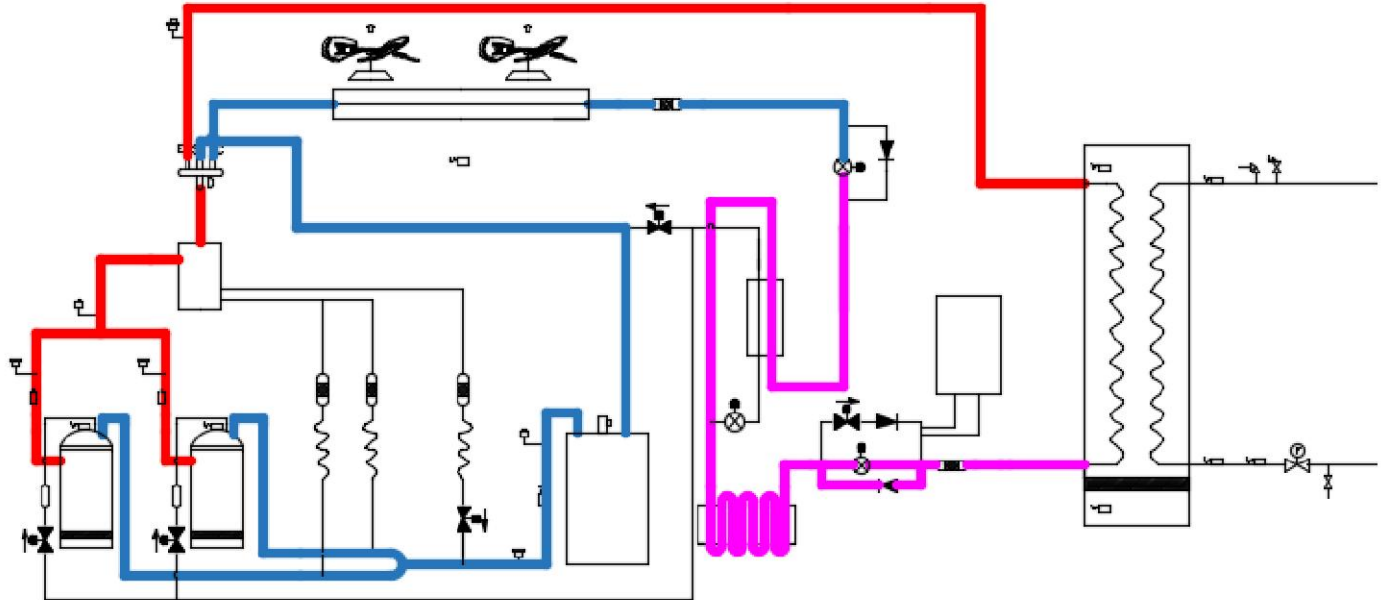

Heating operation

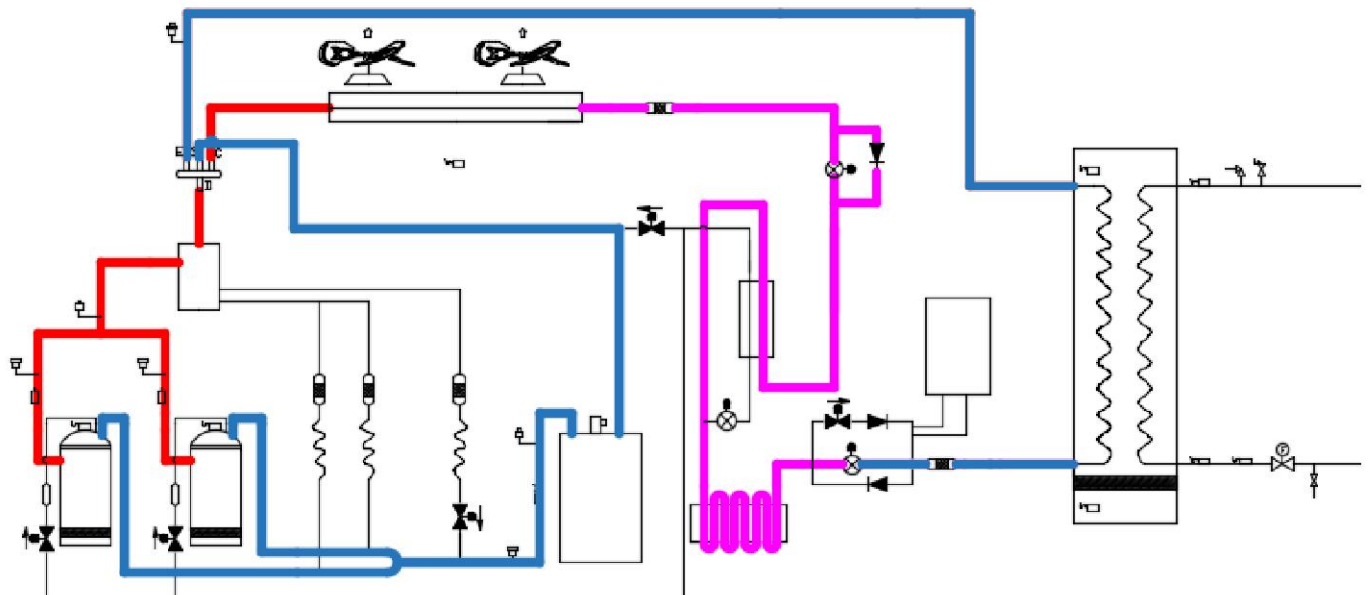

Cooling and defrosting operation



SCV-1400EB

-  High temperature, high press gas
-  High temperature, high press liquid
-  Low temperature, low press

Heating operation

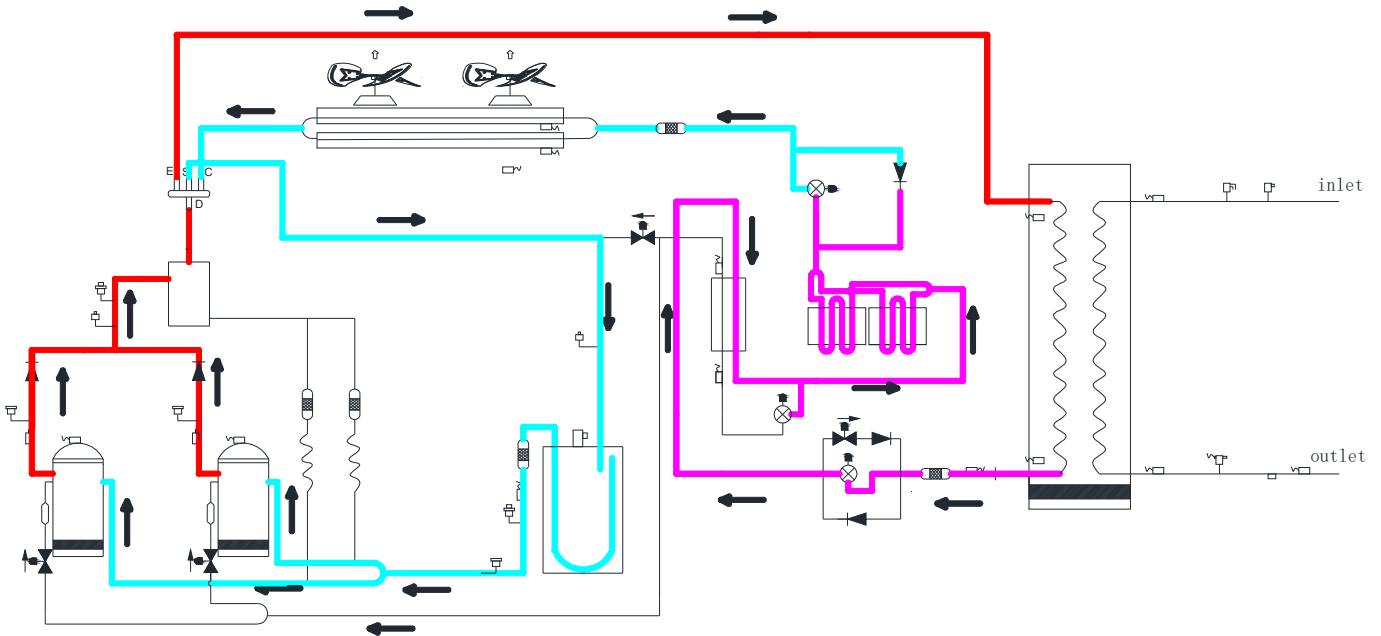

Cooling and defrosting operation

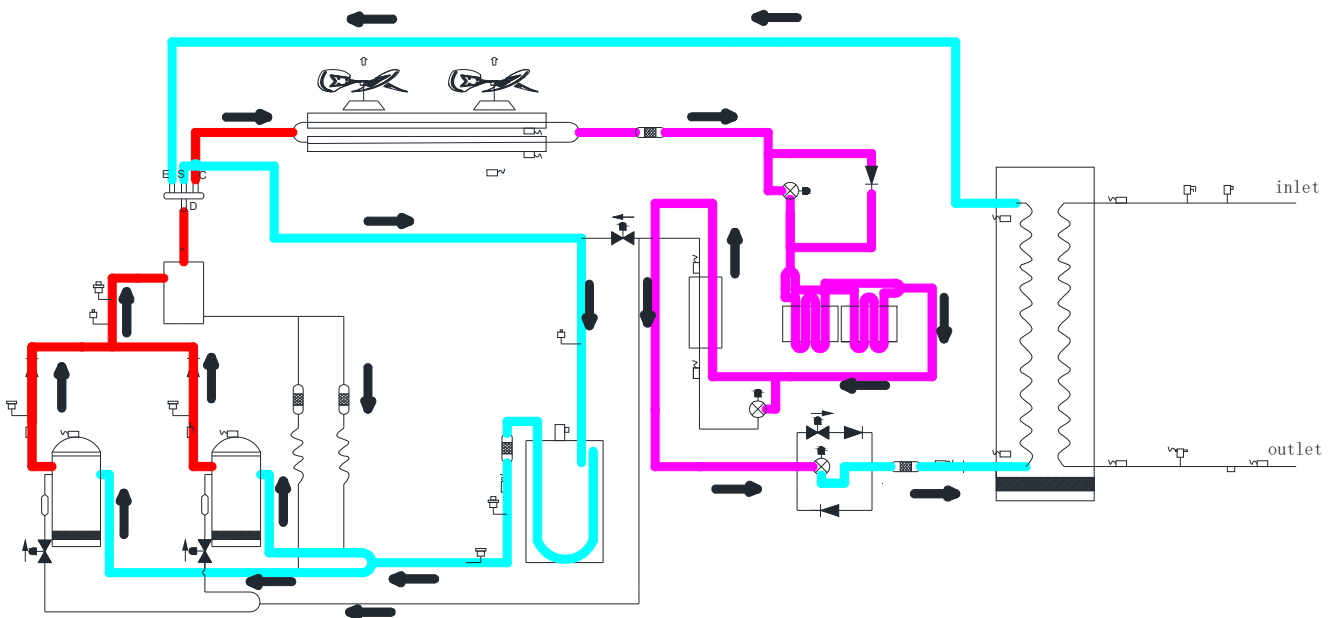

SCV-1800EB

The refrigerant flow diagrams is same as SCV-900EB. SCV-1800EB system consists of two independent SCV-900EB systems.

Part 3

Control

1 General Control Scheme Flowchart	26
2 Stop Operation	27
3 Standby Control	27
4 Startup Control	28
5 Normal Operation Control	31
6 Protection Control	37
7 Special Control.....	41

1 General Control Scheme Flowchart

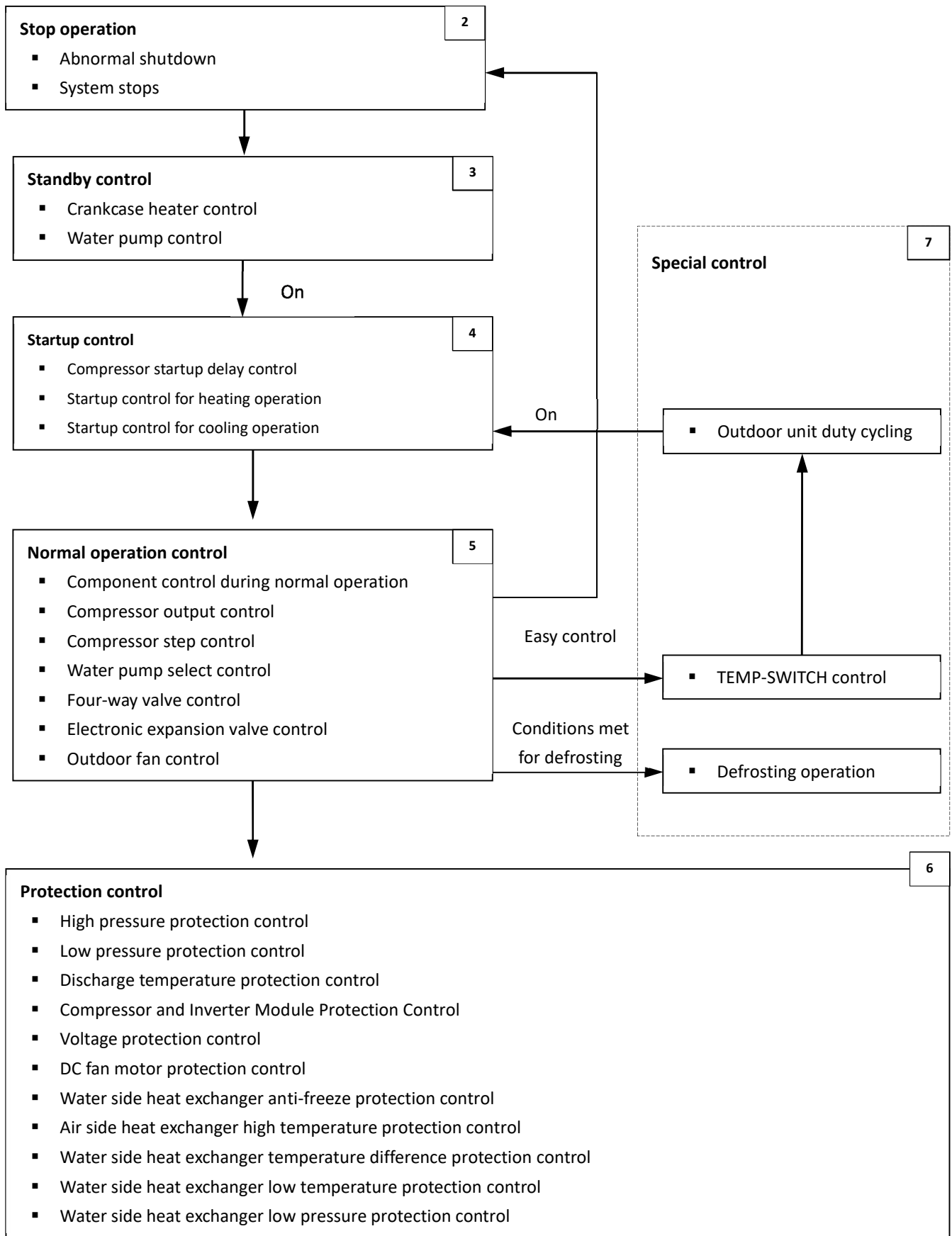

Note:

- Numbers in the top right-hand corners of boxes indicate the relevant section of text on the following pages.

2 Stop Operation

The stop operation occurs for one of the following reasons:

1. Abnormal shutdown: in order to protect the compressors, if an abnormal state occurs the system makes a stop with thermo off operation and an error code is displayed on the outdoor unit's PCB digital displays and on the user interface.
2. The system stops when the set temperature has been reached.

In order to prevent the compressor from starting and stopping frequently and to balance the pressure in the refrigeration system, forcibly stop the compressor for 7 minutes before starting. (Except for special controls such as defrosting).

3 Standby Control

3.1 Crankcase Heater Control

The crankcase heater is used to prevent refrigerant from mixing with compressor oil when the compressors are stopped. The crankcase heater is controlled according to the outdoor ambient temperature and discharge temperature. When the outdoor ambient temperature is above 40°C, the crankcase heater is off; when the outdoor ambient temperature is below 35°C, the crankcase heater is controlled according to discharge temperature.

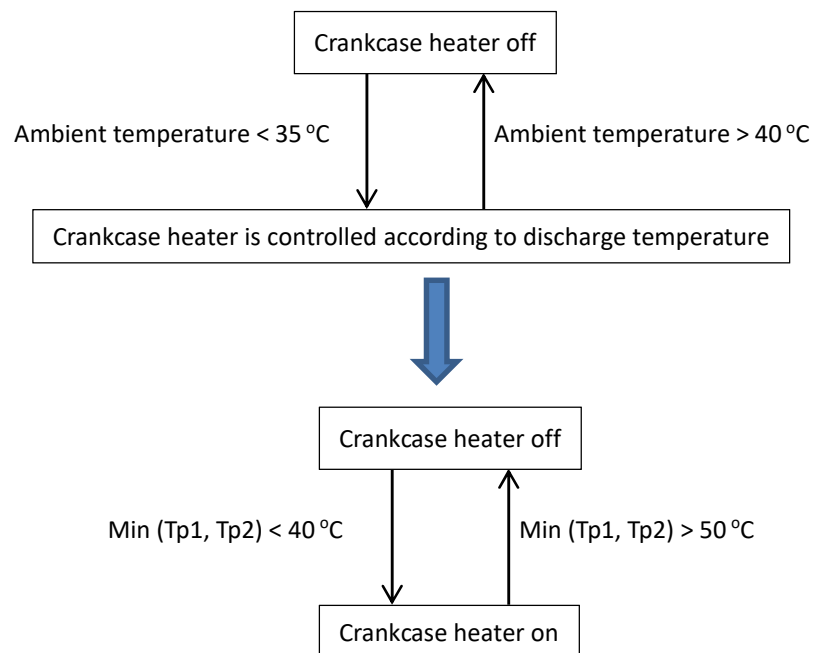

Notes:

1. Tp1: discharge temperature sensor 1;
2. Tp2: discharge temperature sensor 2.

3.2 Water Pump Control

When the outdoor unit is in standby, the circulator pump run continuously.

4 Startup Control

4.1 Compressor Startup Delay Control

In initial startup control and restart control (except in defrosting operation), compressor startup is delayed such that a minimum 7 minutes has elapsed since the compressor stopped, in order to prevent frequency compressor on/off and to equalize the pressure within the refrigerant system.

4.2 Startup Control for Heating Operation

For SCV-900EB:

Component	Wiring diagram label	90kW	Control functions and states
DC fan motor A	Fan A	●	Startup after 4-way valve changes refrigerant flow direction. Controlled according to discharge pressure.
DC fan motor B	Fan B	●	
Electronic expansion valve A	EXVA	●	Step from 0 to 480. Controlled according to discharge temperature superheat.
Electronic expansion valve B	EXVB	●	Step 480
Electronic expansion valve C	EXVC	●	Step from 0 to 480. Controlled according to temperature difference between economizer plate heat exchanger inlet and outlet.
Four-way valve	ST1	●	On
Solenoid valve (oil balance)	SV4	●	Closed for 200s, open for 600s, then closed.
Solenoid valve (defrost)	SV5	●	Closed
Solenoid valve (by pass)	SV6	●	Closed
Solenoid valve (injection)	SV8A/B	●	Open
Water flow switch	Water-SW	●	After water pump (field supplied) is turned on for 2min, if water flow switch is open, water pump stops and water flow error code appears. The compressor can be started after the water flow is normal.
Electric auxiliary heater (pipe)	-	●	Controlled according to ambient temperature and total water outlet temperature.
Crank case heater	CCH	●	Controlled according to ambient temperature and discharge temperature.

For SCV-750EB and SCV-1400EB:

Component	Wiring diagram label	75kW	140kW	Control functions and states
Water pump	PUMP	●	●	Non-standard component: After the pump is turned on for 2 minutes, detect the water flow switch continuously. The compressor can be started only after the water flow is normal.
Inverter compressor 1	BP1	●	●	Control the outlet water temperature. The operating increased and decreased frequency is 1Hz/s, and is executed according to the starting platform.
Inverter compressor 2	BP2	●	●	
Inverter fan1	FAN1	●	●	Startup after 4-way valve changes refrigerant flow direction. Controlled according to ambient temperature, discharge pressure and compressor frequency.
Inverter fan 2	FAN2	●	●	
Electronic expansion valve	EXV-A	●	●	Step from 0 to 480. Controlled according to discharge temperature superheat.
Electronic expansion valve	EXV-B	●	●	Step 480P
Electronic expansion valve	EXV-C	●	●	Enhanced vapor injection EXV, Step from 0 to 480. Controlled according to temperature difference between economizer plate heat exchanger inlet and outlet.

Four-way valve	ST1	●	●	Open
Solenoid valve (defrost)	SV5	●	●	Closed
Solenoid valve (by pass)	SV6	●	●	Closed
Solenoid valve (injection)	SV8A/B	●	●	Open
Water flow switch	Water-SW	●	●	After water pump (field supplied) is turned on for 2min, if water flow switch is open, water pump stops and water flow error code appears. The compressor can be started after the water flow is normal.
Electric auxiliary heater (pipe)	-	●	●	Controlled according to ambient temperature and total water outlet temperature.
Crank case heater	CCH	●	●	Controlled according to ambient temperature and discharge temperature.

For SCV-1800EB:

Component	Wiring diagram label	180kW	Control functions and states
Inverter compressor	BP1/2	●	Compressor startup program selected according to ambient temperature.
DC fan motor	FAN	●	Fan run at maximum speed ¹ .
Electronic expansion valve	EXV	●	Position (steps) from 0 (fully closed) to 480 (fully open), controlled according to outdoor ambient temperature, discharge temperature, suction superheat, compressor speed and refrigerant system pressure.
Four-way valve	ST1	●	On

Notes: 1. Refer to Table 3-4.1 in Part 3, 5.8 "Outdoor Fan Control".

4.3 Startup Control for Cooling Operation

For SCV-900EB:

Component	Wiring diagram label	90kW	Control functions and states
DC fan motor A	Fan A	●	According to ambient temperature, compressor frequency and air side heat exchanger refrigerant total outlet temperature.
DC fan motor B	Fan B	●	
Electronic expansion valve A	EXVA	●	Step 480
Electronic expansion valve B	EXVB	●	Step from 0 to 480. Controlled according to suction temperature superheat.
Electronic expansion valve C	EXVC	●	Step from 0 to 480. Controlled according to temperature difference between economizer plate heat exchanger inlet and outlet.
Four-way valve	ST1	●	Closed
Solenoid valve (oil balance)	SV4	●	Closed for 200s, open for 600s, then closed.
Solenoid valve (defrost)	SV5	●	Closed
Solenoid valve (by pass)	SV6	●	Open for 600s then closed.
Solenoid valve (injection)	SV8A/B	●	Open
Water side heat exchanger heater	-	●	According to water side heat exchanger anti-freezing temperature.
Water flow switch	Water-SW	●	After water pump (field supplied) is turned on for 2min, if water flow switch is open, water pump stops and water flow error code appears. The compressor can be started after the water flow is normal.
Water flow switch heater		●	Controlled according to ambient temperature, water inlet temperature and water outlet temperature.
Crank case heater	CCH		Controlled according to ambient temperature and discharge temperature.

For SCV-750EB and SCV-1400EB:

Component	Wiring diagram label	75kW	140kW	Control functions and states
Water pump	PUMP	●	●	Non-standard component: After the pump is turned on for 2 minutes, detect the water flow switch continuously. The compressor can be started only after the water flow is normal.
Inverter compressor 1	BP1	●	●	Control the outlet water temperature. The operating increased and decreased frequency is 1Hz/s, and is executed according to the starting platform.
Inverter compressor 2	BP2	●	●	
Inverter fan1	FAN1	●	●	Control According to the exhaust pressure of the outdoor unit, the initial target windshield is operated for the first 60s, and then correct every 20-60s.
Inverter fan 2	FAN2	●	●	
Electronic expansion valve	EXV-A	●	●	Step from 0 to 480. Controlled according to discharge temperature superheat.
Electronic expansion valve	EXV-B	●	●	Step 480P
Electronic expansion valve	EXV-C	●	●	Step from 0 to 480. Controlled according to temperature difference between economizer plate heat exchanger inlet and outlet.
Four-way valve	ST1	●	●	Open
Solenoid valve (defrost)	SV5	●	●	Closed
Solenoid valve (by pass)	SV6	●	●	Open for 600s, then closed.
Solenoid valve (injection)	SV8A/B	●	●	Open
Water flow switch	Water-SW	●	●	After water pump (field supplied) is turned on for 2min, if water flow switch is open, water pump stops and water flow error code appears. The compressor can be started after the water flow is normal.
Water flow switch heater		●	●	Controlled according to ambient temperature, water inlet temperature and water outlet temperature.
Crank case heater	CCH		●	Controlled according to ambient temperature and discharge temperature.

For SCV-1800EB:

Component	Wiring diagram label	180kW	Control functions and states
Inverter compressor	BP1/2	●	Compressor startup program selected according to ambient temperature ¹ .
DC fan motor	FAN	●	Fan run at maximum speed ² .
Electronic expansion valve	EXV	●	Position (steps) from 0 (fully closed) to 480 (fully open), controlled according to outdoor ambient temperature, discharge temperature, suction superheat, compressor speed and refrigerant system pressure.
Four-way valve	ST1	●	Off

5 Normal Operation Control

5.1 Component Control during heating mode

For SCV-900EB:

Component	Wiring diagram label	90kW	Control functions and states
Inverter compressor A	BP1	●	Controlled according to load requirement.
Inverter compressor B	BP2	●	
DC fan motor A	Fan A	●	Startup after 4-way valve changes refrigerant flow direction.
DC fan motor B	Fan B	●	Controlled according to discharge pressure.
Electronic expansion valve A	EXVA	●	Step from 0 to 480. Controlled according to discharge temperature superheat.
Electronic expansion valve B	EXVB	●	Step 480
Electronic expansion valve C	EXVC	●	Step from 0 to 480. Controlled according to temperature difference between economizer plate heat exchanger inlet and outlet.
Four-way valve	ST1	●	On
Solenoid valve (oil balance)	SV4	●	Open for 3min after every 17min.
Solenoid valve (defrost)	SV5	●	Closed
Solenoid valve (by pass)	SV6	●	Closed
Solenoid valve (injection)	SV8A/B	●	Open
Water flow switch	Water-SW	●	After water pump (field supplied) is turned on for 2min, if water flow switch is open, water pump stops and water flow error code appears. The compressor can be started after the water flow is normal.
Electric auxiliary heater (pipe)	-	●	Controlled according to ambient temperature and total water outlet temperature.
Crank case heater	c	●	Controlled according to ambient temperature and discharge temperature.

For SCV-750EB and SCV-1400EB:

Component	Wiring diagram label	75kW	140kW	Control functions and states
Water pump	PUMP	●	●	Open
Inverter compressor 1	BP1	●	●	Control the outlet water temperature. The operating increased and decreased frequency is 1Hz/s.
Inverter compressor 2	BP2	●	●	
Inverter fan1	FAN1	●	●	Startup after 4-way valve changes refrigerant flow direction. Controlled according to ambient temperature, discharge pressure and compressor frequency.
Inverter fan 2	FAN2	●	●	
Electronic expansion valve	EXV-A	●	●	Step from 0 to 480. Controlled according to discharge temperature superheat.
Electronic expansion valve	EXV-B	●	●	Step 480.
Electronic expansion valve	EXV-C	●	●	Enhanced vapor injection EXV, Step from 0 to 480. Controlled according to temperature difference between economizer plate heat exchanger inlet and outlet.
Four-way valve	ST1	●	●	Open
Solenoid valve (defrost)	SV5	●	●	Open during defrost and close at other times.
Solenoid valve (by pass)	SV6	●	●	Closed
Solenoid valve (injection)	SV8A/B	●	●	Open

For SCV-1800EB:

Component	Wiring diagram label	180kW	Control functions and states
Inverter compressor	BP1/2	●	Controlled according to load requirement from hydronic system.
DC fan motor	FAN	●	Controlled according to outdoor heat exchanger pipe temperature.
Electronic expansion valve	EXV	●	Position (steps) from 0 (fully closed) to 480 (fully open), controlled according to outdoor ambient temperature, discharge temperature, suction superheat, compressor speed and refrigerant system pressure.
Four-way valve	ST1	●	On

5.2 Component control during cooling mode

For SCV-900EB:

Component	Wiring diagram label	90kW	Control functions and states
Inverter compressor A	BP1	●	Controlled according to load requirement.
Inverter compressor B	BP2	●	
DC fan motor A	Fan A	●	Controlled according to ambient temperature and discharge pressure and air side heat exchanger refrigerant temperature.
DC fan motor B	Fan B	●	
Electronic expansion valve A	EXVA	●	Step 480
Electronic expansion valve B	EXVB	●	Step from 0 to 480. Controlled according to suction temperature superheat.
Electronic expansion valve C	EXVC	●	Step from 0 to 480. Controlled according to temperature difference between economizer plate heat exchanger inlet and outlet.
Four-way valve	ST1	●	Closed
Solenoid valve (oil balance)	SV4	●	Open for 3min after every 17min.
Solenoid valve (defrost)	SV5	●	Closed
Solenoid valve (by pass)	SV6	●	Closed
Solenoid valve (injection)	SV8A/B	●	Open
Water side heat exchanger heater	-	●	According to water side heat exchanger anti-freezing temperature.
Water flow switch	Water-SW	●	After water pump (field supplied) is turned on for 2min, if water flow switch is open, water pump stops and water flow error code appears. The compressor can be started after the water flow is normal.
Water flow switch heater	-	●	Controlled according to ambient temperature, water inlet temperature and water outlet temperature.
Crank case heater	CCH	●	Controlled according to ambient temperature and discharge temperature.

For SCV-750EB and SCV-1400EB:

Component	Wiring diagram label	75kW	140kW	Control functions and states
Inverter compressor 1	BP1	●	●	Control the outlet water temperature. The operating increased and decreased frequency is 1Hz/s.
Inverter compressor 2	BP2	●	●	
Inverter fan1	FAN1	●	●	Control according to the exhaust pressure of the outdoor unit. Correct every 20-60s, and adjust in 0-32 gears.
Inverter fan 2	FAN2	●	●	
Electronic expansion valve	EXV-A	●	●	Step 480.

Electronic expansion valve	EXV-B	●	●	Step from 0 to 480. Controlled according to discharge temperature superheat.
Electronic expansion valve	EXV-C	●	●	Enhanced vapor injection EXV, Step from 0 to 480. Controlled according to temperature difference between economizer plate heat exchanger inlet and outlet.
Four-way valve	ST1	●	●	Closed
Solenoid valve (defrost)	SV5	●	●	Closed
Solenoid valve (by pass)	SV6	●	●	Closed
Solenoid valve (injection)	SV8A/B	●	●	Open
Water side heat exchanger heater	-	●	●	According to water side heat exchanger anti-freezing temperature
Water flow switch	Water-SW	●	●	After water pump (field supplied) is turned on for 2min, if water flow switch is open, water pump stops and water flow error code appears. The compressor can be started after the water flow is normal.
Water flow switch heater	-	●	●	Controlled according to ambient temperature, water inlet temperature and water outlet temperature
Crank case heater	CCH	●	●	Controlled according to ambient temperature and discharge temperature

For SCV-1800EB:

Component	Wiring diagram label	180kW	Control functions and states
Inverter compressor	BP1/2	●	Controlled according to load requirement from hydronic system.
DC fan motor	FAN	●	Controlled according to outdoor heat exchanger pipe temperature.
Electronic expansion valve	EXV	●	Position (steps) from 0 (fully closed) to 480 (fully open), controlled according to outdoor ambient temperature, discharge temperature, suction superheat, compressor speed and refrigerant system pressure.
Four-way valve	ST1	●	Off

5.3 Compressor Output Control

The compressor rotation speed is controlled according to the load requirement. Before compressor startup, the outdoor unit determines the compressor target speed according to outdoor ambient temperature, discharge temperature and then runs the appropriate compressor startup program. Once the startup program is complete, the compressor runs at the target rotation speed.

The compressor speed is controlled according to two parts in normal operation:

In cooling mode: In a single system, the compressor speed is controlled according to the water outlet temperature and water outlet setting temperature. In a combination system, the compressor of master unit is controlled according total water outlet temperature and water outlet setting temperature, the compressor of the slave unit is controlled according to water inlet and water outlet temperature. Both in a single system and combination system, the compressor speed is limited by the inverter module temperature (calculated value), ambient temperature, discharge temperature, discharge pressure and air side heat exchanger refrigerant total outlet temperature.

5.4 Compressor Step Control

The running speed of six-pole compressors in rotations per second (rps) is one third of the frequency (in Hz) of the electrical input to the compressor motor. The frequency of the electrical input to the compressor motors can be altered at a rate of 1Hz in two seconds.

5.5 Four-way Valve Control

The four-way valve is used to change the direction of refrigerant flow through the water side heat exchanger in order to switch between cooling and heating operations. During heating operation, the four-way valve is on; during cooling and defrosting operation, the four-way valve is off.

5.6 Electronic Expansion Valve Control

- Power-on self-test:
When the power is first turned on, the EXV is closed for 700 steps, proofreading the 0-step position, and re-opening at a maximum of 480.
- Startup:
Adjust from 480 to the initial position, (the initial opening is determined by the ambient temperature), maintain for a period of time. EXV is controlled according to suction superheat, exhaust, and compressor speed.
- When the outdoor unit is in standby:
The EXV is at position 480 (steps).
- When the outdoor unit stops:
After the compressor shuts down for 1 minute, the EXV is fully closed first, and then opened to the initial position.

5.7 Outdoor Fan Control

For SCV-750EB:

Fan speed index	Fan speed (rpm)	
	FAN A	FAN B
0	0	0
1	150	0
2	190	0
3	230	0
4	270	0
5	330	0
6	150	150
7	170	170
8	190	190
9	210	210
10	230	230
11	250	250
12	270	270
13	290	290
14	310	310
15	330	330
16	350	350
17	370	370
18	400	400
19	430	430
20	450	450
21	470	470
22	510	510
23	550	550
24	580	580

25	610	610
26	640	640
27	680	680
28	710	710
29	750	750
30	780	780
31	800	800
32	830	830

For SCV-900EB and SCV-1800EB:

Fan speed index	Fan speed (rpm)	
	FAN A	FAN B
0	0	0
1	150	0
2	190	0
3	230	0
4	270	0
5	330	0
6	150	150
7	170	150
8	170	150
9	190	170
10	210	190
11	230	210
12	250	230
13	270	250
14	290	270
15	310	290
16	330	310
17	350	330
18	370	350
19	400	370
20	430	400
21	450	430
22	480	460
23	500	480
24	520	500
25	540	520
26	560	540
27	560	540
28	580	560
29	580	560
30	600	580
31	600	580
32	620	600

For SCV-1400EB:

Fan speed index	Fan speed (rpm)	
	FAN A	FAN B
0	0	0
1	150	0
2	190	0
3	230	0
4	270	0
5	330	0
6	150	150
7	170	170
8	170	170
9	190	190
10	210	210
11	230	230
12	250	250
13	270	270
14	290	290
15	310	310
16	330	330
17	350	350
18	370	370
19	400	400
20	430	430
21	470	470
22	510	510
23	550	550
24	600	600
25	650	650
26	680	680
27	700	700
28	720	720
29	750	750
30	780	780
31	800	800
32	830	830

6 Protection Control

6.1 High Pressure Protection Control

This control protects the refrigerant system from abnormally high pressure and protects the compressor from transient spikes in pressure.

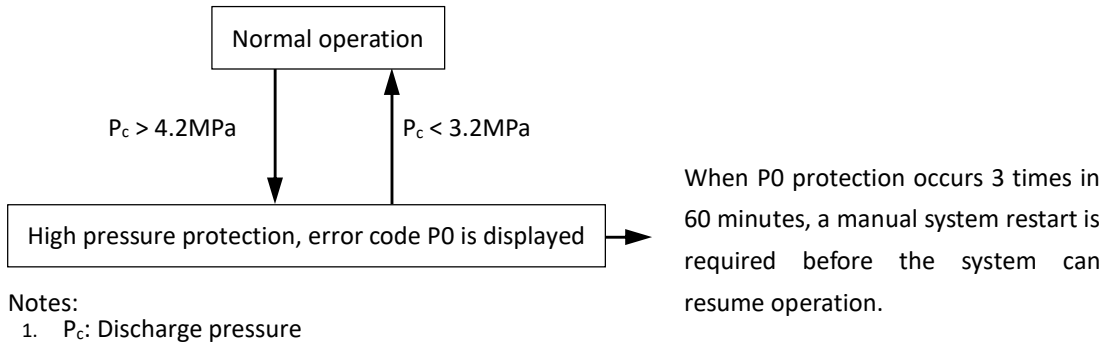

When the discharge pressure rises above 4.2MPa the system displays P0 protection and all units stop running. When the discharge pressure drops below 3.2MPa, the compressor enters re-start control.

6.2 Low Pressure Protection Control

This control protects the refrigerant system from abnormally low pressure and protects the compressor from transient drops in pressure.

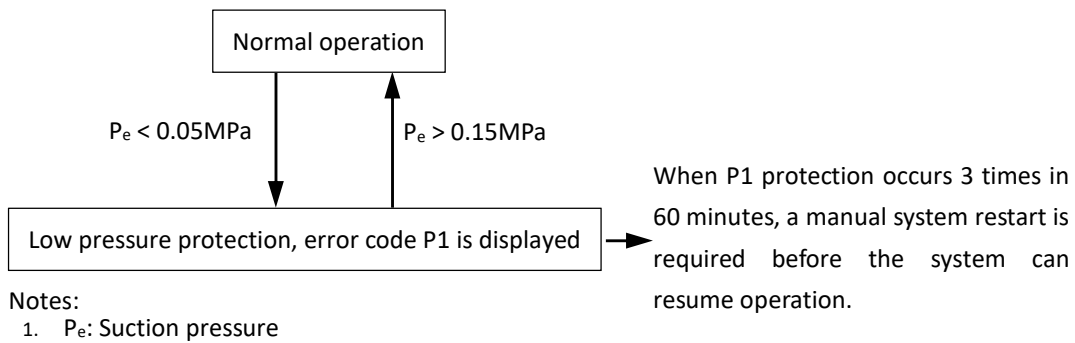

6.3 Discharge Temperature Protection Control

This control protects the compressor from abnormally high temperatures and transient spikes in temperature.

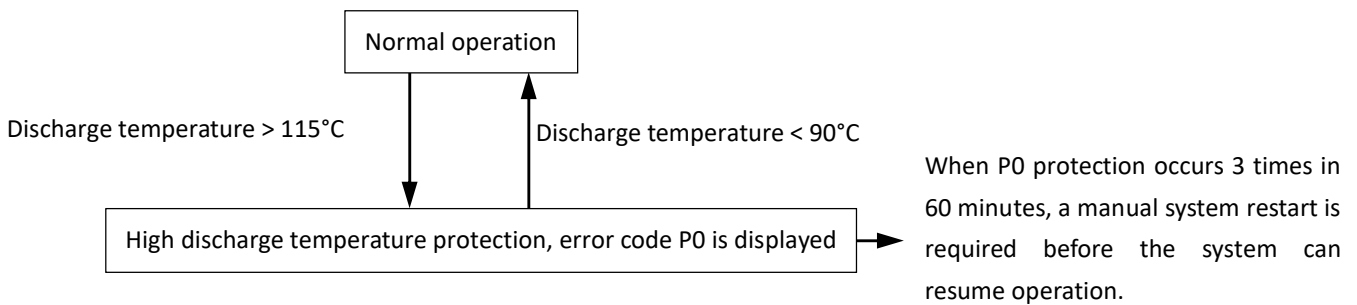

When the discharge temperature rises above 115°C the system displays P0 protection and all the units stop running. When the discharge temperature drops below 90°C , the compressor enters re-start control.

6.4 Compressor and Inverter Module Protection Control

For SCV-750EB and SCV-1400EB:

The protection current for SCV-750EB is 54A, for SCV-1400EB is 106A.

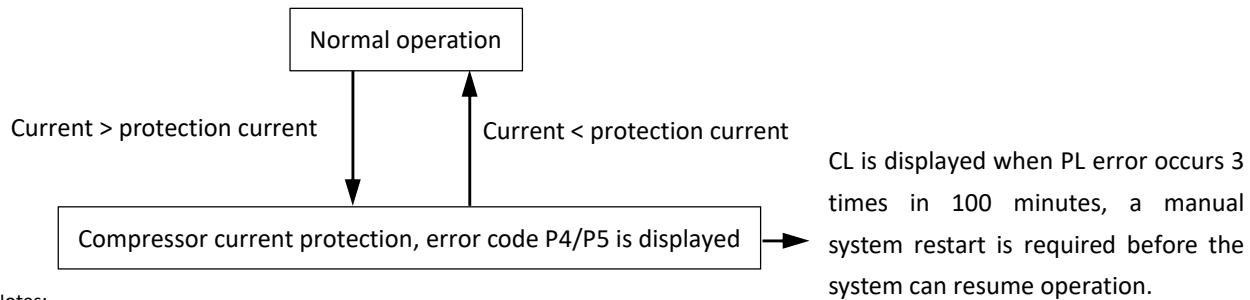

Notes:

1. P4 is the protection for System A, P5 is the protection for System B.

For SCV-900EB and SCV-1800EB:

The protection current for SCV-900EB is 33A, for SCV-1800EB is 60A.

This control protects the compressors from abnormally high currents and protects the inverter modules from abnormally high temperatures. It is performed for each compressor and inverter module.

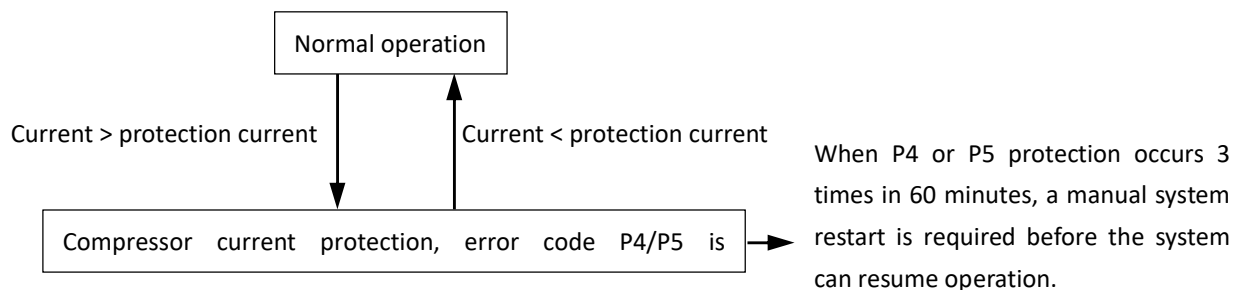

Notes:

1. P4 is the protection for System A, P5 is the protection for System B.

When the compressor current rises above protection current, the system displays P4 or P5 protection and all the units stop running. When the compressor current drops below protection current, the compressor enters re-start control.

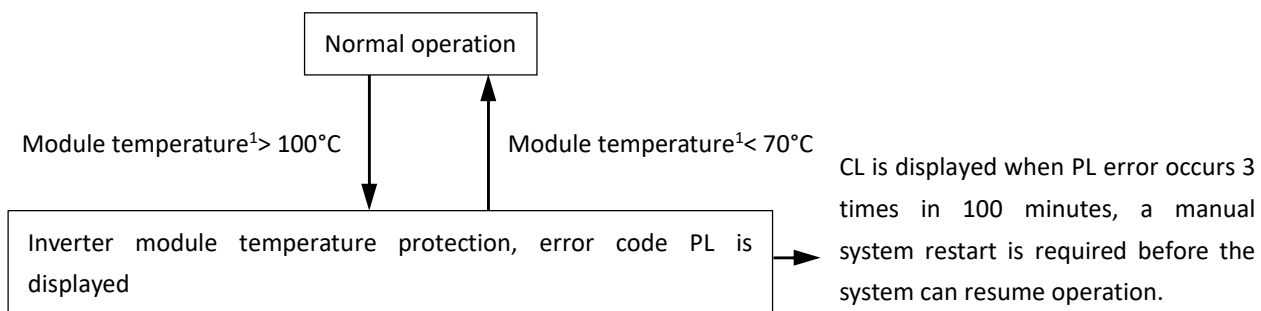

Notes:

1. The module temperature is calculated by inverter module.

When the module temperature rises above 100°C, the system displays PL protection and all the units stop running. When the module temperature drops below 70°C, the compressor enters re-start control.

6.5 Voltage Protection Control

This control protects the units from abnormally high or abnormally low voltages.

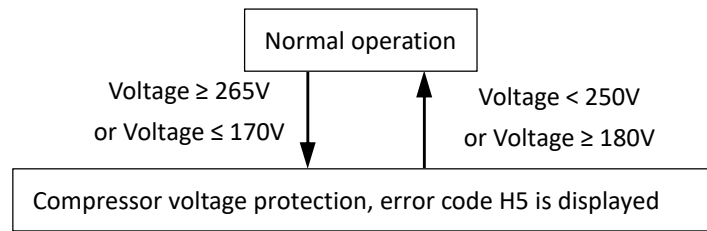

When the phase voltage of AC power supply is at or above 265V for more than 30 seconds, the system displays H5 protection and all the units stop running. When the phase voltage drops below 250V for more than 30 seconds, the unit restart once the compressor re-start delay has elapsed. When the phase voltage is below 170V for more than 30 seconds, the system displays H5 protection and all the units stop running. When the AC voltage rises to at or above 180V for more than 30 seconds, the refrigerant system restarts once the compressor re-start delay has elapsed.

6.6 DC Fan Motor Protection Control

This control protects the DC fan motors from abnormal power supply. DC fan motor protection occurs when the fan module does not receive any feedback from the fan motor.

When DC fan motor protection control occurs the system displays the PU error code and the unit stops running. When PU protection occurs 10 times in 120 minutes, the FF error is displayed. When an FF error occurs, a manual system restart is required before the system can resume operation.

6.7 Water Side Heat Exchanger Anti-freeze Protection Control

When water side heat exchanger anti-freeze protection occurs the system displays error code Pb and all the units stop running.

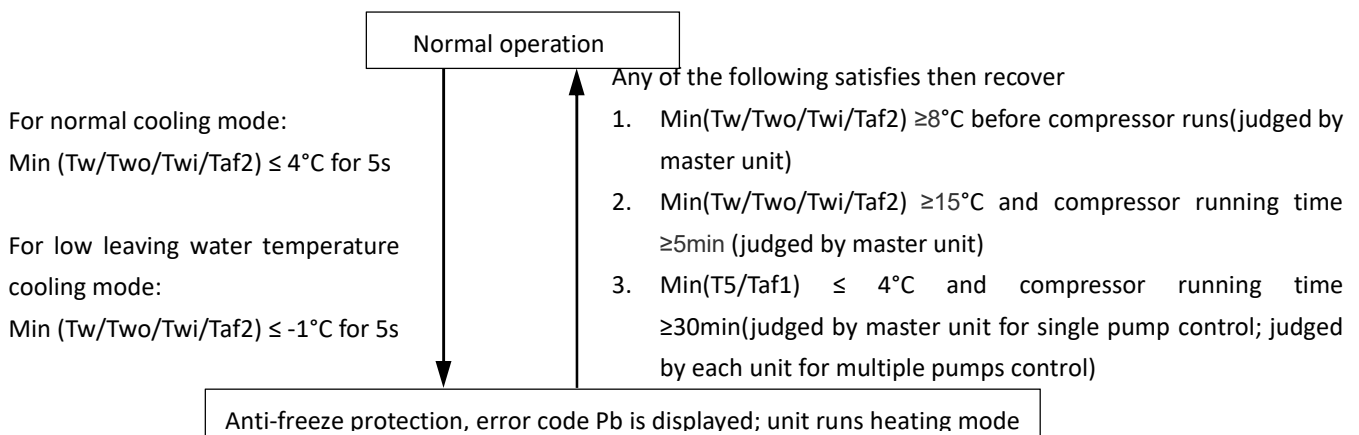

6.8 Air Side Heat Exchanger High Temperature Protection Control

This control protects the air side heat exchanger from high temperature.

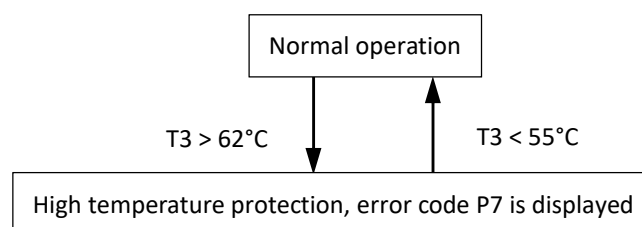

Note:

1. T3: Air side heat exchanger refrigerant outlet temperature

When the air side heat exchanger refrigerant outlet temperature (T3) rises above 62°C, the system displays P7 protection and all the units stop running. When the air side heat exchanger refrigerant outlet temperature (T3) drops below 55°C, the compressor enters re-start control.

6.9 Water Side Heat Exchanger Temperature Difference Protection Control

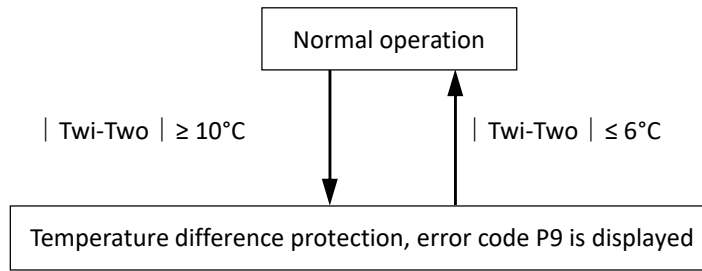

Notes:

1. T_{wi} : Water side heat exchanger inlet temperature;
2. T_{wo} : Water side heat exchanger outlet temperature.

When the temperature difference rises at or above 10°C , the system displays P9 protection and all the units stop running. When the temperature difference drops below 6°C , the compressor enters re-start control.

6.10 Water Side Heat Exchanger Low Temperature Protection Control

This control protects the water side heat exchanger from ice formation.

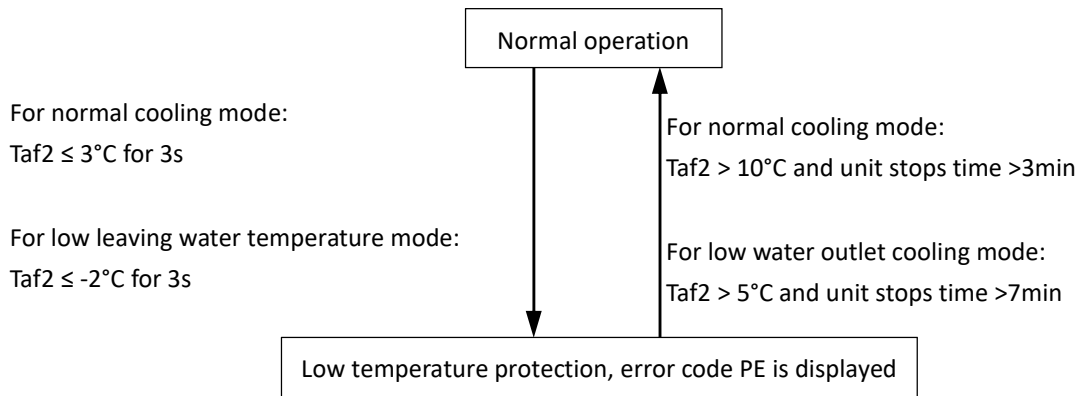

Notes:

1. T_{af2} : Water side heat exchanger anti-freezing temperature 2

6.11 Water Side Heat Exchanger Low Pressure Protection Control

This control protects the water side heat exchanger from ice formation.

- Normal cooling mode

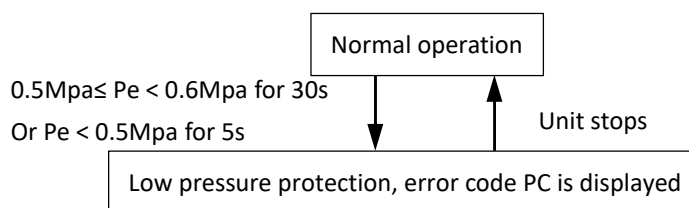

In normal cooling mode, when $0.5\text{Mpa} \leq P_e < 0.6\text{Mpa}$ for 30s or $P_e < 0.5\text{Mpa}$ for 5s, the system displays PC protection and all the units stop running. When the unit stop, the compressor enters re-start control.

- Low leaving water temperature mode

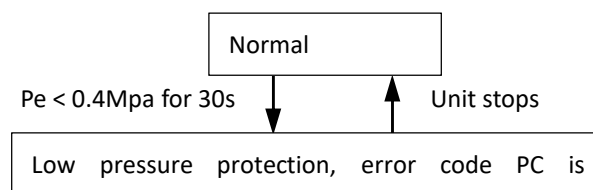

In low water temperature cooling mode, when the suction pressure drops below 0.4Mpa for 30s, the system displays PC protection and all the units stop running. When the unit stop, the compressor enters re-start control.

7 Special Control

7.1 Outdoor Unit Duty Cycling

In systems with multiple outdoor units, outdoor unit duty cycling is used to balance the compressor running time. Outdoor unit duty cycling occurs whenever all the outdoor units stop running (either because the leaving water set temperature has been reached or because a master unit error has occurred):

Take 16 units in parallel as an example:

- First cycle:

When the outdoor units are powered on for the first time, if there is a load requirement, 50% of the units turn on starting with the 0# master unit to higher address slave units. As the leaving water temperature approaches its set temperature, units shut down in succession, starting with the unit with the highest address.

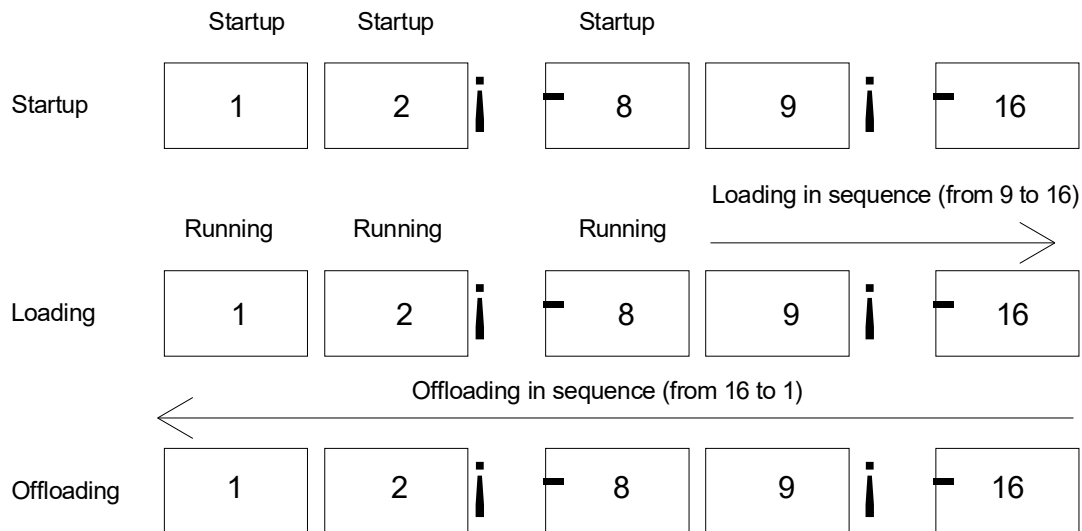

- Second cycle:

The next time a load requirement exists (or following a master unit error), the units turn on starting with the highest address unit to lower address units. As the leaving water temperature approaches its set temperature, units shut down in succession, starting with the unit with the lowest address.

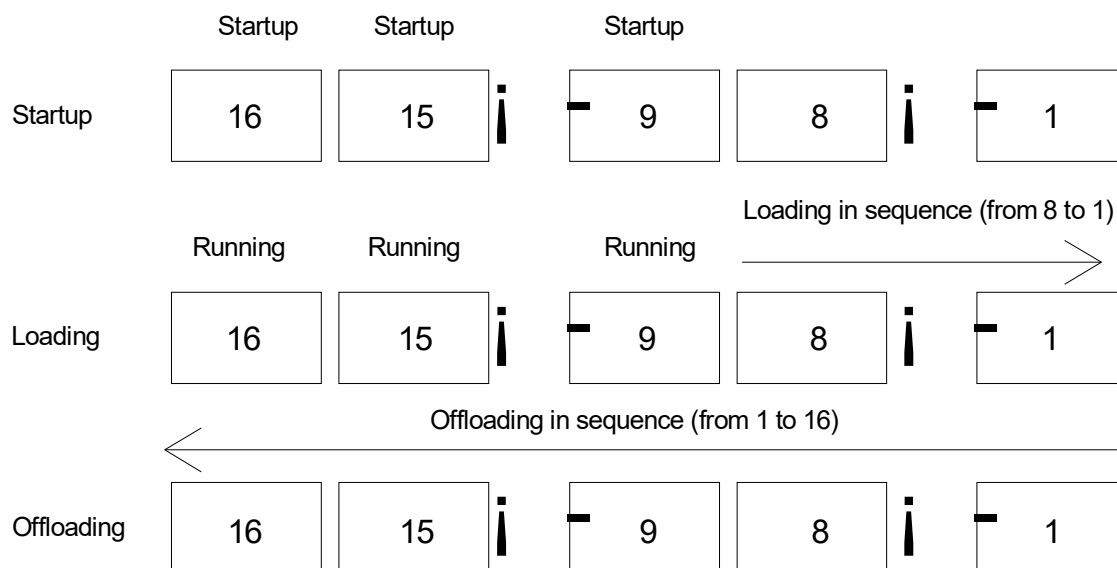

- Subsequent cycles will repeat the actions of the first and second cycles

Notes:

1. The address settings on the outdoor unit main PCBs for master unit and slave unit do not change.

7.2 Defrosting Operation

In order to recover heating capacity, the defrosting operation is conducted when the outdoor unit air side heat exchanger is performing as a condenser. The defrosting operation is controlled according to outdoor ambient temperature, air side heat exchanger refrigerant temperature, water inlet temperature, compressor running time and defrosting time.

Component	Wiring diagram label	4-10kW	Control functions and states
Inverter compressor	COMP	●	Runs at defrosting operation rotation speed
DC fan motor	FAN	●	Off
Electronic expansion valve	EXV	●	Fully open
Four-way valve	4-WAY	●	Off

7.3 TEMP-SWITCH control

The function of “TEMP-SWITCH” must be set by wired controller for two target water temperature. For cooling and heating mode, different water temperatures can be switched just by one-touch. The operation method is as follows:

- Setting: “USER MENU”——“DOUBLE SETPOINT”

DOUBLE SETPOINT	
DOUBLE SETPOINT	◀DISABLE ▶
SETPOINT COOL_1	◀ 16 ▶ °C
SETPOINT COOL_2	◀ 20 ▶ °C
SETPOINT HEAT_1	◀ 16 ▶ °C
SETPOINT HEAT_2	◀ 25 ▶ °C
<input type="button" value="OK"/> <input type="button" value="↕"/> <input type="button" value="↔"/>	

- Wire connection: Shorting the terminal block CN110 at slave board (Refer to the Part 4, 3.1 Single unit) for SCV-750EB and SCV-1400EB. Connect a switch between 20 and 25 terminals of block XT2 (Refer to the Part 4, 3.1 Single unit) for SCV-900EB and SCV-1800EB. If the switch is off, unit operates at first target water temperature. If the switch is on unit operates at second target water temperature.

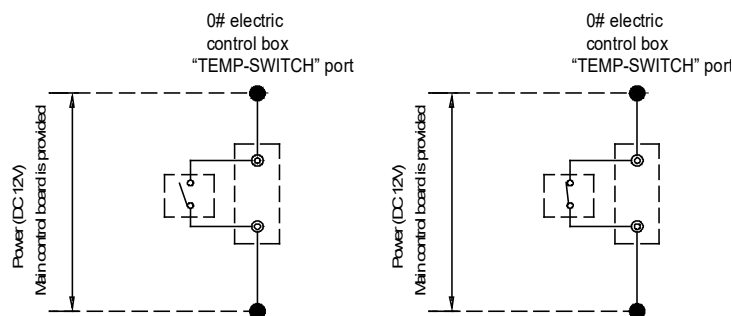

Part 4

Diagnosis and Troubleshooting

1 Electric Control Box Layout.....	44
2 PCB Introduction	46
3 Wiring diagram	59
4 Error Code Table.....	66
5 Troubleshooting	68
6 Drive Module Failure.....	139
7 Appendix.....	152

1 Electric Control Box Layout

For SCV-750EB

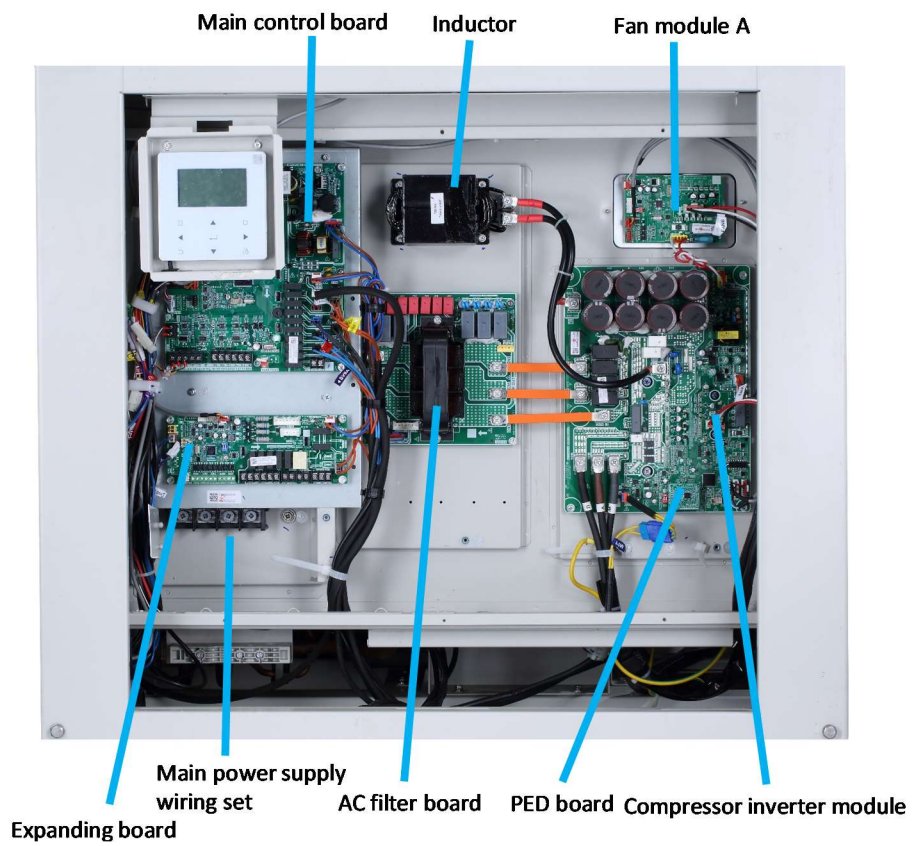

For SCV-1400EB

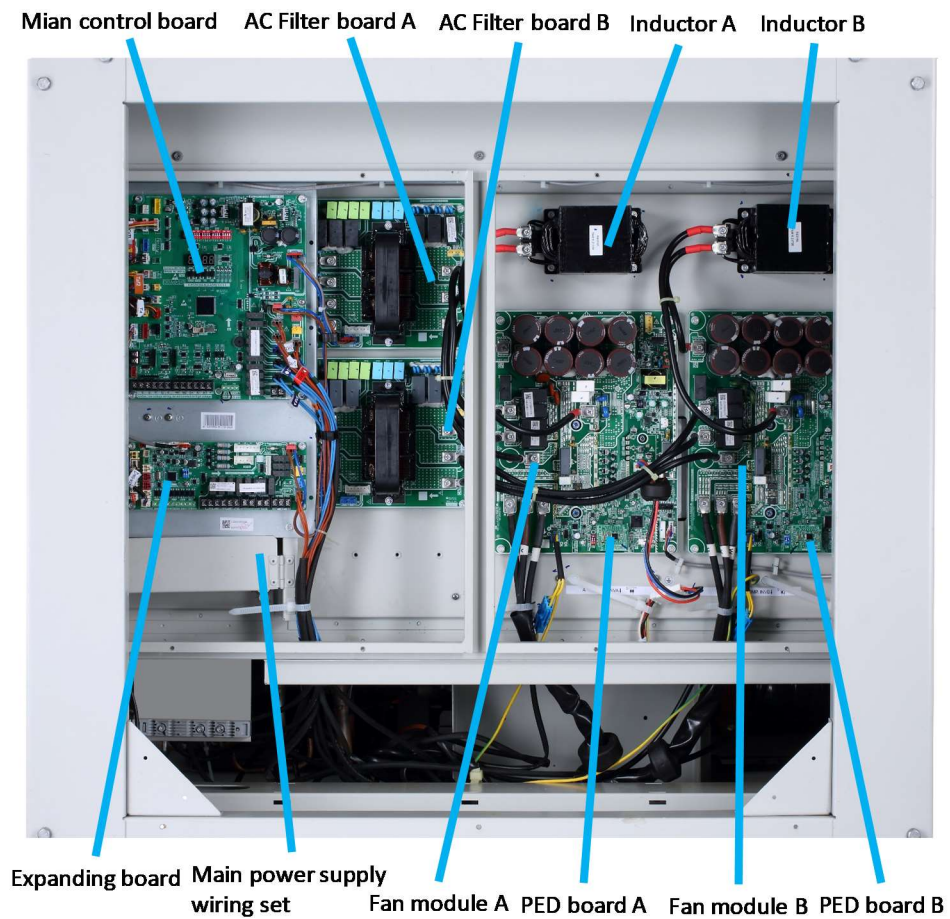

For SCV-900EB and SCV-1800EB

- Electric control box side view-upper layer

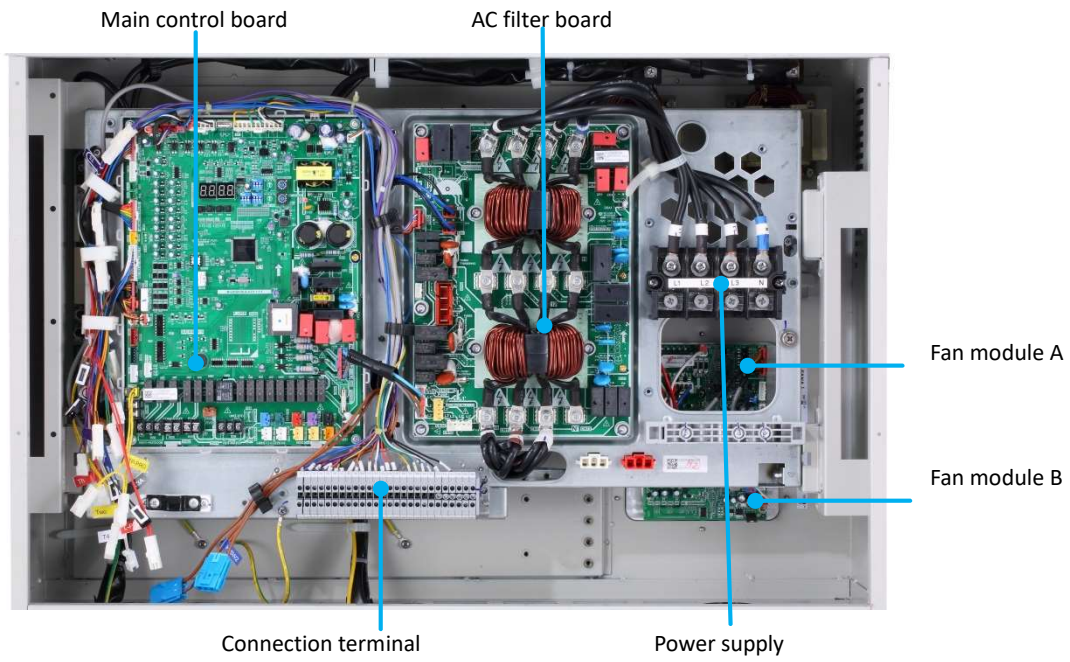

- Electric control box side view-bottom layer

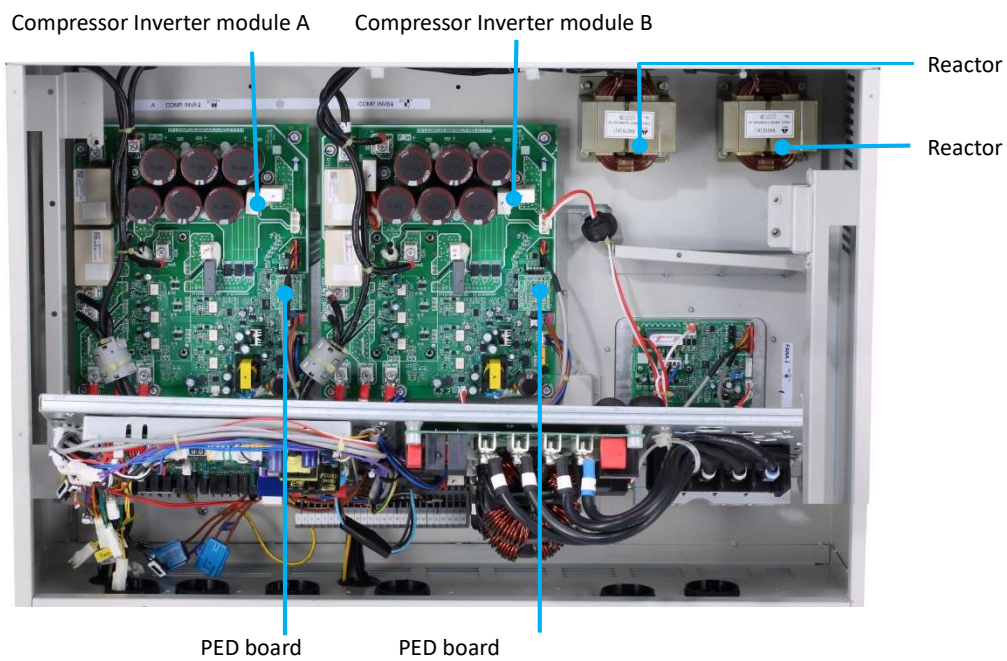

- Sinclair electric control side view

For SCV-1800EB only



2 PCB Introduction

2.1 Types

Aqua thermal 75kW, 90kW and 140kW unit have one main control board, two compressor inverter module board, two DC fan inverter module board and one filter board.

Aqua thermal 180kw unit have two main control board, four compressor inverter module board, four DC fan inverter module board and two filter board.

2.2 Main PCB

2.2.1 Main PCB component

For SCV-750EB and SCV-1400EB

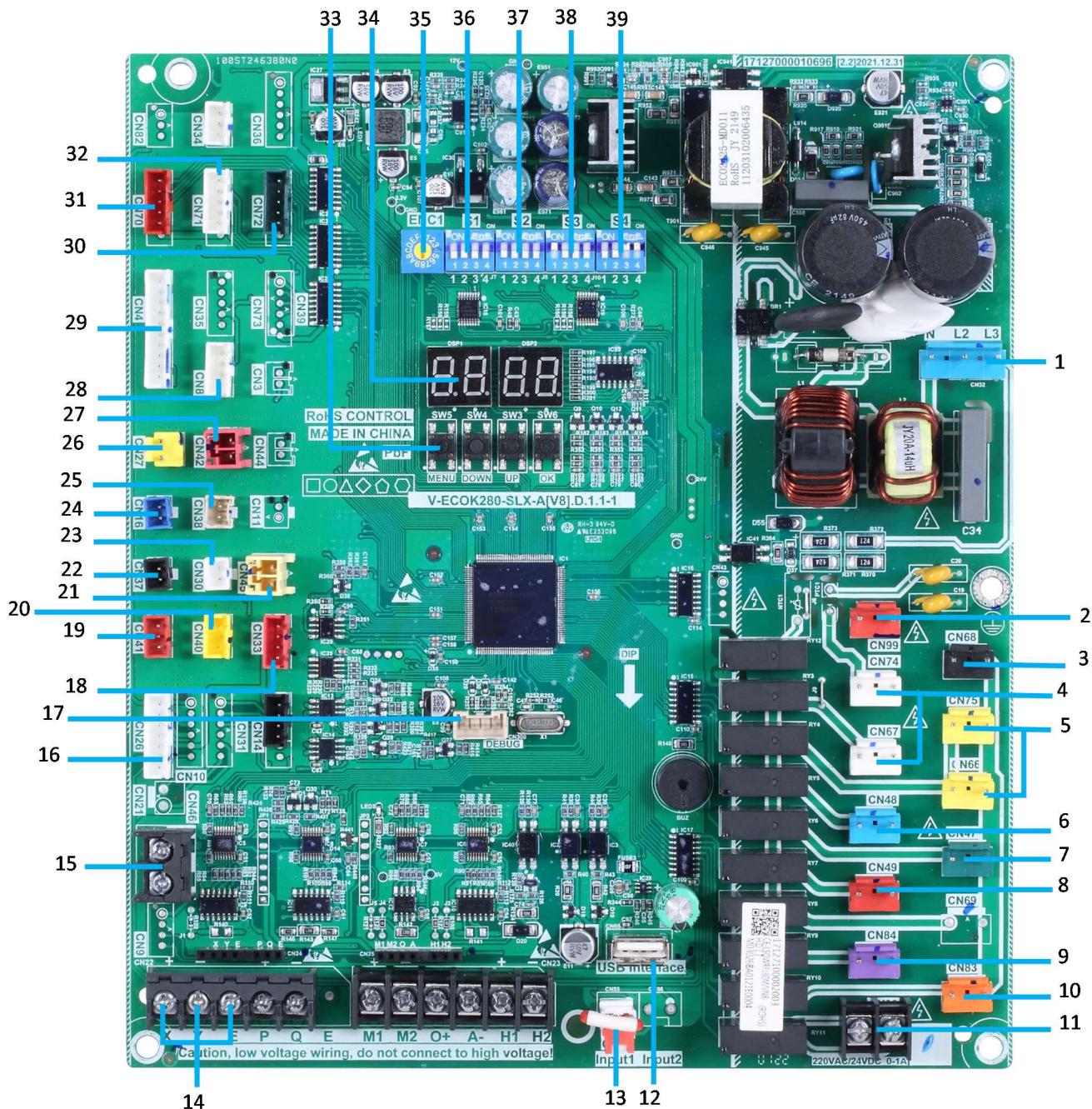

Label	Code	Port	Explanation	Voltage
1	CN32	POWER	Power supply port	220-240V
2	CN99		Expanding board power connector	220-240V
3	CN68	PUMP	Pump contactor control port (connected in factory)	220-240V
4	CN74/CN67	CCH	compressor heating belt	220-240V

5	CN75/CN66	EVA-HEAT	Plate heat exchanger electric heating belt	220-240V
6	CN48	ST1	Four-way valve	220-240V
7	CN47	SV6	One-way solenoid valve	220-240V
8	CN49	SV5	One-way solenoid valve	220-240V
9	CN84	SV8A	One-way solenoid valve	220-240V
10	CN83	SV8B	One-way solenoid valve	220-240V
11	CN93	ALARM	Fault alarm port	/
12	CN65	USB	USB program burning port	DC5V
13	CN28	PH-PRO	Three-phase protector signal detection port	DC12V
14	CN22	XYE	External unit parallel connection communication port & external unit and wired controller communication port	DC5V
15	CN46		Wired controller power supply port	DC12V
16	CN26	O-Motor	Module board PTC relay control port/Module board communication port	DC12V/DC5V
17	CN300	DEBUG	Main control program burn port(WizPro200RS programmer)	DC3.3V
18	CN33	MS	Expanding board communication port	DC12V/DC5V
19	CN41		Low pressure sensor	DC3.3V
20	CN40		High pressure sensor	DC3.3V
21	CN45	Taf2	Water side antifreeze temperature sensor	DC3.3V
22	CN37	T3A	Pipe temperature sensor of the condenser	DC3.3V
23	CN30	T4	Outdoor ambient temperature sensor	DC3.3V
24	CN16	T3B	Pipe temperature sensor of the condenser	DC3.3V
25	CN38	TP2	DC inverter compressor B discharge temperature sensor	DC3.3V
26	CN27	TP-PRO	Discharge temperature controller	DC3.3V
27	CN42	L-PRO	Low pressure switch	DC3.3V
28	CN8	T6A	Refrigerant inlet temperature of EVI plate heat exchanger	DC3.3V
		T6B	Refrigerant outlet temperature of EVI plate heat exchanger	DC3.3V
29	CN4	Twi	Unit water inlet temperature sensor	DC3.3V
		Th	System suction temperature sensor	DC3.3V
		Two	Unit water outlet temperature sensor	DC3.3V
		Tz/7	Coil final outlet temperature sensor	DC3.3V
		Tp1	DC inverter compressor A discharge temperature sensor	DC3.3V
30	CN72	EXVC	Electronic expansion valve A	DC12V
31	CN70	EXVA	Electronic expansion valve B	DC12V
32	CN71	EXVB	Electronic expansion valve C	DC12V
33	SW3	UP	Up button	DC3.3V
	SW4	DOWM	Down button	DC3.3V
	SW5	MENU	Menu button	DC3.3V
	SW6	OK	Confirm button	DC3.3V
34	DSP1/DSP2		Digital tube	DC3.3V
35	ENC1		ADDRESS DIP switch	DC3.3V
36	S1	S1-1	0: normal control mode; 1: remote control mode	DC3.3V
		S1-3	0: Single water pump control mode; 1: Multiple water pumps control mode	DC3.3V
37	S2	/	Reserve	DC3.3V

20	CN71	System electronic expansion valve(For cooling)	DC12V
21	CN72	Electronic expansion valve(For EVI)	DC12V
22	CN70	System electronic expansion valve1	DC12V
23	CN60	Outdoor units communication or HMI communication port	DC5V
24	CN61	Outdoor units communication or HMI communication port	DC5V
25	CN64	Fan inverter module communication port	DC5V
26	CN65	Compressor inverter module communication port	DC5V
27	CN300	Program burn import (WizPro200RS programming device)	DC5V
28	IC10	EEPROM chip	DC5V
29	CN1	Temperature sensors input port. T4: Outdoor ambient temperature sensor T3A/T3B: Pipe temperature sensor of the condenser T6A: Refrigerant inlet temperature of EVI plate heat exchanger T6B: Refrigerant inlet temperature of EVI plate heat exchanger	DC5V
30	CN16	System pressure sensor	DC5V
31	CN31	Temperature sensors input port Th: System suction temperature sensor Taf2: Water side antifreeze temperature sensor Two: Unit water outlet temperature sensor Twi: Unit water inlet temperature sensor Tw: Total water outlet temperature sensor when several units are connected in parallel	DC5V
32	CN69	Temperature sensors input port Tp1 :DC inverter compressor 1 discharge temperature sensor Tp2:DC inverter compressor 2 discharge temperature sensor Tz: Coil final outlet temperature sensor	DC5V
33	CN19	Low voltage protection switch	DC5V
34	CN91	Three-phase protector output switch	DC5V
35	CN58	Fan relay driver port	DC12V
36	CN8	Remote function of cool/heat port	DC12V
37	CN8	Remote function of on/off port	DC12V
38	CN8	Water flow switch port	DC12V
39	SW3-SW6	SW3: Up button a) Select different menus when enter menu selection. b) For spot inspection in conditions. SW4: Down button a) Select different menus when enter menu selection. b) For spot inspection in conditions. SW5: Menu button Press to enter menu selection, short press to return to the previous menu. SW6: OK button Enter the submenu or confirm the function selected by short pressing.	DC5V
40	USB	Program burn import (USB)	DC5V
41	DSP1/DSP2	Digital tube 1) In case of stand-by, the address of the module is displayed; 2) In case of normal operation, 10. is displayed (10 is followed by dot). 3) In case of fault or protection, fault code or protection code is displayed.	DC5V
42	S5	S5: Dip switch S5-3: Normal control, valid for S5-3 OFF (factory default) Remote control, valid for S5-3 ON.	DC5V



43	CN7	Target water temperature switching port	DC12V
44	ENC2	Power DIP switch for capacity selection. (SCV-900EB defaults 2; SCV-1800EB defaults 6)	DC5V
45	CN74	Power supply port of the HMI	DC9V
46	ENC4	NET_ADDRESS DIP switch (0~15)	DC5V
47	S12	S12: Dip switch S12-1: Valid for S12-1 ON (factory default) S12-2: Single water pump control, valid for S12-2 OFF (factory default) Multiple water pumps control, valid for S12-2 ON。	DC5V

2.2.2 Main PCB field setting

Multiple pumps control: output pump signal on all units.

Single pump control: only the master unit output pump signal, no pump signal output on the slave units.

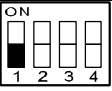
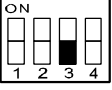
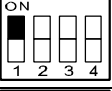
For SCV-750EB and SCV-1400EB

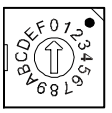
Switch	Description	ON	OFF	Default factory setting
 S1-1	Control mode	Remote control	Normal control	OFF
 S1-3	Water pump	Multiple water pumps control	Single water pump control	OFF
 S3-1	-	-	-	ON
 S4	DIP switch for capacity selection	-	-	SCV-750EB: 0011
 S4	DIP switch for capacity selection	-	-	SCV-1400EB: 0111
 ENC1	0-F valid for unit address setting on the DIP switches 0 indicates the master unit and 1-F the auxiliary units (parallel connection)	-	-	0

Note:

1. Wiring of "HEAT/COOL" weak electric port

The remote function of "HEAT/COOL" must be set by DIP switch. The remote function "HEAT/COOL" is effective when S1-1or S5-3 is chosen ON, at the same time, the wire controller is out of control.

Corresponding parallel connect the "HEAT/COOL" port of the main unit's electric control box, then, connect the "ON/OFF" signal (provide by user) to the "HEAT/COOL" port of main unit as follows.

Wiring method: Shorting the terminal block CN138 at slave board inside the electric control box to enable the remote function of "HEAT/COOL".

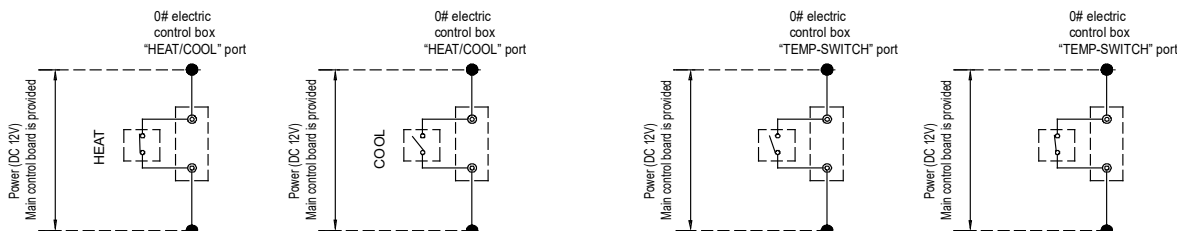



2. Wiring of "TEMP-SWITCH" weak electric port

The function of "TEMP-SWITCH" must be set by wired controller for two setting water temperature. For cooling and heating mode.

Wiring method: Shorting the terminal block CN110 at slave board inside the electric control box to choose the target water temperature.

For SCV-900EB and SCV-1800EB

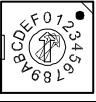
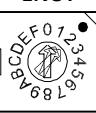
Switch	Description	ON	OFF	Default factory setting
 S5-3	Control mode	Remote control	Normal control	OFF
 S12-1	Default setting	Default setting	-	ON
	S12-2	Multiple pumps control	Single pump control	OFF
 ENC2	DIP switch for capacity selection	-	-	SCV-900EB : 2 SCV-1800EB: 6
 ENC4	Address setting 0: master unit 1,2,3...F: slave units	-	-	SCV-900EB: 0 SCV-1800EB: 0 and 1

Note:
When using remote control function, first is to dial the S5-3 switch to ON. The operation method is as below:
1. Remote ON/OFF:
Connect a switch between 15 and 24 terminals of block XT2 (Refer to the Part 4, 3.1 Single unit) which can be turned on/off at any time. If the switch is closed, unit turns on. If the switch is open, unit turns off.

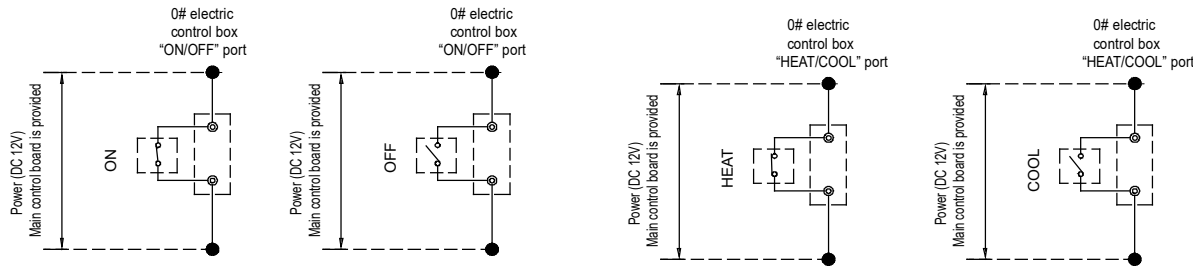

2. Remote cool/heat:
Connect a switch between 14 and 23 terminals of block XT2 (Refer to the Part 4, 3.1 Single unit) which can change operation mode at any time. If the switch is closed, unit runs in heating mode. If the switch is open, unit runs in cooling mode.

2.2.3 Digital display output

For SCV-750EB, SCV-900EB and SCV-1400EB:

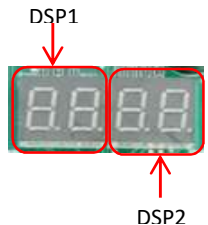
Outdoor unit state	Parameters displayed on DSP1	Parameters displayed on DSP2	
Standby	0	1	
Normal operation	Running speed of compressor A in rotations per second	Running speed of compressor B in rotations per second	
Error or protection	-- or placeholder	Error or protection code	

For SCV-1800EB:

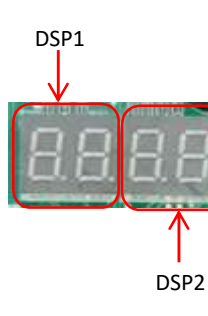
Outdoor unit state	Master parameters displayed		Slave parameters displayed		
	DSP1	DSP2	DSP1	DSP2	
Standby	Address	Online number	Address	No display	
Normal operation	Running speed of compressor A in rotations per second	Running speed of compressor B in rotations per second	Running speed of compressor A in rotations per second	Running speed of compressor B in rotations per second	
Error or protection	-- or placeholder		Error or protection code		

2.3 Compressor Inverter Module Board

2.3.1 Compressor Inverter Module PCB component

For SCV-750EB and SCV-1400EB

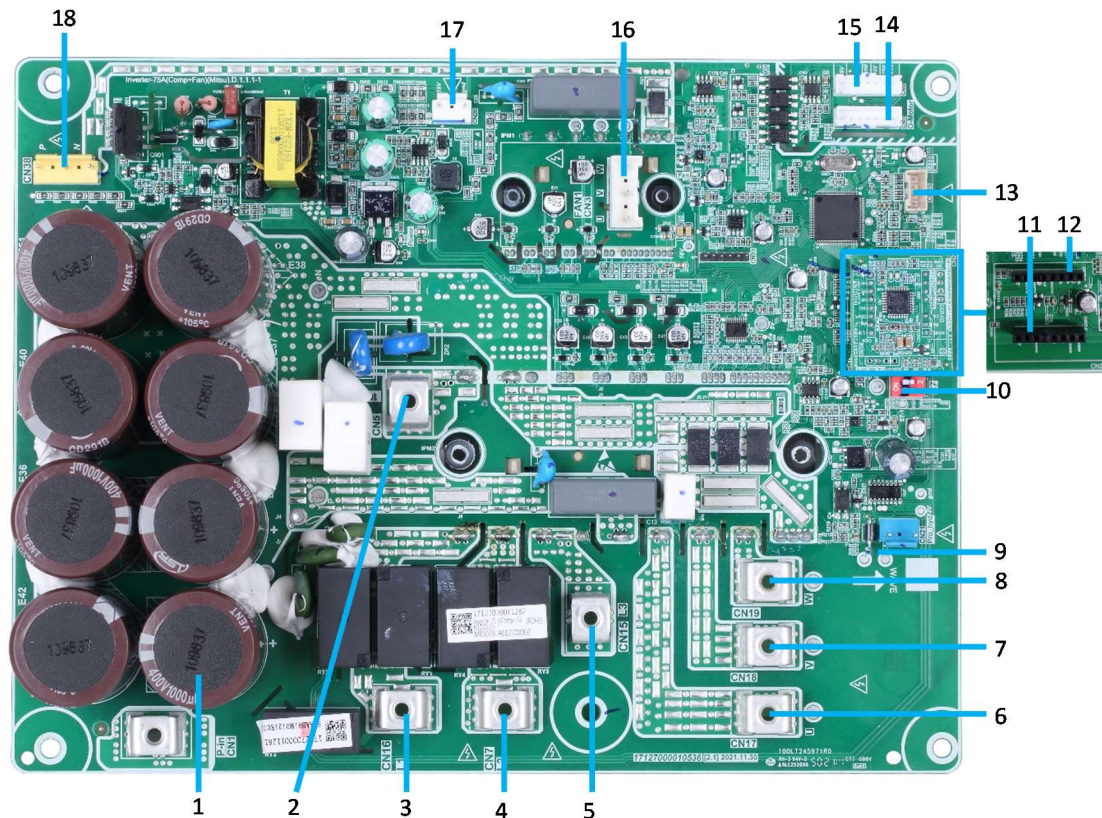

Label	Code	Port	Explanation	Voltage
1	CN1	P-in	Reactor output port	
2	CN5	P-out	Reactor input port	
3	CN16	L1	Power supply for module board	380-415V
4	CN7	L2		
5	CN15	L3		
6	CN17	U	Compressor output	
7	CN18	V		
8	CN19	W		
9	CN21	H-SW	High pressure switch	
10	S7		module address setting system A: 00; system B: 01	
11	CN27-1		PED board connection port	DC12V/DC5V
12	CN27-2		PED board connection port	DC12V/DC5V
13	CN25	DEBUG	Driver burn port (WizPro200RS programmer)	DC5V
14	CN8	O-Motor	Module Board PTC Relay Control Port/Module Board Communication Port	DC12V/DC5V
15	CN9	O-Motor	Module Board PTC Relay Control Port/Module Board Communication Port	DC12V/DC5V
16	CN3	UVW	Fan output port	
17	CN26		Fan control power supply output port	DC19V
18	CN39	P N	Fan power supply output port	DC565V

For SCV-900EB and SCV-1800EB:

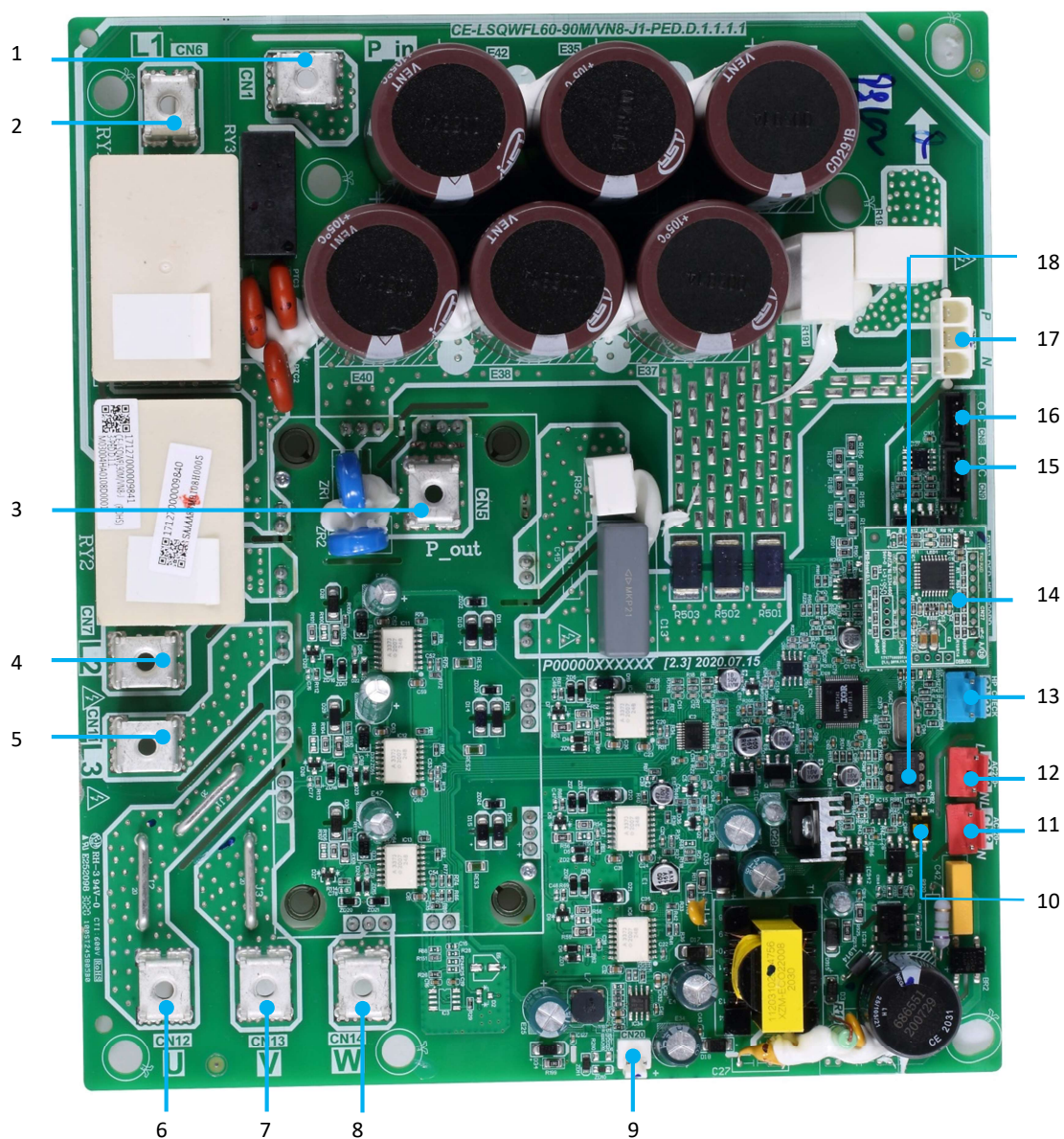

Label	Code	Port	Voltage
1	CN1	Reactor output port	DC565V
2	CN6	Three-phase power supply in (L1)	400VAC
3	CN5	Reactor input port	DC565V
4	CN7	Three-phase power supply in (L2)	400VAC
5	CN11	Three-phase power supply in (L3)	400VAC
6	CN12	Compressor connection port U	VUV=VUW=VVW 0-380V AC
7	CN13	Compressor connection port V	
8	CN14	Compressor connection port W	
9	CN20	Power supply for fan module	DC20V
10	S7	Address DIP switch	DC5V
11	CN3	Power supply for compressor board	AC230
12	CN2	Power supply for compressor board	
13	CN23	High pressure switch connection port	DC12V
14	CN22	PED board	DC12V
15	CN9	Compressor board communication port	DC5V
16	CN8	Compressor board communication port	DC5V

17	CN38	Power supply for fan module board	DC565V
18	IC25	EEPROM	DC5V

2.3.2 Compressor Inverter Module PCB field setting

Switch	Description	S7-1	S7-2
<p style="text-align: center;">S7</p> 	Compressor A inverter module address setting	OFF	OFF
	Compressor B inverter module address setting	OFF	ON

2.4 Fan Module Board

2.4.1 Fan Module Board component

For SCV-750EB and SCV-1400EB

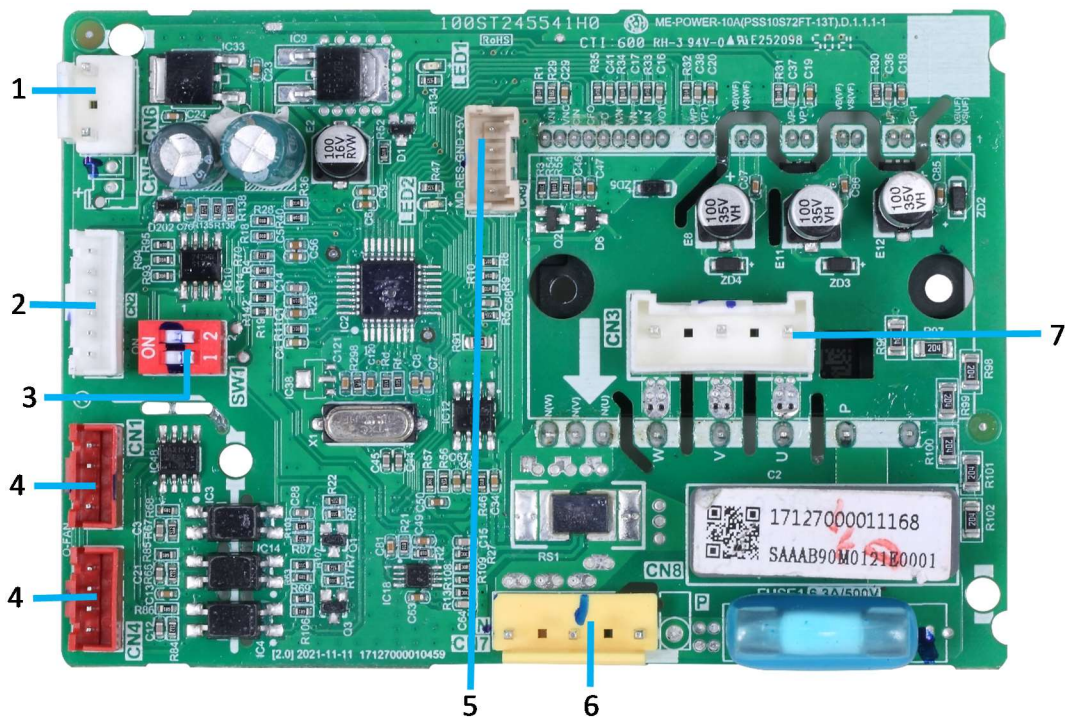

Label	Code	Port	Explanation	Voltage
1	CN6		Fan module control power supply output port	DC19V
2	CN12		Reserve	
3	SW1		Fan module address setting	
4	CN1/CN4		Fan module communication port	DC5V
5	CN9	DEBUG	Program burn port (WizPro200RS programmer)	DC5V
6	CN7	P N	Fan module power supply port	DC565V
7	CN3	UVW	Fan output port	

For SCV-900EB and SCV-1800EB

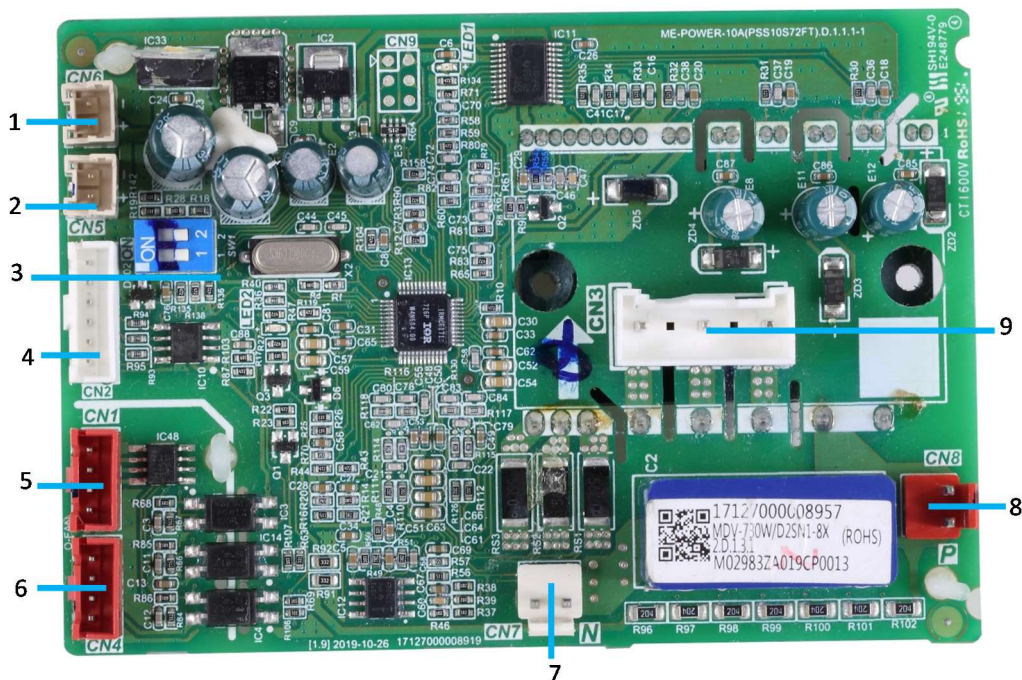

Label	Code	Port	Voltage
1	CN6	Power supply port	DC20V
2	CN5	Power supply port	DC20V
3	SW1	Address DIP switch	DC5V
4	CN2	Program input port	DC5V
5	CN1	Fan module board communication port	DC5V
6	CN4	Fan module board communication port	DC5V
7	CN7	DC bus voltage N	DC565V
8	CN8	DC bus voltage P	DC565V
9	CN3	Fan output port U/V/W	AC 0~380V

2.4.2 Fan Module PCB field setting

Switch	Description	S1-1	S1-2
	Fan A inverter module address setting	OFF	OFF
	Fan B inverter module address setting	OFF	ON

2.5 AC Filter Board

For SCV-750EB and SCV-1400EB

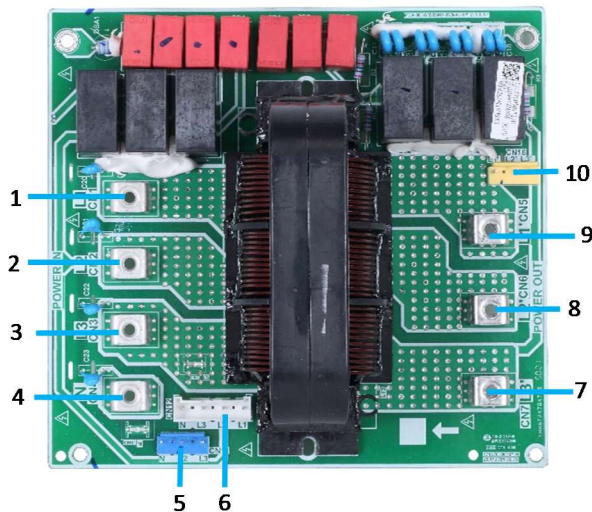

Label	Code	Port	Explanation	Voltage
1	CN1	L1	Input port L1	380-415V
2	CN2	L2	Input port L2	
3	CN3	L3	Input port L3	
4	CN4	N	Input port N	
5	CN11		Power supply port for main PCB	
6	CN12		Port for three phase protector (reserve)	380-415V
7	CN7	L3'	Output port L3	380-415V
8	CN6	L2'	Output port L2	
9	CN5	L1'	Output port L1	
10	CN16		Three phase water pump power supply port (reserve)	380-415V

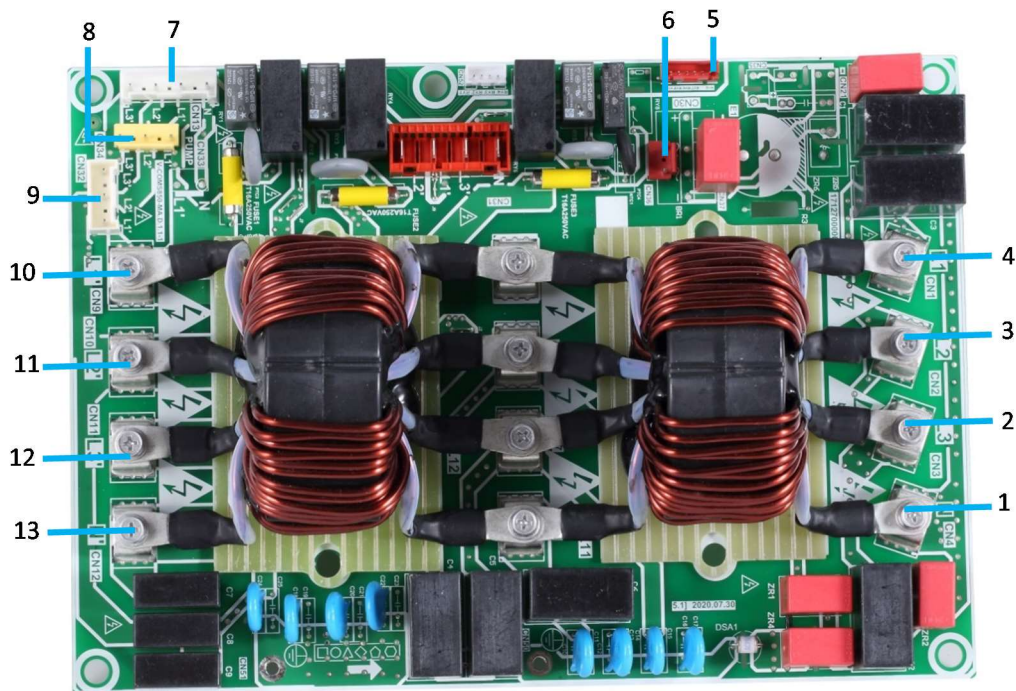

Label	Code	Port	Voltage
1	CN4	Input port N	400VAC
2	CN3	Input port L3	400VAC
3	CN2	Input port L2	400VAC
4	CN1	Input port L1	400VAC
5	CN30	Relay driver signal for compressor from main PCB	DC12V
6	CN36	Power supply for compressor inverter module	230VAC
7	CN13	Power supply port for main PCB/Three phase sequence detection port	230VAC
8	CN34	Power supply for three phase water pump	400VAC
9	CN32	Port for three phase protector	400VAC
10	CN9	Output port L1'	400VAC
11	CN10	Output port L2'	400VAC
12	CN11	Output port L3'	400VAC
13	CN13	Output port N	400VAC
14	CN51	Ground screw hole	/
15	CN50	Ground screw hole	/

2.6 PED Board

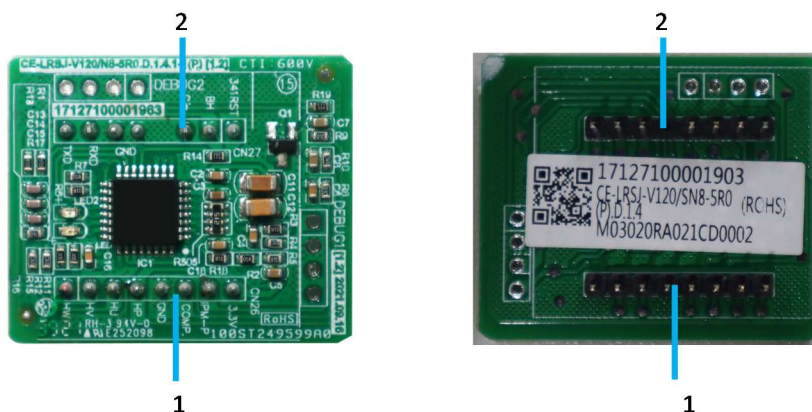

Label	Code	Port	Explanation	Voltage
1	CN26		For connecting compressor module board	/
2	CN27		For connecting compressor module board	/

2.7 Slave PCB Board

For SCV-750EB and SCV-1400EB only:

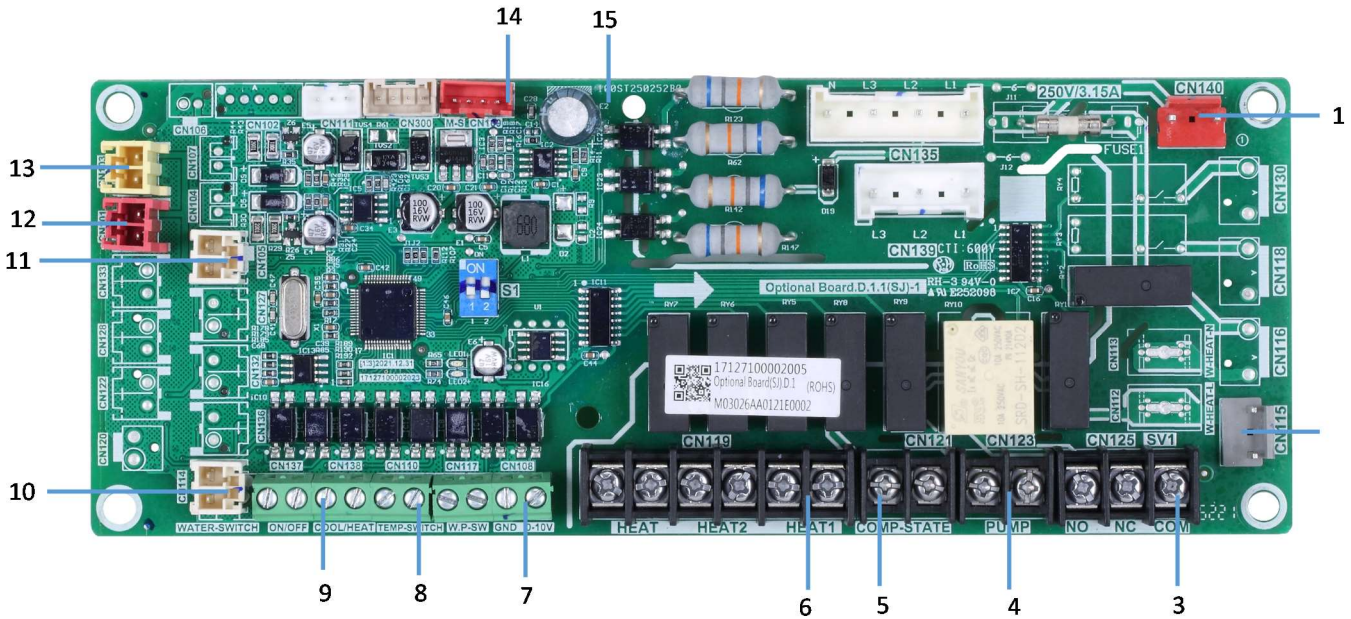

Label	Code	Port	Explanation	Voltage
1	CN140	POWER	Slave PCB board strong power supply	220-240V
2	CN115	W-HEAT	Water pipe electric heating belt	220-240V
3	CN125	3-way valve	Three-way valve for making hot water (used for customized hot water models)	220-240V
4	CN123	PUMP	Port for water pump contactor control (for market installation)	220-240V
5	CN121	COMP-STATE	Compressor Status Indication	/
6	CN119	HEAT1	Pipe auxiliary motor heating belt	/
7	CN108	PUMP-V	Frequency conversion pump 0-10V control signal	DC 0-10V
8	CN110	W.P-SW	Water pressure difference switch	DC12V
		TEMP-SW	Target water temperature switch	DC12V
9	CN138	COOL/HEAT	Remote mode control	DC12V
		ON/OFF	Remote switch control	DC12V
10	CN114	WATER-SWITCH	Water flow switch	DC12V
11	CN105	Taf1	Water tank anti-freeze sensor	DC3.3V
12	CN101	TW	Total water sensor	DC3.3V
13	CN103	T5	Water tank sensor	DC3.3V
14	CN300	DEBUG	Main control program burn port (WizPro200RS programmer)	DC3.3V
15	CN109	MS	Communication port of slave PCB board and main PCB board	DC12V/DC3.3V

3 Wiring diagram

3.1 Single unit

For SCV-750EB and SCV-1400EB

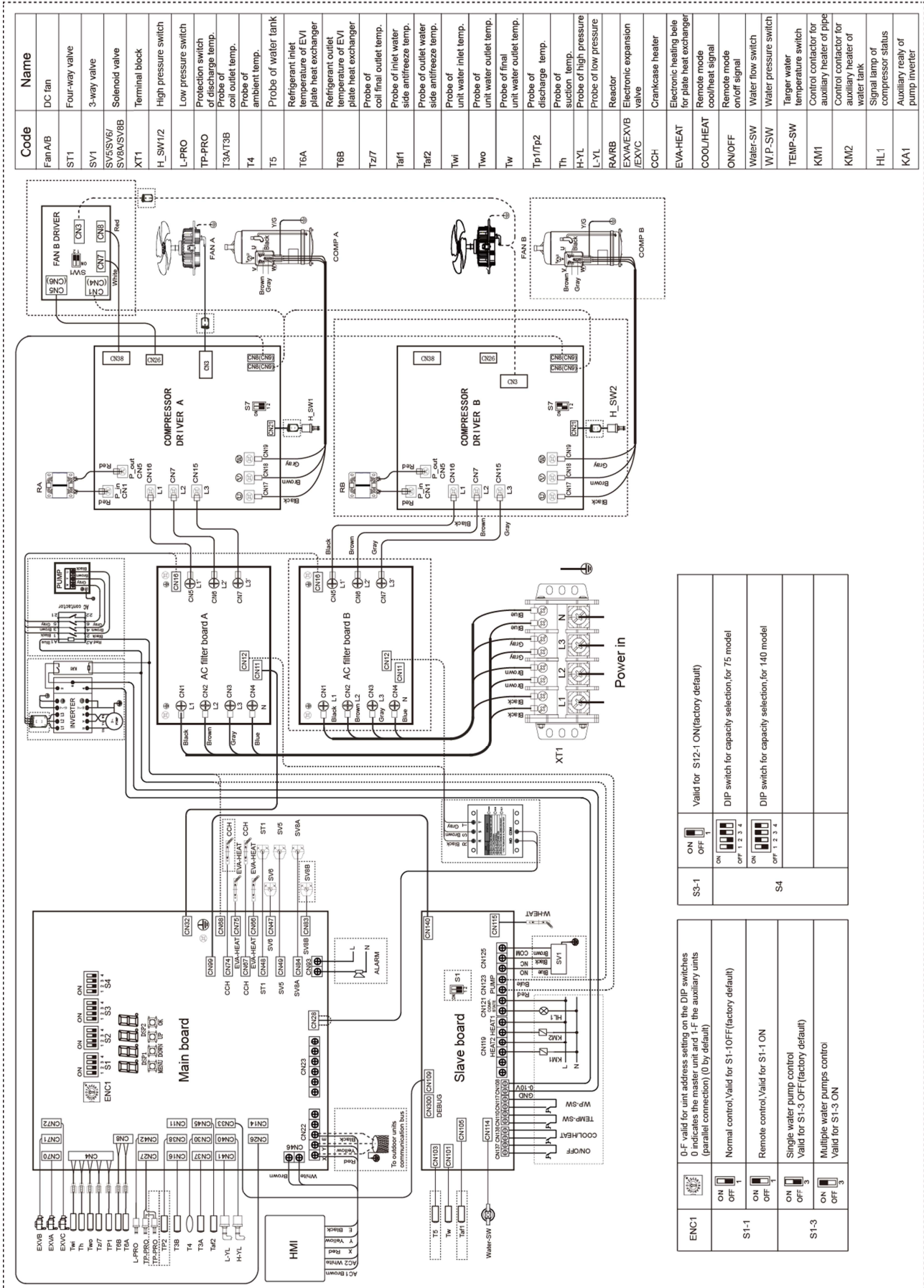

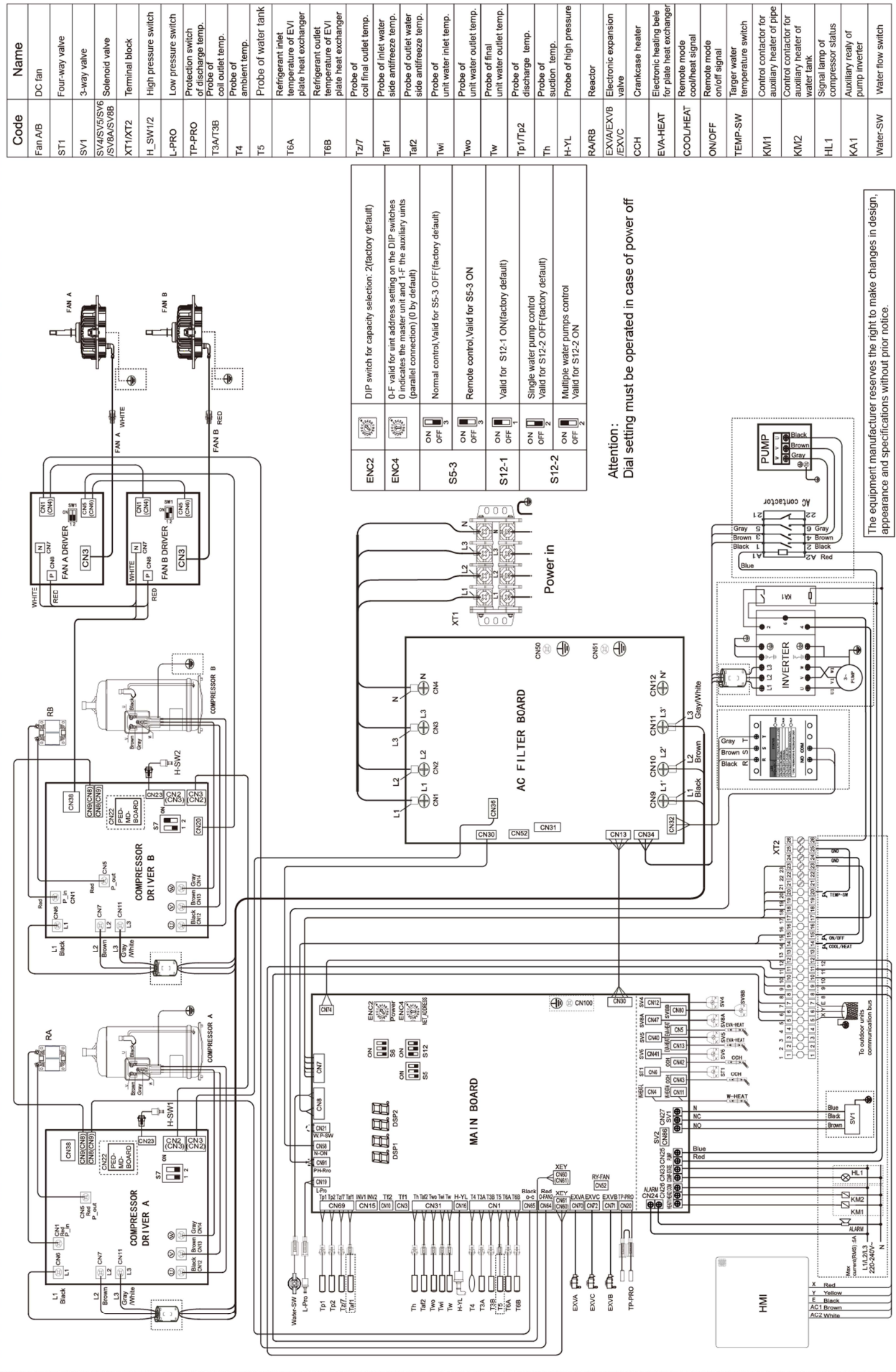

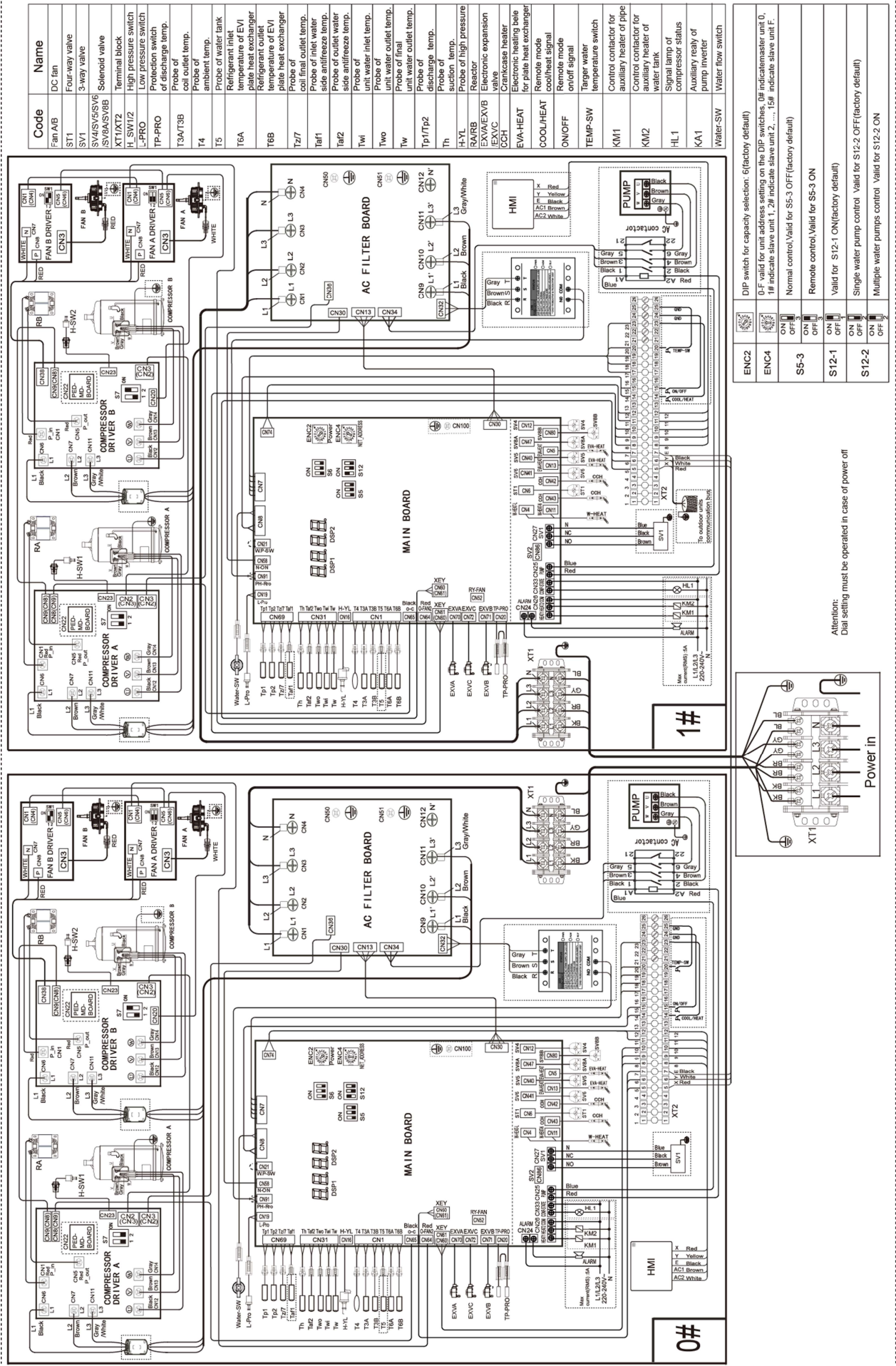

Attention: Dial setting must be operated in case of power off

3.2 Multiple units

For SCV-750EB:

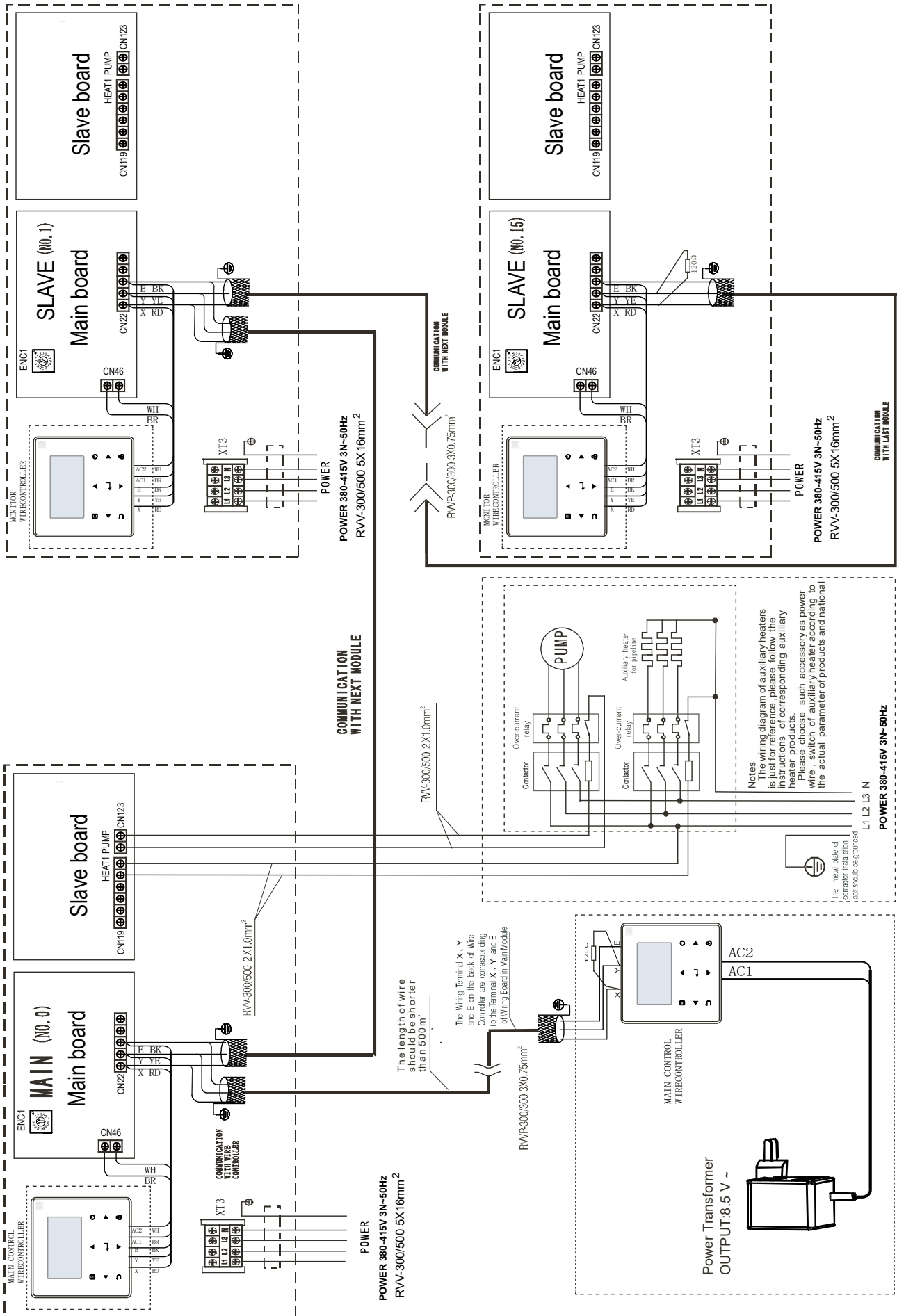

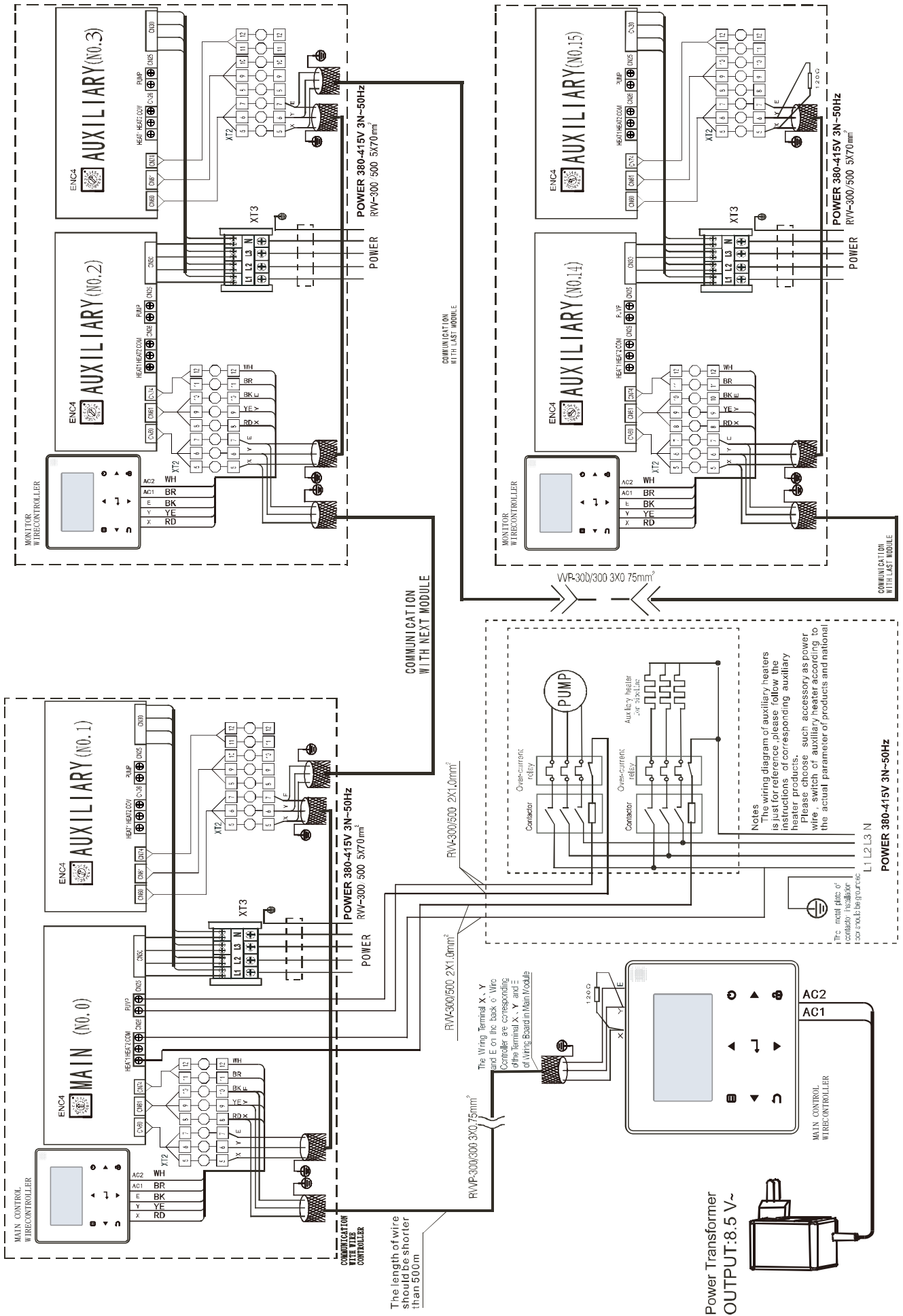

The length of wire should be shorter than 500m

Power Transformer
OUTPUT: 8.5 V~

4 Error Code Table

Code	Content	Remarks
E0	Main control EPROM error	Displayed on main PCB and user interface
E1	Phase sequence failure of main control board check	Displayed on main PCB and user interface
E2	Main control and wired control transmission error	Displayed on main PCB and user interface
	Communication failure between master and slave	
E3	Total water outlet temperature sensor error (valid for the main unit)	Displayed on main PCB and user interface
E4	Unit water outlet temperature sensor error	Displayed on main PCB and user interface
E5	1E5 Condenser tube temperature sensor T3A error	Displayed on main PCB and user interface
	2E5 Condenser tube temperature sensor T3B error	
E6	Water tank temperature sensor T5 error	Displayed on main PCB and user interface
E7	Ambient temperature sensor error	Displayed on main PCB and user interface
E8	Power supply phase sequence protector output error	Displayed on main PCB and user interface
E9	Water flow detection error	Displayed on main PCB and user interface
Eb	1Eb: Taf1 the pipe of the tank antifreeze protection sensor error	Displayed on main PCB and user interface
	2Eb: Taf2 cooling evaporator low-temperature antifreeze protection sensor error	Displayed on main PCB and user interface
EC	Slave unit module reduction	Displayed on main PCB and user interface
Ed	System discharge temperature sensor error	Displayed on main PCB and user interface
EE	1EE EVI plate heat exchanger refrigerant temperature T6A sensor error	Displayed on main PCB and user interface
	2EE EVI plate heat exchanger refrigerant temperature T6B sensor error	Displayed on main PCB and user interface
EF	Unit water return temperature sensor error	Displayed on main PCB and user interface
EH	System self-check error alarm (for SCV-900EB and SCV-1800EB)	Displayed on main PCB and user interface
EP	Discharge sensor error alarm	Displayed on main PCB and user interface
EU	Tz sensor error	Displayed on main PCB and user interface
P0	P0 System high-pressure protection or discharge temperature protection	Displayed on main PCB and user interface
	1P0 Compressor module 1 high pressure protection	Displayed on main PCB and user interface
	2P0 Compressor module 2 high pressure protection	Displayed on main PCB and user interface
P1	System low pressure protection	Displayed on main PCB and user interface
P2	Tz total cold outlet temperature too high (for SCV-900EB and SCV-1800EB)	Displayed on main PCB and user interface
P3	T4 ambient temperature too high in cooling mode	Displayed on main PCB and user interface
P4	1P4 System A current protection	Displayed on main PCB and user interface
	2P4 System A DC bus current protection	Displayed on main PCB and user interface
P5	1P5 System B current protection	Displayed on main PCB and user interface
	2P5 System B DC bus current protection	Displayed on main PCB and user interface
P6	Inverter module failure (for SCV-900EB and SCV-1800EB)	Displayed on main PCB and user interface
P7	High temperature protection of system condenser	Displayed on main PCB and user interface
P9	Water inlet and outlet temperature difference protection	Displayed on main PCB and user interface
PA	Abnormal water inlet and outlet temperature difference protection	Displayed on main PCB and user interface
Pb	Winter antifreeze protection	Displayed on main PCB and user interface
PC	Cooling evaporator pressure too low	Displayed on main PCB and user interface
PE	Cooling evaporator low temperature antifreeze protection	Displayed on main PCB and user interface
PH	Heating T4 too high temperature protection	Displayed on main PCB and user interface
PL	Tfin module too high temperature protection	Displayed on main PCB and user interface

Continued:

Code	Content	Remarks
PU	1PU DC fan A module protection	Displayed on main PCB and user interface
	2PU DC fan B module protection	Displayed on main PCB and user interface
H9	1H9 Compressor A inverter module is not matched	Displayed on main PCB and user interface
	2H9 Compressor A inverter module is not matched	Displayed on main PCB and user interface
HC	High pressure sensor error	Displayed on main PCB and user interface
HE	1HE No inset A valve error	Displayed on main PCB and user interface
	2HE No inset B valve error	Displayed on main PCB and user interface
	3HE No inset C valve error	Displayed on main PCB and user interface
F0	1FO IPM module A transmission error	Displayed on main PCB and user interface
	2FO IPM module B transmission error	Displayed on main PCB and user interface
F2	Superheat insufficient	Displayed on main PCB and user interface
F4	1F4 module A L0 or L1 protection occurs for 3 times in 60 minutes	Displayed on main PCB and user interface
	2F4 module B L0 or L1 protection occurs for 3 times in 60 minutes	Displayed on main PCB and user interface
F6	1F6 A system buss voltage error (PTC)	Displayed on main PCB and user interface
	2F6 B system buss voltage error (PTC)	Displayed on main PCB and user interface
Fb	Pressure sensor error	Displayed on main PCB and user interface
Fd	Suction temperature sensor error	Displayed on main PCB and user interface
FF	1FF DC fan A error	Displayed on main PCB and user interface
	2FF DC fan B error	Displayed on main PCB and user interface
FP	DIP switch inconsistency of multiple water pumps	Displayed on main PCB and user interface
C7	If PL occurs 3 times, the system reports the C7 failure	Displayed on main PCB and user interface
L0	Compressor inverter module protection (x=1or2) (for SCV-900EB and SCV-1800EB)	Displayed on main PCB
L1	Low-voltage protection (x=1or2) (for SCV-900EB and SCV-1800EB)	Displayed on main PCB
L2	High-voltage protection (x=1or2) (for SCV-900EB and SCV-1800EB)	Displayed on main PCB
L4	MCE error (x=1or2) (for SCV-900EB and SCV-1800EB)	Displayed on main PCB
L5	Zero speed protection (x=1or2) (for SCV-900EB and SCV-1800EB)	Displayed on main PCB
L7	Phase sequence error (x=1or2) (for SCV-900EB and SCV-1800EB)	Displayed on main PCB
L8	Compressor frequency variation greater than 15Hz within one second protection (for SCV-900EB and SCV-1800EB)	Displayed on main PCB
L9	Actual compressor frequency differs from target frequency by more than 15Hz protection (for SCV-900EB and SCV-1800EB)	Displayed on main PCB
dF	Defrosting prompt (for SCV-900EB and SCV-1800EB)	Displayed on main PCB and user interface
bH	1bH Module 1 relay blocking or 908 chip self-check failed	Displayed on main PCB and user interface
	2bH Module 2 relay blocking or 908 chip self-check failed	Displayed on main PCB and user interface

5 Troubleshooting

5.1 Warning

Warning



- All electrical work must be carried out by competent and suitably qualified, certified and accredited professionals and in accordance with all applicable legislation (all national, local and other laws, standards, codes, rules, regulations and other legislation that apply in a given situation).
- Power-off the outdoor units before connecting or disconnecting any connections or wiring, otherwise electric shock (which can cause physical injury or death) may occur or damage to components may occur.

5.2 E0/H9 Troubleshooting

5.2.1 Digital display output



5.2.2 Description

For SCV-750EB and SCV-1400EB

- E0 indicates that the capability dialing code of the main PCB is inconsistent with the actual model.
- 1H9 indicates that the driving model of IPM inverter module (compressor A) does not match.
- 2H9 indicates that the driving model of IPM inverter module (compressor B) does not match.
- All units stop running.
- Error code is displayed on main PCB and user interface...d user interface.

For SCV-900EB and SCV-1800EB

- E0 indicates main PCB EEPROM error.
- 1H9 indicates IPM inverter module (compressor A) EEPROM error.
- 2H9 indicates IPM inverter module (compressor B) EEPROM error.
- All units stop running.
- Error code is displayed on main PCB and user interface...d user interface.

5.2.3 Possible causes

For SCV-750EB and SCV-1400EB

- The dialing code of main PCB capability is error.
- The address dialing code of the IPM inverter module PCB is error.
- Main PCB or IPM inverter module damaged.

For SCV-900EB and SCV-1800EB

- Main PCB or IPM inverter module EEPROM is not connected properly.
- Main PCB or IPM inverter module damaged.
- EEPROM damaged.

5.2.4 Procedure

For SCV-750EB and SCV-1400EB

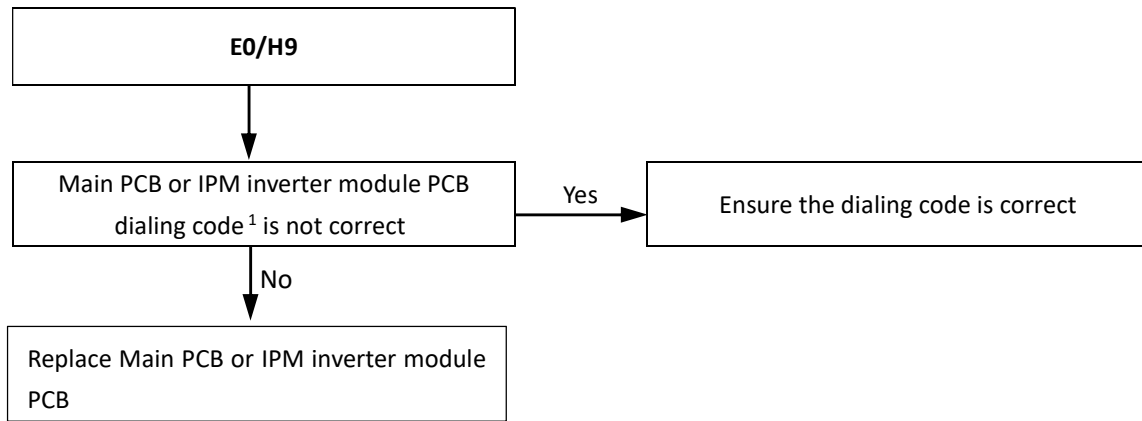

Notes:

1. Main PCB capability dialing code is designated S4 on the main PCBs (labeled 39 in Part 4, 2.2.1 Main PCB component);
2. Compressor inverter module PCB address dialing code is designated S7 on compressor inverter module PCB.

For SCV-900EB and SCV-1800EB

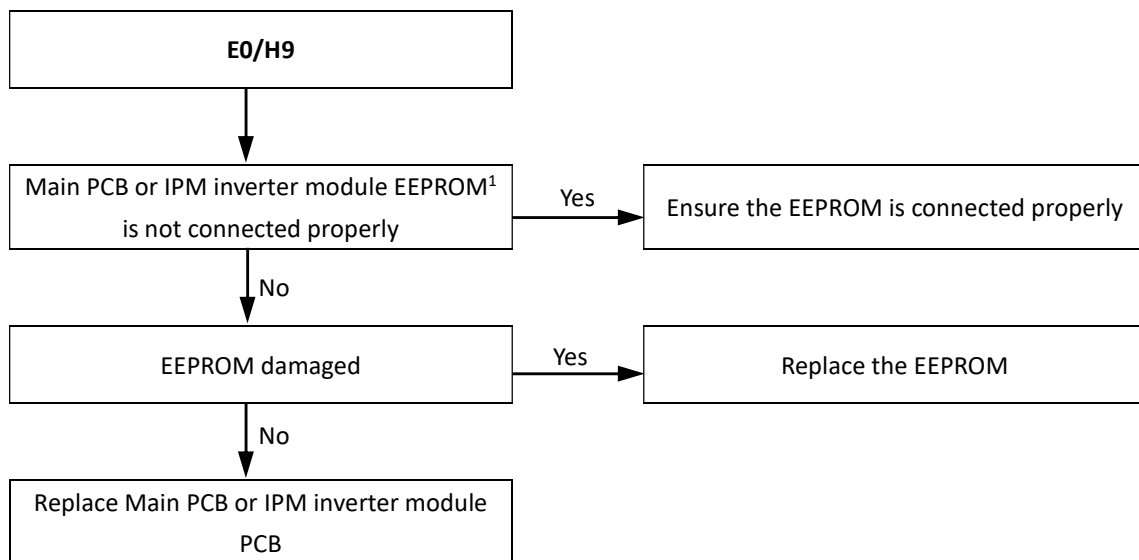

Notes:

1. Main PCB EEPROM is designated IC10 on the main PCBs (labeled 28 in Part 4, 2.2.1 Main PCB component);
2. Compressor inverter module PCB EEPROM is designated IC25 on compressor inverter module PCB (labeled 18 in Part 4, 2.3.1 Compressor Inverter Module PCB component).

5.3 E1 Troubleshooting

5.3.1 Digital display output



5.3.2 Description

- Phase sequence error.
- Unit stops running.
- Error code is displayed on main PCB and user interface.

5.3.3 Possible causes

- Power supply phases not connected in correct sequence.
- Power supply terminals loose.
- Power supply abnormal.
- Main PCB damaged.

5.3.4 Procedure

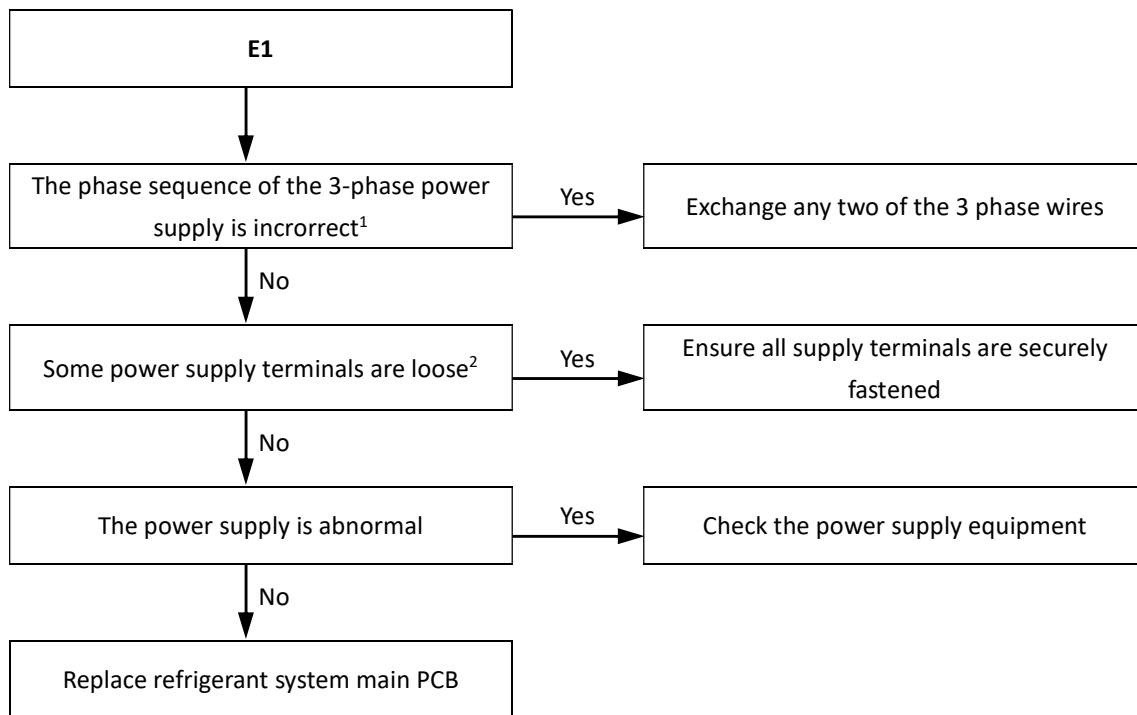

Notes:

1. The A, B, C terminals of 3-phase power supply should match compressor phase sequence requirements. If the phase sequence is inverted, the compressor will operate inversely. If the wiring connection of each outdoor unit is in A, B, C phase sequence, and multiple units are connected, the current difference between C phase and A, B phases will be very large as the power supply load of each outdoor unit will be on C phase. This can easily lead to tripped circuits and terminal wiring burnout. Therefore if multiple units are to be used, the phase sequence should be staggered, so that the current is distributed among the three phases equally.

2. Loose power supply terminals can cause the compressor to operate abnormally and compressor current to be very large.

5.4 E2 Troubleshooting

5.4.1 Digital display output



5.4.2 Description

- Communication error between outdoor unit and user interface.
- Communication failure between master and slave units
- All units stop running.
- Error code is displayed on main PCB and user interface.

5.4.3 Possible causes

- Communication wires between outdoor unit and user interface not connected properly.
- For SCV-900EB, Communication wiring P Q E terminals misconnected. For SCV-750EB, SCV-1400EB SCV-1800EB, Communication wiring X Y E terminals misconnected
- Wiring connection is loosen
- Interference from high voltage wires or other sources of electromagnetic radiation.
- Communication wire too long.
- Damaged main PCB, user interface or electric control box communication terminals block.

5.4.4 Procedure

For SCV-900EB:

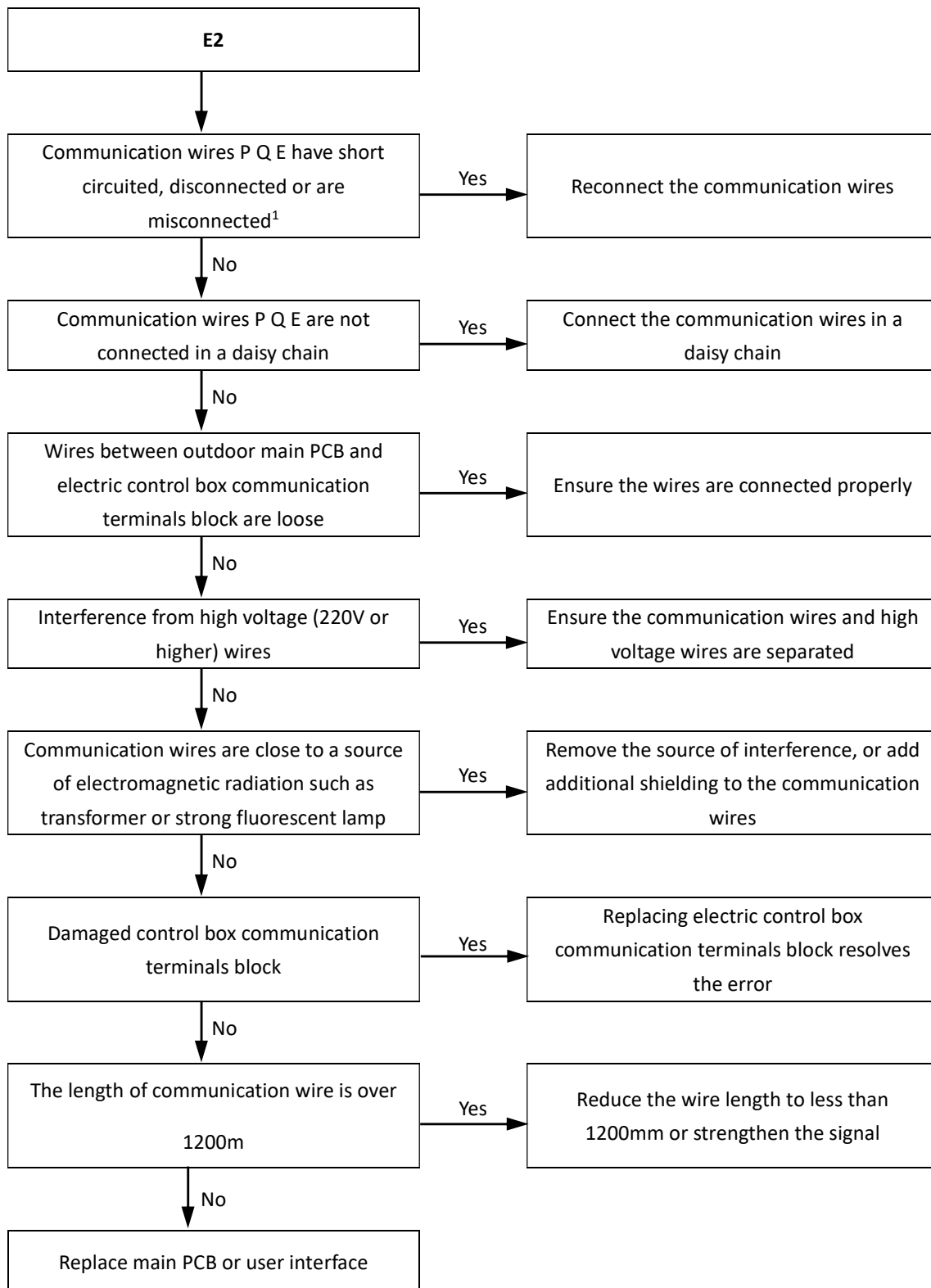

Notes:

1. Measure the resistance among P, Q and E. The normal resistance between P and Q is 120Ω, between P and E is infinite, between Q and E is infinite. Communication wiring has polarity. Ensure that the P wire is connected to P terminals and the Q wire is connected to Q terminals.

For SCV-750EB, SCV-1400EB and SCV-1800EB:

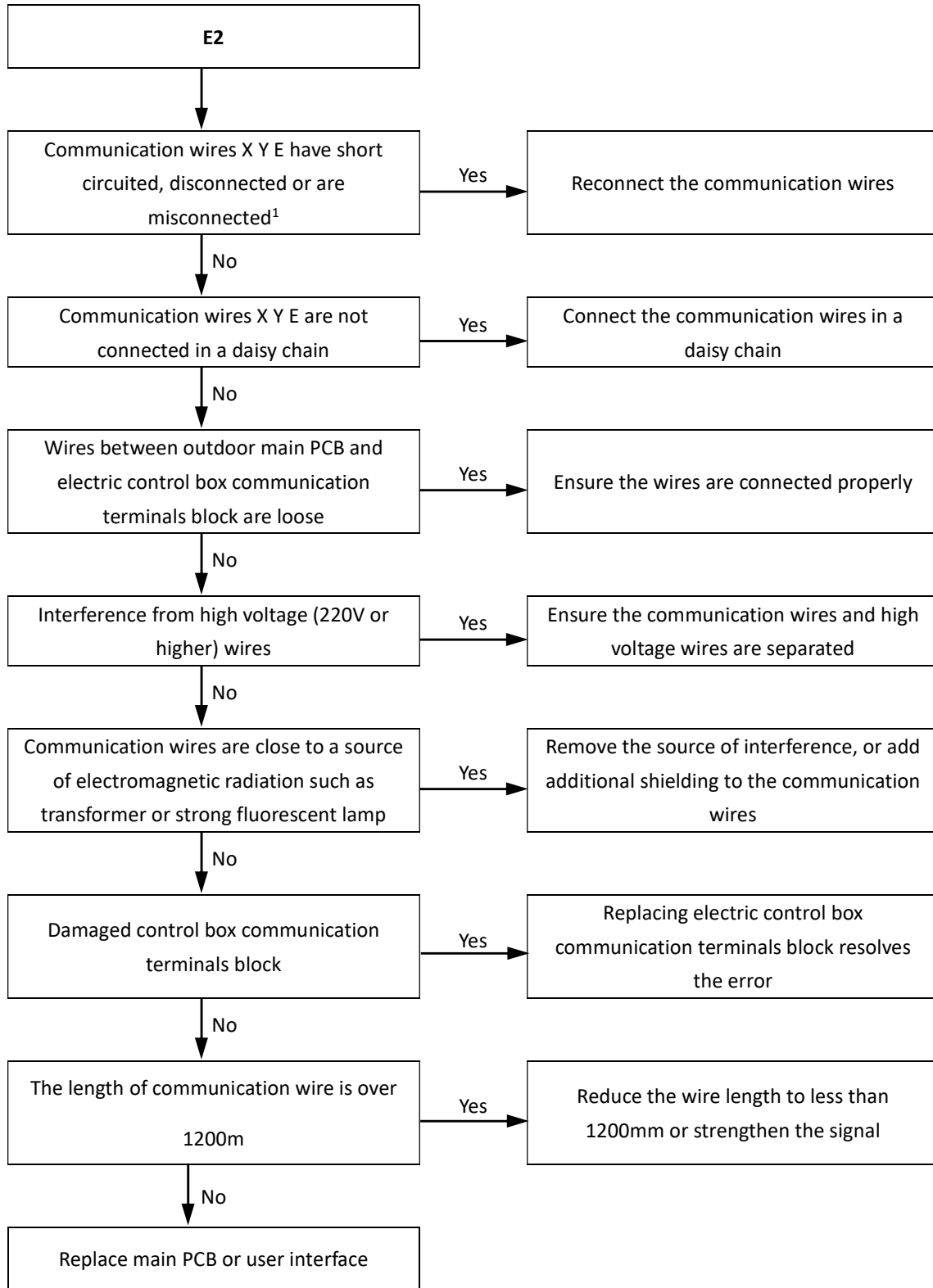

Notes:

1. Measure the resistance among X, Y and E. The normal resistance between X and Y is 120Ω, between X and E is infinite, between Y and E is infinite. Communication wiring has polarity. Ensure that the P wire is connected to P terminals and the Q wire is connected to Q terminals.
2. Check whether the communication wires X, Y and E between units have disconnected or are misconnected.

5.5 E3, E4, E5, E7, Eb, Ed, EE, EF, EP, EU, Fb, Fd Troubleshooting

5.5.1 Digital display output

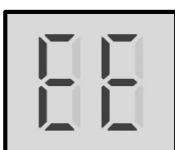
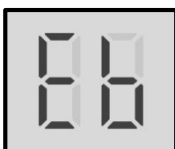



5.5.2 Description

For SCV-750EB and SCV-1400EB

- E3 indicates total water outlet temperature sensor error (valid for the main unit)
- E4 unit water outlet temperature sensor error
- 1E5 indicates condenser tube temperature sensor T3A error
- 2E5 indicates condenser tube temperature sensor T3B error
- E6 Water tank temperature sensor T5 failure
- E7 indicates ambient temperature sensor error
- 1Eb indicates pipe of the tank antifreeze protection sensor Taf1 error
- 2Eb indicates cooling evaporator low-temperature antifreeze protection sensor Taf2 error
- Ed indicates discharge pipe temperature sensors Tp1 and Tp2 error at the same time
- 1EE indicates EVI plate heat exchanger refrigerant temperature sensor T6A error
- 2EE indicates EVI plate heat exchanger refrigerant temperature sensor T6B error
- EF indicates unit water return temperature sensor error
- EP indicates discharge temperature sensor failure error
- EU indicates water side heat exchanger refrigerant total outlet temperature sensor Tz error in heating mode.
- Fb indicates Low pressure sensor error.
- Fd indicates suction temperature sensor Th error.
- All stop running.
- Error code is displayed on main PCB and user interface.

For SCV-900EB and SCV-1800EB

- E3 indicates total water outlet temperature sensor error (valid for the main unit)
- E4 unit water outlet temperature sensor error
- 1E5 indicates condenser tube temperature sensor T3A error
- 2E5 indicates condenser tube temperature sensor T3B error
- E7 indicates ambient temperature sensor error
- 1Eb indicates pipe of the tank antifreeze protection sensor Taf1 error
- 2Eb indicates cooling evaporator low-temperature antifreeze protection sensor Taf2 error

- Ed indicates discharge pipe temperature sensors Tp1 and Tp2A error at the same time
- 1EE indicates EVI plate heat exchanger refrigerant temperature sensor T6A error
- 2EE indicates EVI plate heat exchanger refrigerant temperature sensor T6B error
- EF indicates unit water return temperature sensor error
- EP indicates discharge temperature sensor failure error
- EU indicates air side heat exchanger refrigerant total outlet temperature sensor Tz error.
- Fb indicates pressure sensor error.
- Fd indicates suction temperature sensor Th error.
- All stop running.
- Error code is displayed on main PCB and user interface.

5.5.3 Possible causes

- Sensor not connected properly or has malfunctioned.
- Damaged main PCB.

5.5.4 Procedure

For SCV-750EB and SCV-1400EB

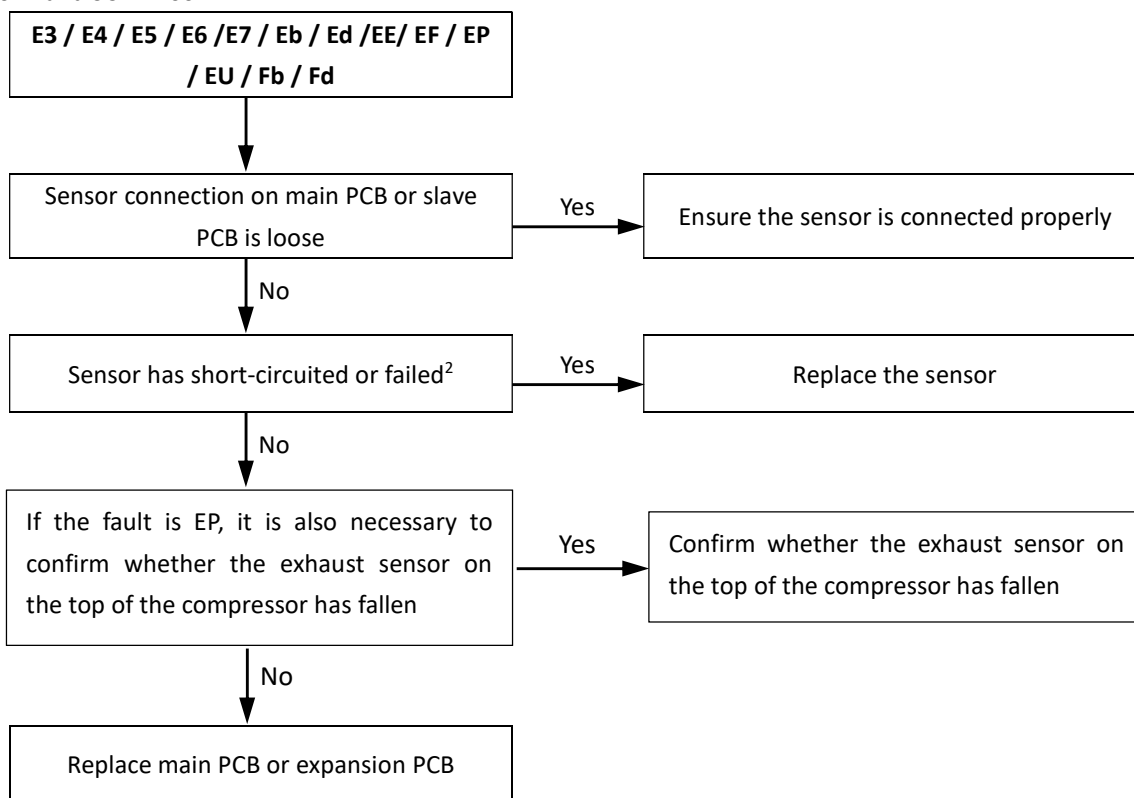

Notes:

1. Most sensors are connected to ports CN4 (E4), CN37 (1E5), CN16 (2E5), CN30 (E7), CN45 (2Eb), CN4 and CN38 (Ed), CN8 (EE), CN4 (EF), CN4 and CN38 (EP), CN4 (EU), CN41 (Fb), CN4 (Fd) on the main PCB (labeled 29, 22, 24, 23, 21, 25, 28, 19 in Part 4, 2.2.1 Main PCB component), A few sensors are connected to ports CN101 (E3), CN103 (E6), CN105 (1Eb) on the slave PCB (labeled 14,15,13 in Part 4, 2.7 Slave PCB component).

2. Measure sensor resistance. If the resistance is too low, the sensor has short-circuited. If the resistance is not consistent with the sensor's resistance characteristics table, the sensor has failed. Refer to Part 4, 6.1 "Temperature Sensor Resistance Characteristics".

For SCV-900EB and SCV-1800EB

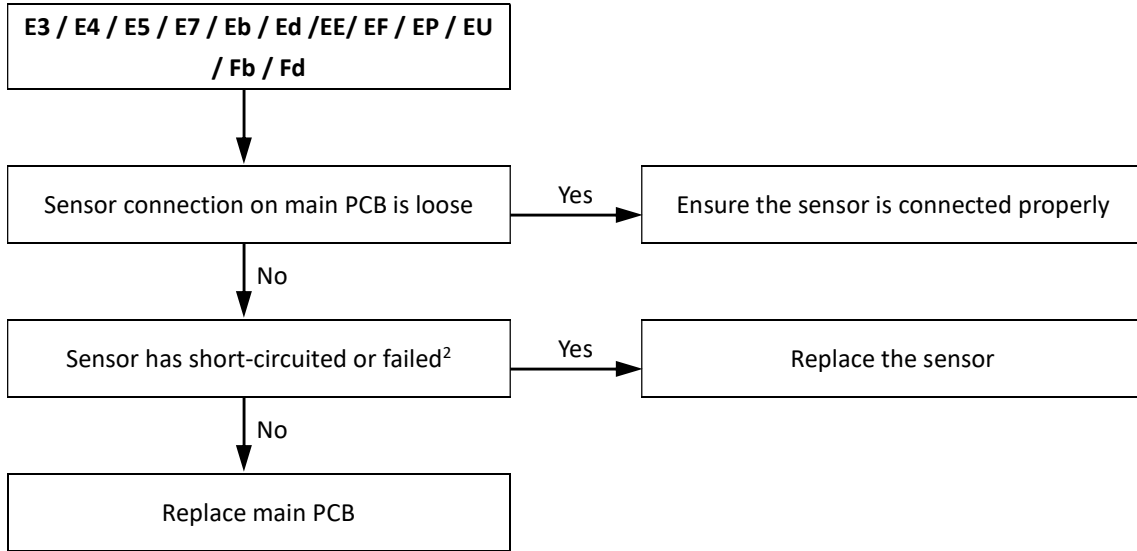

Notes:

1. All the sensors are connected to port CN1, CN16, CN31, CN3, CN10 and CN69 on the main PCB (labeled 29, 30, 31, 32 in Part 4, 2.2.1 Main PCB component).
2. Measure sensor resistance. If the resistance is too low, the sensor has short-circuited. If the resistance is not consistent with the sensor's resistance characteristics table, the sensor has failed. Refer to Part 4, 6.1 "Temperature Sensor Resistance Characteristics".

5.6 E8 Troubleshooting

5.6.1 Digital display output



5.6.2 Description

- Power supply phase sequence protector output error
- When this error occurs in the main unit, all units stop running. When this error occurs in the slave unit, the slave unit stops running.
- Error code is displayed on main PCB and user interface.

5.6.3 Possible causes

- Power supply phases not connected in correct sequence or lose.
- Power supply terminals or Power phase protector wire connection loose.
- Power supply abnormal.
- Damaged main PCB.
- Damaged power phase protector.

5.6.4 Procedure

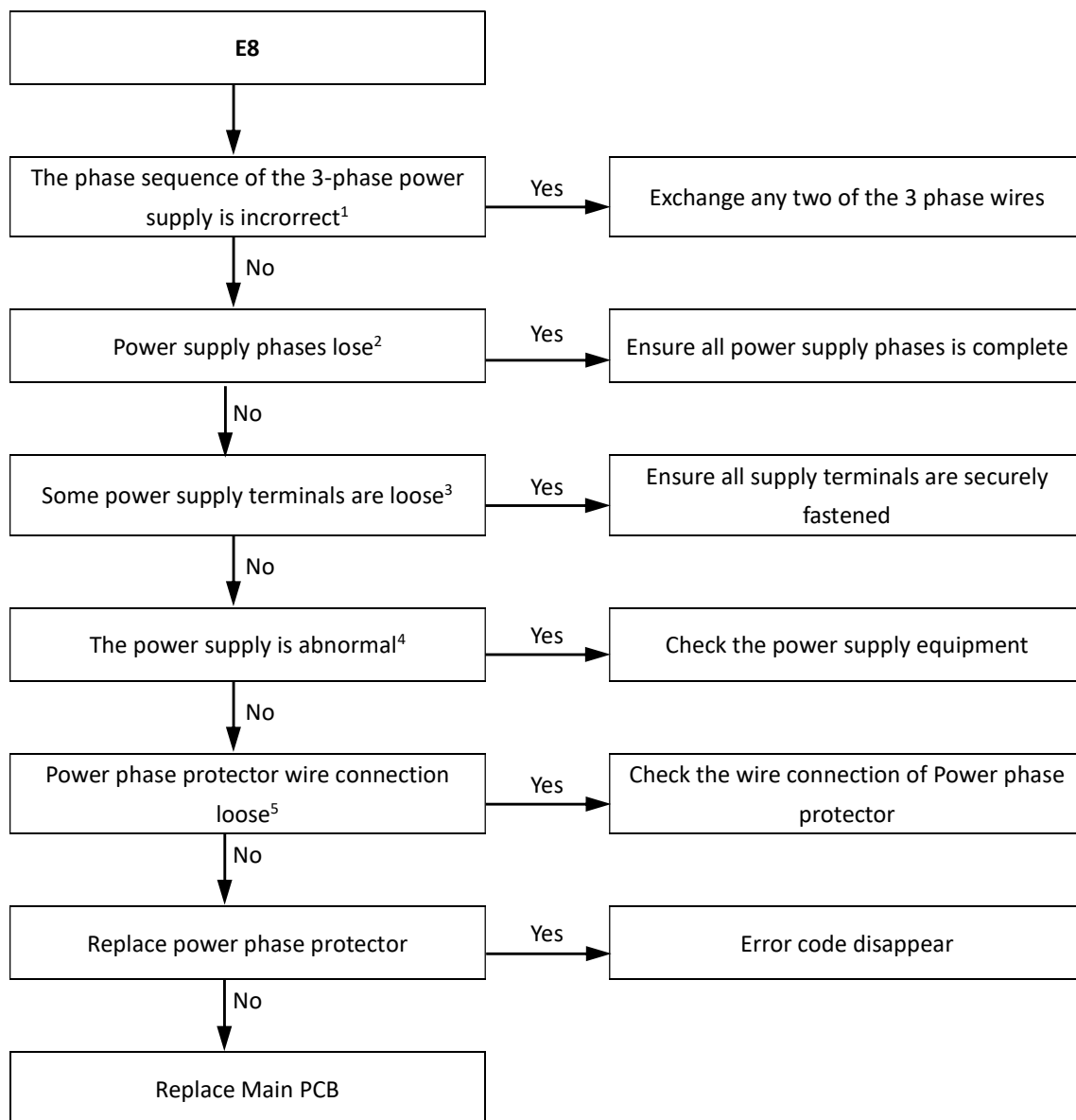

Notes:

1. The red LED on the power phase protector will on.
2. The red LED on the power phase protector will flash with 1HZ.
3. The A, B, C terminals of 3-phase power supply should match compressor phase sequence requirements. If the phase sequence is inverted, the compressor will operate inversely. If the wiring connection of each outdoor unit is in A, B, C phase sequence, and multiple units are connected, the current difference between C phase and A, B phases will be very large as the power supply load of each outdoor unit will be on C phase. This can easily lead to tripped circuits and terminal wiring burnout. Therefore if multiple units are to be used, the phase sequence should be staggered, so that the current is distributed among the three phases equally.
4. The red LED on the power phase protector will flash with 3HZ. Loose power supply terminals can cause the compressor to operate abnormally and compressor current to be very large.
5. For SCV-750EB and SCV-1400EB, wire connected to port CN28 on the main PCB. For SCV-900EB and SCV-1800EB, wire connected to port CN91 on the main PCB. (labeled 34 in Part 4, 2.2.1 Main PCB component)

5.7 E9 Troubleshooting

5.7.1 Digital display output



5.7.2 Description

- Water flow failure.
- E9 indicates water flow switch error. When E9 error occurs 3 times in 60 minutes, manual system restart is required before the system can resume operation.
- All units stop running.
- Error code is displayed on main PCB and user interface.

5.7.3 Possible causes

- The wire circuit is short connected or open.
- Water flow rate is too low.
- Water flow switch damaged.
- Damaged main PCB.

5.7.4 Procedure

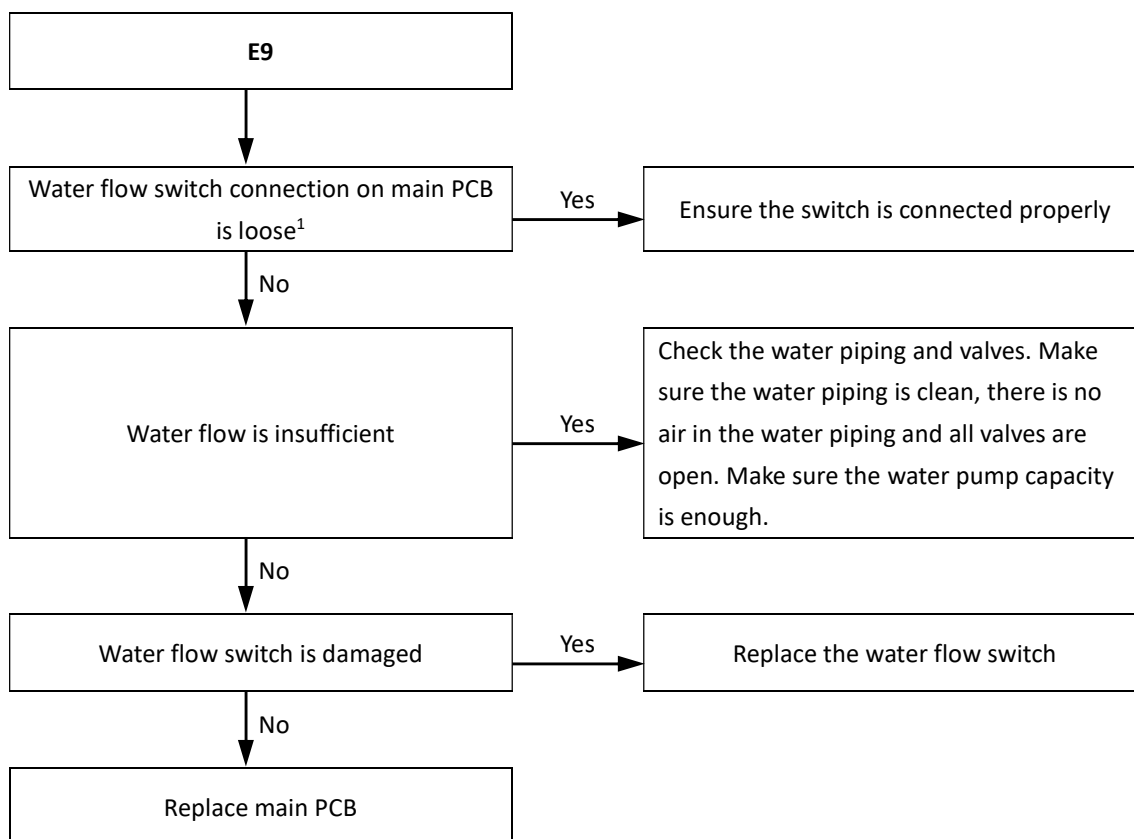

Notes:

1. For SCV-750EB and SCV-1400EB, Water flow switch connection is port CN114 on the slave PCB (labeled 12 in Part 4, 2.7 Slave PCB component).
2. For SCV-900EB and SCV-1800EB, Water flow switch connection is port CN8 on the main PCB (labeled 38 in Part 4, 2.2.1 Main PCB component).

5.8 EC Troubleshooting

5.8.1 Digital display output



5.8.2 Description

- EC indicates that the number of slave units detected by master unit has decreased.
- All units stop running.
- Error code is only displayed on the user interface.

5.8.3 Possible causes

- Some outdoor units power off.
- Power supply abnormal.
- Incorrect outdoor unit address setting.
- Communication wires between outdoor units not connected properly.
- Wiring connection is loosen.
- Damaged main PCB or electric control box communication terminals block.

5.8.4 Procedure

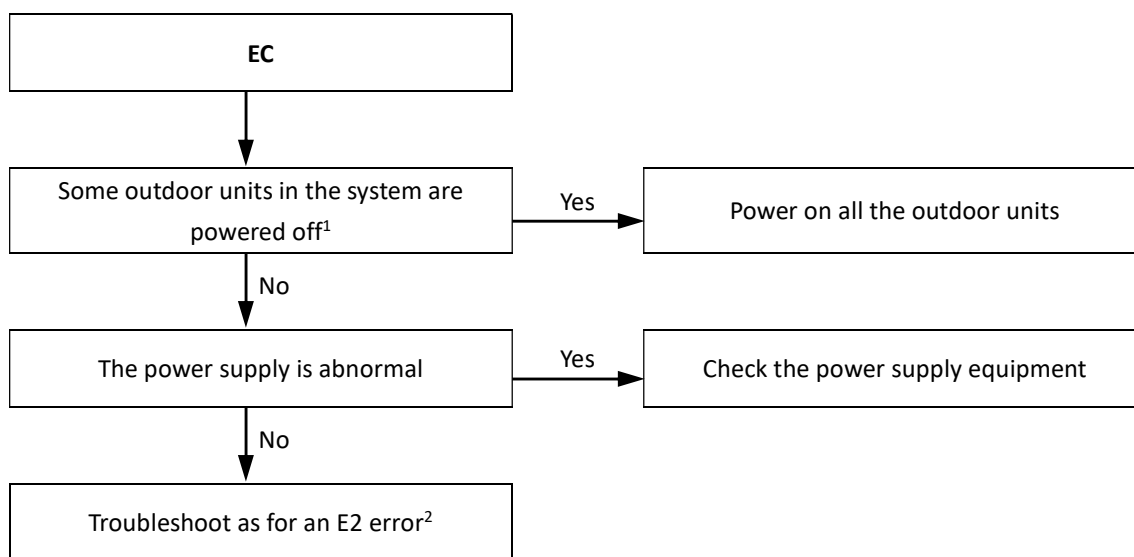

Notes:

1. For SCV-750EB and SCV-1400EB, check digital display on the main PCB. If digital display is on, the main PCB is powered on, if digital display is off, the main PCB is powered off. Please refer to labeled 11 in Part 4, 2.7 Slave PCB component.
2. For SCV-900EB and SCV-1800EB, check digital display on the main PCB. If digital display is on, the main PCB is powered on, if digital display is off, the main PCB is powered off. Please refer to labeled 37 in Part 4, 2.2.1 Main PCB component.
3. See Part 4, 4.4 "E2 Troubleshooting".

5.9 EH Troubleshooting (for SCV-900EB and SCV-1800EB only)

5.9.1 Digital display output



5.9.2 Description

- EH indicates system self-check in the factory, it will not display in the normal operating.

5.10 P0 Troubleshooting

5.10.1 Digital display output

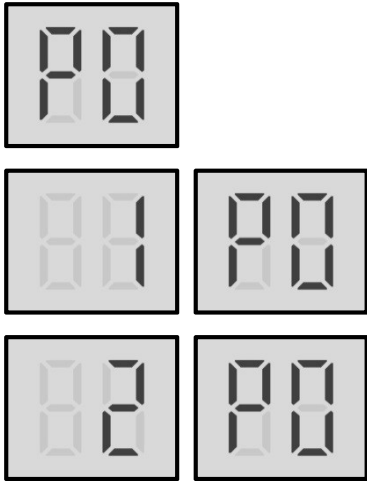

5.10.2 Description

- Discharge pipe high pressure or discharge temperature switch protection. When the discharge pressure rises above 4.2MPa or discharge temperature rises above 115°C, the system displays P0 protection and all units stop running. When the discharge pressure falls below 3.2MPa or discharge temperature fall below 90°C, P0 is removed and normal operation resumes. When P0 error occurs 3 times in 60 minutes, a manual system restart is required before the system can resume operation.
- Error code is displayed on main PCB and user interface.

5.10.3 Possible causes

- High pressure switch or discharge temperature switch not connected properly or has malfunctioned.
- Excess refrigerant.
- System contains air or nitrogen.
- High pressure side blockage.
- Poor condenser heat exchange.
- Main PCB damaged.

5.10.4 Procedure

For SCV-750EB and SCV-1400EB

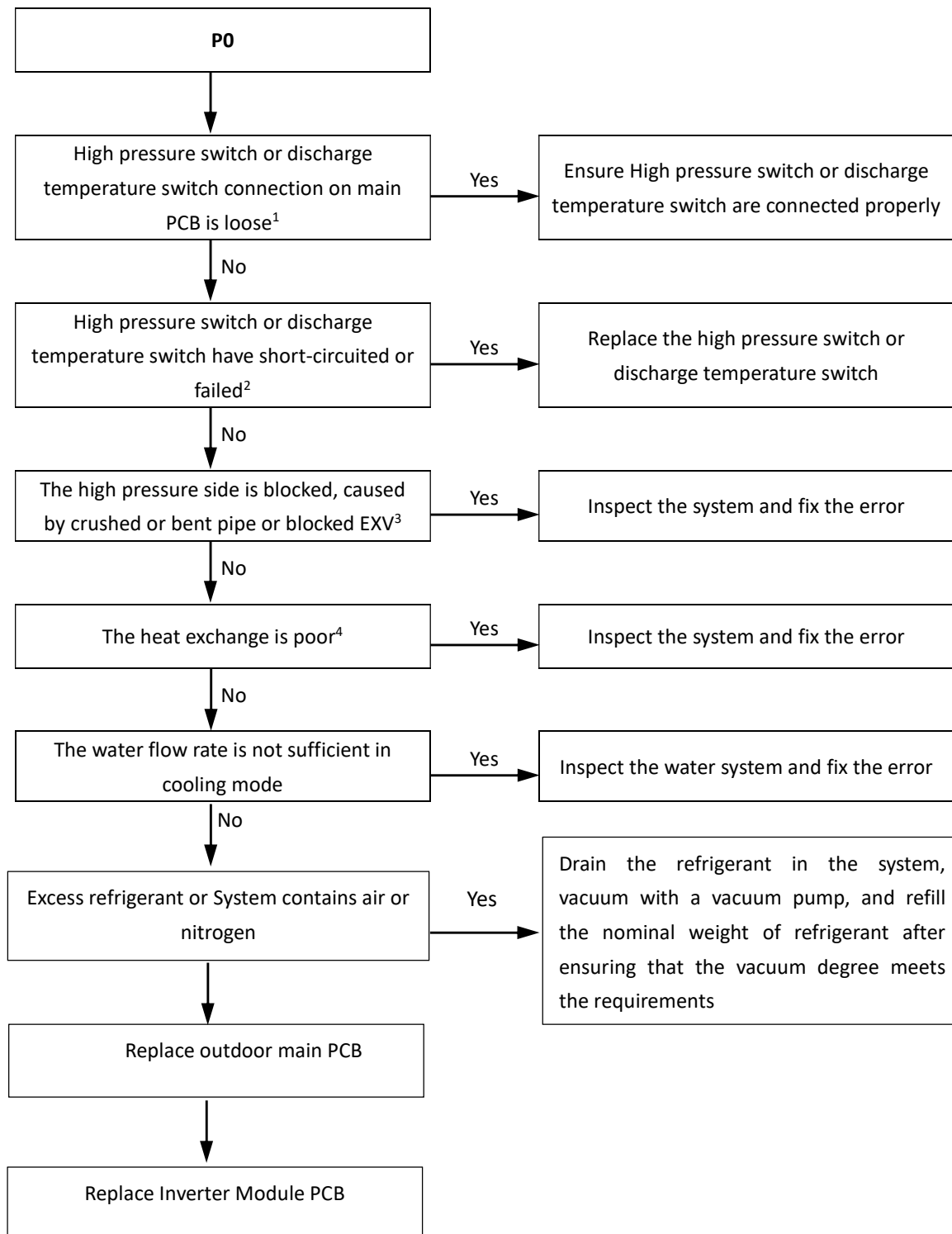

Notes:

1. Discharge temperature switch connection is port CN27 on the main PCB(labeled 26 in Part 4, 2.2.1 Main PCB component) .High pressure switch connection is port CN21 on the IPM inverter module PCB;
2. Measure the resistance among the three terminals of the pressure sensor. If the resistance is of the order of mega Ohms or infinite, the pressure sensor has failed;
3. High pressure side blockage causes discharge temperature to be higher than normal, discharge pressure to be higher than normal and suction pressure to be lower than normal;
4. In heating mode check water side heat exchanger, water piping, circulator pumps and water flow switch for dirt/blockages. In cooling mode check air side heat exchanger, fan(s) and air outlets for dirt/blockages.

For SCV-900EB and SCV-1800EB

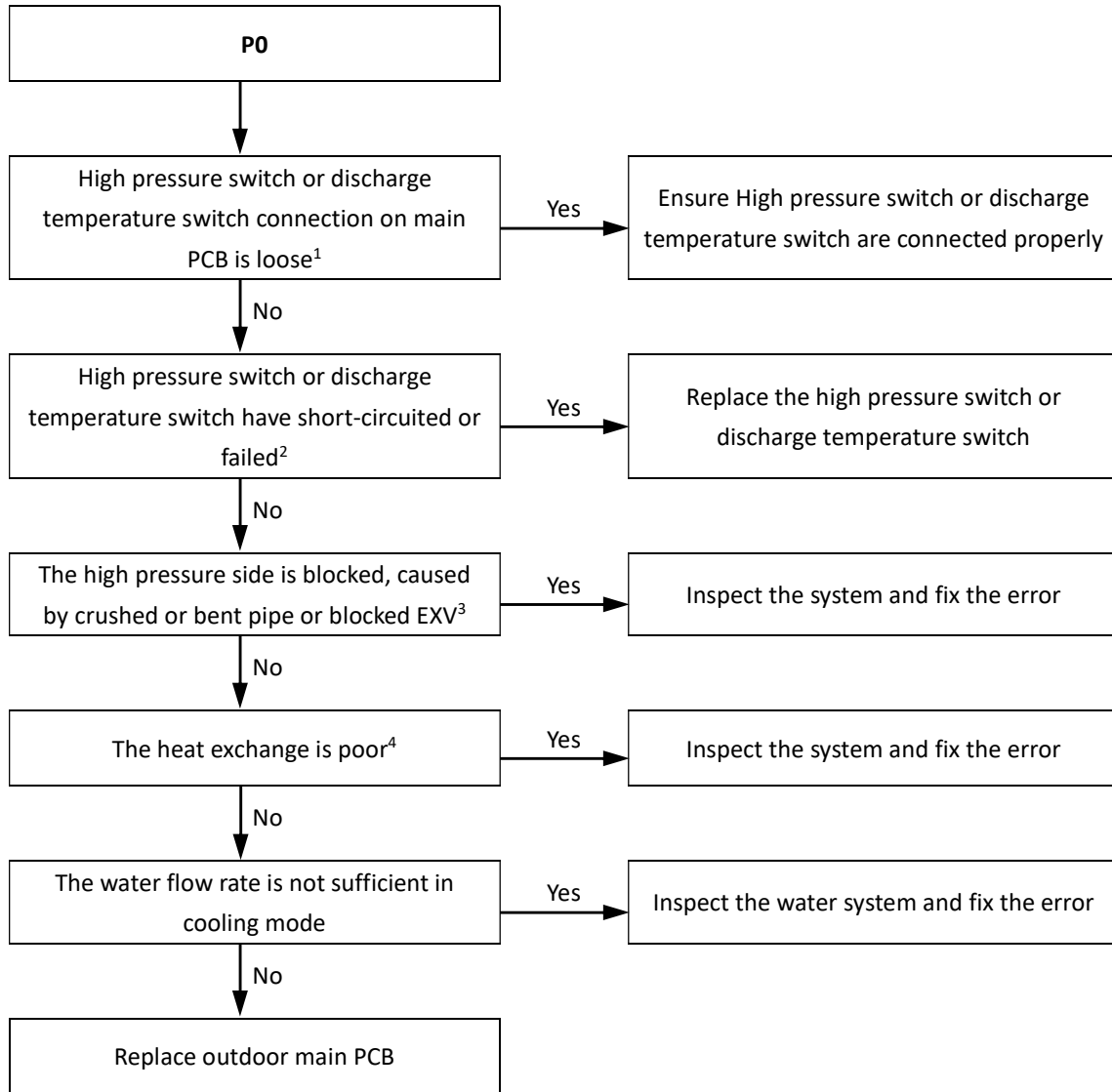

Notes:

1. High pressure switch connection is port CN20 on the main PCB (labeled 19 in Part 4, 2.2.1 Main PCB component).
2. Measure the resistance among the three terminals of the pressure sensor. If the resistance is of the order of mega Ohms or infinite, the pressure sensor has failed.
3. High pressure side blockage causes discharge temperature to be higher than normal, discharge pressure to be higher than normal and suction pressure to be lower than normal.
4. In heating mode check water side heat exchanger, water piping, circulator pumps and water flow switch for dirt/blockages. In cooling mode check air side heat exchanger, fan(s) and air outlets for dirt/blockages.

5.11 P1 Troubleshooting

5.11.1 Digital display output



5.11.2 Description

For SCV-750EB and SCV-1400EB

- P1 indicates suction pipe low pressure protection. When the suction pressure falls below 0.05MPa, the system displays P1 protection and all units stop running. When the pressure rises above 0.15MPa, P1 is removed and normal operation resumes. When P1 error occurs 3 times in 60 minutes, a manual system restart is required before the system can resume operation.
- P1 another indicates in the standby state or shutdown state, after the compressor stops for 3min, it is determined that the refrigerant quantity of the refrigerant system of the unit is insufficient through the saturation temperature corresponding to the high-pressure pressure, the system displays P1 protection, the unit does not start and the protection is not locked; When the detection pressure returns to above the judgment value, the protection is released and the unit can resume startup.
- P1 the last one indicates during the operation of the compressor of the unit, if the exhaust superheat is too high and lasts for 30min, report P1 protection first, and then judge the low refrigerant. If the low refrigerant protection is not triggered, P1 protection is removed and the operation is restarted according to the demand.
- Error code is displayed on main PCB and user interface.

For SCV-900EB and SCV-1800EB

- P1 indicates suction pipe low pressure protection. When the suction pressure falls below 0.05MPa, the system displays P1 protection and all units stop running. When the pressure rises above 0.15MPa, P1 is removed and normal operation resumes. When P1 error occurs 3 times in 60 minutes, a manual system restart is required before the system can resume operation.
- Error code is displayed on main PCB and user interface.

5.11.3 Possible causes

- Low pressure switch not connected properly or has malfunctioned.
- Insufficient refrigerant.
- Low pressure side blockage.
- Poor evaporator heat exchange in heating mode.
- Insufficient water flow in cooling mode.
- Main PCB damaged.

5.11.4 Procedure

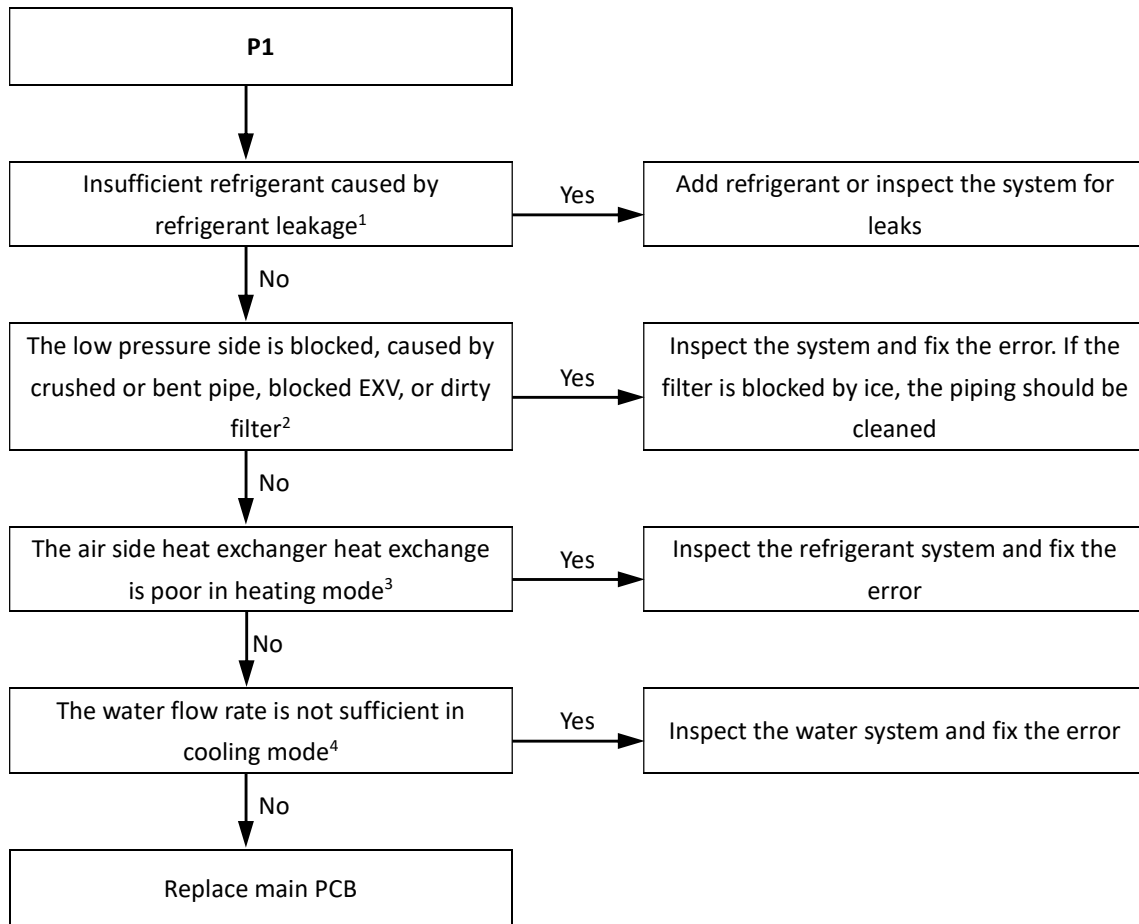

Notes: ☐

1. To check for insufficient refrigerant: An insufficiency of refrigerant causes compressor discharge temperature to be higher than normal, discharge and suction pressures to be lower than normal and compressor current to be lower than normal, and may cause frosting to occur on the suction pipe. These issues disappear once sufficient refrigerant has been charged into the system.
2. A low pressure side blockage causes compressor discharge temperature to be higher than normal, suction pressure to be lower than normal and compressor current to be lower than normal, and may cause frosting to occur on the suction pipe. For normal system parameters.
3. Check air side heat exchanger, fan(s) and air outlets for dirt/blockages.
4. Check water side heat exchanger, water piping, circulator pumps and water flow switch for dirt/blockages.

5.12 P4, P5 Troubleshooting

5.12.1 Digital display output

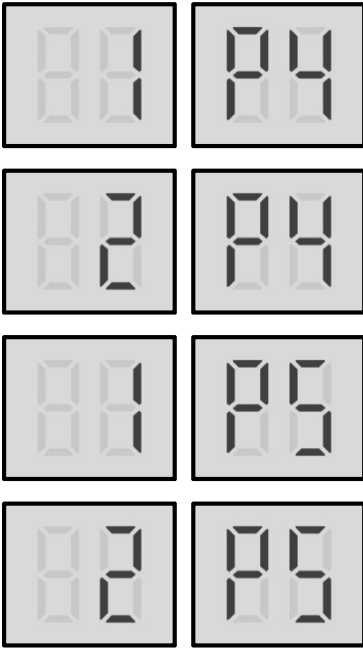

5.12.2 Description

- 1 P4 indicates system A current protection
- 2 P4 indicates system A DC bus current protection
- 1 P5 indicates system B current protection
- 2 P5 indicates system B DC bus current protection
- When the compressor current rises above the protection value 33A, the system displays P4 or P5 protection and all units stop running. When the current returns to the normal range, P4 or P5 is removed and normal operation resumes. When P4 or P5 error occurs 3 times in 60 minutes, a manual system restart is required before the system can resume operation.
- Error code is displayed on main PCB and user interface.

5.12.3 Possible causes

- Power supply abnormal.
- Poor condenser heat exchange.
- High pressure side blockage.
- Excess refrigerant.
- System contains air or nitrogen.
- Inverter module damaged.
- Compressor damaged.
- Main PCB damaged.

5.12.4 Procedure

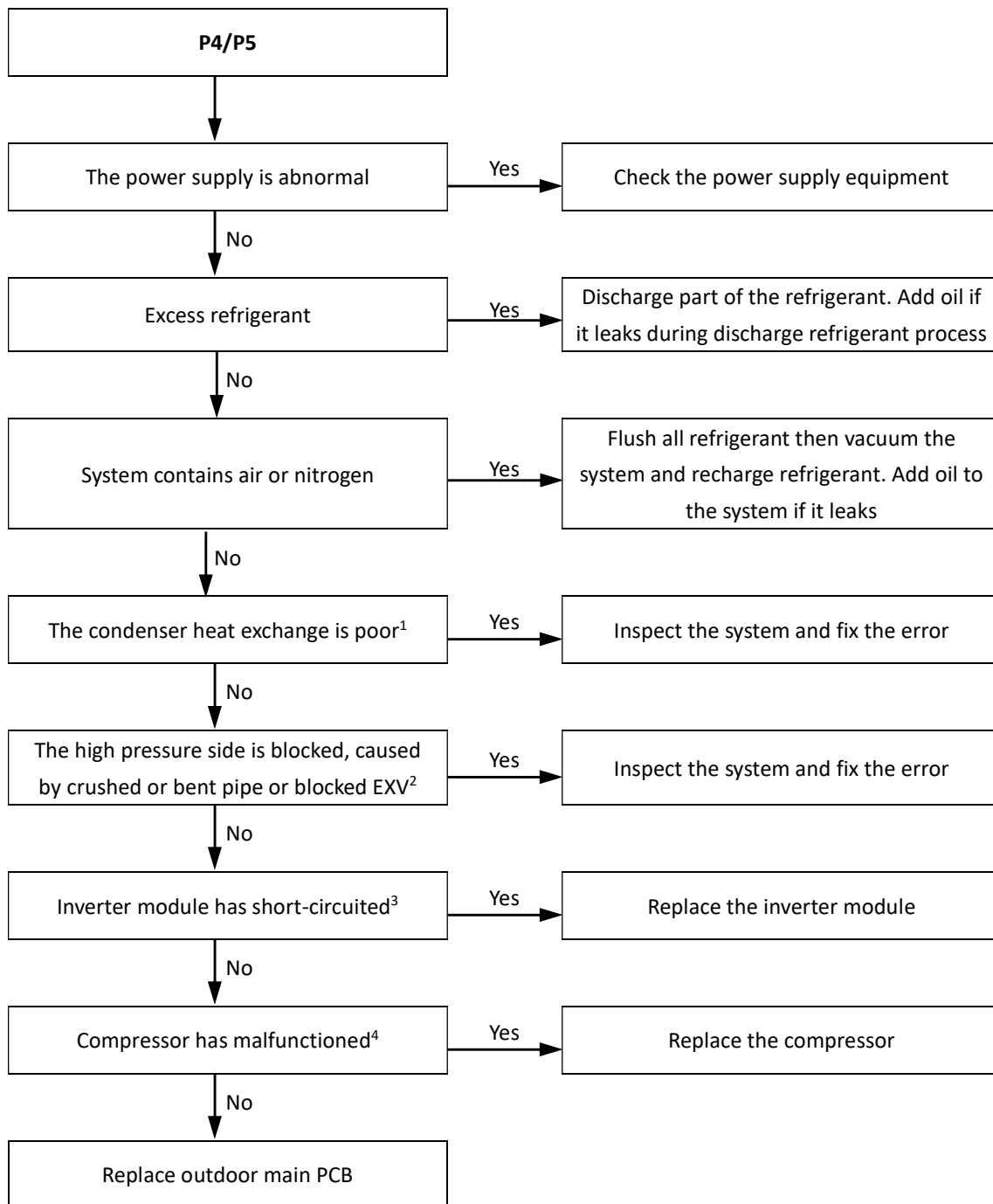

Notes:

1. In heating mode check water side heat exchanger, water piping, circulator pumps and water flow switch for dirt/blockages. In cooling mode check air side heat exchanger, fan(s) and air outlets for dirt/blockages.
2. High pressure side blockage causes discharge temperature to be higher than normal, discharge pressure to be higher than normal and suction pressure to be lower than normal.
3. Set a multi-meter to buzzer mode and test any two terminals of P N and U V W of the inverter module. If the buzzer sounds, the inverter module has short-circuited.
4. The normal resistances of the inverter compressor is 0.124Ω(at 20°C ambient temperature) among U V W and infinite between each of U V W and ground. If any of the resistances differ from these specifications, the compressor has malfunctioned.

5.13 P6 Troubleshooting (for SCV-900EB and SCV-1800EB)

5.13.1 Digital display output



5.13.2 Description

- Indicates inverter module failure
- When a P6 error occurs, a manual system restart is required before the system can resume operation. The cause of a P6 error should be addressed promptly in order to avoid system damage.
- All units stop running.
- Error code is displayed on the main PCB and user interface.

5.13.3 Possible causes

- Inverter module protection
- DC bus low or high voltage protection
- MCE error
- Zero speed protection
- Phase sequence error
- Excessive compressor frequency variation
- Actual compressor frequency differs from target frequency

5.13.4 Specific error codes for XP6 inverter module protection

If P6 error code is displayed, please spot check the specific error code through the wired controller.

Specific error code ¹	Content
xL0	Inverter module protection
xL1	DC bus low voltage protection
xL2	DC bus high voltage protection
xL4	MCE error
xL5	Zero speed protection
xL7	Phase sequence error
xL8	Compressor frequency variation greater than 15Hz within one second protection
xL9	Actual compressor frequency differs from target frequency by more than 15Hz protection

Notes:

1. 'x' is a placeholder for the compressor system (compressor and related electrical components), with 1 representing compressor system A and 2 representing compressor system B.

The specific error codes xL0, xL1, xL2 and xL4 can also be obtained from the inverter module LED indicators. If an inverter module error has occurred, LED2 is continuously on and LED1 flashes.

LED indicators LED1 and LED2 on inverter module

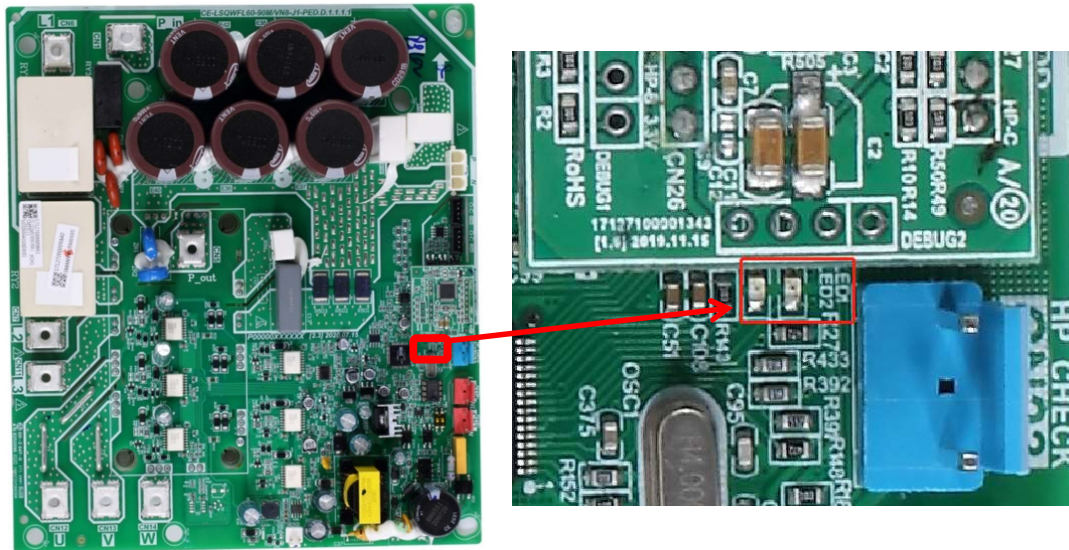

Errors indicated on LED1

LED1 flashing pattern	Corresponding error
Flashes 8 times and stops for 1 second, then repeats	xL0 - Inverter module protection
Flashes 9 times and stops for 1 second, then repeats	xL1 - DC bus low voltage protection
Flashes 10 times and stops for 1 second, then repeats	xL2 - DC bus high voltage protection
Flashes 12 times and stops for 1 second, then repeats	xL4 - MCE error

5.13.5 L0: Inverter module protection

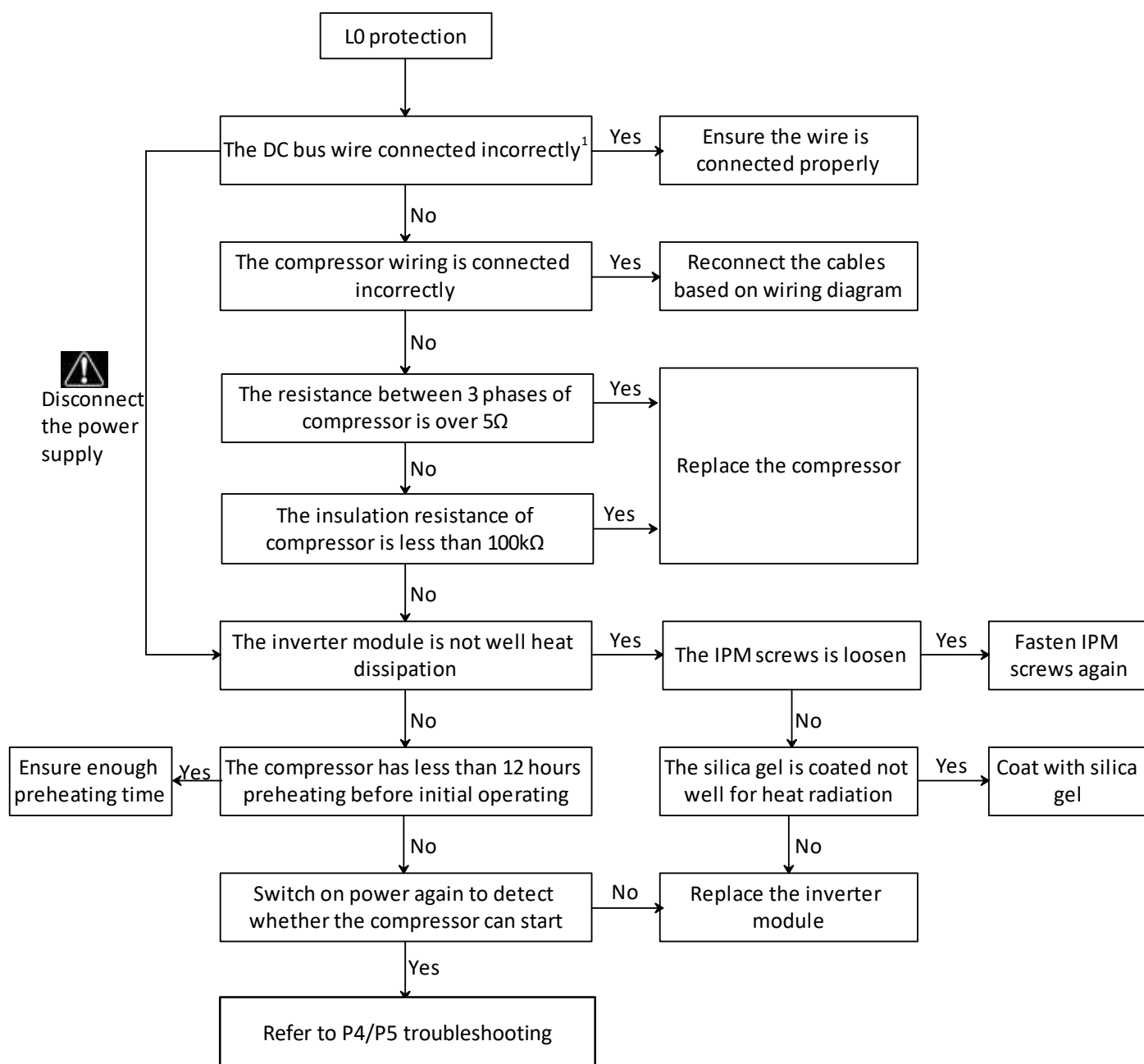

Note:

1. Make sure wire connection of CN38 port of compressor inverter module board is firm. Plug or pull out the wire under live working is not allowed.

- How to determine whether the compressor module is damaged?

IPM internal rectifier circuit

IPMM internal inverter circuit

- Three phase rectifier measure

Set the multimeter to diode position. After unit power off for 10min, put the black pin on CN5(P_OUT) and put the red pin on CN6(L1)、CN7(L2)、CN11(L3) respectively. If the voltage value is 0V, it means the three phase rectifier bridge reactor is damaged. Similarly, put the red pin on CN38 (N) and put the black pin on CN6 (L1), CN7 (L2) and CN11 (L3) respectively. If the voltage value is 0V, it means the three phase rectifier bridge reactor is damaged.

- Inverter circuit measure

Set the multimeter to diode position. After unit power off for 10min, put the black pin on CN1(P_in) and put the red pin on CN12(U)、CN13(V)、CN14(W) respectively. If the voltage value is 0V, it means the IGBT or freewheel diode is damaged. Similarly, put the red pin on CN38 (N) and put the black pin on CN12 (U), CN13 (V) and CN14 (W) respectively. If the voltage value is 0V, it means the IGBT or freewheel diode is damaged.

5.13.6 L1: Low-voltage protection

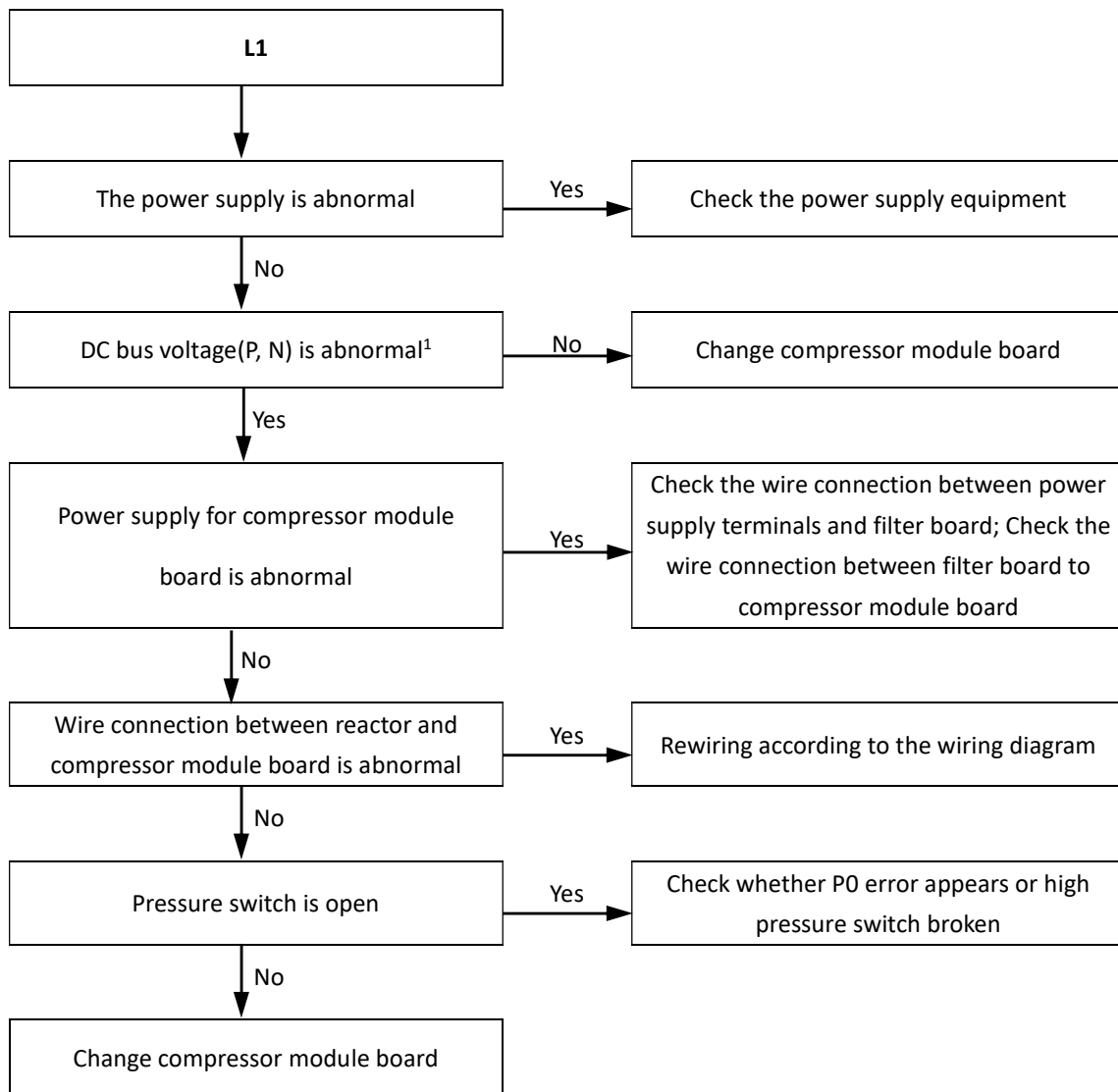

Note:

1. The normal DC voltage between terminals P and N of CN38 of compressor inverter module board should be 450-650V. When the voltage is lower than 350V.

5.13.7 L2: High-voltage protection

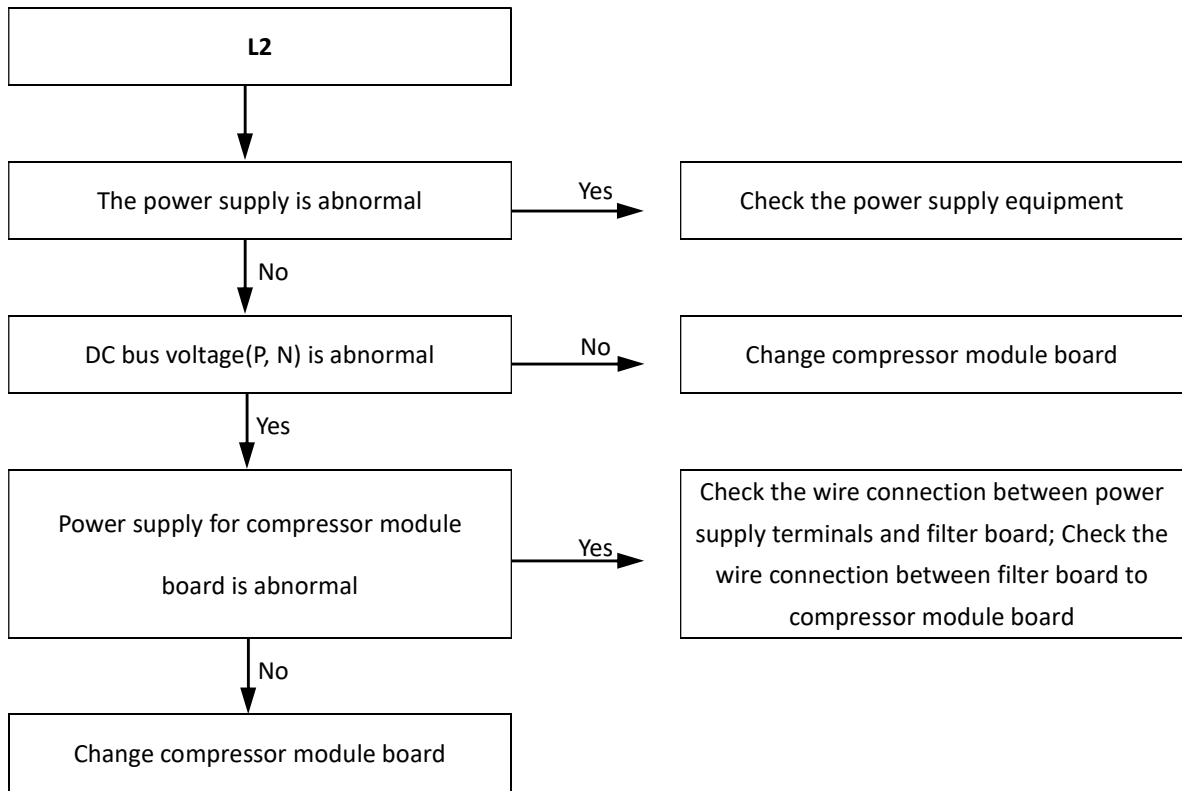

Note:

1. The normal DC voltage between terminals P and N on inverter module should be 450-650V. When the voltage is higher than 800V, L2 protection will be appeared.

5.13.8 L4: MCE error

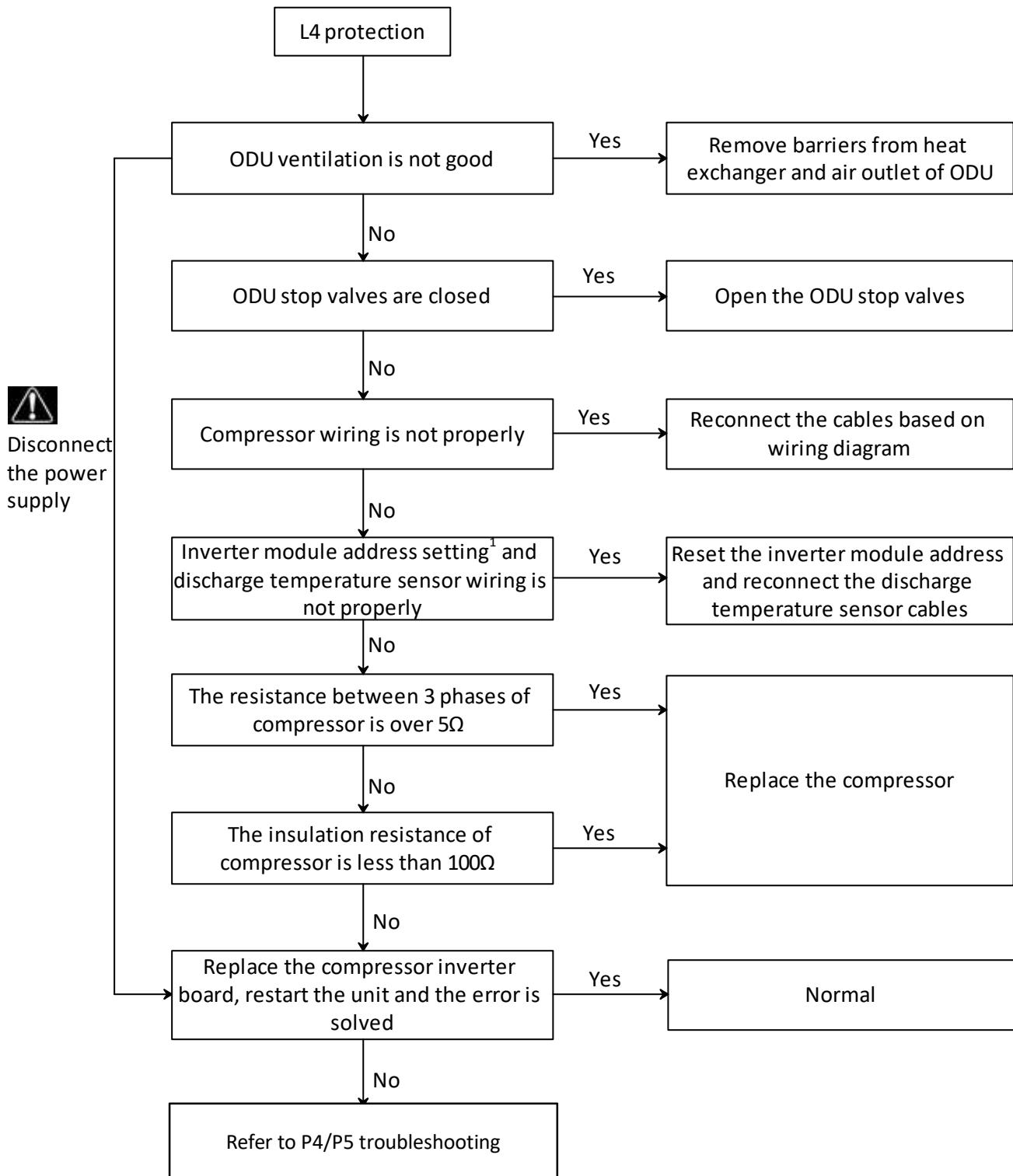

Notes:
 1. Compressor inverter module address is set through dial switch S7 on the inverter module. The compressor inverter module A/B location refers to the wiring diagram

Switch	Description	S7-1	S7-2
 S7	Compressor A inverter module address setting	OFF	OFF
	Compressor B inverter module address setting	OFF	ON

5.13.9 L7: Phase sequence error

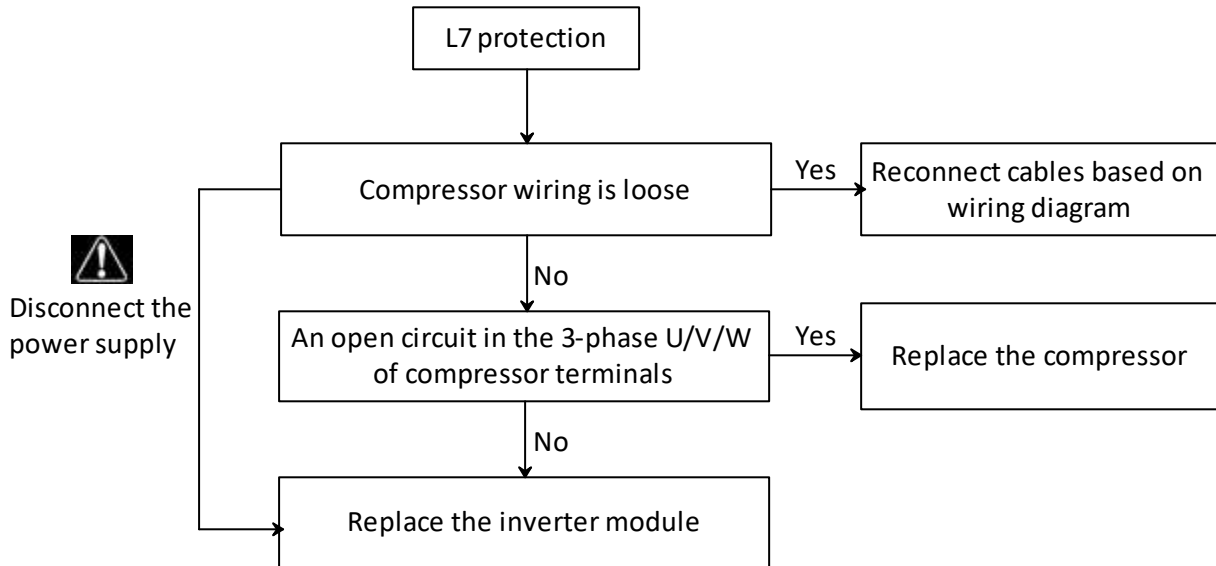

5.13.10 L8: Compressor frequency variation greater than 15Hz within one second protection

L9: Actual compressor frequency differs from target frequency by more than 15Hz protection

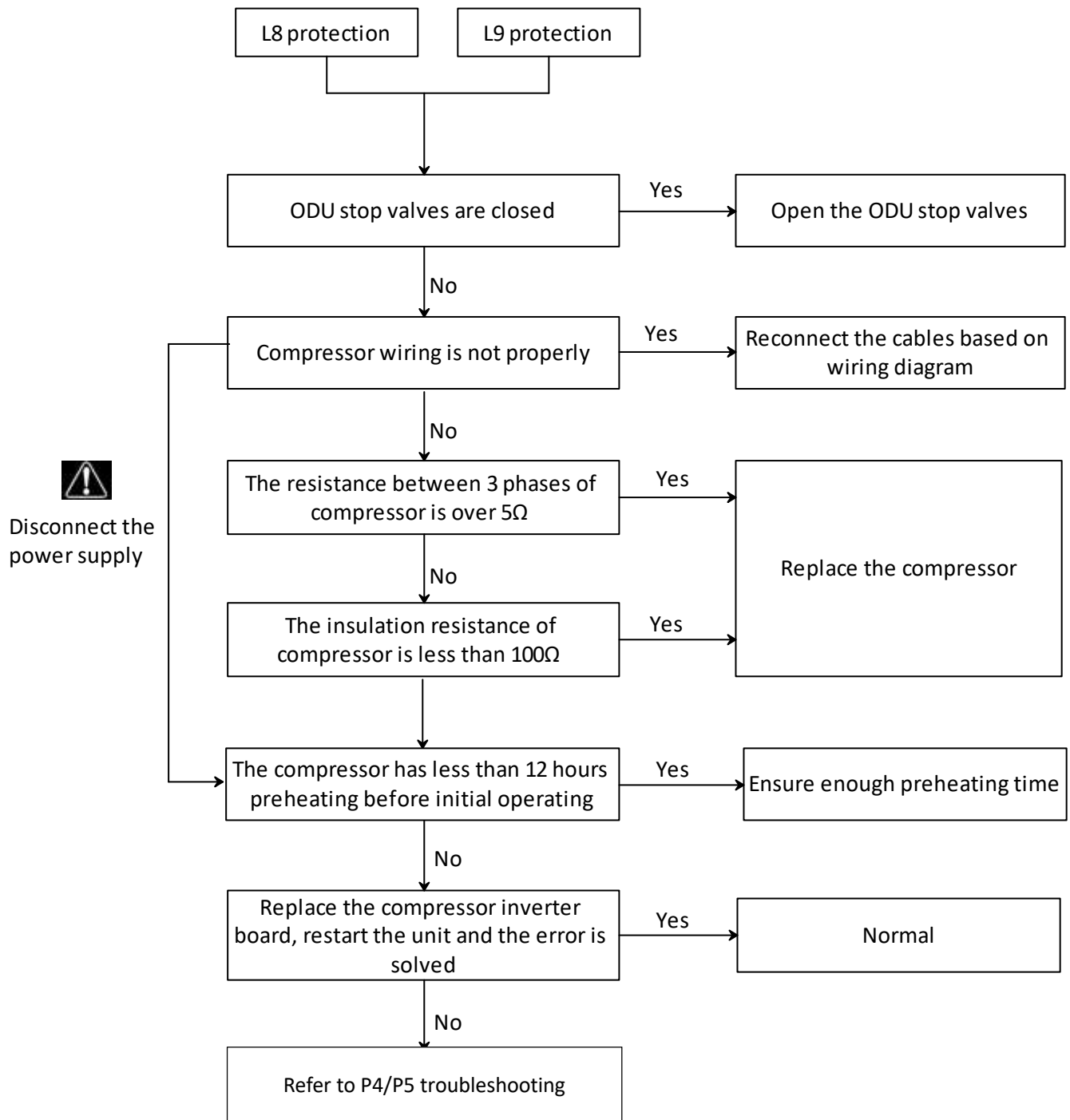

5.13.11 Compressor replacement procedure

Step 1: Remove faulty compressor and remove oil

- Remove the faulty compressor from the outdoor unit.
- Before removing the oil, shake the compressor so as to not allow impurities to remain settled at the bottom.
- Drain the oil out of the compressor and retain it for inspection. Normally the oil can be drained out from the compressor discharge pipe.



Step 2: Inspect oil from faulty compressor

- The oil should be clear and transparent. Slightly yellow oil is not an indication of any problems. However, if the oil is dark, black or contains impurities, the system has problems and the oil needs to be changed. Refer to Figure 4-4.20 for further details regarding inspecting compressor oil. (If the compressor oil has been spoiled, the compressor will not be being lubricated effectively. The scroll plate, crankshaft and bearings will wear. Abrasion will lead to a larger load and higher current. More electric energy will get dissipated as heat and the temperature of the motor will become increasingly high. Finally, compressor damage or burnout will result.)

Step 3: Check oil in other compressors in the system

- If the oil drained from the faulty compressor is clean, go to Step 6.
- If the oil drained from the faulty compressor is only lightly spoiled, go to Step 4.
- If the oil drained from the faulty compressor is heavily spoiled, check the oil in the other compressors in the system. Drain the oil from any compressors where the oil has been spoiled. Go to Step 4.

Step 4: Replace oil separator(s) and accumulator(s)

- If the oil from a compressor is spoiled (lightly or heavily), drain the oil from the oil separator and accumulator in that unit and then replace them.

Step 5: Check filters(s)

- If the oil from a compressor is spoiled (lightly or heavily), check the filter between the gas stop valve and the 4-way valve in that unit. If it is blocked, clean with nitrogen or replace.

Step 6: Replace the faulty compressor and re-fit the other compressors

- Replace the faulty compressor.
- If the oil had been spoiled and was drained from the non-faulty compressors in Step 3, use clean oil to clean them before re-fitting them into the units. To clean, add oil into the compressor through the discharge pipe using a funnel, shake the compressor, and then drain the oil. Repeat several times and then re-fit the compressors into the units. (The discharge pipe is connected to the oil pool of the compressor by the inner oil balance pipe.)

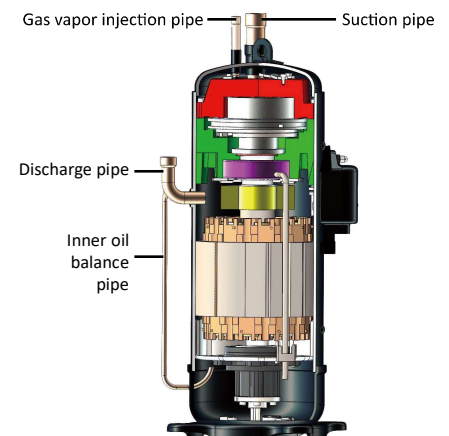

Step 7: Add compressor oil

- Please refer to the compressor specification for oil type. Different compressors require different types of oil. Using the wrong type of oil leads to various problems.
- The principle during changing compressor is to keep the system oil amount is the same as original state.

Step 8: Vacuum drying and refrigerant charging

- Once all the compressors and other components have been fully connected, vacuum dry the system and recharge refrigerant.

Inspecting compressor oil

This oil is black - it has been

This oil is a little yellow, but is clear and transparent and the condition is acceptable

This oil is still transparent but there are impurities which may clog the filter

Cloudy or gray oil indicates abnormal system

This oil contains particles of copper

Effects of spoiled compressor oil

Worn crankshaft

Filter blocked by impurities, which leads to abnormal compressor suction

Worn scroll plate

Worn scroll plate

Normal compressor bearings

Seriously worn and damaged bearings

5.14 dF Troubleshooting

5.14.1 Digital display output



5.14.2 Description

Normal defrost logic, resume after defrost, not fault.

5.15 P7 Troubleshooting

5.15.1 Digital display output



5.15.2 Description

For SCV-750EB and SCV-1400EB

- High temperature protection of air side heat exchanger tube temperature sensor “T3a / T3b” in cooling mode. When the tube temperature of air side heat exchanger is higher than 62°C, the system displays P7 protection and all units stop running. When the tube temperature of air side heat exchanger returns drops below 55°C, P7 is removed and normal operation resumes.
- All units stop running.
- Error code is displayed on main PCB and user interface.

For SCV-900EB and SCV-1800EB

- High temperature protection of air side heat exchanger refrigerant outlet temperature sensor or air side heat exchanger refrigerant total outlet temperature sensor in cooling mode. When the air side heat exchanger refrigerant outlet temperature is higher than 62°C, the system displays P7 protection and all units stop running. When the air side heat exchanger refrigerant outlet temperature returns drops below 55°C, P7 is removed and normal operation resumes.
- All units stop running.
- Error code is displayed on main PCB and user interface.

5.15.3 Possible causes

For SCV-750EB and SCV-1400EB

- Air side heat exchanger tube temperature sensor “T3a / T3b” not connected properly or has malfunctioned.
- Fan motor wiring connection is wrong.
- Poor condenser heat exchange.
- Fan motor damaged.
- Main PCB damaged.

For SCV-900EB and SCV-1800EB

- Air side heat exchanger refrigerant outlet temperature sensor or air side heat exchanger refrigerant total outlet temperature sensor not connected properly or has malfunctioned.
- Fan motor wiring connection is wrong.
- Poor condenser heat exchange.
- Fan motor damaged.
- Main PCB damaged.

5.15.4 Procedure

For SCV-750EB and SCV-1400EB

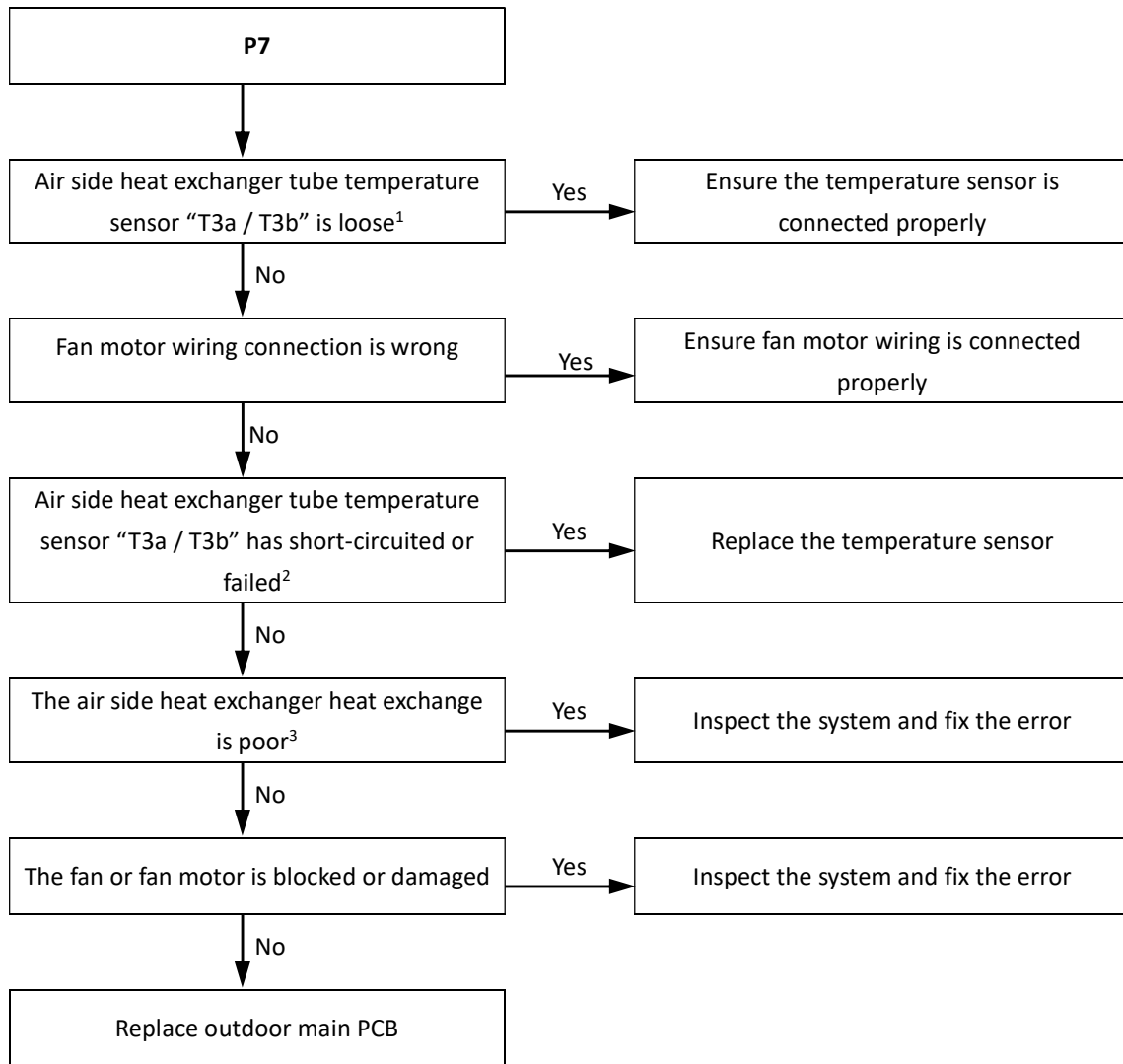

Notes:

1. Air side heat exchanger tube temperature sensor "T3a / T3b" connection port is CN37/CN16 on the main PCB (labeled 22,24 in Part 4, 2.2.1 Main PCB component)
2. Measure sensor resistance. If the resistance is too low, the sensor has short-circuited. If the resistance is not consistent with the sensor's resistance characteristics table, the sensor has failed. Refer to Part 4, 6.1 "Temperature Sensor Resistance Characteristics".
3. Check air side heat exchanger, fan(s) and air outlets for dirt/blockages.

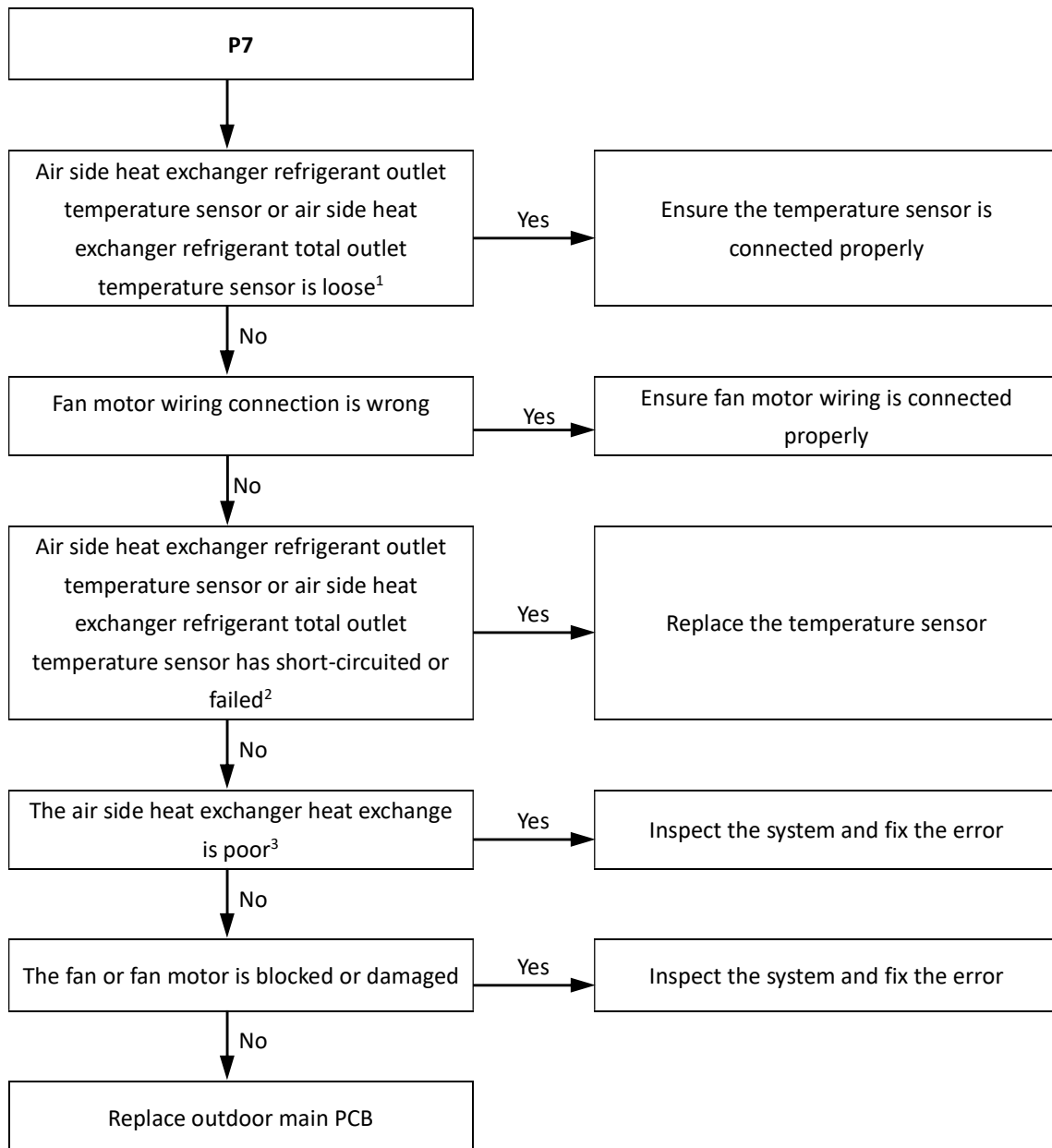

Notes:

4. Air side heat exchanger refrigerant outlet temperature sensor and air side heat exchanger refrigerant total outlet temperature sensor connection port is CN1 on the main PCB (labeled 29 in Part 4, 2.2.1 Main PCB component)
5. Measure sensor resistance. If the resistance is too low, the sensor has short-circuited. If the resistance is not consistent with the sensor's resistance characteristics table, the sensor has failed. Refer to Part 4, 6.1 "Temperature Sensor Resistance Characteristics".
6. Check air side heat exchanger, fan(s) and air outlets for dirt/blockages.

5.16 P9 Troubleshooting

5.16.1 Digital display output



5.16.2 Description

- Water inlet and outlet temperature difference protection
- All units stop running.
- Error code is displayed on main PCB and user interface.

5.16.3 Possible causes

- Temperature sensor not connected properly or has malfunctioned.
- Water piping contains air.
- Insufficient water flow.
- Main PCB damaged.

5.16.4 Procedure

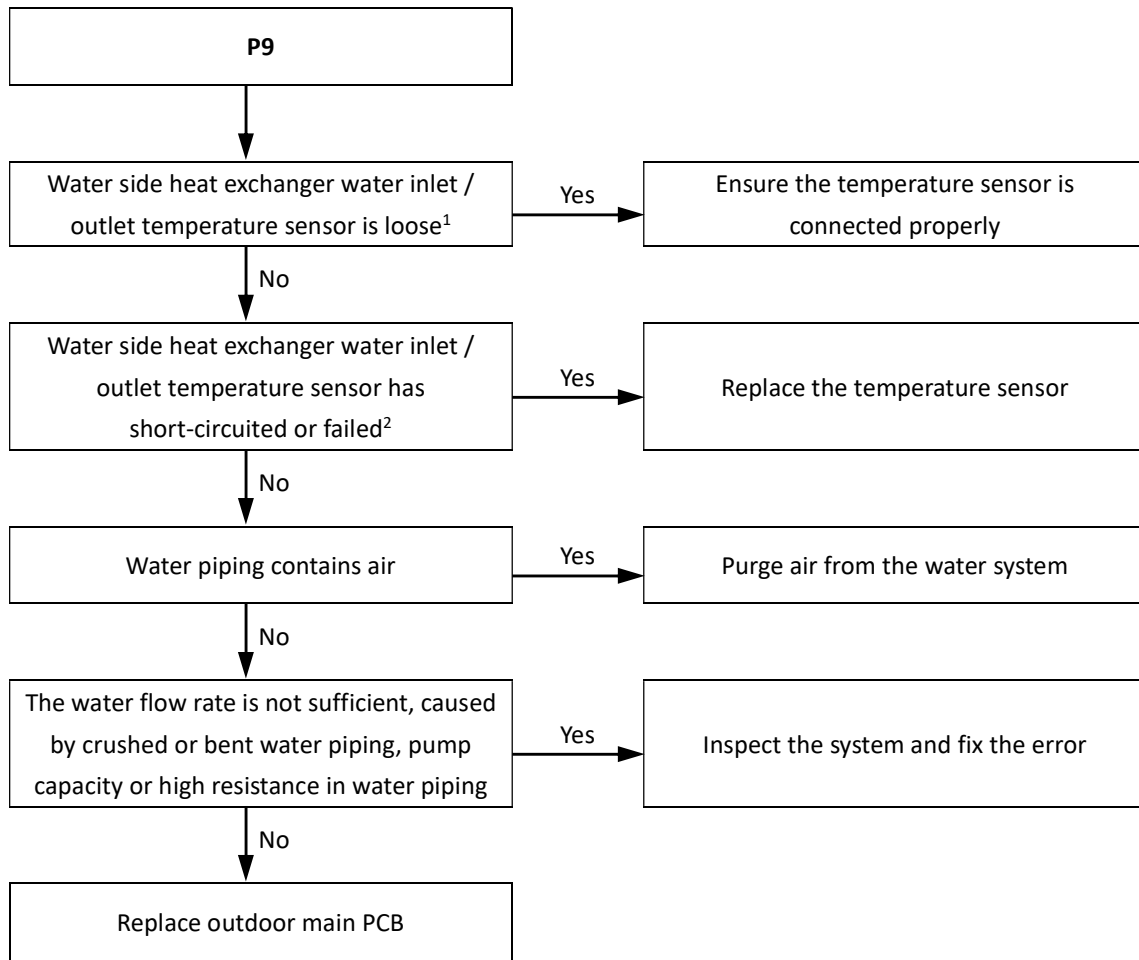

Notes:

1. For SCV-900EB and SCV-1800EB, water side heat exchanger water inlet temperature sensor and water side heat exchanger water outlet temperature sensor connections are port CN4 on the main PCB (labeled 29 in Part 4, 2.2.1 Main PCB component). For SCV-900EB and SCV-1800EB, water side heat exchanger water inlet temperature sensor and water side heat exchanger water outlet temperature sensor connections are port CN31 on the main PCB (labeled 31 in Part 4, 2.2.1 Main PCB component);
2. Measure sensor resistance. If the resistance is too low, the sensor has short-circuited. If the resistance is not consistent with the sensor's resistance characteristics table, the sensor has failed. Refer to Part 4, 6.1 "Temperature Sensor Resistance Characteristics".

5.17 Pb Troubleshooting

5.17.1 Digital display output



5.17.2 Description

- Water side heat exchanger anti-freeze protection.
- All units stop running.
- Error code is displayed on main PCB and ANTI.FREEZE icon is displayed on user interface.

5.17.3 Possible causes

- Normal system protection.
- Temperature sensor not connected properly or has malfunctioned.
- For SCV-750EB and SCV-1400EB, main PCB or slave PCB damaged;
For SCV-900EB and SCV-1800EB, main PCB damaged.

5.17.4 Procedure

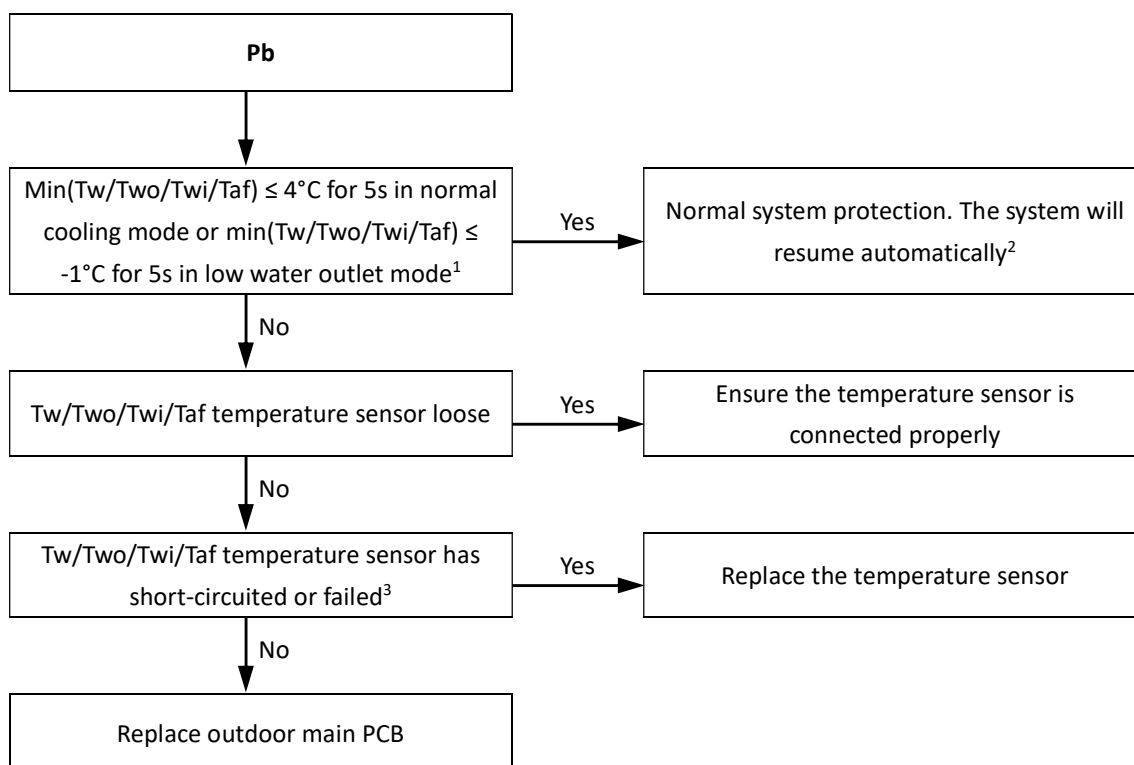

Notes:

1. For SCV-750EB and SCV-1400EB, combined Water side heat exchanger water outlet temperature sensor(Two), water side heat exchanger water inlet temperature sensor (Twi) and water side heat exchanger anti-freezing temperature sensor(Taf2) connections are ports CN4 and CN45 on the main PCB(labeled 29,21 in Part 4, 2.2.1 Main PCB component).Water outlet temperature sensor (Tw) connections is ports CN101 on the slave PCB (labeled 14 in Part 4, 2.7 Slave PCB component).
2. For SCV-900EB and SCV-1800EB, combined water outlet temperature sensor (Tw), Water side heat exchanger water outlet temperature sensor(Two), water side heat exchanger water inlet temperature sensor (Twi) and water side heat exchanger anti-freezing temperature sensor(Taf, include Taf1 and Taf2) connections are ports CN31 and CN69 on the main PCB (labeled 31,32 in Part 4, 2.2.1 Main PCB component).
3. Refer to Part 3, 6.7 "Water Side Heat Exchanger Anti-freeze Protection Control".
4. Measure sensor resistance. If the resistance is too low, the sensor has short-circuited. If the resistance is not consistent with the sensor's resistance characteristics table, the sensor has failed. Refer to Part 4, 6.1 "Temperature Sensor Resistance Characteristics".

5.18 PC Troubleshooting

5.18.1 Digital display output



5.18.2 Description

- Water side heat exchanger low pressure protection.
- All units stop running.
- Error code is displayed on main PCB and user interface.

5.18.3 Possible causes

- Low pressure switch not connected properly or has malfunctioned.
- Insufficient refrigerant.
- Low pressure side blockage.
- Poor evaporator heat exchange in heating mode.
- Insufficient water flow in cooling mode.
- Main PCB damaged.

5.18.4 Procedure

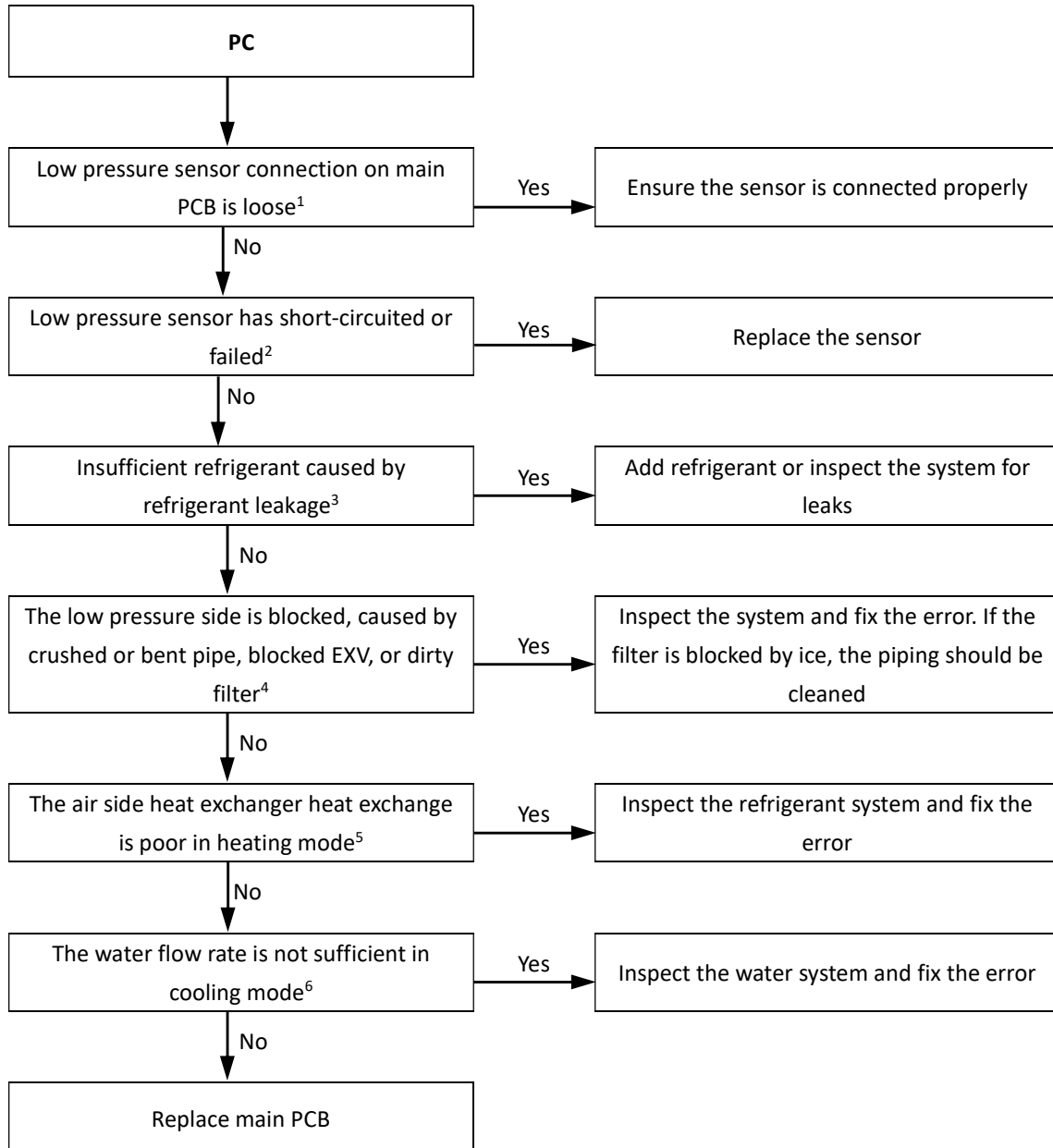

Notes:

1. For SCV-750EB and SCV-1400EB, low pressure sensor connection is port CN42 on the main PCB (labeled 27 in Part 4, 2.2.1 Main PCB component). For SCV-900EB and SCV-1800EB, low pressure sensor connection is port CN16 on the main PCB (labeled 30 in Part 4, 2.2.1 Main PCB component);
2. Measure the resistance among the three terminals of the pressure sensor. If the resistance is of the order of mega Ohms or infinite, the pressure sensor has failed;
3. To check for insufficient refrigerant: An insufficiency of refrigerant causes compressor discharge temperature to be higher than normal, discharge and suction pressures to be lower than normal and compressor current to be lower than normal, and may cause frosting to occur on the suction pipe. These issues disappear once sufficient refrigerant has been charged into the system;
4. A low pressure side blockage causes compressor discharge temperature to be higher than normal, suction pressure to be lower than normal and compressor current to be lower than normal, and may cause frosting to occur on the suction pipe. For normal system parameters;
5. Check air side heat exchanger, fan(s) and air outlets for dirt/blockages;
6. Check water side heat exchanger, water piping, circulator pumps and water flow switch for dirt/blockages.

5.19 PH Troubleshooting

5.19.1 Digital display output



5.19.2 Description

- Ambient temperature too high protection in heating mode.
- All units stop running.
- Error code is displayed on main PCB and user interface.

5.19.3 Possible causes

- Temperature sensor not connected properly or has malfunctioned.
- Actual ambient temperature is higher than 43°C.
- Main PCB damaged.

5.19.4 Procedure

For SCV-750EB and SCV-1400EB

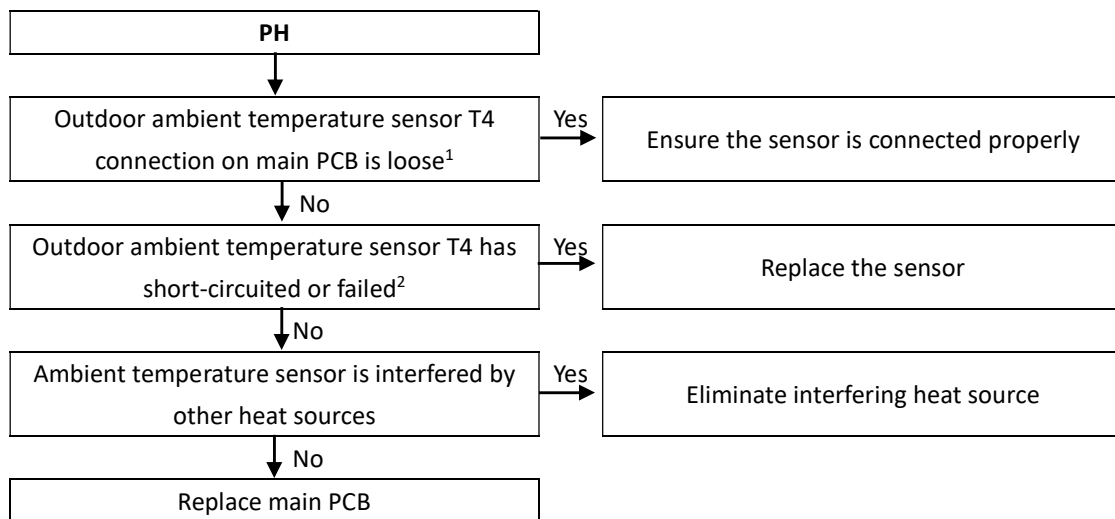

Notes:

1. T4 temperature sensor connection is port CN30 on the main PCB (labeled 23 in Part 4, 2.2.1 Main PCB component).
2. Measure sensor resistance. If the resistance is too low, the sensor has short-circuited. If the resistance is not consistent with the sensor's resistance characteristics table, the sensor has failed. Refer to Table 5-5.1 in Part 5, 5.1 "Temperature Sensor Resistance Characteristics".

For SCV-900EB and SCV-1800EB

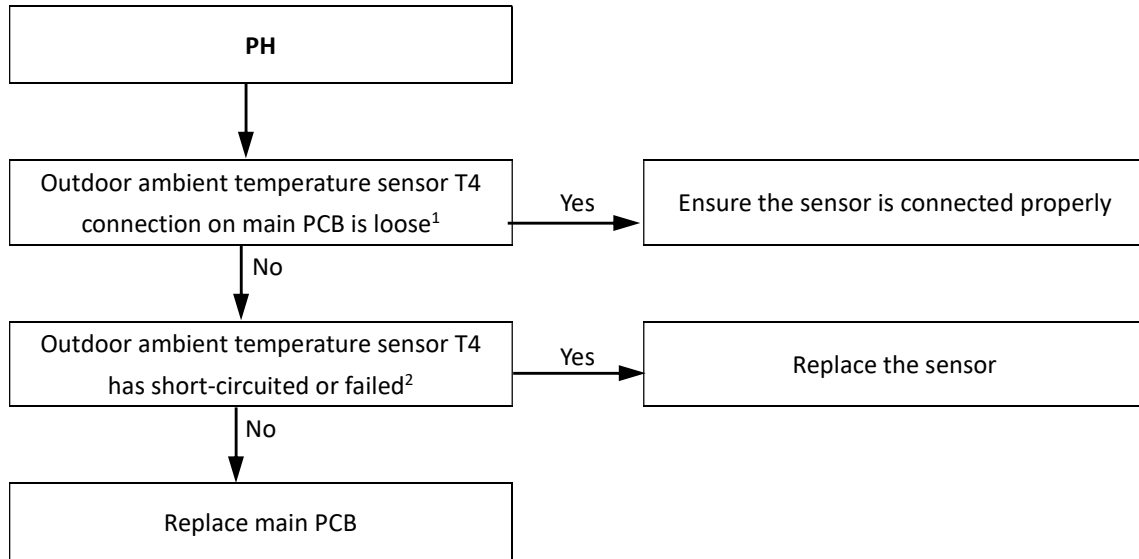

Notes:

3. T4 temperature sensor connection is port CN1 on the main PCB (labeled 29 in Part 4, 2.2.1 Main PCB component).
4. Measure sensor resistance. If the resistance is too low, the sensor has short-circuited. If the resistance is not consistent with the sensor's resistance characteristics table, the sensor has failed. Refer to Table 5-5.1 in Part 5, 5.1 "Temperature Sensor Resistance Characteristics".

5.20 PE Troubleshooting

5.20.1 Digital display output



5.20.2 Description

- Water side heat exchanger low temperature antifreeze protection.
- All units stop running.
- Error code is displayed on main PCB and user interface.

5.20.3 Possible causes

- Temperature sensor not connected properly or has malfunctioned.
- Insufficient refrigerant.
- Low pressure side blockage.
- Poor evaporator heat exchange in heating mode.
- Insufficient water flow in cooling mode.
- Main PCB damaged.

5.20.4 Procedure

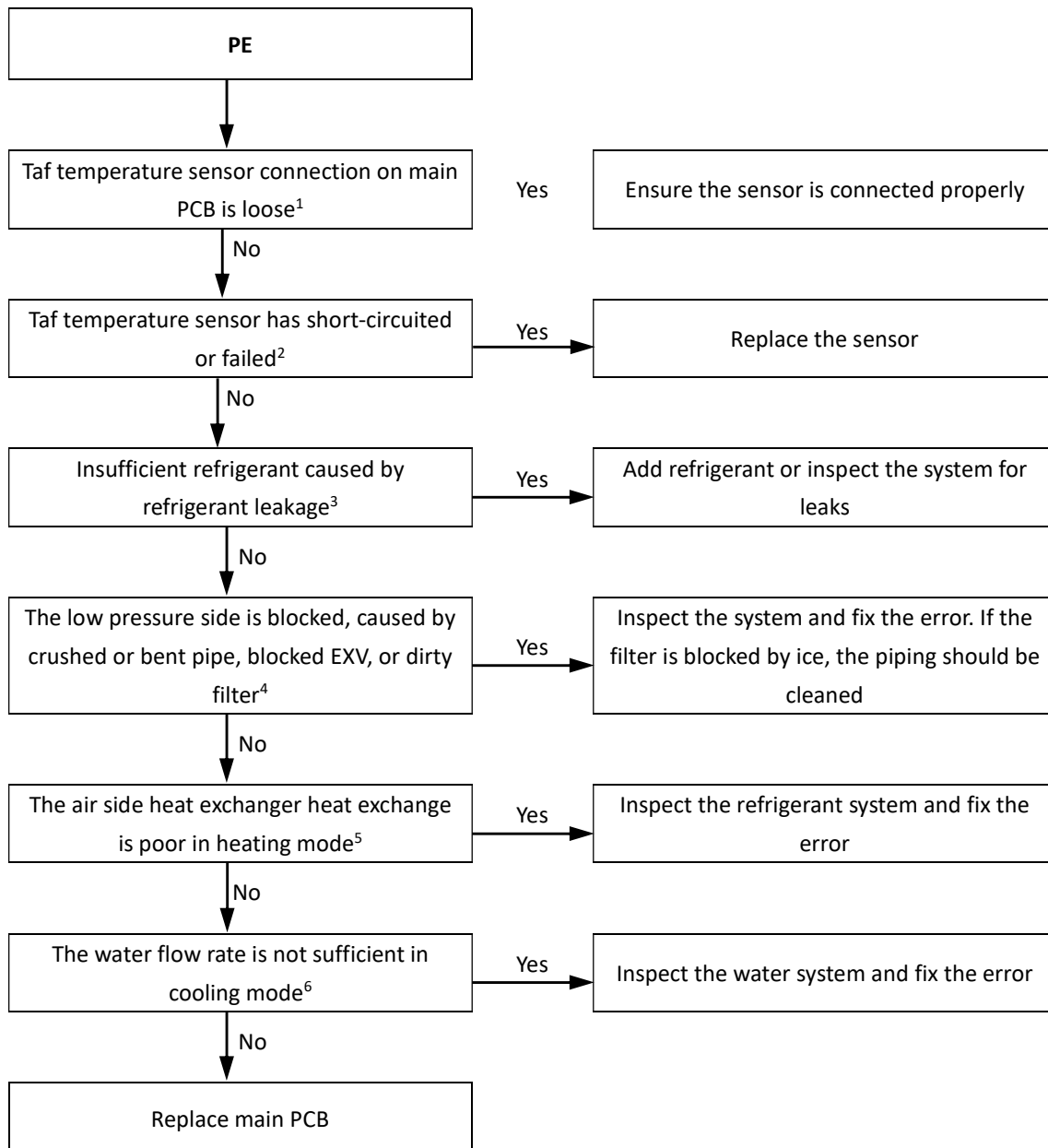

Notes:

1. For SCV-750EB and SCV-1400EB, Water side heat exchanger anti-freezing temperature sensor (Taf2) connection are ports CN45 on the main PCB (labeled 21 in Part 4, 2.2.1 Main PCB component). For SCV-900EB and SCV-1800EB, Water side heat exchanger anti-freezing temperature sensor (Taf, include Taf1 and Taf2) connection are ports CN31 and CN69 on the main PCB (labeled 31,32 in Part 4, 2.2.1 Main PCB component);
2. Measure sensor resistance. If the resistance is too low, the sensor has short-circuited. If the resistance is not consistent with the sensor's resistance characteristics table, the sensor has failed. Refer to Part 4, 6.1 "Temperature Sensor Resistance Characteristics";
3. To check for insufficient refrigerant: an insufficiency of refrigerant causes compressor discharge temperature to be higher than normal, discharge and suction pressures to be lower than normal and compressor current to be lower than normal, and may cause frosting to occur on the suction pipe. These issues disappear once sufficient refrigerant has been charged into the system;
4. A low pressure side blockage causes compressor discharge temperature to be higher than normal, suction pressure to be lower than normal and compressor current to be lower than normal, and may cause frosting to occur on the suction pipe. For normal system parameters;
5. Check air side heat exchanger, fan(s) and air outlets for dirt/blockages;
6. Check water side heat exchanger, water piping, circulator pumps and water flow switch for dirt/blockages.

5.21 PL/C7 Troubleshooting

5.21.1 Digital display output



5.21.2 Description

- PL indicates inverter module temperature protection. When the main inverter module temperature rises above 100°C, the system displays PL protection and all the units stop running. When the inverter module temperature drops below 70°C, the compressor enters re-start control
- When a PL error occurs 3 times in 100 minutes, C7 will display, a manual system restart is required before the system can resume operation.
- Error code is displayed on the main PCB and user interface.

5.21.3 Possible causes

- Blocked, dirty or loose heat sink.
- Temperature sensor not connected properly or has malfunctioned.
- Fan motor wiring connection is wrong.
- Main PCB damaged.

5.21.4 Procedure

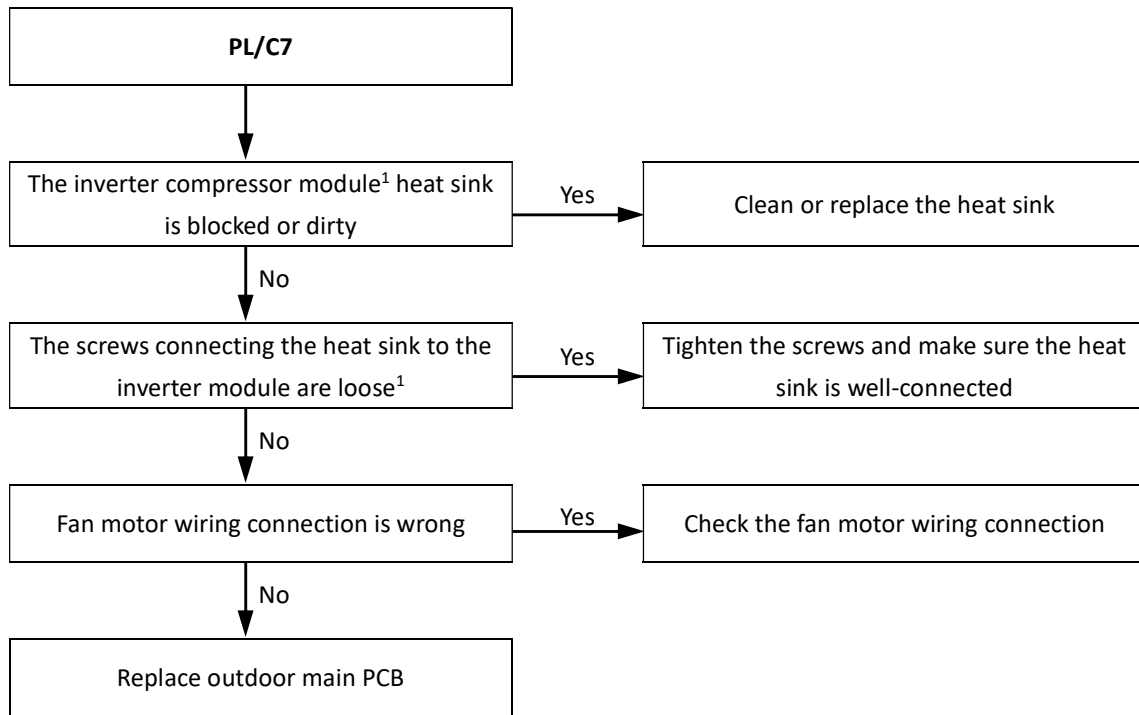

Notes:

1. Refer to Part 4, 1 "Electric Control Box Layout".

5.22 PU/FF Troubleshooting

5.22.1 Digital display output

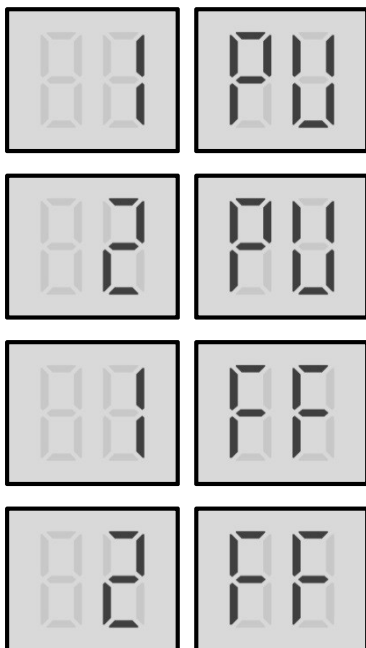

5.22.2 Description

- 1PU/FF indicates fan A module protection.
- 2PU/FF indicates fan B module protection.
- FF indicates PU protection has displayed 10 times. When a FF occurred, a manual system restart is required before the system can resume operation.
- All units stop running.
- Error code is only displayed on the main PCB and user interface.

5.22.3 Possible causes

- Switch SW1 incorrectly set.
- Power or communication wires not connected properly.
- Fan motor blocked or has failed.
- Power supply abnormal.
- AC filter board damaged.
- Fan module damaged.
- Inverter module PCB damaged.

5.22.4 Procedure

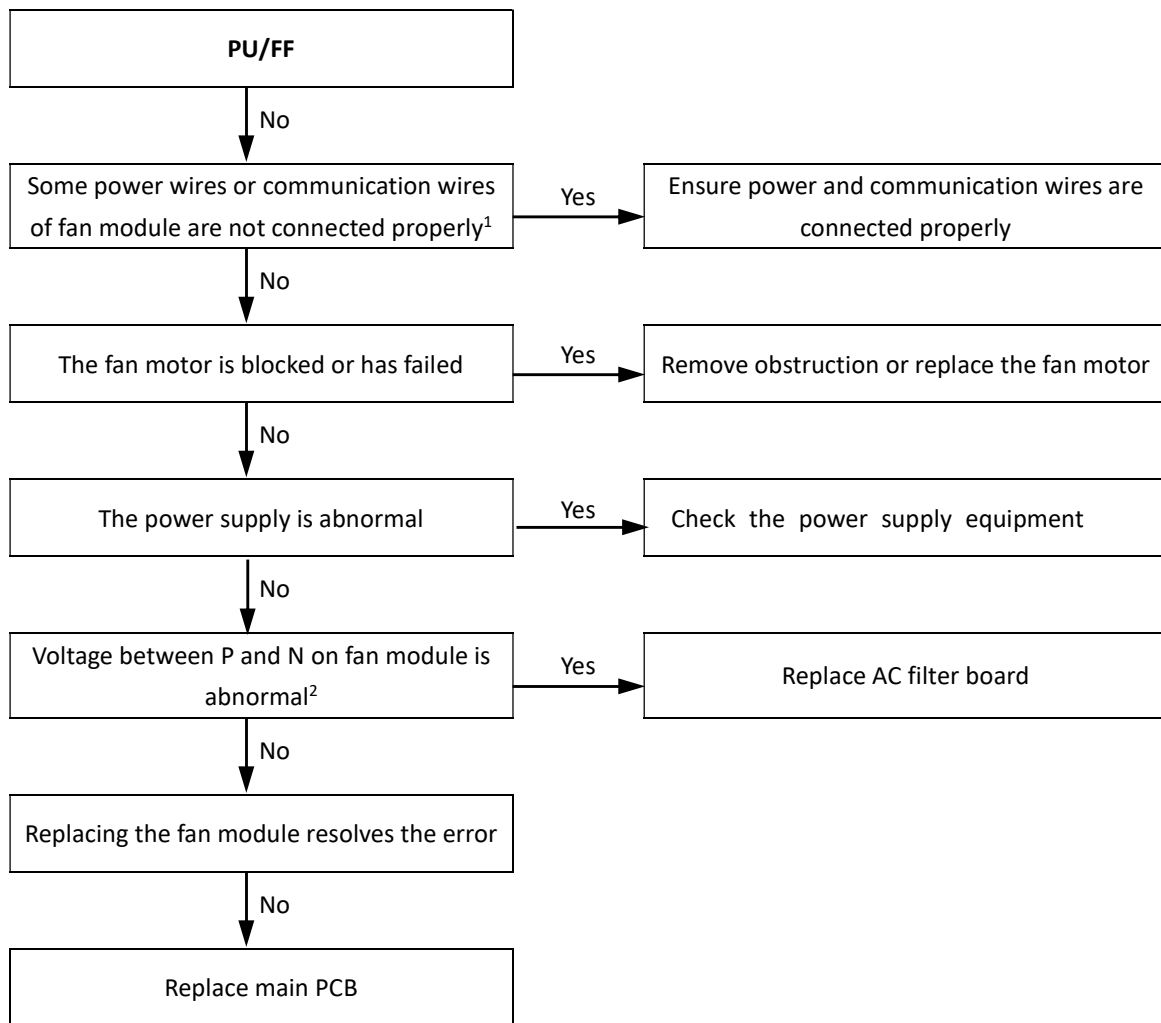

Notes:

1. Refer to Part 4, 3 "Wiring diagram" and PCB components to make sure wire connection is firm.
2. The normal voltage between P and N on the fan module is 650V DC. Refer to Part 4, 1 "Outdoor Unit Electric Control Box Layout" and to Part 4, 2.4 "Fan module board".

5.23 F0 Troubleshooting

5.23.1 Digital display output

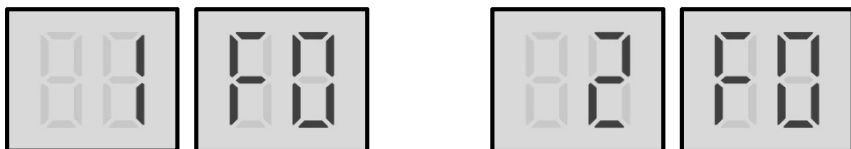

5.23.2 Description

- 1F0 indicates a communication error between the main control chip and the compressor A inverter driver chip.
- 2F0 indicates a communication error between the main control chip and the compressor B inverter driver chip.
- All units stop running.
- Error code is only displayed on the unit with the error.

5.23.3 Trigger / recover condition

- Trigger condition: Main control chip and inverter driver chip cannot communication for 2 minutes.
- Recover condition: Communication go back to normal.
- Reset method: Resume automatically.

5.23.4 Possible causes

- Incorrect compressor inverter module address setting.
- Loosened communication wiring from the main PCB to the inverter module.
- Bridge rectifier damaged.
- Main PCB damaged.
- Compressor inverter module damaged.

5.23.5 Procedure,

For SCV-750EB and SCV-1400EB

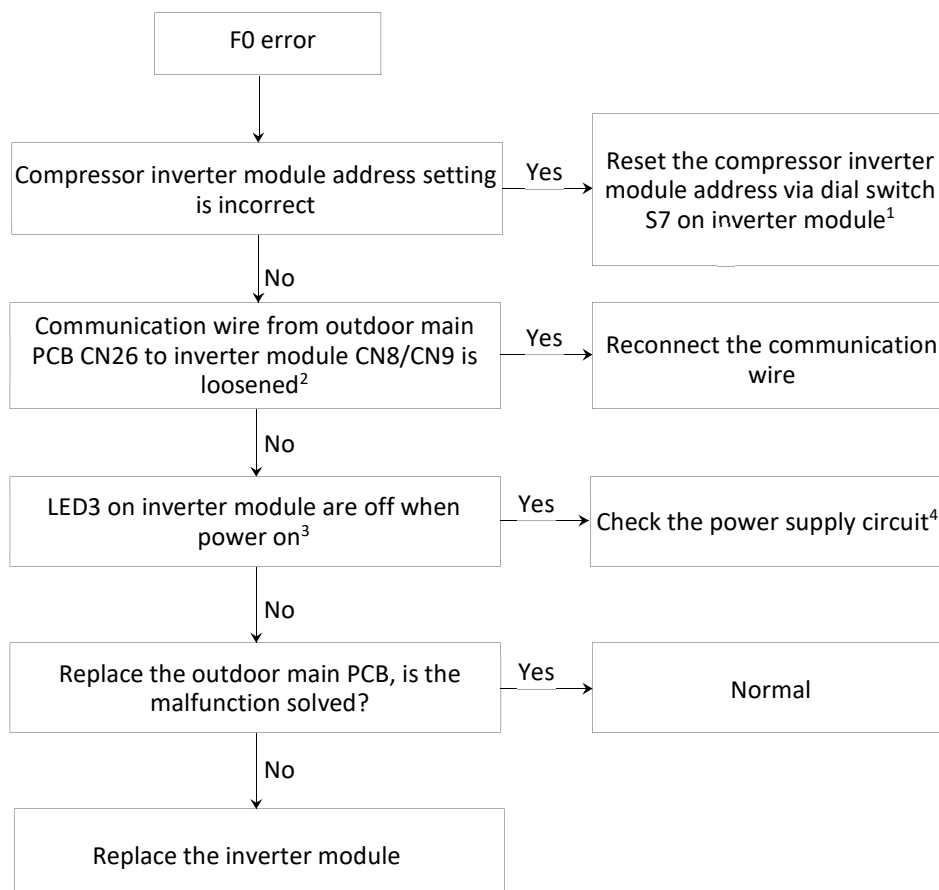

Notes:

- Compressor inverter module address is set through dial switch S7 on the inverter module. The compressor inverter module A/B location refers to the wiring diagram.

Switch	Description	S7-1	S7-2
<p>S7</p> 	Compressor A inverter module address setting	OFF	OFF
	Compressor B inverter module address setting	OFF	ON

- Communication wire from outdoor main PCB CN26 to inverter module CN8/CN9.

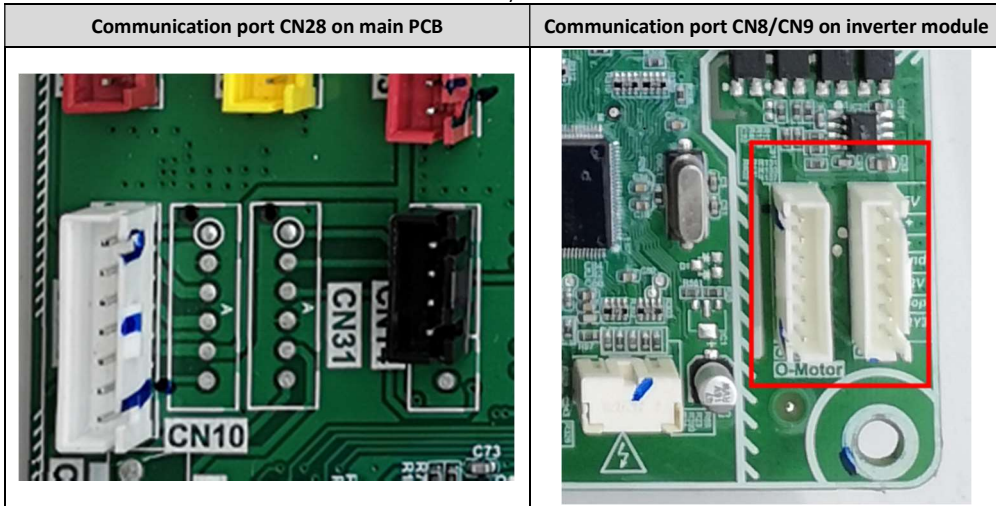

- LED3 on inverter module

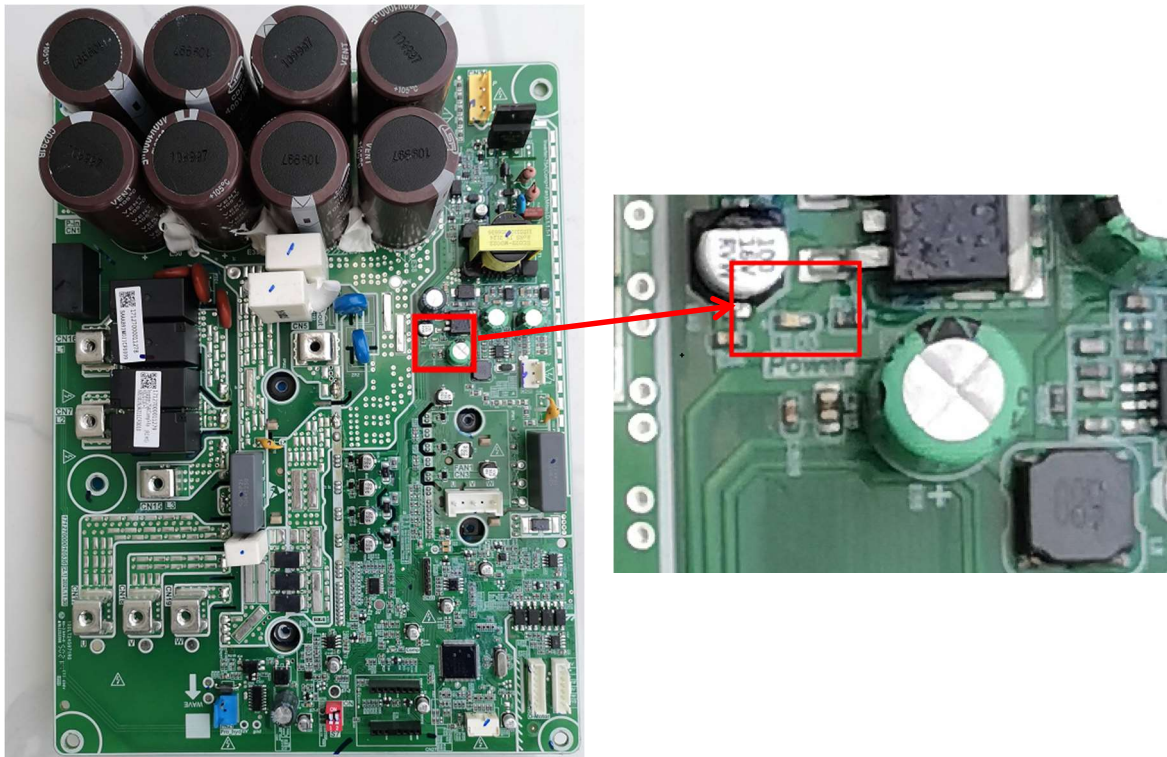

- Check the wired connection between CN5/CN6/CN7 of filter board and CN6/CN7/CN15 of compressor module board, the normal voltage should be 380-415VAC.

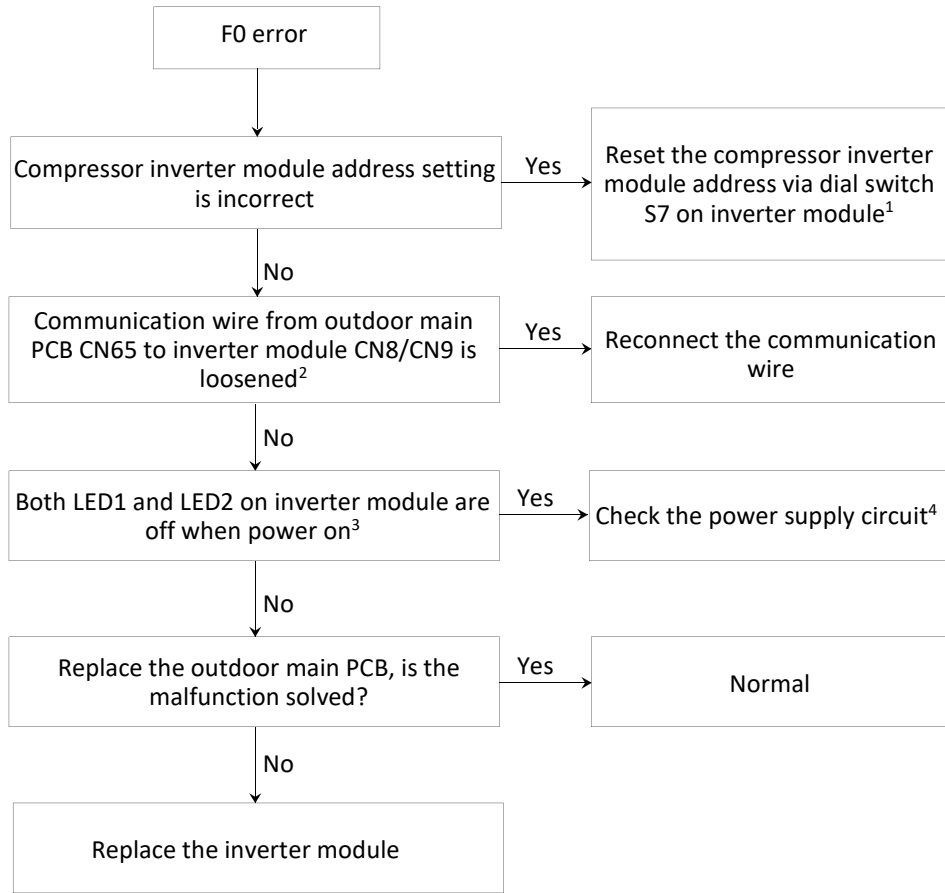

Notes:

1. Compressor inverter module address is set through dial switch S7 on the inverter module. The compressor inverter module A/B location refers to the wiring diagram.

Switch	Description	S7-1	S7-2
	Compressor A inverter module address setting	OFF	OFF
	Compressor B inverter module address setting	OFF	ON

2. Communication wire from outdoor main PCB CN65 to inverter module CN8/CN9.

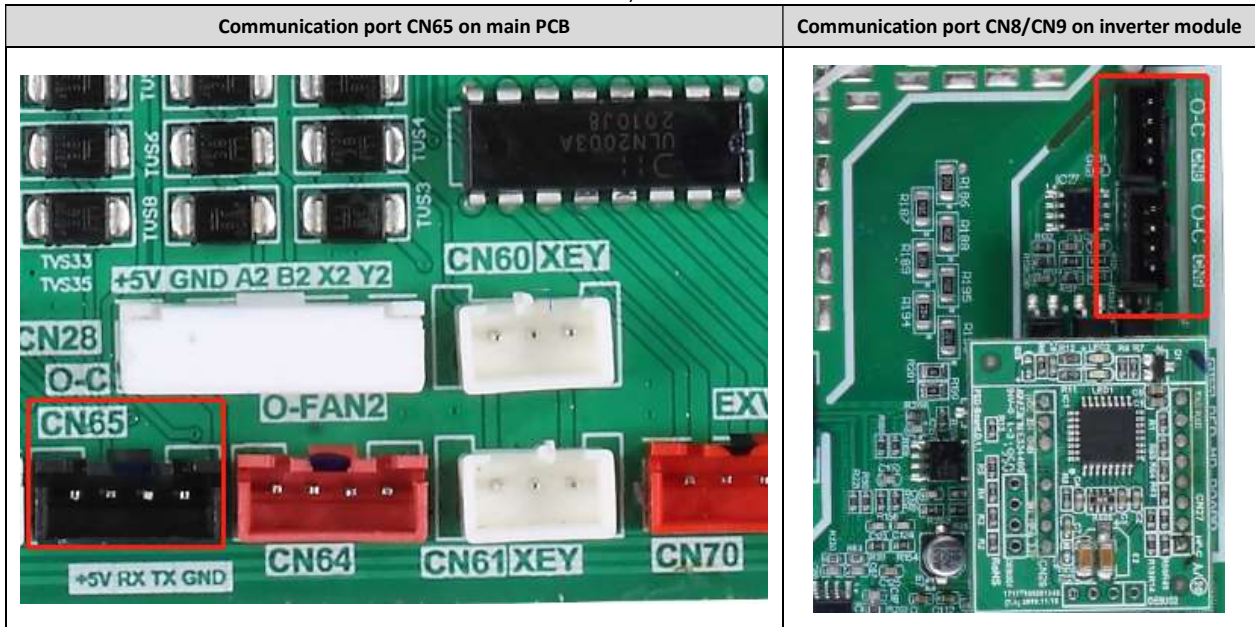

3. ED1/2 on inverter module

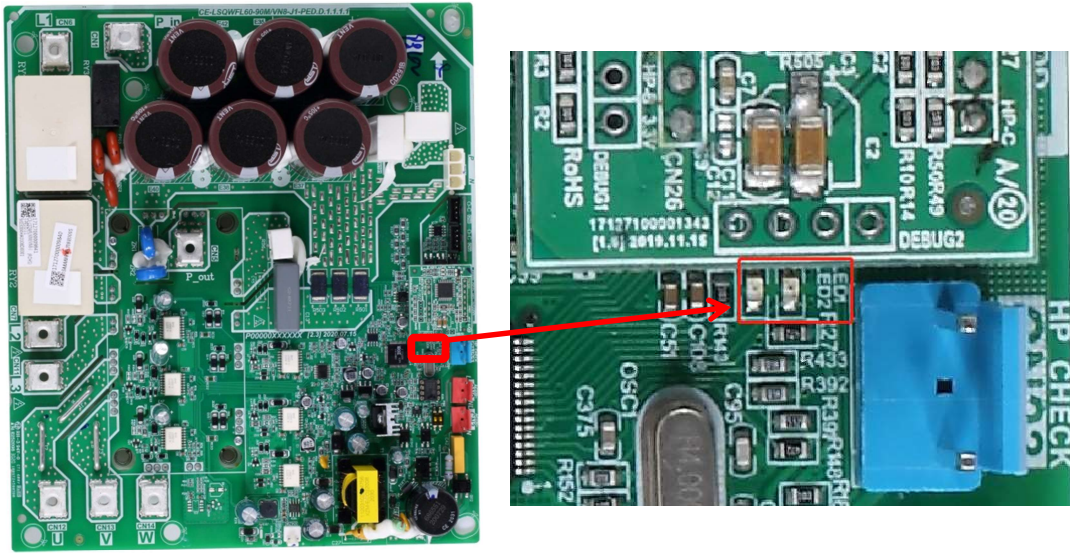

4. Check the wired connection between CN36 of filter board and CN2/CN3 of compressor module board, the normal voltage should be 230AC.
Check the wired connection between CN30 of filter board and CN58 of main control board, the normal voltage should be DC12V.

5.24 H5 Troubleshooting

5.24.1 Digital display output



5.24.2 Description

- Abnormal power supply voltage.
- All units stop running.
- Error code is only displayed on main PCB and user interface.

5.24.3 Possible causes

- Outdoor unit power supply voltage at or above 265V or drops below 170V or a phase is missing.
- Loosened wiring within electric control box.
- High voltage circuit error.
- Main PCB damaged.

5.24.4 Procedure

For SCV-750EB and SCV-1400EB

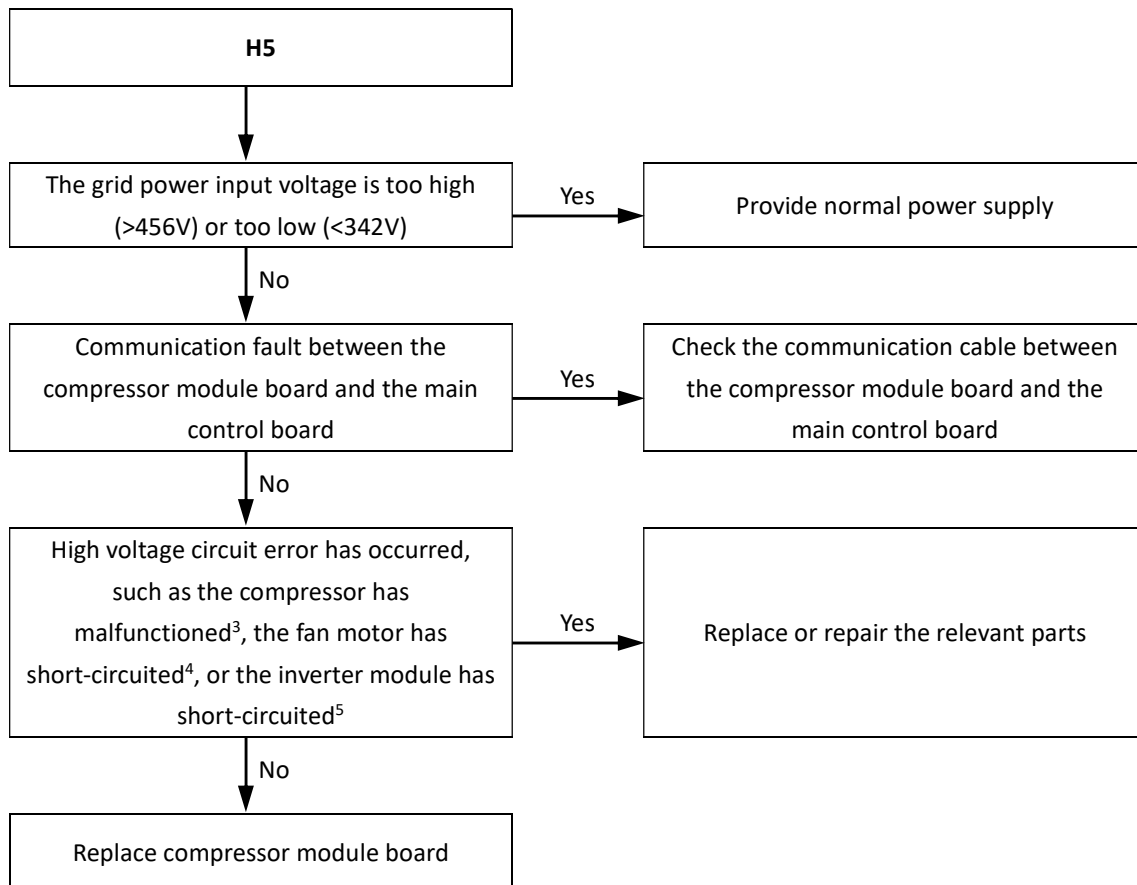

Notes:

1. The detected voltage is detected by the compressor module board and sent to the main control board, and the main control board judges according to the voltage value sent by the compressor module board (report a fault if it is >456V or <342V).
2. Refer to Part 4, 3 "Wiring diagram" and PCB components to make sure wire connection is firm.
3. The normal resistances of the inverter compressor is 0.124Ω (at 20°C ambient temperature) among U V W and infinite between each of U V W and ground. If any of the resistances differ from these specifications, the compressor has malfunctioned.
4. The normal resistances of the fan motor coil among U V W are less than 15Ω. If a measured resistance is 0Ω, the fan motor has short-circuited.
5. Set a multi-meter to buzzer mode and test any two terminals of P N and U V W of the inverter module. If the buzzer sounds, the inverter module has short-circuited. Refer to Part 4, 1 "Outdoor Unit Electric Control Box Layout".

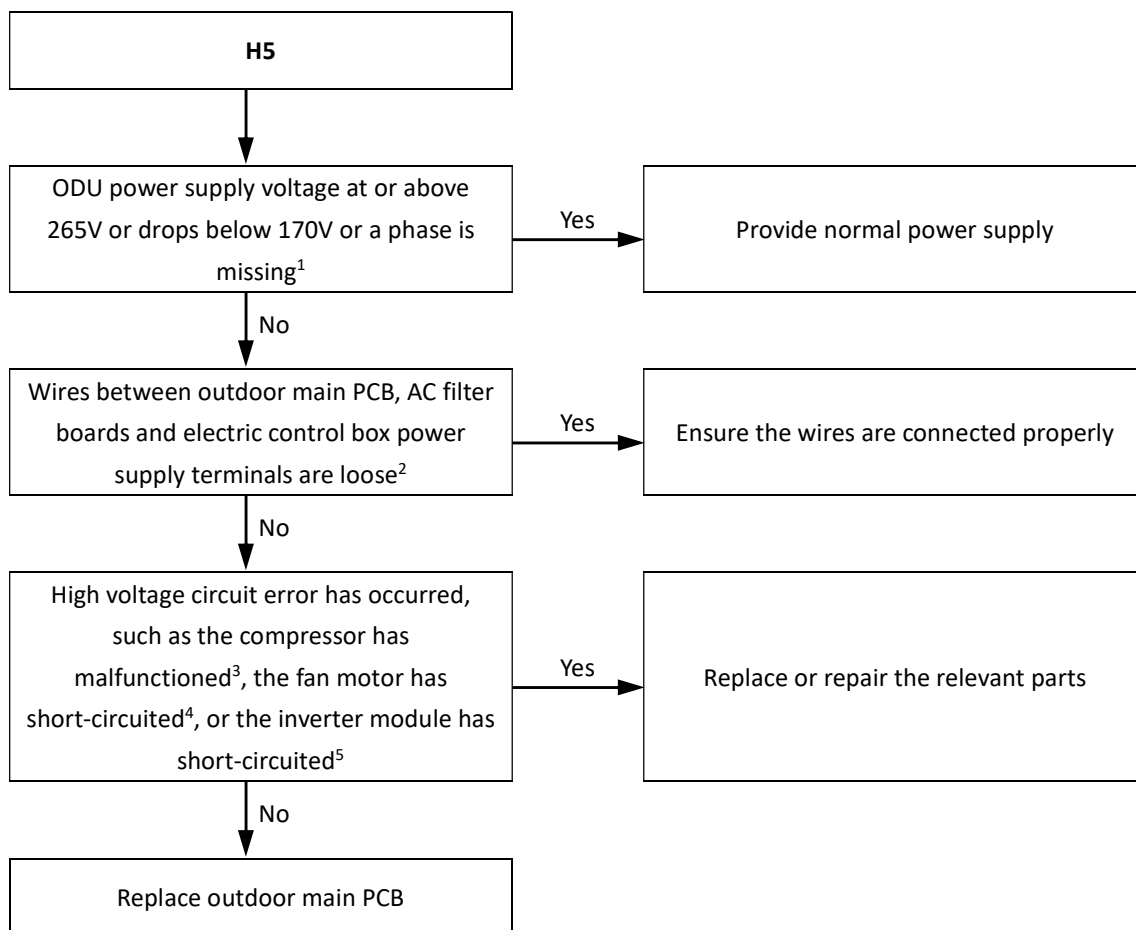

Notes:

1. The normal voltage between A and N, B and N, and C and N is 207-253V.
2. Refer to Part 4, 3 "Wiring diagram" and PCB components to make sure wire connection is firm.
3. The normal resistances of the inverter compressor is 0.124Ω(at 20°C ambient temperature) among U V W and infinite between each of U V W and ground. If any of the resistances differ from these specifications, the compressor has malfunctioned.
4. The normal resistances of the fan motor coil among U V W are less than 15Ω. If a measured resistance is 0Ω, the fan motor has short-circuited.
5. Set a multi-meter to buzzer mode and test any two terminals of P N and U V W of the inverter module. If the buzzer sounds, the inverter module has short-circuited. Refer to Part 4, 1 "Outdoor Unit Electric Control Box Layout".

5.25 F6 Troubleshooting

5.25.1 Digital display output

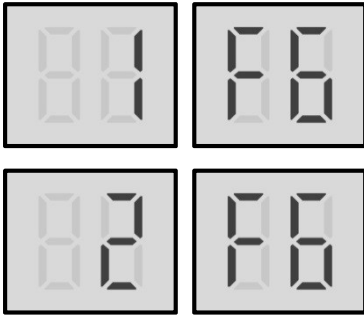

5.25.2 Description

- 1F6 indicates A system buss voltage error (PTC).
- 2F6 indicates B system buss voltage error (PTC).
- Only occurred in standby status.
- Error code is displayed on main PCB and user interface.

5.25.3 Possible causes

- Abnormal power supply voltage
- Loosened wiring within electric control box
- High voltage circuit error
- AC filter board damaged
- 3-phase bridge rectifier damaged
- Compressor Inverter module damaged

5.25.4 Procedure

Refer to P6 protection troubleshooting: xL1 and xL2.

5.26 HE Troubleshooting

5.26.1 Digital display output

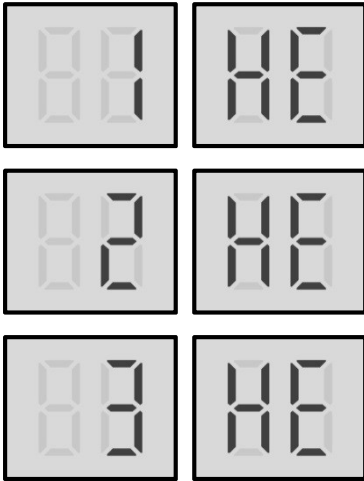

5.26.2 Description

- Electronic expansion valve connection error.
- All units stop running.
- Error code is only displayed on the unit with the error.

5.26.3 Possible causes

- Electronic expansion valve coil not connected properly or has malfunctioned.
- Damaged main PCB.

5.26.4 Procedure

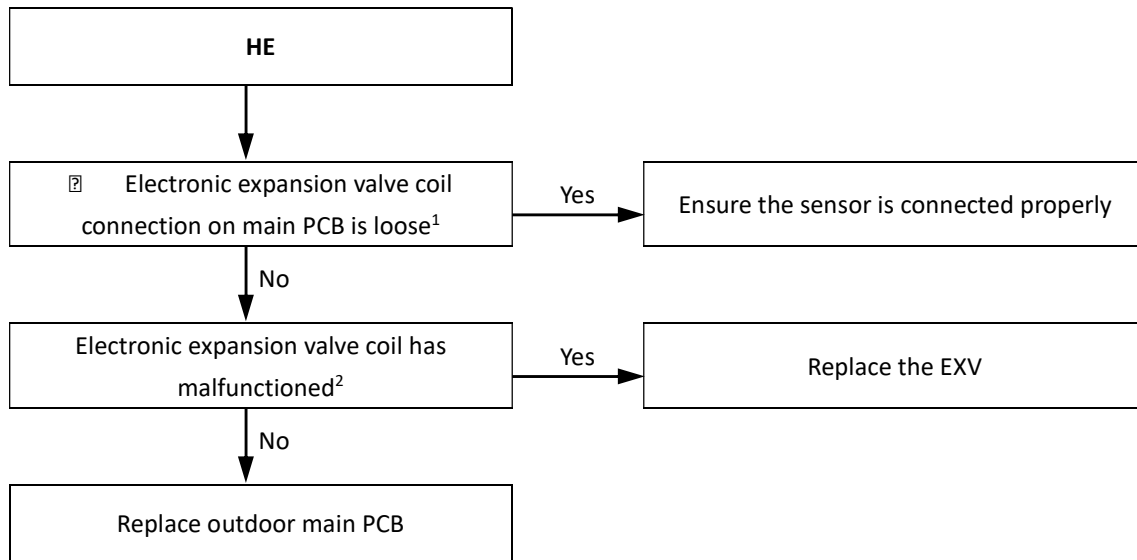

Notes:

1. For SCV-750EB and SCV-1400EB, electronic expansion valve coil connections are port CN70, CN71 and CN72 on the main PCB (labeled 31, 32, 30 in Part 4, 2.2.1 Main PCB component). For SCV-900EB and SCV-1800EB, electronic expansion valve coil connections are port CN70, CN71 and CN72 on the main PCB (labeled 22, 20, 21 in Part 4, 2.2.1 Main PCB component).
2. The normal resistances between EXV coil wiring terminals is 40-50Ω. If any of the resistances differ from the value, the EXV coil has malfunctioned.

5.27 F2 Troubleshooting

5.27.1 Digital display output



5.27.2 Description

- Insufficient protection of exhaust superheat.
- All units stop running.
- Error code is only displayed on main PCB and user interface.

5.27.3 Possible causes

- Discharge pipe temperature sensor connected properly or has malfunctioned.
- For SCV-750EB and SCV-1400EB, discharge pipe temperature sensor at the top of the compressor falls or is not insulated.
For SCV-900EB and SCV-1800EB, electronic expansion valve coil not connected properly or has malfunctioned.
- Damaged main PCB.

5.27.4 Procedure

For SCV-750EB and SCV-1400EB

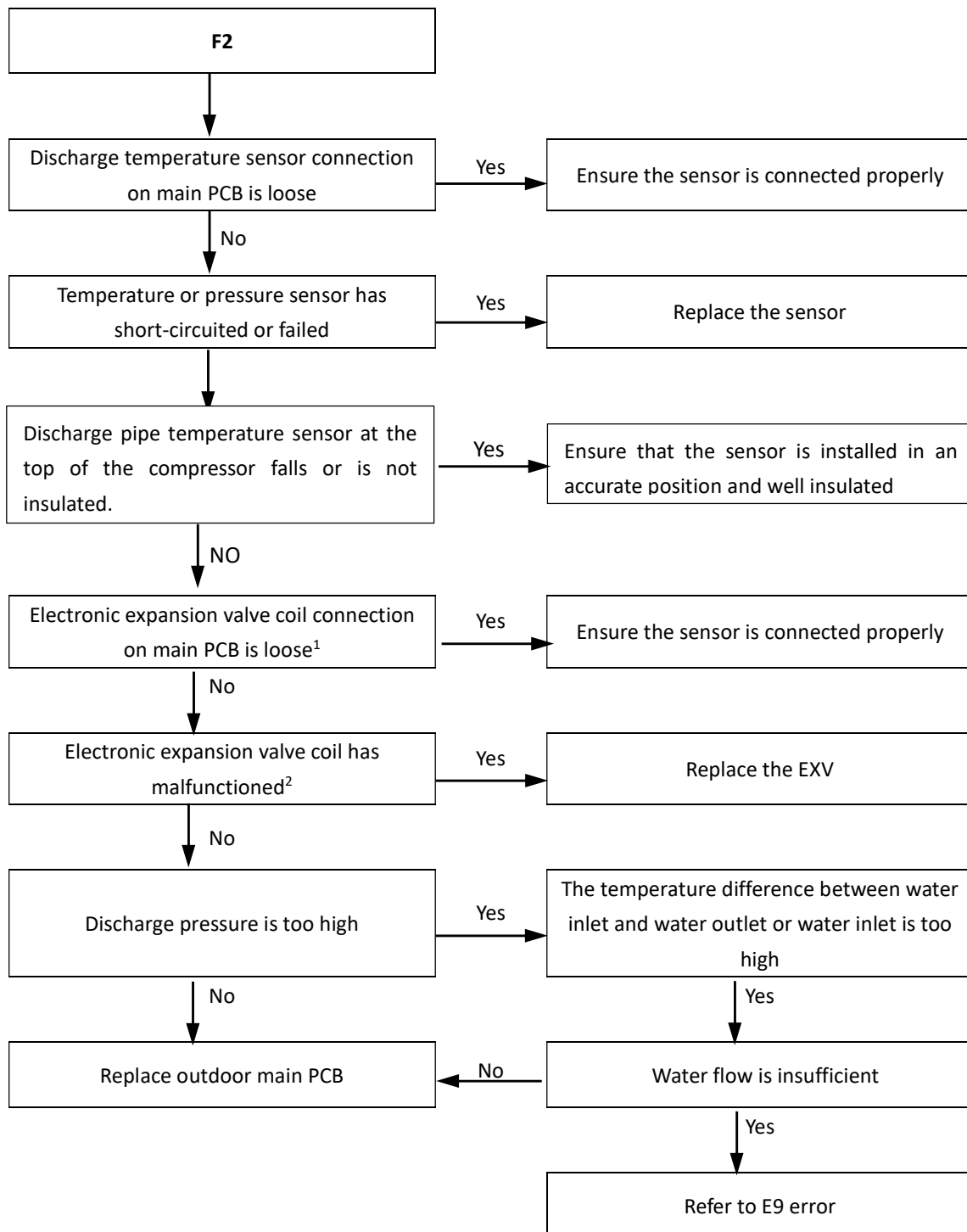

- Notes:
1. Electronic expansion valve coil connections are port CN70, CN71 and CN72 on the main PCB (labeled 31, 32, 30 in Part 4, 2.2.1 Main PCB component).
 2. The normal resistances between EXV coil wiring terminals is 40-50Ω. If any of the resistances differ from the value, the EXV coil has malfunctioned.

For SCV-900EB and SCV-1800EB

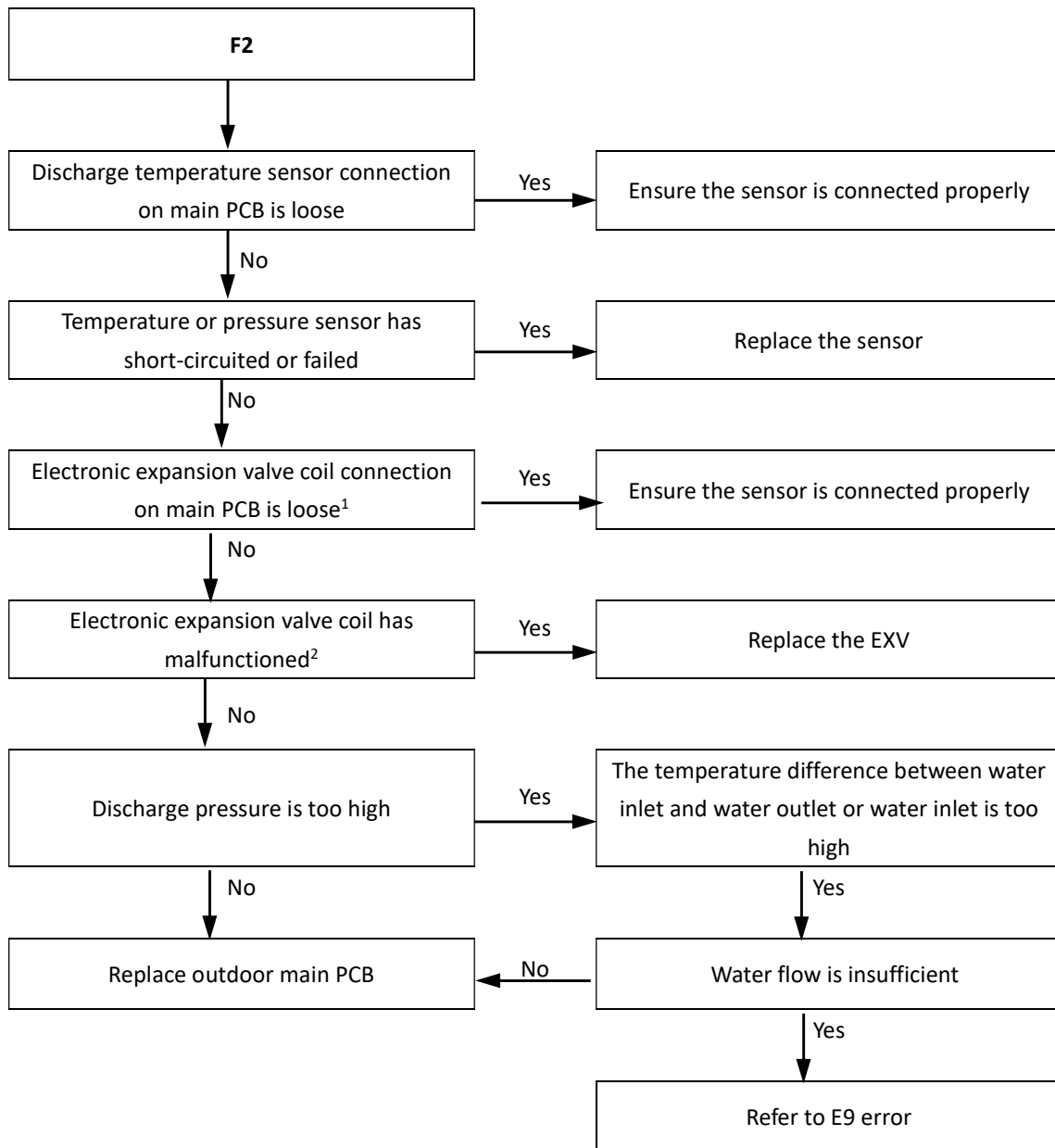

Notes:

1. Electronic expansion valve coil connections are port CN70, CN71 and CN72 on the main PCB (labeled 22, 20,21 in Part 4, 2.2.1 Main PCB component).
2. The normal resistances between EXV coil wiring terminals is 40-50Ω. If any of the resistances differ from the value, the EXV coil has malfunctioned.

5.28 F4 Troubleshooting

5.28.1 Digital display output

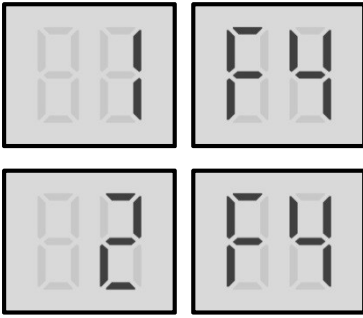

5.28.2 Description

- 1F4 module A L0 or L1 protection occurs for 3 times in 60 minutes.
- 2F4 module B L0 or L1 protection occurs for 3 times in 60 minutes.
- When F4 displays, a manual system restart is required before the system can resume operation.

5.28.3 Possible causes

- Refer to L0 or L1 error troubleshooting.

5.28.4 Procedure

- Refer to L0 or L1 error troubleshooting.

5.29 FP Troubleshooting

5.29.1 Digital display output



5.29.2 Description

- FP indicates pump in a combination system dial to different status. When the FP displayed, a manual system restart is required before the system can resume operation.
- All units stop running.
- Error code is only displayed on main PCB and user interface.

5.29.3 Possible causes

- For SCV-750EB and SCV-1400EB, The S3_1 of slave units is different with the master unit.
For SCV-900EB and SCV-1800EB, the S12_2 of slave units is different with the master unit.
- Main PCB damaged.

5.29.4 Procedure

For SCV-750EB and SCV-1400EB

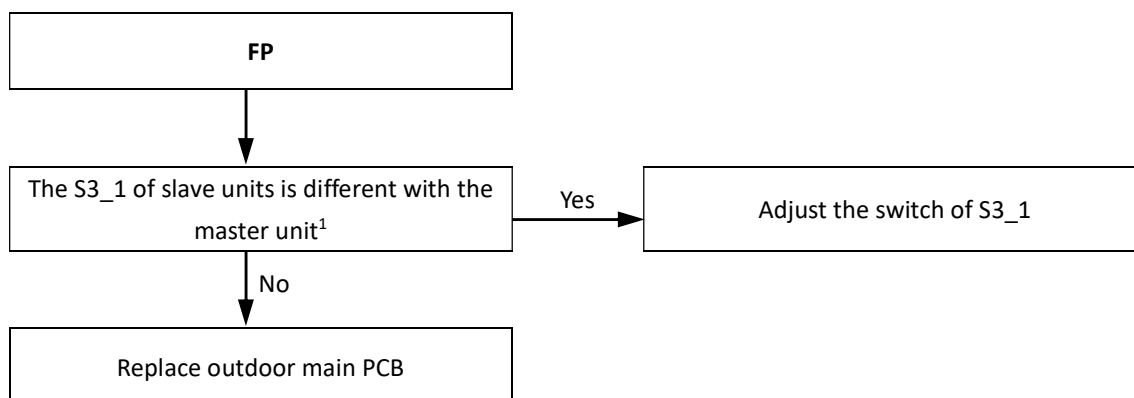

Notes:

1. Dial switch S3_1 on the main PCB

Switch		Description	ON	OFF	Default factory setting
	S3-1	Water pump	Multiple pumps control	Single pump control	OFF

For SCV-900EB and SCV-1800EB

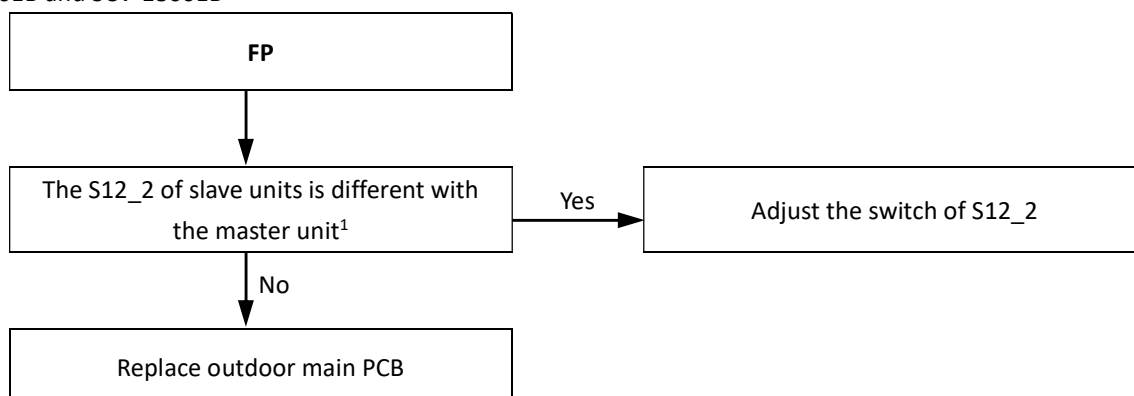

Notes:

2. Dial switch S12_2 on the main PCB

Switch		Description	ON	OFF	Default factory setting
 S12	S12-2	Water pump	Multiple pumps control	Single pump control	OFF

5.30 bH troubleshooting

5.30.1 Digital display output



5.30.2 Description

- bH indicates adhesion of compressor relay or PED board damaged.
- All units stop running.
- Error code is only displayed on main PCB and user interface.

5.30.3 Possible causes

- Power on within 5min after power off
- PED board damaged
- Adhesion of compressor relay
- Compressor module board damaged

5.30.4 Procedure

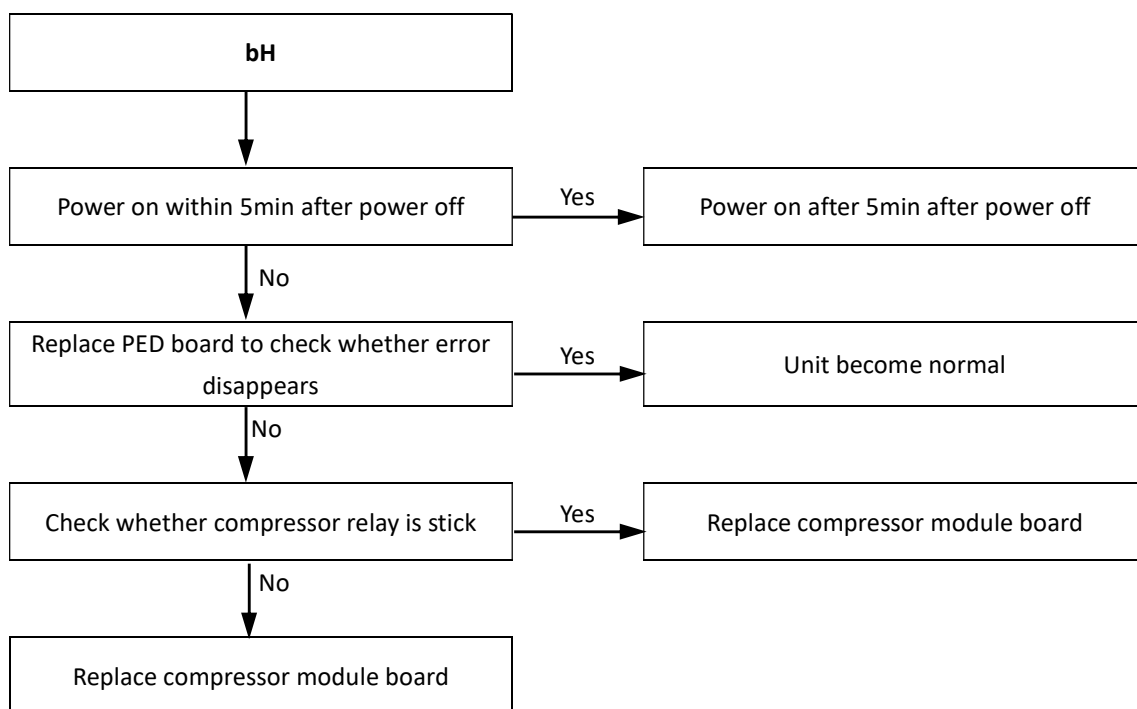

Notes:

3. Dial switch S12_2 on the main PCB

Switch		Description	ON	OFF	Default factory setting
	S12-2	Water pump	Multiple pumps control	Single pump control	OFF

5.31 HC troubleshooting

5.31.1 Digital display output



5.31.2 Description

- HC indicates high pressure sensor error
- All units stop running.
- Error code is only displayed on main PCB and user interface.

5.31.3 Possible causes

- Pressure sensor damaged
- Main control board damaged

5.31.4 Procedure

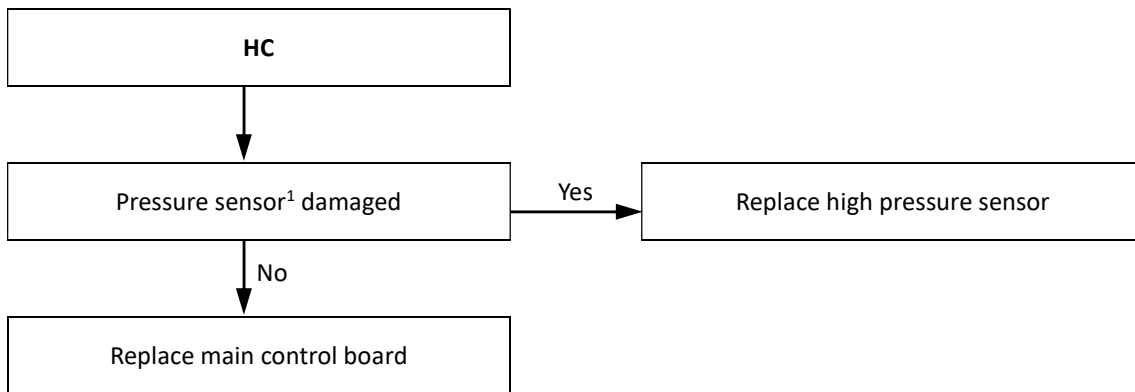

Note:

1. For SCV-750EB and SCV-1400EB, pressure sensor connection is port CN40 on the main PCB (labeled 20 in Part 4, 2.2.1 Main PCB component). Measure the resistance among the three terminals of the pressure sensor. If the resistance is of the order of mega Ohms or infinite, the pressure sensor has failed.
2. For SCV-900EB and SCV-1800EB, pressure sensor connection is port CN16 on the main PCB (labeled 30 in Part 4, 2.2.1 Main PCB component). Measure the resistance among the three terminals of the pressure sensor. If the resistance is of the order of mega Ohms or infinite, the pressure sensor has failed.

5.32 P2 troubleshooting (for SCV-900EB and SCV-1800EB only)

5.32.1 Digital display output



5.32.2 Description

- P2 indicates total cold outlet temperature too high.
- All units stop running.
- Error code is only displayed on main PCB and user interface.

5.32.3 Possible causes

- Temperature sensor damaged
- Main control board damaged

5.32.4 Procedure

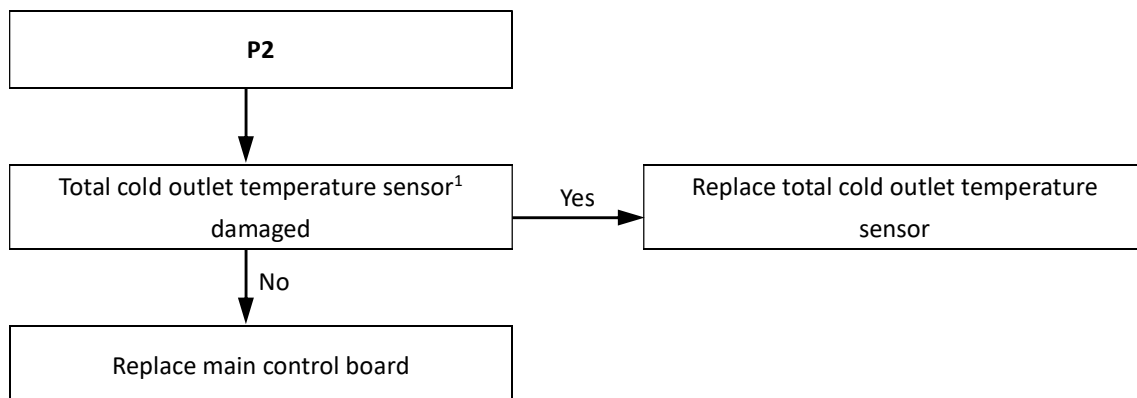

Note:

1. Total cold outlet temperature sensor connection port is CN31 on the main PCB (labeled 31 in Part 4, 2.2.1 Main PCB component). Measure sensor resistance. If the resistance is too low, the sensor has short-circuited. If the resistance is not consistent with the sensor's resistance characteristics table, the sensor has failed. Refer to Part 4, 6.1 "Temperature Sensor Resistance Characteristics".

5.33 P3 troubleshooting

5.33.1 Digital display output



5.33.2 Description

- P3 indicates ambient temperature too high for cooling mode
- All units stop running.
- Error code is only displayed on main PCB and user interface.

5.33.3 Possible causes

- Ambient temperature sensor is interfered by other heat sources and the temperature detection value exceeds 65°C
- Ambient temperature sensor damaged
- Main control board damaged

5.33.4 Procedure

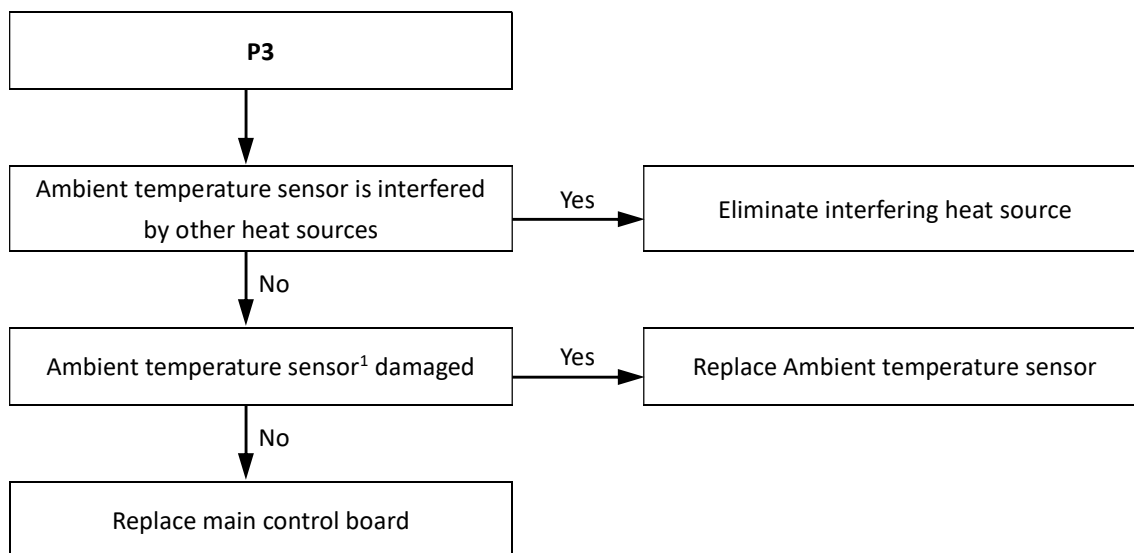

Note:

1. For SCV-750EB and SCV-1400EB, ambient temperature sensor connection port is CN30 on the main PCB (labeled 23 in Part 4, 2.2.1 Main PCB component). Measure sensor resistance. If the resistance is too low, the sensor has short-circuited. If the resistance is not consistent with the sensor's resistance characteristics table, the sensor has failed. Refer to Part 4, 6.1 "Temperature Sensor Resistance Characteristics".
2. For SCV-900EB and SCV-1800EB, ambient temperature sensor connection port is CN1 on the main PCB (labeled 29 in Part 4, 2.2.1 Main PCB component). Measure sensor resistance. If the resistance is too low, the sensor has short-circuited. If the resistance is not consistent with the sensor's resistance characteristics table, the sensor has failed. Refer to Part 4, 6.1 "Temperature Sensor Resistance Characteristics".

5.34 PA troubleshooting

5.34.1 Digital display output



5.34.2 Description

- PA indicates abnormal water inlet and outlet temperature difference protection.
- All units stop running.
- Error code is only displayed on main PCB and user interface.

5.34.3 Possible causes

- Water temperature sensor damaged
- Inlet and outlet water temperature sensor are in the inversely position
- Water flow is too low
- Main control board damaged

5.34.4 Procedure

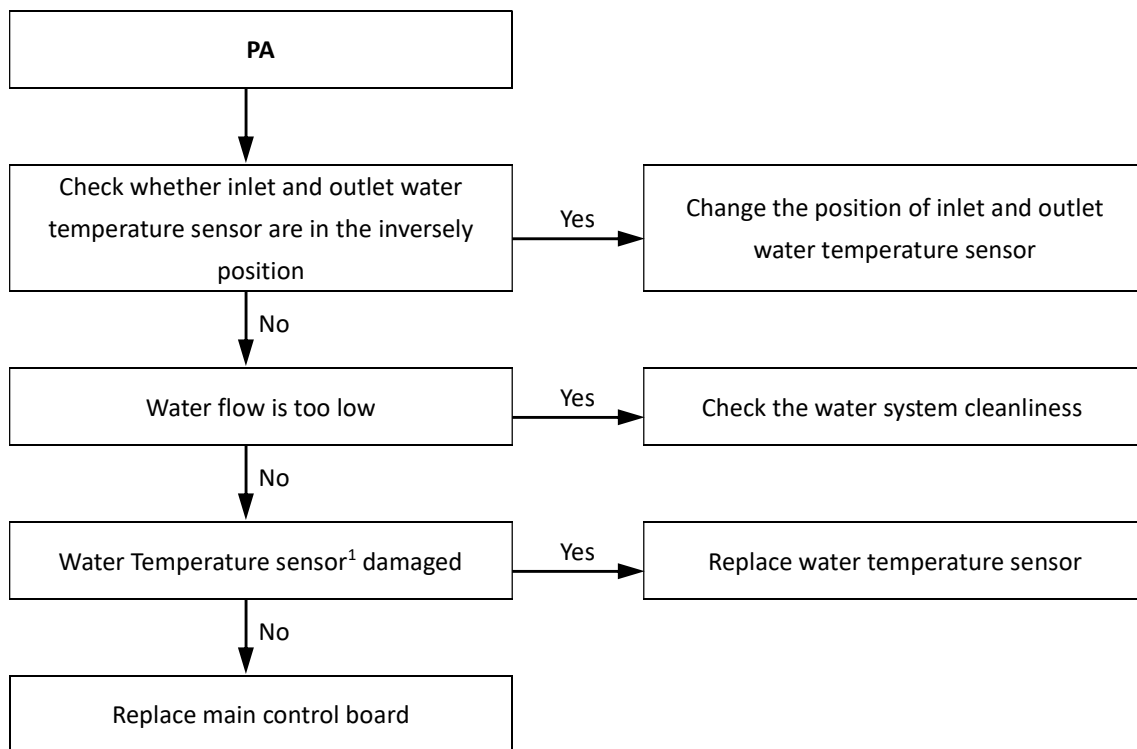

Note:

1. For SCV-750EB and SCV-1400EB, inlet and outlet water temperature sensor connection port is CN4 on the main PCB (labeled 29 in Part 4, 2.2.1 Main PCB component). Measure sensor resistance. If the resistance is too low, the sensor has short-circuited. If the resistance is not consistent with the sensor's resistance characteristics table, the sensor has failed. Refer to Part 4, 6.1 "Temperature Sensor Resistance Characteristics".
2. For SCV-900EB and SCV-1800EB, inlet and outlet water temperature sensor connection port is CN31 on the main PCB (labeled 31 in Part 4, 2.2.1 Main PCB component). Measure sensor resistance. If the resistance is too low, the sensor has short-circuited. If the resistance is not consistent with the sensor's resistance characteristics table, the sensor has failed. Refer to Part 4, 6.1 "Temperature Sensor Resistance Characteristics".

5.35 PC troubleshooting

5.35.1 Digital display output



5.35.2 Description

- PC indicates cooling evaporator pressure too low
- All units stop running.
- Error code is only displayed on main PCB and user interface.

5.35.3 Possible causes

- Evaporator pressure less than 0.6MPa
- Water flow is too low
- Electronic expansion valve damaged
- Pressure sensor damaged
- Main control board damaged

5.35.4 Procedure

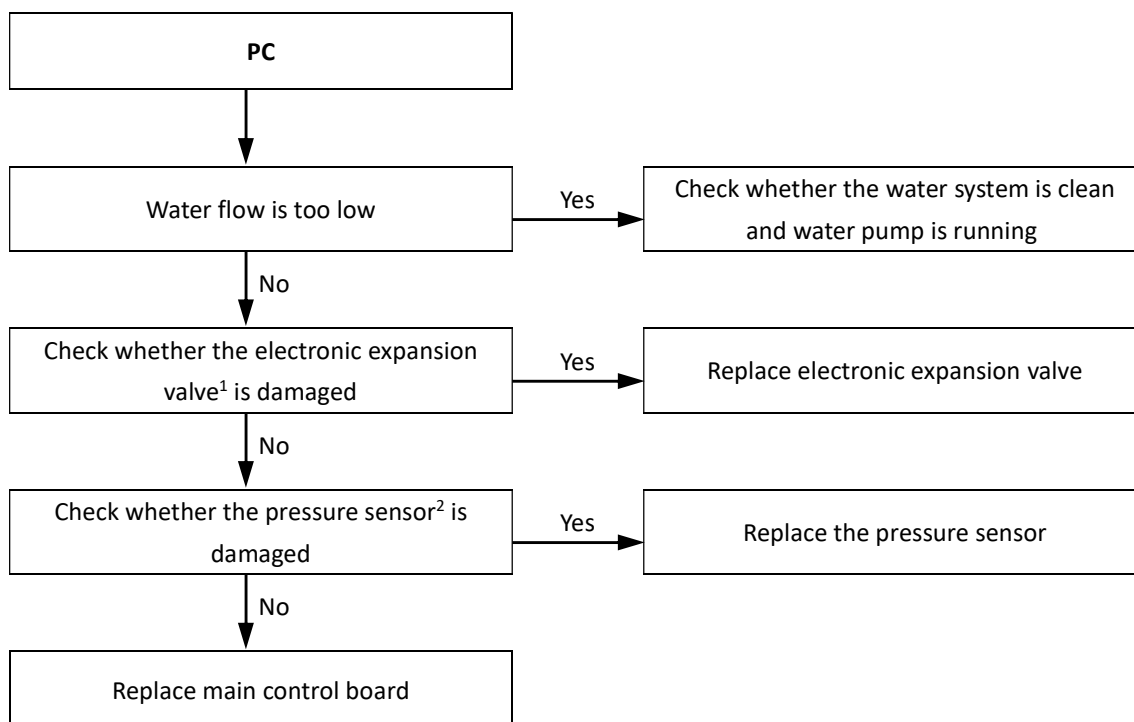

Note:

1. For SCV-750EB and SCV-1400EB, electronic expansion valve coil connections are port CN70, CN71 and CN72 on the main PCB (labeled 31, 32, 30 in Part 4, 2.2.1 Main PCB component). The normal resistances between EXV coil wiring terminals is 40-50Ω. If any of the resistances differ from the value, the EXV coil has malfunctioned.
2. For SCV-900EB and SCV-1800EB, electronic expansion valve coil connections are port CN70, CN71 and CN72 on the main PCB (labeled 22, 20, 21 in Part 4, 2.2.1 Main PCB component). The normal resistances between EXV coil wiring terminals is 40-50Ω. If any of the resistances differ from the value, the EXV coil has malfunctioned.
3. For SCV-750EB and SCV-1400EB, pressure sensor connection is port CN41 on the main PCB (labeled 19 in Part 4, 2.2.1 Main PCB component). Measure the resistance among the three terminals of the pressure sensor. If the resistance is of the order of mega Ohms or infinite, the pressure sensor has failed.
4. For SCV-900EB and SCV-1800EB, pressure sensor connection is port CN16 on the main PCB (labeled 30 in Part 4, 2.2.1 Main PCB component). Measure the resistance among the three terminals of the pressure sensor. If the resistance is of the order of mega Ohms or infinite, the pressure sensor has failed.

6 Drive Module Failure

(For SCV-750EB and SCV-1400EB only)

6.1 Error code table

Error code	Content	Error category	Need to power on again
L10	Overcurrent protection	Overcurrent fault	NO
L11	Transient phase current overcurrent protection		NO
L12	Phase current overcurrent lasts 30s protection		NO
L20	Module over temperature protection	Over temperature fault	NO
L30	Low bus voltage error	Power fault	NO
L31	High bus voltage error		NO
L32	Excessively high bus voltage error		NO
L34	Phase loss error		NO
L43	Abnormal phase current sampling bias	hardware fault	NO
L45	Motor code not match		YES
L46	IPM protection (FO)		NO
L47	Module type not match (After module resistance detection)		YES
L50	Startup failure	Control fault	NO
L51	Out of step error (Reserved)		NO
L52	Zero speed protection		NO
L60	Fan motor phase loss protection	Diagnostic fault	NO
L65	IPM short circuit error		NO
L66	FCT detection error		NO
L6A	Open circuit of U-phase upper tube		NO
L6b	Open circuit of U-phase lower tube		NO
L6C	Open circuit of V-phase upper tube		NO
L6d	Open circuit of V-phase lower tube		NO
L6E	Open circuit of W-phase upper tube		NO
L6F	Open circuit of W-phase lower tube	NO	
Lb0	High pressure switch motion	Authentication fault	NO
Lb1	Relay adhesion (Reserved)		NO
Lb2	RAM check error (Reserved)		NO
Lb3	ROM check error (Reserved)		NO
Lb4	Register or ALU check error (Reserved)		NO
Lb5	Stack over flow check error (Reserved)		NO
Lb6	Program stream check error (Reserved)		NO
Lb7	Other abnormal check /PED diagnostic errors		NO
Lb8	PED 5V abnormal (Reserved)		NO

6.2 L10: Hardware overcurrent

6.2.1 Description

- The current exceeds the OCP protection value (peak value) set by the hardware or receives the FO signal from the IPM module.
- After the fault, the compressor stops running. If the fault disappears after one minute, the compressor starts again.

6.2.2 Trigger/resume condition

- The current reaches the OCP protection value

Trigger condition: The current reaches the OCP protection value.

Resume condition: The compressor shuts down after a fault, and resumes after reaching the fault exit condition one minute later.

Reset method: Automatic recovery after reaching the fault exit condition one minute later.

- A falling edge or continuously low level of the FO signal is detected:

Trigger condition: The falling edge or continuously low electrical level of the FO signal is detected.

Recovery Condition: The FO signal turns into high level.

Reset method: Automatic recovery after reaching the fault exit condition one minute later.

6.2.3 Possible causes

- There are impurities in the refrigerant system or the compressor is momentarily stuck, causing the current surge to trigger OCP;
- The compressor winding is short-circuited between phases, resulting in instantaneous high current to trigger OCP or FO;
- The voltage of the system power supply drops or is interrupted for a short time, resulting in an instantaneous surge of current to trigger OCP;
- Condensation of the IPM module leads to a short circuit between the control pins;
- System backflow;
- The rotor has a certain speed when the compressor is started (commonly when a compressor has been started or the main engine has been started, and the refrigerant drives the rotor of the compressor that is about to start when the four-way valve is reversed);
- The abnormality of the module board (Idc, OCP comparison circuit, PWM circuit, IPM, IGBT drive power circuit) causes the control to lose step and generate a large current to trigger the OCP.

6.2.4 Procedure

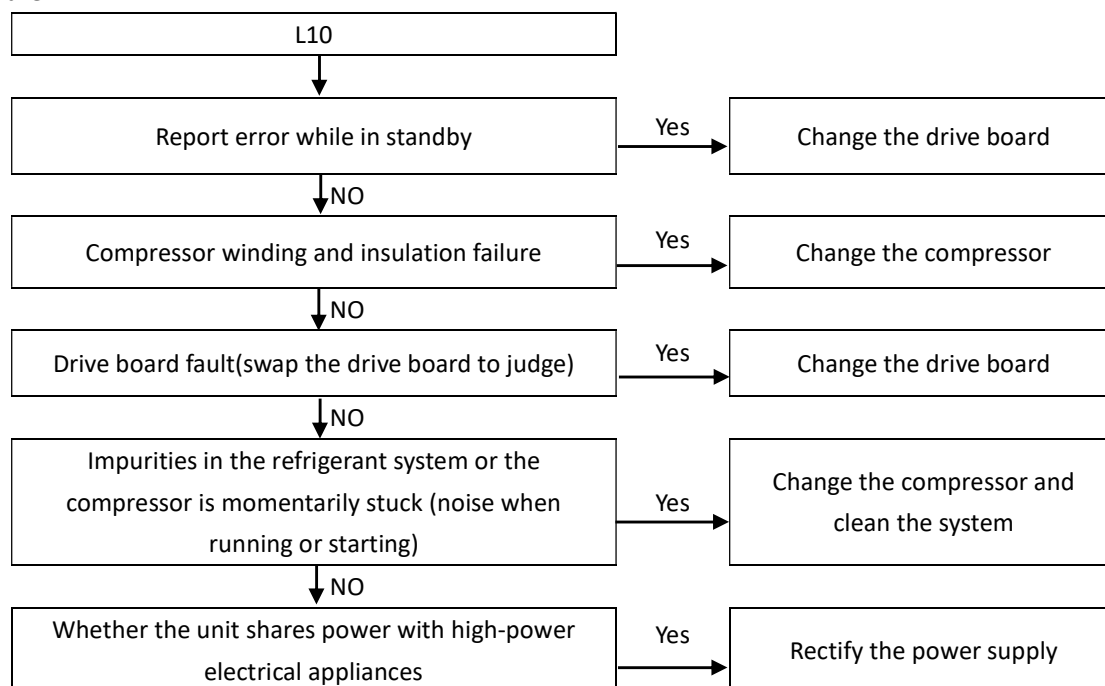

6.3 L11: Software overcurrent

6.3.1 Description

- The current exceeds the OCP protection value (peak value) set by the software;
- After the fault, the compressor stops running. If the fault disappears after one minute, the compressor starts again.

6.3.2 Trigger/resume condition

- Trigger condition: It is detected that the compressor current exceeds the OCP protection value set by the software for three consecutive carrier cycles.
- Resume condition: The compressor shuts down after a fault, and resumes after reaching the fault exit condition one minute later.
- Reset method: Automatic recovery after reaching the fault exit condition one minute later.

6.3.3 Possible causes

- There are impurities in the refrigerant system or the compressor is momentarily stuck, causing the current surge to trigger OCP;
- Module board lcd op amp sampling circuit is abnormal.

6.3.4 Procedure

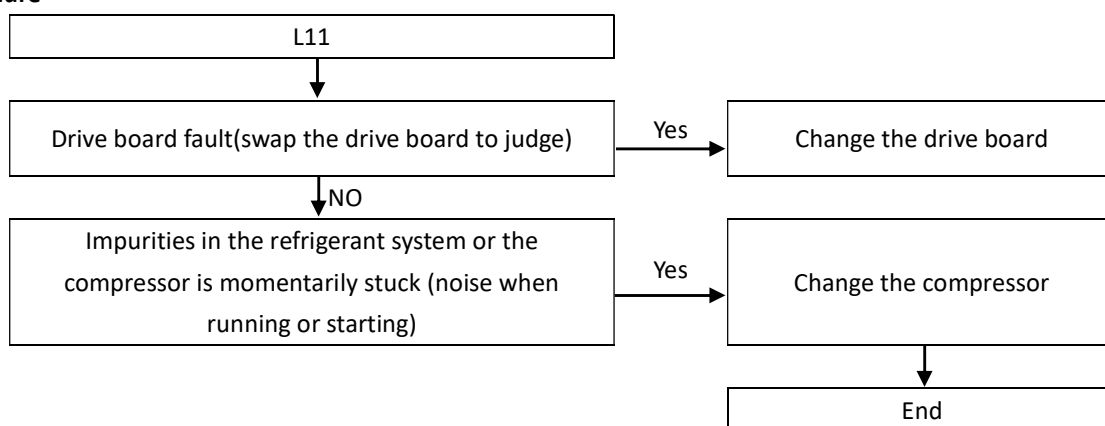

6.4 L20: Module overheat protection

6.4.1 Description

- IPM module temperature exceeds 105 °C.
- After the fault, the compressor stops running, and if the fault disappears after one minute, the compressor starts again.

6.4.2 Trigger/resume condition

- Trigger condition: IPM module temperature exceeds 105 °C;
- Resume condition: The compressor shuts down after a fault, and resumes after reaching the fault exit condition (The module temperature is lower than 105 °C) one minute later;
- Reset method: Automatic recovery after reaching the fault exit condition one minute later.

6.4.3 Possible causes

- IPM fixing screws are not tightened, resulting in poor heat dissipation;
- The heat dissipation silicone of the IPM module is not evenly spread, resulting in poor heat dissipation;
- The system lacks refrigerant or the refrigerant radiator pipeline is blocked, resulting in poor heat dissipation of the refrigerant radiator;
- The system refrigerant radiator is abnormally welded, resulting in too large thermal resistance and poor heat dissipation;
- The module board IPM temperature detection circuit is abnormal.

6.4.4 Procedure

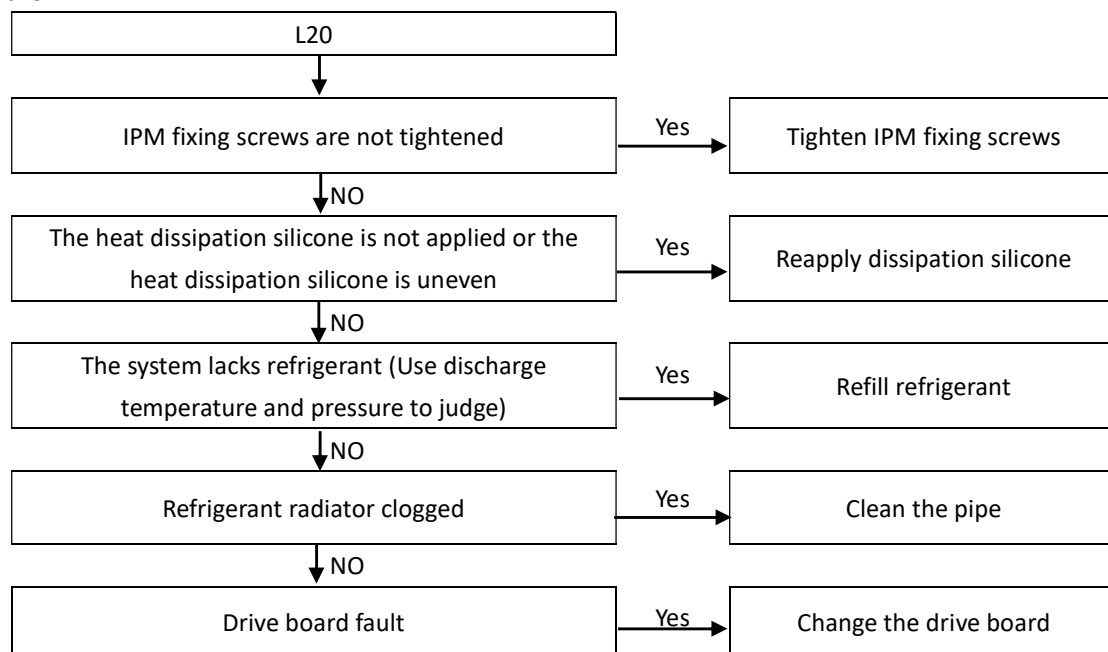

6.5 L30: Low bus voltage protection

6.5.1 Description

- The bus voltage is lower than the low bus voltage protection threshold (350VDC) set by the software.
- After the fault, the compressor stops running, and if the fault disappears after one minute, the compressor starts again.

6.5.2 Trigger/resume condition

- Trigger condition: The bus voltage is lower than the low bus voltage protection threshold (350VDC) set by the software.
- Resume condition: The compressor shuts down after a fault, and resumes after reaching the fault exit condition (The bus voltage is higher than the low bus voltage protection threshold (350VDC) (set by the software.) one minute later.
- Reset method: Automatic recovery after reaching the fault exit condition one minute later.

6.5.3 Possible causes

The input voltage is too low, resulting in low bus voltage;

The voltage drop and interrupt, resulting in the low instantaneous bus voltage;

The module board bus voltage detection circuit is abnormal.

6.5.4 Procedure

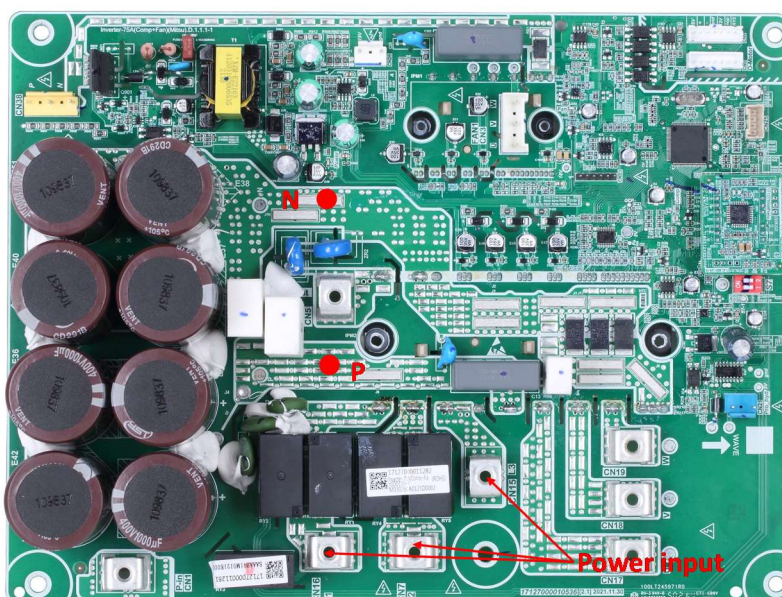
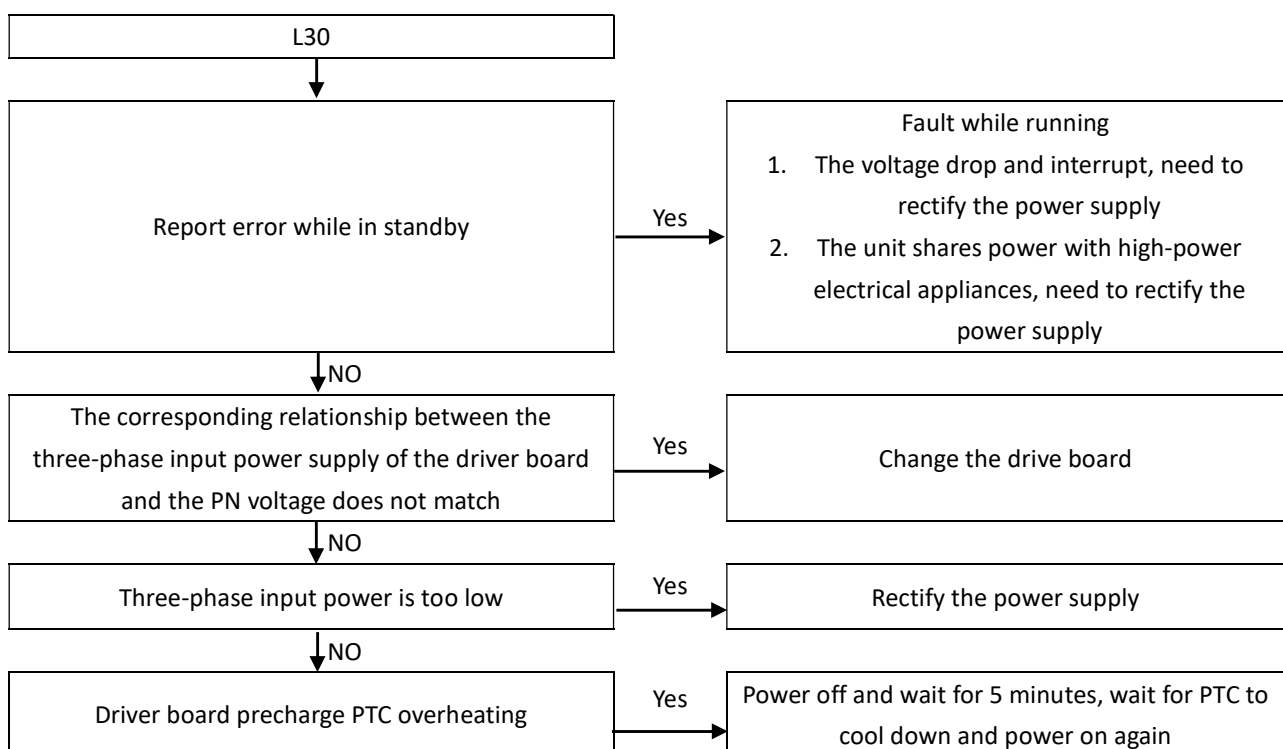

6.6 L31: High bus voltage error

6.6.1 Description

- The bus voltage is higher than the high bus voltage protection threshold (750VDC) set by the software.
- After the fault, the compressor stops running, and if the fault disappears after one minute, the compressor starts again.

6.6.2 Trigger/resume condition

- Trigger condition: The bus voltage is higher than the high bus voltage protection threshold set by the software.
- Resume condition: The compressor shuts down after a fault, and resumes after reaching the fault exit condition (The bus voltage is lower than the high bus voltage protection threshold set by the software.) one minute later.
- Reset method: Automatic recovery after reaching the fault exit condition one minute later.

6.6.3 Possible causes

- The input voltage is too high, resulting in high bus voltage;
- The grid voltage is abnormally high instantaneously.
- The module board bus voltage detection circuit is abnormal.

6.6.4 Procedure

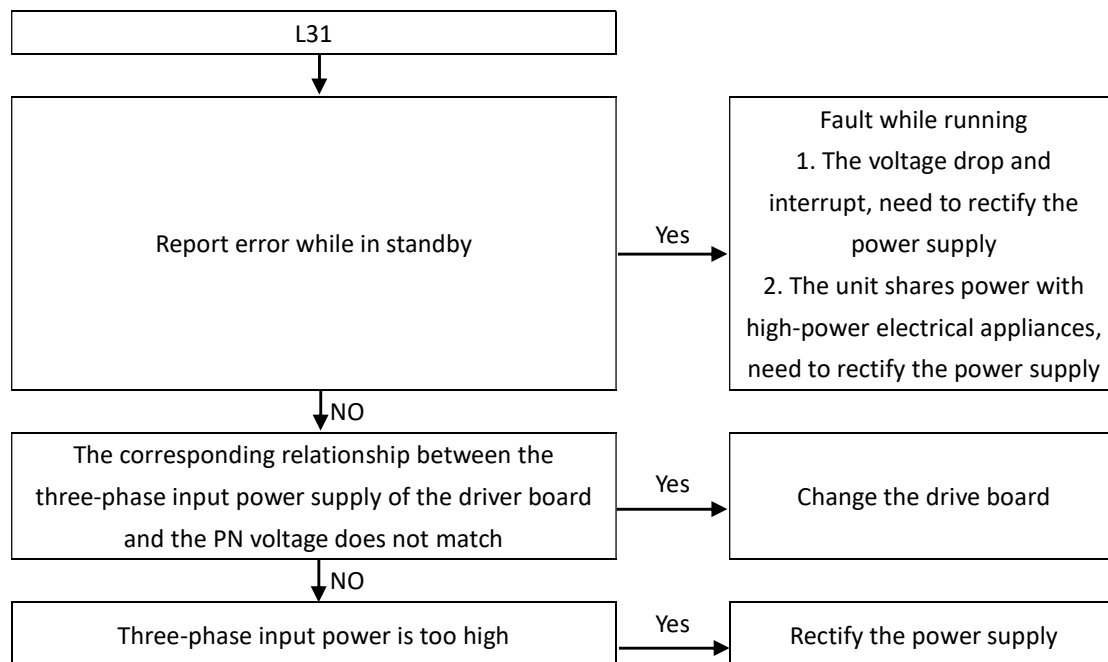

6.7 L32: Excessively high bus voltage error

6.7.1 Description

- The bus voltage is higher than the excessively high bus voltage protection threshold (770VDC) set by the software.
- After the fault, the compressor stops running, and if the fault disappears after one minute, the compressor starts again.

6.7.2 Trigger/resume condition

- Trigger condition: The bus voltage is higher than the excessively high bus voltage protection threshold set by the software.
- Resume condition: The compressor shuts down after a fault, and resumes after reaching the fault exit condition (The bus voltage is lower than the excessively high bus voltage protection threshold set by the software.) one minute later.
- Reset method: Automatic recovery after reaching the fault exit condition one minute later.

6.7.3 Possible causes

- The input voltage is too high, resulting in high bus voltage;
- The grid voltage is abnormally high instantaneously
- The module board bus voltage detection circuit is abnormal.

6.7.4 Procedure

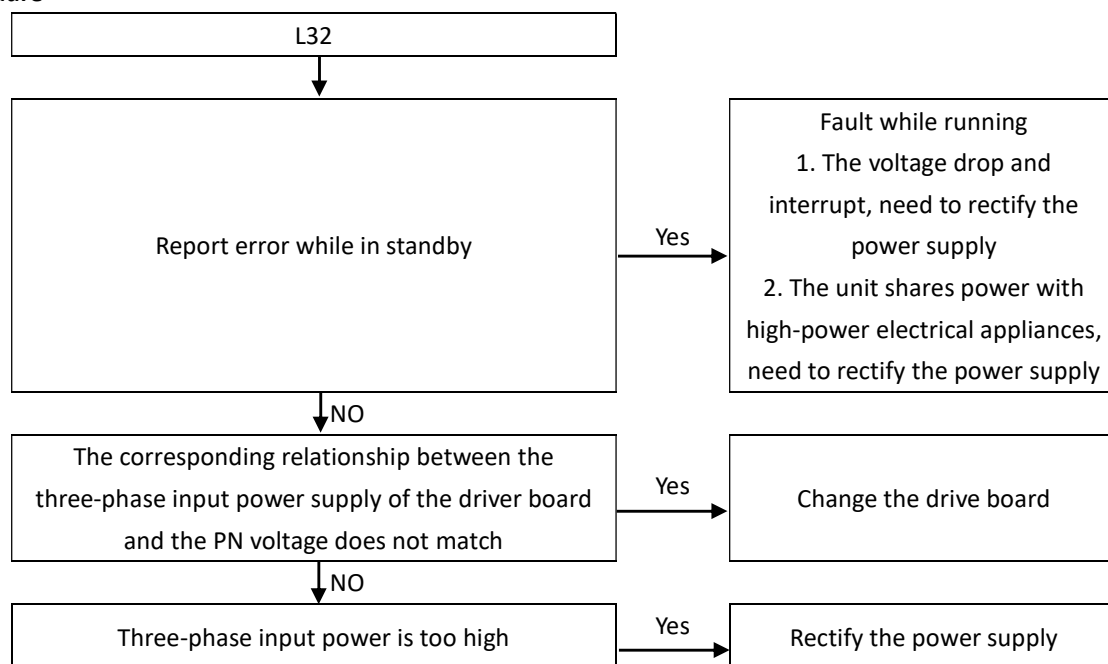

6.8 L34: Phase loss error

6.8.1 Description

- The power input phase is missing or the three-phase power supply is seriously unbalanced.
- After the fault, the compressor stops running, and if the fault disappears after one minute, the compressor starts again.

6.8.2 Trigger/resume condition

- Trigger condition: The power input phase is missing or the three-phase power supply is seriously unbalanced.
- Resume condition: Detect the factors that cause the phase loss, such as poor power input wiring or the screw of the terminal is not tightened, or disconnect other electrical equipment that shares the power supply with the unit.
- Reset method: Automatic recovery after reaching the fault exit condition one minute later.

6.8.3 Possible causes

- Abnormal system power wiring leads to phase loss, or the N line and the phase line are reversed;
- The system power cord is poorly wired or the screws are not tightened;
- The module board is abnormal (one-phase relay is not operating);
- There is a large load on one or two phases of the system power supply, resulting in an unbalanced supply voltage;
- The power distribution phase unbalance degree exceeds 3% (phase angle unbalance, or three-phase voltage unbalance, or both).

6.8.4 Procedure

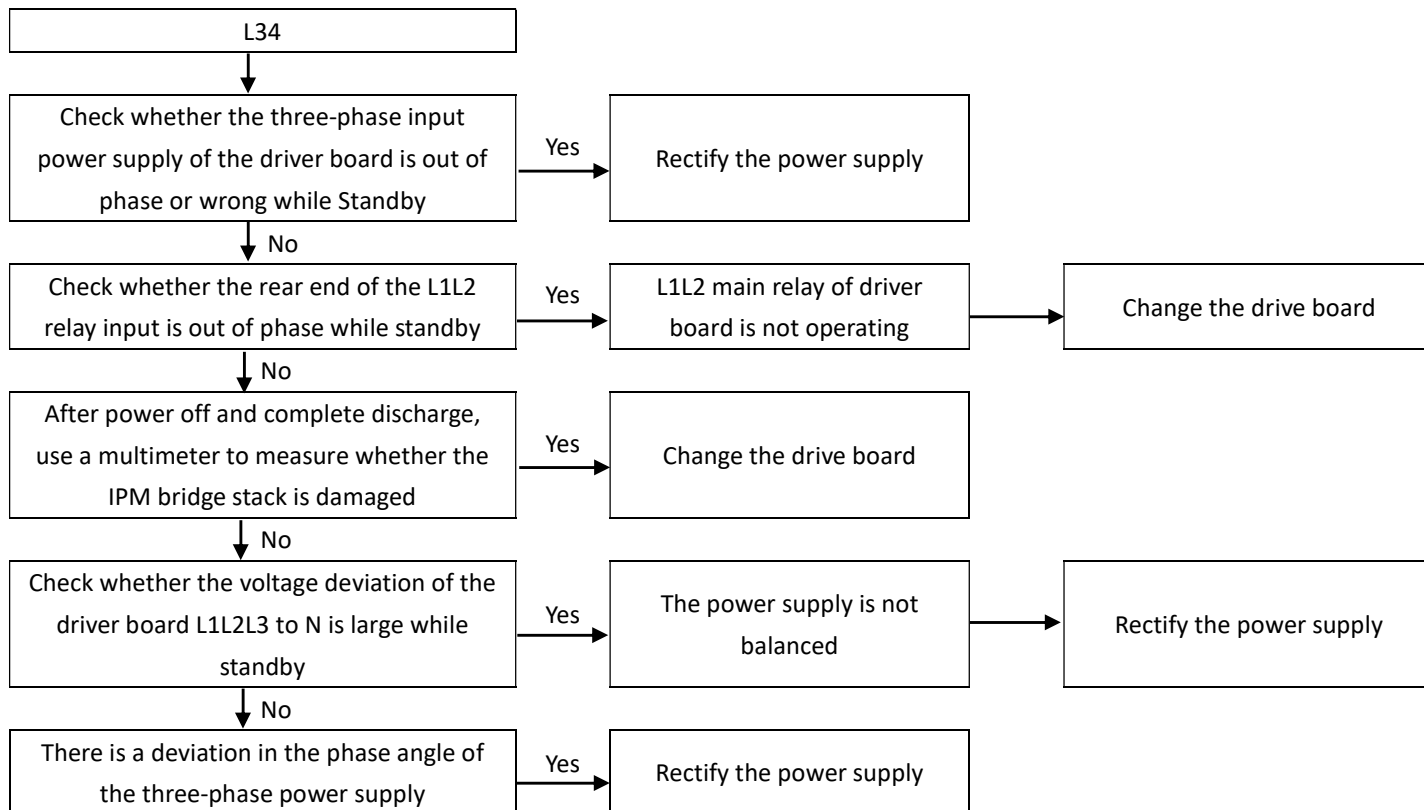

6.9 L45: Abnormal current sampling circuit bias

6.9.1 Description

- The current sampling circuit calibration has failed.
- After this fault occurs, the compressor cannot be started. It is necessary to check whether there is a problem with the drive board.

6.9.2 Trigger/resume condition

- Trigger condition: The AD offset value of the current sampling circuit reaches half of the AD full scale.
- Resume condition: After this fault occurs, the compressor cannot be started. It is necessary to check whether there is a problem with the drive board. After that, the AD bias value of the current sampling circuit is less than half of the AD full scale when the power is turned on again. Then this fault will not occur again.
- Reset method: Automatic recovery after reaching the fault exit condition one minute later.

6.9.3 Possible causes

- There is a problem with sampling circuit of the driver board.

6.9.4 Procedure

- Change the driver board.

6.10 Motor code not match

6.10.1 Description

- Parameters do not match.
- After this fault occurs, the compressor cannot be started. It is necessary to check whether there is a problem with the drive board.

6.10.2 Trigger/resume condition

- Trigger condition: The compressor model selected by the master through communication does not match the compressor drive parameters in the drive.
- Resume condition: Check whether the dial code of the model is wrongly dialed, and re-select the dial code of the corresponding model.
- Reset method: Re-select the dial code of the corresponding model, then power off and restart.

6.10.3 Possible causes

- The main controller's capacity dial or model dial is set incorrectly;
- The matching model of the module board is incorrectly selected;
- The main board circuit or the module board circuit is abnormal.

6.10.4 Procedure

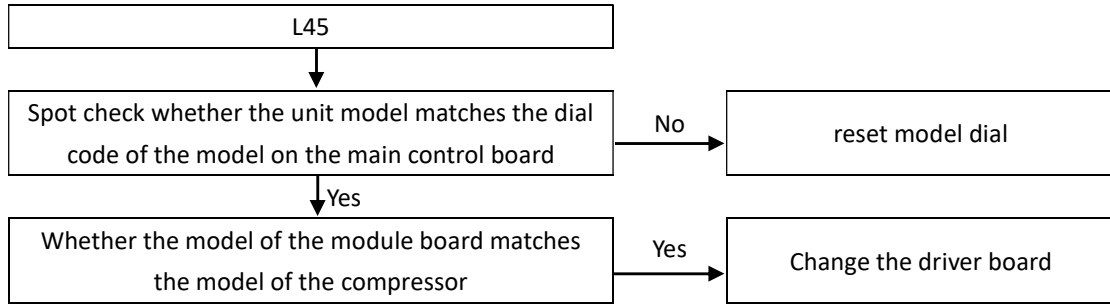

6.11 L46: IPM protection (FO)

6.11.1 Description

- The FO signal of the IPM module has a falling edge or a continuous low level.
- After the fault, the compressor stops running, and if the fault disappears after one minute, the compressor starts again.

6.11.2 Trigger/resume condition

- Trigger condition: The FO signal of the IPM module has a falling edge or a continuous low level.
- Resume condition: The FO signal of the IPM module turns into high level.
- Reset method: Automatic recovery after reaching the fault exit condition one minute later.

6.11.3 Possible causes

- Internal short circuit of the IPM module;
- Short circuit of compressor winding;
- System condensation results in short circuit of IPM module pins;
- The drive voltage of the lower bridge IGBT of the IPM module is lower than 10.3V;
- The module board is abnormal.

6.11.4 Procedure

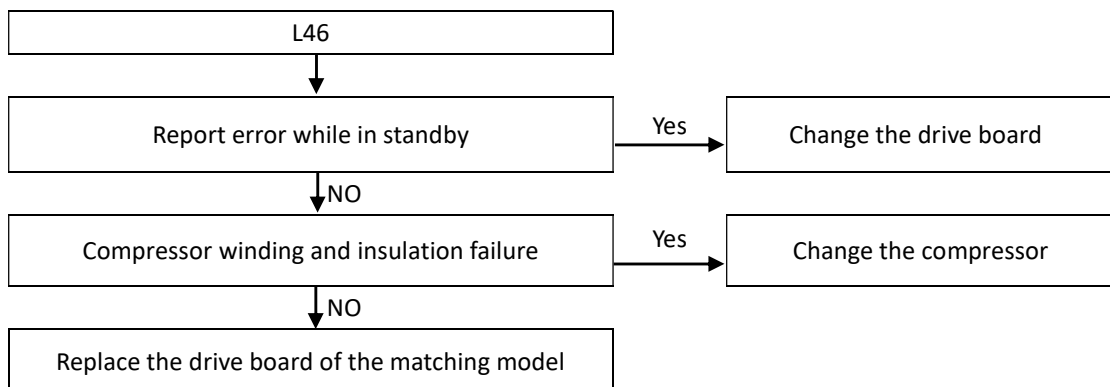

6.12 L47: Module type not match

6.12.1 Description

- The driver board detected by the module detection resistor does not match the setting in the driver parameter table.

6.12.2 Trigger/resume condition

- Trigger condition: The current level of the drive board and the compressor information detected by the module detection resistor do not match the settings in the drive parameter table.
- Resume condition: Change the module board.
- Reset method: Re-select the module board corresponding to the model, then power off and restart.

6.12.3 Possible causes

- The main control capacity dial code and model selection are wrong;

- Wrong module board which does not correspond to the model;
- Module board fault.

6.12.4 Procedure

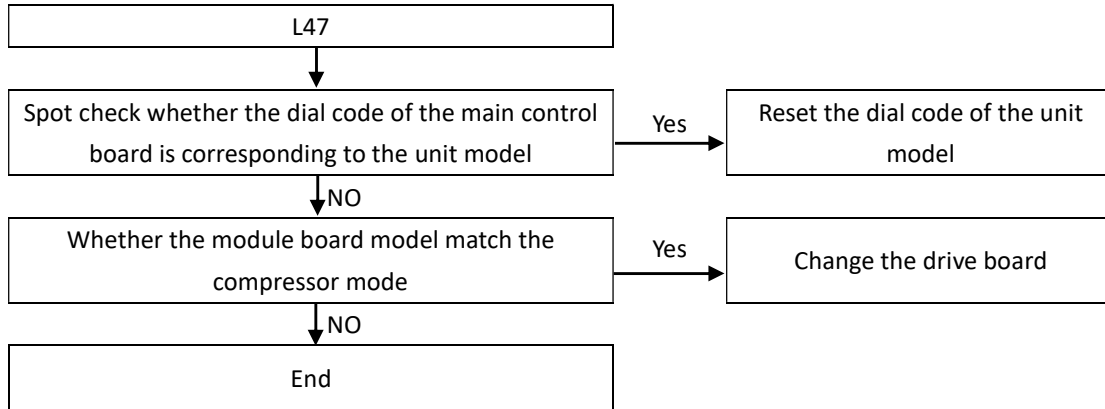

6.13 L50: Startup failure

6.13.1 Description

- Compressor failed to start.
- After the fault, the compressor stops running, and if the fault disappears after one minute, the compressor starts again.

6.13.2 Trigger/resume condition

- Trigger condition: Compressor failed to start.
- Resume condition: After the compressor fails to start, the compressor restarts again. The fault is recovered after successful restart.
- Reset method: Automatic recovery after successful restart.

6.13.3 Possible causes

- There is a pressure difference when the system starts;
- Compressor stuck.

6.13.4 Procedure

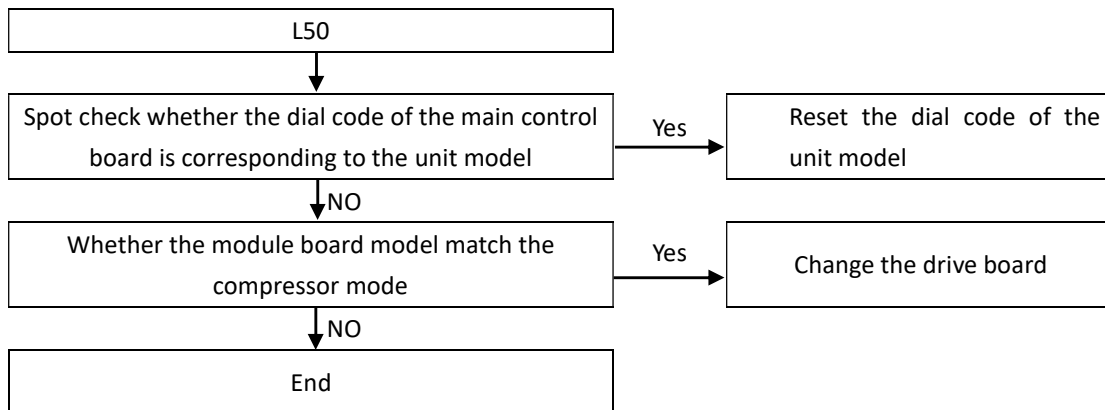

6.14 L52: Zero speed protection

6.14.1 Description

- Compressor locks rotor.
- After the fault, the compressor stops running, and if the fault disappears after one minute, the compressor starts again.

6.14.2 Trigger/resume condition

- Trigger condition: Compressor locks rotor.
- Resume condition: Troubleshoot locked rotor.
- Reset method: Automatic recovery after reaching the fault exit condition.

6.14.3 Possible causes

- Impurities in the system or lack of lubricating oil.

6.14.4 Procedure

If possible, switch the compressors and start up again. If the problem persists, replace the two compressors.

6.15 L60: Fan motor phase loss protection

6.15.1 Description

- Compressor has phase loss protection.
- After the fault, the compressor stops running, and if the fault disappears after one minute, the compressor starts again.

6.15.2 Trigger/resume condition

- Trigger condition: The compressor wire is not connected or has poor contact.
- Resume condition: Check the wiring of the compressor. After wiring again, the phase loss protection fault is eliminated.
- Reset method: Automatic recovery after reaching the fault exit condition.

6.15.3 Possible causes

- The compressor wire is not in good contact or the terminal screws are not tightened.
- Module board is abnormal.

6.15.4 Procedure

- Check the UVW output connection wire of the compressor drive board, and check the UVW wiring of the compressor;
- If possible, switch the compressor wire to confirm whether the drive board is normal, otherwise replace the drive board.

6.16 L61: Short circuit to ground protection

6.16.1 Description

- Compressor has short circuit to ground protection.
- After the fault, the compressor stops running, and if the fault disappears after one minute, the compressor starts again.

6.16.2 Trigger/resume condition

- Trigger condition: Compressor has short circuit to ground protection.
- Resume condition: Check whether the compressor casing is damaged, resulting in poor insulation.
- Reset method: Automatic recovery after reaching the fault exit condition.

6.16.3 Possible causes

- The compressor casing is in poor insulation.

6.16.4 Procedure

- Disconnect the compressor wire, measure the compressor UVW resistance to ground, confirm and replace the compressor.

6.17 L65: IPM short circuit protection

6.17.1 Description

- The IPM corresponding to the compressor has short circuit protection.
- After the fault, the compressor stops running, and if the fault disappears after one minute, the compressor starts again.

6.17.2 Trigger/resume condition

- Trigger condition: The IPM corresponding to the compressor has short circuit protection.
- Resume condition: Replace the drive board.
- Reset method: Automatic recovery after reaching the fault exit condition.

6.17.3 Possible causes

- There is a problem with drive board.

6.17.4 Procedure

- Check whether the IPM virtual welding and the PWM related transmission circuit of the MCU are connected to the welding. If so, change the replace the drive board.

6.18 L6b: Open circuit of U-phase lower tube

6.18.1 Description

- Open circuit of U-phase lower tube.
- After the fault, the compressor stops running, and if the fault disappears after one minute, the compressor starts again.

6.18.2 Trigger/resume condition

- Trigger condition: Open circuit of U-phase lower tube corresponding to compressor.
- Resume condition: Check whether the IPM module is working.
- Reset method: Change the module board. Power on and start up again.

6.18.3 Possible causes

- There IPM module is damaged.

6.18.4 Procedure

- Check whether the IPM virtual welding and the PWM related transmission circuit of the MCU are connected to the welding. If so, change the replace the drive board.

6.19 L6c: Open circuit of V-phase upper tube

6.19.1 Description

- Open circuit of V-phase upper tube.
- After the fault, the compressor stops running, and if the fault disappears after one minute, the compressor starts again.

6.19.2 Trigger/resume condition

- Trigger condition: Open circuit of V-phase upper tube corresponding to compressor.
- Resume condition: Check whether the IPM module is working.
- Reset method: Change the module board. Power on and start up again.

6.19.3 Possible causes

- There IPM module is damaged.

6.19.4 Procedure

- Check whether the IPM virtual welding and the PWM related transmission circuit of the MCU are connected to the welding. If so, change the replace the drive board.

6.20 L6d: Open circuit of V-phase lower tube

6.20.1 Description

- Open circuit of V-phase lower tube.
- After the fault, the compressor stops running, and if the fault disappears after one minute, the compressor starts again.

6.20.2 Trigger/resume condition

- Trigger condition: Open circuit of V-phase lower tube corresponding to compressor.
- Resume condition: Check whether the IPM module is working.
- Reset method: Change the module board. Power on and start up again.

6.20.3 Possible causes

- There IPM module is damaged.

6.20.4 Procedure

- Check whether the IPM virtual welding and the PWM related transmission circuit of the MCU are connected to the welding. If so, change the replace the drive board.

6.21 L6E: Open circuit of W-phase upper tube

6.21.1 Description

- Open circuit of W-phase upper tube.
- After the fault, the compressor stops running, and if the fault disappears after one minute, the compressor starts again.

6.21.2 Trigger/resume condition

- Trigger condition: Open circuit of W-phase upper tube corresponding to compressor.
- Resume condition: Check whether the IPM module is working.
- Reset method: Change the module board. Power on and start up again.

6.21.3 Possible causes

- There IPM module is damaged.

6.21.4 Procedure

- Check whether the IPM virtual welding and the PWM related transmission circuit of the MCU are connected to the welding. If so, change the replace the drive board.

6.22 L6F: Open circuit of W-phase lower tube

6.22.1 Description

- Open circuit of W-phase lower tube.
- After the fault, the compressor stops running, and if the fault disappears after one minute, the compressor starts again.

6.22.2 Trigger/resume condition

- Trigger condition: Open circuit of W-phase lower tube corresponding to compressor.
- Resume condition: Check whether the IPM module is working.
- Reset method: Change the module board. Power on and start up again.

6.22.3 Possible causes

- There IPM module is damaged.

6.22.4 Procedure

- Check whether the IPM virtual welding and the PWM related transmission circuit of the MCU are connected to the welding. If so, change the replace the drive board.

7 Appendix

7.1 Temperature Sensor Resistance Characteristics

Outdoor ambient temperature sensor, suction temperature sensor, coil final outlet temperature sensor, air side heat exchanger pipe temperature sensor and refrigerant temperature sensor of EVI plate heat exchanger resistance characteristics.

Temperature (°C)	Resistance (kΩ)	Temperature (°C)	Resistance (kΩ)	Temperature (°C)	Resistance (kΩ)	Temperature (°C)	Resistance (kΩ)
-20	115.3	20	12.64	60	2.358	100	0.6297
-19	108.1	21	12.06	61	2.272	101	0.6115
-18	101.5	22	11.50	62	2.191	102	0.5939
-17	96.34	23	10.97	63	2.112	103	0.5768
-16	89.59	24	10.47	64	2.037	104	0.5604
-15	84.22	25	10.00	65	1.965	105	0.5445
-14	79.31	26	9.551	66	1.896	106	0.5291
-13	74.54	27	9.124	67	1.830	107	0.5143
-12	70.17	28	8.720	68	1.766	108	0.4999
-11	66.09	29	8.336	69	1.705	109	0.4860
-10	62.28	30	7.971	70	1.647	110	0.4726
-9	58.71	31	7.624	71	1.591	111	0.4596
-8	56.37	32	7.295	72	1.537	112	0.4470
-7	52.24	33	6.981	73	1.485	113	0.4348
-6	49.32	34	6.684	74	1.435	114	0.4230
-5	46.57	35	6.400	75	1.387	115	0.4116
-4	44.00	36	6.131	76	1.341	116	0.4006
-3	41.59	37	5.874	77	1.291	117	0.3899
-2	39.82	38	5.630	78	1.254	118	0.3796
-1	37.20	39	5.397	79	1.2133	119	0.3695
0	35.20	40	5.175	80	1.174	120	0.3598
1	33.33	41	4.964	81	1.136	121	0.3504
2	31.56	42	4.763	82	1.100	122	0.3413
3	29.91	43	4.571	83	1.064	123	0.3325
4	28.35	44	4.387	84	1.031	124	0.3239
5	26.88	45	4.213	85	0.9982	125	0.3156
6	25.50	46	4.046	86	0.9668	126	0.3075
7	24.19	47	3.887	87	0.9366	127	0.2997
8	22.57	48	3.735	88	0.9075	128	0.2922
9	21.81	49	3.590	89	0.8795	129	0.2848
10	20.72	50	3.451	90	0.8525	130	0.2777
11	19.69	51	3.318	91	0.8264	131	0.2708
12	18.72	52	3.192	92	0.8013	132	0.2641
13	17.80	53	3.071	93	0.7771	133	0.2576
14	16.93	54	2.959	94	0.7537	134	0.2513
15	16.12	55	2.844	95	0.7312	135	0.2451
16	15.34	56	2.738	96	0.7094	136	0.2392
17	14.62	57	2.637	97	0.6884	137	0.2334
18	13.92	58	2.540	98	0.6682	138	0.2278
19	13.26	59	2.447	99	0.6486	139	0.2223

Compressor discharge pipe temperature sensor resistance characteristics

Temperature (°C)	Resistance (kΩ)	Temperature (°C)	Resistance (kΩ)	Temperature (°C)	Resistance (kΩ)	Temperature (°C)	Resistance (kΩ)
-20	542.7	20	68.66	60	13.59	100	3.702
-19	511.9	21	65.62	61	13.11	101	3.595
-18	483.0	22	62.73	62	12.65	102	3.492
-17	455.9	23	59.98	63	12.21	103	3.392
-16	430.5	24	57.37	64	11.79	104	3.296
-15	406.7	25	54.89	65	11.38	105	3.203
-14	384.3	26	52.53	66	10.99	106	3.113
-13	363.3	27	50.28	67	10.61	107	3.025
-12	343.6	28	48.14	68	10.25	108	2.941
-11	325.1	29	46.11	69	9.902	109	2.860
-10	307.7	30	44.17	70	9.569	110	2.781
-9	291.3	31	42.33	71	9.248	111	2.704
-8	275.9	32	40.57	72	8.940	112	2.630
-7	261.4	33	38.89	73	8.643	113	2.559
-6	247.8	34	37.30	74	8.358	114	2.489
-5	234.9	35	35.78	75	8.084	115	2.422
-4	222.8	36	34.32	76	7.820	116	2.357
-3	211.4	37	32.94	77	7.566	117	2.294
-2	200.7	38	31.62	78	7.321	118	2.233
-1	190.5	39	30.36	79	7.086	119	2.174
0	180.9	40	29.15	80	6.859	120	2.117
1	171.9	41	28.00	81	6.641	121	2.061
2	163.3	42	26.90	82	6.430	122	2.007
3	155.2	43	25.86	83	6.228	123	1.955
4	147.6	44	24.85	84	6.033	124	1.905
5	140.4	45	23.89	85	5.844	125	1.856
6	133.5	46	22.89	86	5.663	126	1.808
7	127.1	47	22.10	87	5.488	127	1.762
8	121.0	48	21.26	88	5.320	128	1.717
9	115.2	49	20.46	89	5.157	129	1.674
10	109.8	50	19.69	90	5.000	130	1.632
11	104.6	51	18.96	91	4.849		
12	99.69	52	18.26	92	4.703		
13	95.05	53	17.58	93	4.562		
14	90.66	54	16.94	94	4.426		
15	86.49	55	16.32	95	4.294		
16	82.54	56	15.73	96	4.167		
17	78.79	57	15.16	97	4.045		
18	75.24	58	14.62	98	3.927		
19	71.86	59	14.09	99	3.812		

Water side antifreeze temperature sensor, leaving water temperature sensor, entering water temperature and total leaving water temperature sensor resistance characteristics

Temperature (°C)	Resistance (kΩ)	Temperature (°C)	Resistance (kΩ)	Temperature (°C)	Resistance (kΩ)	Temperature (°C)	Resistance (kΩ)
-20	470.8	20	61.2	60	12.2	100	3.3
-19	444.5	21	58.5	61	11.7	101	3.2
-18	419.9	22	55.9	62	11.3	102	3.1
-17	396.8	23	53.5	63	10.9	103	3.0
-16	375.1	24	51.2	64	10.5	104	2.9
-15	354.7	25	49.0	65	10.2	105	2.8
-14	335.5	26	46.9	66	9.8	106	2.8
-13	317.5	27	44.9	67	9.5	107	2.7
-12	300.5	28	43.0	68	9.2	108	2.6
-11	284.6	29	41.2	69	8.8	109	2.5
-10	269.6	30	39.4	70	8.5	110	2.5
-9	255.4	31	37.8	71	8.3	111	2.4
-8	242.1	32	36.2	72	8.0	112	2.3
-7	229.6	33	34.7	73	7.7	113	2.3
-6	217.8	34	33.3	74	7.5	114	2.2
-5	206.6	35	31.9	75	7.2	115	2.1
-4	196.1	36	30.7	76	7.0	116	2.1
-3	186.2	37	29.4	77	6.8	117	2.0
-2	176.8	38	28.2	78	6.5	118	2.0
-1	168.0	39	27.1	79	6.3	119	1.9
0	159.7	40	26.0	80	6.1	120	1.9
1	151.8	41	25.0	81	5.9	121	1.8
2	144.3	42	24.0	82	5.7	122	1.8
3	137.3	43	23.1	83	5.5	123	1.7
4	130.6	44	22.2	84	5.4	124	1.7
5	124.3	45	21.4	85	5.2	125	1.6
6	118.3	46	20.5	86	5.0	126	1.6
7	112.7	47	19.7	87	4.9	127	1.6
8	107.3	48	19.0	88	4.7	128	1.5
9	102.3	49	18.3	89	4.6	129	1.5
10	97.5	50	17.6	90	4.4	130	1.4
11	92.9	51	16.9	91	4.3		
12	88.6	52	16.3	92	4.2		
13	84.5	53	15.7	93	4.1		
14	80.6	54	15.1	94	3.9		
15	77.0	55	14.6	95	3.8		
16	73.5	56	14.1	96	3.7		
17	70.1	57	13.6	97	3.6		
18	67.0	58	13.1	98	3.5		
19	64.0	59	12.6	99	3.4		

7.2 Normal Operating Parameters of Refrigerant System

- If the outdoor ambient temperature is high, the system is being run in normal cooling mode with the following settings: temperature 5°C.
- If the outdoor ambient temperature is low, the system is being run in heating mode with the following settings: temperature 55°C.
- The system has been running normally for more than 30 minutes.

For SCV-750EB and SCV-1400EB

Outdoor unit in normal cooling mode operating parameters

Outdoor ambient temperature	°C	< 10	10 to 25	25 to 35	35 to 48
Average discharge temperature	°C	40-95	65-105	65-105	75-107
Average discharge superheat	°C	15-50	25-60	25-65	30-60
Discharge pressure	MPa	1.6-2.9	2.1-3.0	2.3-3.8	2.6-4.1
Average suction superheat	°C	2-20	2-25	2-25	3-25
Suction pressure	MPa	0.6-1.3	0.7-1.0	0.7-1.3	0.7-1.4
Average suction temperature	°C	1-30	3-30	3-35	5-40
T3	°C	5-40	15-40	30-48	35-54
Tz/7	°C	/	/	/	/
Taf	°C	5-25	5-25	5-25	5-25
T6A/B	°C	/	5-30	8-30	10-40
Twi	°C	10-25	10-25	10-25	10-25
Two	°C	5-20	5-20	5-20	5-20
Tw	°C	5-20	5-20	5-20	5-20
DC fan motor current	A	0.2-4 (75KW) 0.2-6(140KW)	1-4 (75KW) 1-6 (140KW)	1.5-4 (75KW) 1.5-6 (140KW)	2-4 (75KW) 2-6 (140KW)
DC inverter compressor current	A	15-45	15-47	20-53	20-53

Outdoor unit in heating mode operating parameters

Outdoor ambient temperature	°C	< -10	-10 to 0	0 to 7	7 to 20	> 20
Average discharge temperature	°C	60-105	60-105	60-105	65-105	65-105
Average discharge superheat	°C	35-55	35-63	30-60	20-55	20-55
Discharge pressure	MPa	1.6-3.5	1.8-3.7	2.0-3.9	2.0-4.0	2.5-4.0
Average suction superheat	°C	-2-10	-5-15	-2-10	0-8	0-10
Suction pressure	MPa	0.2-0.5	0.25-0.65	0.3-0.9	0.6-1.2	0.7-1.4
Average suction temperature	°C	-25 to -5	-22 to 2	-12 to 7	0 to 15	5 to 25
T3	°C	-25 to -11	-22 to 0	-12 to 6	0 to 19	5 to 40
Tz/7	°C	20 to 55	20 to 55	20 to 55	20 to 55	20 to 55
Taf	°C	20-55	20-55	20-55	20-55	20-55
T6A/B	°C	-10-35	0-45	0-40	8-45	/
Twi	°C	20-50	20-50	20-50	20-50	20-50
Two	°C	25-55	25-55	25-55	25-55	25-55
Tw	°C	25-55	25-55	25-55	25-55	25-55
DC fan motor current	A	1-4 (75KW) 1-6 (140KW)	1-4 (75KW) 1-6 (140KW)	1-4 (75KW) 1-6 (140KW)	1-3.5 (75KW) 1-5 (140KW)	1-3.5 (75KW) 1-5 (140KW)
DC inverter compressor current	A	10-45	10-45	20-53	20-53	15-45

Outdoor unit in normal cooling mode operating parameters

Outdoor ambient temperature	°C	< 10	10 to 25	25 to 35	35 to 48
Average discharge temperature	°C	60-90	65-95	70-99	75-105
Average discharge superheat	°C	15-30	28-40	29-42	30-46
Discharge pressure	MPa	1.8-2.9	1.9-3.2	2.0-3.8	2.6-3.9
Average suction superheat	°C	3-7	2-6	1-5	0-5
Suction pressure	MPa	0.6-0.9	0.7-1.0	0.8-1.2	1.0-1.3
Average suction temperature	°C	7-18	7-20	8-22	10-25
T3	°C	10-25	15-35	30-48	48-54
Tz	°C	20-30	20-35	28-46	44-52
Taf	°C	5-25	5-25	5-25	5-25
T6A/B	°C	/	0-20	3-30	5-40
Twi	°C	10-25	10-25	10-25	10-25
Two	°C	5-20	5-20	5-20	5-20
Tw	°C	5-20	5-20	5-20	5-20
DC fan motor current	A	0.2-4	1-4	1.5-4	2-4
DC inverter compressor current	A	15-45	15-48	20-56	20-56

Outdoor unit in heating mode operating parameters

Outdoor ambient temperature	°C	< -10	-10 to 0	0 to 7	7 to 20	> 20
Average discharge temperature	°C	50-104	55-103	60-103	65-102	70-100
Average discharge superheat	°C	35-55	35-55	32-50	34-50	35-50
Discharge pressure	MPa	1.8-2.9	1.9-2.9	1.9-3.4	2.2-3.6	2.4-3.9
Average suction superheat	°C	-2-0	-2-2	-1-4	0-6	1-8
Suction pressure	MPa	0.2-0.5	0.3-0.7	0.4-0.9	0.6-1.2	0.8-1.4
Average suction temperature	°C	-25 to -11	-16 to 2	-10 to 5	0 to 15	5 to 18
T3	°C	-25 to -11	-16 to 0	-10 to 2	1 to 15	5 to 20
Tz	°C	-19 to -4	-14 to 0	-5 to 7	1 to 15	2 to 20
Taf	°C	20-45	20-50	20-54	20-54	20-54
T6A/B	°C	-2-20	0-25	3-35	8-40	/
Twi	°C	20-40	20-45	20-50	20-50	20-50
Two	°C	25-45	25-50	25-54	25-54	25-54
Tw	°C	25-45	25-50	25-54	25-54	25-54
DC fan motor current	A	1-4	1-4	1-4	1-3	1-3
DC inverter compressor current	A	10-45	10-45	20-54	20-54	15-45

NOTE CONCERNING PROTECTION OF ENVIRONMENT



This product must not be disposed of via normal household waste after its service life, but must be taken to a collection station for the recycling of electrical and electronic devices. The symbol on the product, the operating instructions or the packaging indicate such disposal procedures. The materials are recyclable in accordance with their respective symbols. By means of re-use, material recycling or any other form of recycling old appliances you are making an important contribution to the protection of our environment. Please ask your local council where your nearest disposal station is located.

INFORMATION CONCERNING USED REFRIGERANT MEDIUM

This unit is containing fluorinated gases included in the Kyoto protocol. The maintenance and the liquidation must be carried out by qualified personnel.

Type of refrigerant: R32

The quantity of the refrigerant: please see the unit label.

The value GWP: 675 (1 kg R32 = 0,675 t CO₂ eq)

GWP = Global Warming Potential



Appliance filled with flammable gas R32.

In case of quality problem or other please contact your local supplier or authorized service center.

Emergency number: 112

PRODUCER

SINCLAIR CORPORATION Ltd.

1-4 Argyll St.

London W1F 7LD

Great Britain

www.sinclair-world.com

This product was manufactured in China (Made in China).

REPRESENTATIVE

SINCLAIR Global Group s.r.o.

Purkynova 45

612 00 Brno

Czech Republic

TECHNICAL SUPPORT

SINCLAIR Global Group s.r.o.

Purkynova 45

612 00 Brno

Czech Republic

Tel.: +420 800 100 285

Fax: +420 541 590 124

www.sinclair-solutions.com

info@sinclair-solutions.com

