

SERVICE MANUAL

NEW MULTI SYSTEM SERIES

**MS-E14AIN, MS-E18AIN, MS-E21AIN,
MS-24AIN, MS-E28AIN**



Table of Contents

Part I : Technical Information	1
1. Summary	1
2. Specifications	2
3. Outline Dimension Diagram	12
4. Refrigerant System Diagram	14
5. Electrical Part	15
5.1 Wiring Diagram.....	15
5.2 PCB Printed Diagram.....	20
6. Function and Control	22
Part II : Installation and Maintenance	25
7. Notes for Installation and Maintenance	25
8. Installation Manual	27
8.1 Electrical Connections.....	28
8.2 Installing the Outdoor Unit.....	31
8.3 Installation Dimension Diagram.....	32
8.4 Check after Installation.....	33
9. Maintenance	34
9.1 Precautions before Performing Inspection or Repair.....	34
9.2 Flashing LED of Indoor/Outdoor Unit and Primary Judgement.....	35
9.3 Malfunction Checking and Elimination.....	36
9.4 Maintenance Method for Normal Malfunction.....	49
10. Exploded View and Parts List	51
11. Removal Procedure	71
Appendix:	90
Appendix 1: Reference Sheet of Celsius and Fahrenheit.....	90
Appendix 2: Configuration of Connection Pipe.....	90
Appendix 3: Pipe Expanding Method.....	91
Appendix 4: List of Resistance for Temperature Sensor.....	92

2. Specifications

Model			MS-E14AIN	
Power supply	Rated Voltage	V~	220-240	
	Rated Frequency	Hz	50	
	Phases		1	
Cooling capacity(max~min)		W	4100(2052~4396)	
Heating capacity(max~min)		W	4400(2491~5422)	
Cooling Power Input(max~min)		W	1200	
Heating Power Input(max~min)		W	1180	
Cooling Current Input		A	5.32	
Heating Current Input		A	5.10	
Rated Power Input		W	1780	
Rated Current		A	7.90	
SEER		W/W	6.10	
SCOP		W/W	4.00	
Outdoor Unit	Compressor Trademark		ZHUHAI LANDA COMPRESSOR CO.,LTD	
	Compressor Model		QXA-B141zF030A	
	Compressor Refrigerant Oil Type		RB68EP	
	Compressor Type		Inverter Rotary	
	L.R.A		A	25
	Compressor Rated Load Amp (RLA)		A	7.2
	Compressor Power Input		W	1440
	Compressor Thermal Protector			"1NT11L-6233 KSD115°CHPC115/95U1"
	Throttling Method			Electron expansion valve
	Cooling Operation Ambient Temperature Range		°C	-15~43
	Heating Operation Ambient Temperature Range		°C	-20~24
	Condenser Material			Aluminum Fin-copper Tube
	Condenser Pipe Diameter		mm	F9.52
	Rows-Fin Gap(mm)		mm	2-1.4
	Coil length (l) X height (H) X coil width (L)		mm	800X44X559
	Fan Motor Speed (rpm) (H/M/L)		rpm	900
	Output of Fan Motor		W	30
	Fan Motor RLA		A	/
	Fan Motor Capacitor		μF	/
	Air Flow Volume of Outdoor Unit		m ³ /h	2600
	Fan Type-Piece			Axial-flow
	Fan Diameter		mm	F438-1 16
	Defrosting Method			Automatic Defrosting
	Climate Type			T1
	Isolation			I
	Moisture Protection			IP24
	Permissible Excessive Operating Pressure for the Discharge Side		MPa	4.3
	Permissible Excessive Operating Pressure for the Suction Side		MPa	2.5
	Dimension (W/H/D)		mm	903X596X378
	Dimension of Package (L/W/H)		mm	945X417X630
Dimension of Package(L/W/H)		mm	948X420X645	
Net Weight		kg	43	
Gross Weight		kg	46	
Refrigerant Charge			R410A	
Refrigerant Charge		kg	1.40	

Outdoor Unit	Cross-sectional Area of Power Cable Conductor	mm ²	/
	Recommended Power Cable(Core)	N	3
	Connection Pipe Connection Method	-	Flare Connection
	Not Additional Gas Connection Pipe Length	m	10
	Connection Pipe Gas Additional Charge	g/m	20
	Outer Diameter of Liquid Pipe(GREE Allocation) (Metric)	mm	6
	Outer Diameter of Gas Pipe(GREE Allocation) (Metric)	mm	9.52
	Outer Diameter of Liquid Pipe(GREE Allocation) (Metric)	mm	6
	Outer Diameter of Gas Pipe(GREE Allocation) (Metric)	mm	9.52
	Connection Pipe Max. Height Distance(indoor and indoor)	m	5
	Max. equivalent connection pipe length(outdoor to last indoor)	m	10
Connection Pipe Max. Length Distance(total length)	m	20	

The above data is subject to change without notice; please refer to the nameplate of the unit.

Model			MS-E18AIN	
Power supply	Rated Voltage	V~	220-240	
	Rated Frequency	Hz	50	
	Phases		1	
Cooling capacity(max~min)		W	5200(2140~5800)	
Heating capacity(max~min)		W	5400(2579~5920)	
Cooling Power Input(max~min)		W	1450	
Heating Power Input(max~min)		W	1450	
Cooling Current Input		A	6.88	
Heating Current Input		A	6.43	
Rated Power Input		W	1780	
Rated Current		A	7.90	
SEER		W/W	6.1	
SCOP		W/W	4.0	
Outdoor Unit	Compressor Trademark		ZHUHAI LANDA COMPRESSOR CO.,LTD	
	Compressor Model		QXA-B141zF030A	
	Compressor Refrigerant Oil Type		RB68EP	
	Compressor Type		Inverter Rotary	
	L.R.A		A	25
	Compressor Rated Load Amp (RLA)		A	7.2
	Compressor Power Input		W	1440
	Compressor Thermal Protector			"1NT11L-6233 KSD115°CHPC115/95U1"
	Throttling Method			Electron expansion valve
	Cooling Operation Ambient Temperature Range		°C	-15~43
	Heating Operation Ambient Temperature Range		°C	-20~24
	Condenser Material			Aluminum Fin-copper Tube
	Condenser Pipe Diameter		mm	F7
	Rows-Fin Gap(mm)		mm	2-1.4
	Coil length (l) X height (H) X coil width (L)		mm	851X38.1X660
	Fan Motor Speed (rpm) (H/M/L)		rpm	800
	Output of Fan Motor		W	60
	Fan Motor RLA		A	/
	Fan Motor Capacitor		μF	/
	Air Flow Volume of Outdoor Unit		m ³ /h	3200
	Fan Type-Piece			Axial-flow
	Fan Diameter		mm	F520-154
	Defrosting Method			Automatic Defrosting
	Climate Type			T1
	Isolation			I
	Moisture Protection			IP24
	Permissible Excessive Operating Pressure for the Discharge Side		MPa	4.3
	Permissible Excessive Operating Pressure for the Suction Side		MPa	2.5
	Dimension (WXHXD)		mm	963X700X396
	Dimension of Package (LXWXH)		mm	1026X455X735
	Dimension of Package(LXWXH)		mm	1029X458X750
	Net Weight		kg	51
Gross Weight		kg	55	
Refrigerant Charge			R410A	
Refrigerant Charge		kg	1.60	

Outdoor Unit	Cross-sectional Area of Power Cable Conductor	mm ²	/
	Recommended Power Cable(Core)	N	3
	Connection Pipe Connection Method	-	Flare Connection
	Not Additional Gas Connection Pipe Length	m	10
	Connection Pipe Gas Additional Charge	g/m	20
	Outer Diameter of Liquid Pipe(GREE Allocation) (Metric)	mm	6
	Outer Diameter of Gas Pipe(GREE Allocation) (Metric)	mm	9.52
	Outer Diameter of Liquid Pipe(GREE Allocation) (Metric)	mm	6
	Outer Diameter of Gas Pipe(GREE Allocation) (Metric)	mm	9.52
	Connection Pipe Max. Height Distance(indoor and indoor)	m	5
	Max. equivalent connection pipe length(outdoor to last indoor)	m	10
	Connection Pipe Max. Length Distance(total length)	m	20

The above data is subject to change without notice; please refer to the nameplate of the unit.

Model			MS-E21AIN	
Power supply	Rated Voltage	V~	220-240	
	Rated Frequency	Hz	50	
	Phases		1	
Cooling capacity(max~min)		W	6100(2198~7327)	
Heating capacity(max~min)		W	6500(3605~8499)	
Cooling Power Input(max~min)		W	1910	
Heating Power Input(max~min)		W	1730	
Cooling Current Input		A	8.47	
Heating Current Input		A	7.68	
Rated Power Input		W	2870	
Rated Current		A	12.73	
SEER		W/W	6.1	
SCOP		W/W	4.0	
Outdoor Unit	Compressor Trademark		ZHUHAI LANDA COMPRESSOR CO.,LTD	
	Compressor Model		QXAS-D23zX090B	
	Compressor Refrigerant Oil Type		RB68EP	
	Compressor Type		Inverter Rotary	
	L.R.A		A	25
	Compressor Rated Load Amp (RLA)		A	11.5
	Compressor Power Input		W	2550
	Compressor Thermal Protector			"1NT11L-6233KSD115°C HPC115/95U1"
	Throttling Method			Electron expansion valve
	Cooling Operation Ambient Temperature Range		°C	-15~43
	Heating Operation Ambient Temperature Range		°C	-20~24
	Condenser Material			Aluminum Fin-copper Tube
	Condenser Pipe Diameter		mm	F9.52
	Rows-Fin Gap(mm)		mm	2-1.4
	Coil length (l) X height (H) X coil width (L)		mm	851X38.1X660
	Fan Motor Speed (rpm) (H/M/L)		rpm	800
	Output of Fan Motor		W	60
	Fan Motor RLA		A	/
	Fan Motor Capacitor		μF	/
	Air Flow Volume of Outdoor Unit		m ³ /h	3200
	Fan Type-Piece			Axial-flow
	Fan Diameter		mm	F520-154
	Defrosting Method			Automatic Defrosting
	Climate Type			T1
	Isolation			I
	Moisture Protection			IP24
	Permissible Excessive Operating Pressure for the Discharge Side		MPa	4.3
	Permissible Excessive Operating Pressure for the Suction Side		MPa	2.5
	Dimension (WXHXD)		mm	963X700X396
	Dimension of Package (LXWXH)		mm	1026X455X735
Dimension of Package(LXWXH)		mm	1029X458X750	
Net Weight		kg	62	
Gross Weight		kg	65.5	
Refrigerant Charge			R410A	
Refrigerant Charge		kg	2.2	

Outdoor Unit	Cross-sectional Area of Power Cable Conductor	mm ²	/
	Recommended Power Cable(Core)	N	3
	Connection Pipe Connection Method	-	Flare Connection
	Not Additional Gas Connection Pipe Length	m	30
	Connection Pipe Gas Additional Charge	g/m	20
	Outer Diameter of Liquid Pipe(GREE Allocation) (Metric)	mm	6
	Outer Diameter of Gas Pipe(GREE Allocation) (Metric)	mm	9.52
	Outer Diameter of Liquid Pipe(GREE Allocation) (Metric)	mm	6
	Outer Diameter of Gas Pipe(GREE Allocation) (Metric)	mm	9.52
	Outer Diameter of Liquid Pipe(GREE Allocation) (Metric)	mm	6
	Outer Diameter of Gas Pipe(GREE Allocation) (Metric)	mm	9.52
	Connection Pipe Max. Height Distance(indoor and indoor)	m	10
	Max. equivalent connection pipe length(outdoor to last indoor)	m	20
Connection Pipe Max. Length Distance(total length)	m	60	

The above data is subject to change without notice; please refer to the nameplate of the unit.

Model			MS-E24AIN	
Power supply	Rated Voltage	V~	220-240	
	Rated Frequency	Hz	50	
	Phases		1	
Cooling capacity(max~min)		W	7100(2286~8499)	
Heating capacity(max~min)		W	8500(3664~8792)	
Cooling Power Input(max~min)		W	2180	
Heating Power Input(max~min)		W	2280	
Cooling Current Input		A	9.67	
Heating Current Input		A	10.12	
Rated Power Input		W	2870	
Rated Current		A	12.73	
SEER		W/W	6.1	
SCOP		W/W	4.0	
Outdoor Unit	Compressor Trademark		ZHUHAI LANDA COMPRESSOR CO.,LTD	
	Compressor Model		QXAS-D23zX090B	
	Compressor Refrigerant Oil Type		RB68EP	
	Compressor Type		Inverter Rotary	
	L.R.A		A	25
	Compressor Rated Load Amp (RLA)		A	11.5
	Compressor Power Input		W	2550
	Compressor Thermal Protector			"1NT11L-6233KSD115°C HPC115/95U1"
	Throttling Method			Electron expansion valve
	Cooling Operation Ambient Temperature Range		°C	-15~43
	Heating Operation Ambient Temperature Range		°C	-20~24
	Condenser Material			Aluminum Fin-copper Tube
	Condenser Pipe Diameter		mm	F7
	Rows-Fin Gap(mm)		mm	2-1.4
	Coil length (l) X height (H) X coil width (L)		mm	982.2X38.1X748
	Fan Motor Speed (rpm) (H/M/L)		rpm	800
	Output of Fan Motor		W	90
	Fan Motor RLA		A	/
	Fan Motor Capacitor		µF	/
	Air Flow Volume of Outdoor Unit		m ³ /h	3200
	Fan Type-Piece			Axial-flow
	Fan Diameter		mm	F520-120
	Defrosting Method			Automatic Defrosting
	Climate Type			T1
	Isolation			I
	Moisture Protection			IP24
	Permissible Excessive Operating Pressure for the Discharge Side		MPa	4.3
	Permissible Excessive Operating Pressure for the Suction Side		MPa	2.5
	Dimension (WXHxD)		mm	1001X790X427
	Dimension of Package (LXWXH)		mm	1080X485X840
Dimension of Package(LXWXH)		mm	1083X488X855	
Net Weight		kg	68	
Gross Weight		kg	73	
Refrigerant Charge			R410A	
Refrigerant Charge		kg	2.2	

Outdoor Unit	Cross-sectional Area of Power Cable Conductor	mm ²	/
	Recommended Power Cable(Core)	N	3
	Connection Pipe Connection Method	-	Flare Connection
	Not Additional Gas Connection Pipe Length	m	30
	Connection Pipe Gas Additional Charge	g/m	20
	Outer Diameter of Liquid Pipe(GREE Allocation) (Metric)	mm	6
	Outer Diameter of Gas Pipe(GREE Allocation) (Metric)	mm	9.52
	Outer Diameter of Liquid Pipe(GREE Allocation) (Metric)	mm	6
	Outer Diameter of Gas Pipe(GREE Allocation) (Metric)	mm	9.52
	Outer Diameter of Liquid Pipe(GREE Allocation) (Metric)	mm	6
	Outer Diameter of Gas Pipe(GREE Allocation) (Metric)	mm	9.52
	Connection Pipe Max. Height Distance(indoor and indoor)	m	10
	Max. equivalent connection pipe length(outdoor to last indoor)	m	20
	Connection Pipe Max. Length Distance(total length)	m	60

The above data is subject to change without notice. Please refer to the nameplate of the unit.

Model			MS-E28AIN	
Power supply	Rated Voltage	V~	220-240	
	Rated Frequency	Hz	50	
	Phases		1	
Cooling capacity(max~min)		W	8000(2286~10258)	
Heating capacity(max~min)		W	9300(3664~10258)	
Cooling Power Input(max~min)		W	2540	
Heating Power Input(max~min)		W	2490	
Cooling Current Input		A	15.71	
Heating Current Input		A	11.05	
Rated Power Input		W	3580	
Rated Current		A	15.88	
SEER		W/W	6.1	
SCOP		W/W	4.0	
Outdoor Unit	Compressor Trademark		ZHUHAI LANDA COMPRESSOR CO.,LTD	
	Compressor Model		QXAS-D23zX090B	
	Compressor Refrigerant Oil Type		RB68EP	
	Compressor Type		Inverter Rotary	
	L.R.A		A	25
	Compressor Rated Load Amp (RLA)		A	11.5
	Compressor Power Input		W	2550
	Compressor Thermal Protector			"1NT11L-6233KSD115°C HPC115/95U1"
	Throttling Method			Electron expansion valve
	Cooling Operation Ambient Temperature Range		°C	-15~43
	Heating Operation Ambient Temperature Range		°C	-20~24
	Condenser Material			Aluminum Fin-copper Tube
	Condenser Pipe Diameter		mm	F7
	Rows-Fin Gap(mm)		mm	2-1.4
	Coil length (l) X height (H) X coil width (L)		mm	982.2X38.1X748
	Fan Motor Speed (rpm) (H/M/L)		rpm	800
	Output of Fan Motor		W	90
	Fan Motor RLA		A	/
	Fan Motor Capacitor		μF	/
	Air Flow Volume of Outdoor Unit		m ³ /h	4000
	Fan Type-Piece			Axial-flow
	Fan Diameter		mm	F520-120
	Defrosting Method			Automatic Defrosting
	Climate Type			T1
	Isolation			I
	Moisture Protection			IP24
	Permissible Excessive Operating Pressure for the Discharge Side		MPa	4.3
	Permissible Excessive Operating Pressure for the Suction Side		MPa	2.5
	Dimension (WXHXD)		mm	1001X790X427
	Dimension of Package (LXWXH)		mm	1080X485X840
Dimension of Package(LXWXH)		mm	1083X488X855	
Net Weight		kg	69	
Gross Weight		kg	74	
Refrigerant Charge			R410A	
Refrigerant Charge		kg	2.60	

Outdoor Unit	Cross-sectional Area of Power Cable Conductor	mm ²	/
	Recommended Power Cable(Core)	N	3
	Connection Pipe Connection Method	-	Flare Connection
	Not Additional Gas Connection Pipe Length	m	40
	Connection Pipe Gas Additional Charge	g/m	20
	Outer Diameter of Liquid Pipe(GREE Allocation) (Metric)	mm	6
	Outer Diameter of Gas Pipe(GREE Allocation) (Metric)	mm	9.52
	Outer Diameter of Liquid Pipe(GREE Allocation) (Metric)	mm	6
	Outer Diameter of Gas Pipe(GREE Allocation) (Metric)	mm	9.52
	Outer Diameter of Liquid Pipe(GREE Allocation) (Metric)	mm	6
	Outer Diameter of Gas Pipe(GREE Allocation) (Metric)	mm	9.52
	Connection Pipe Max. Height Distance(indoor and indoor)	m	10
	Max. equivalent connection pipe length(outdoor to last indoor)	m	20
	Connection Pipe Max. Length Distance(total length)	m	70

The above data is subject to change without notice. Please refer to the nameplate of the unit.

3. Outline Dimension Diagram

(1)Model:MS-E14AIN

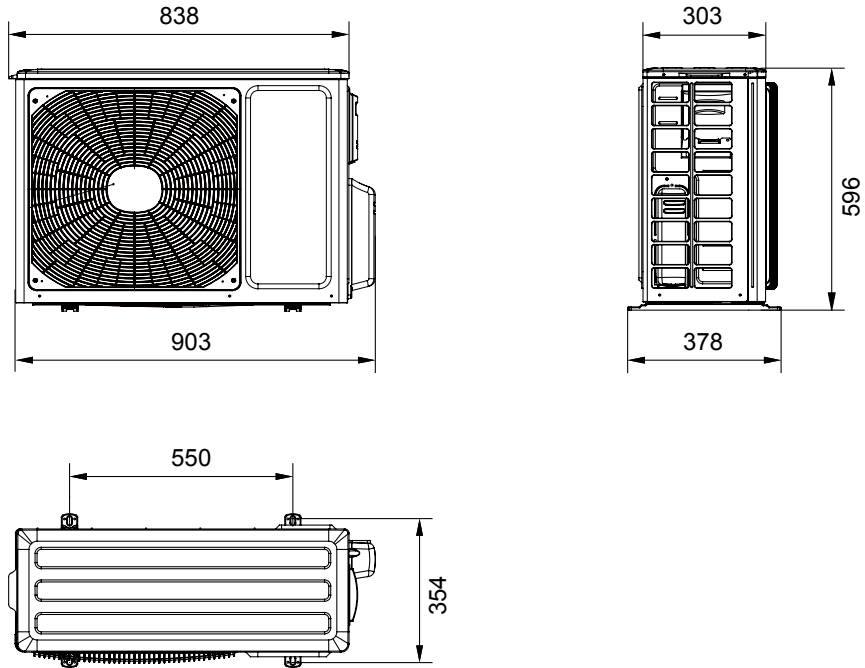

Unit:mm

(2)Models:MS-E18AIN, MS-E21AIN

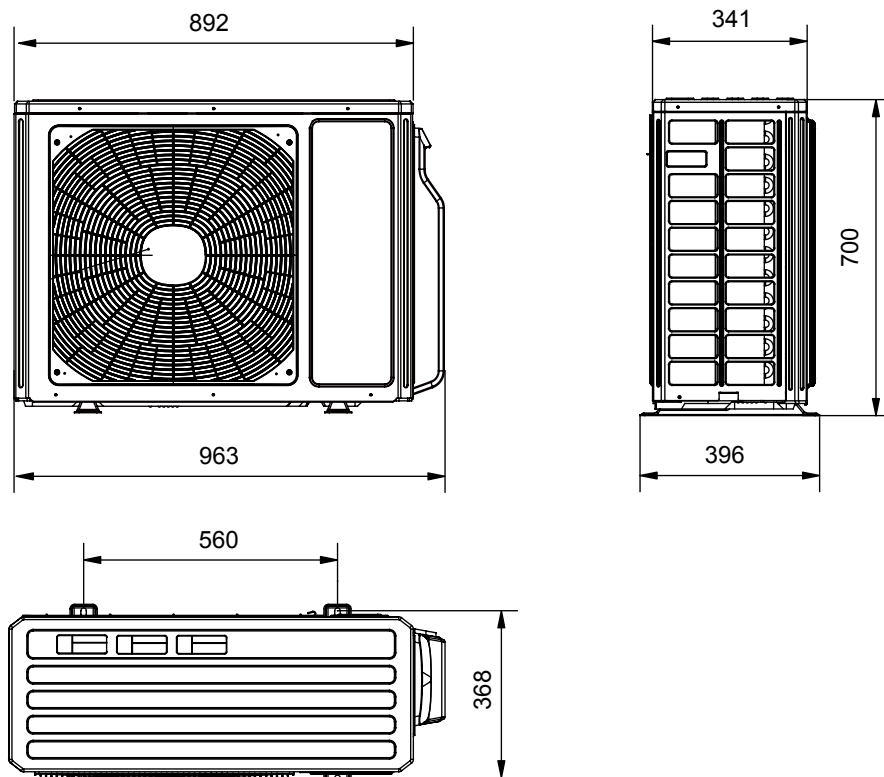

Unit:mm

(3)Models:MS-E24AIN, MS-E28AIN

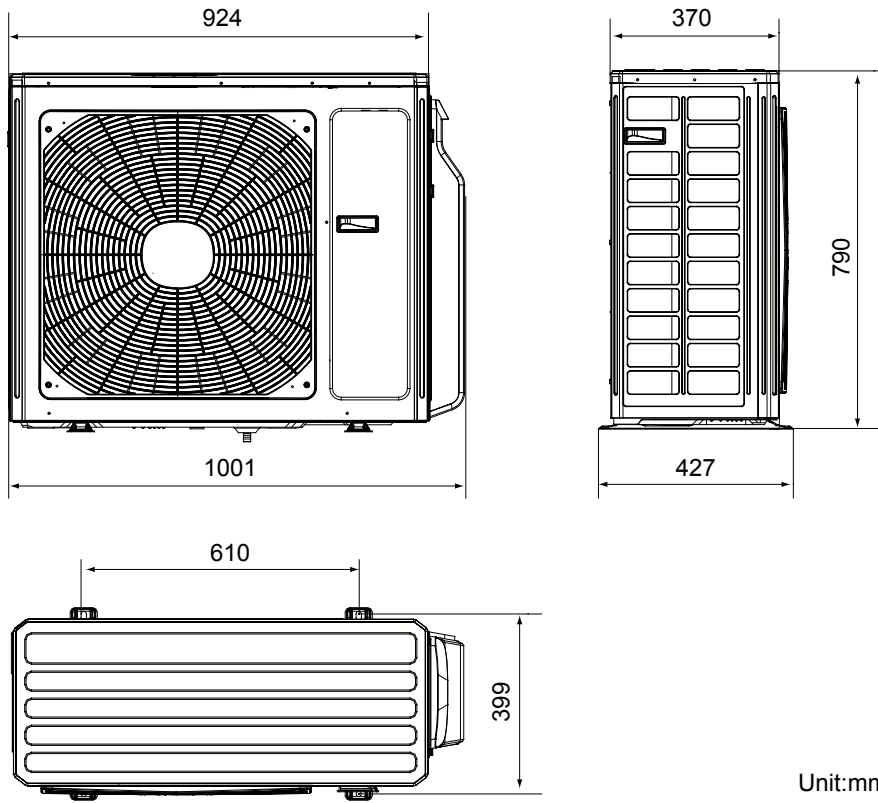

Unit:mm

4. Refrigerant System Diagram

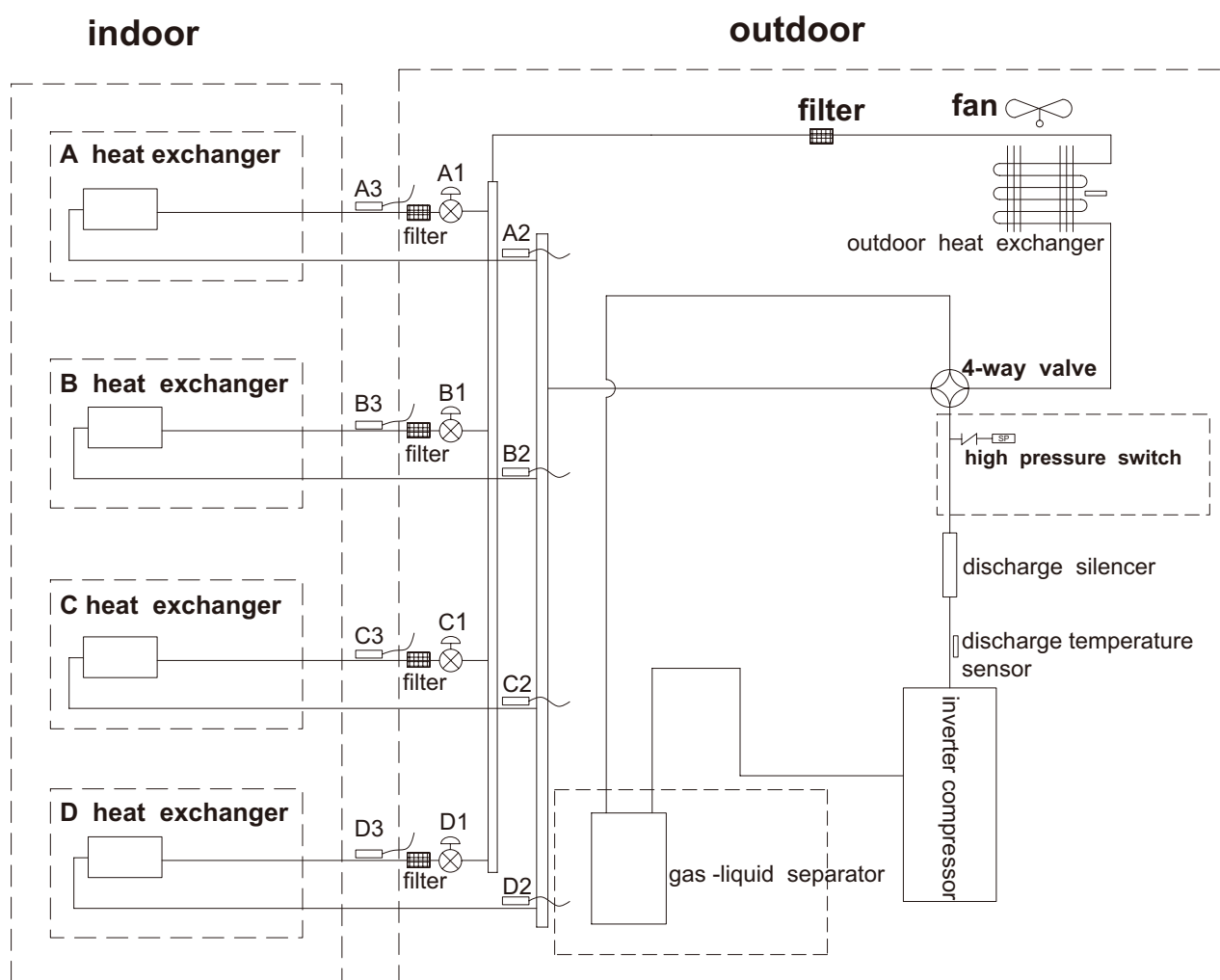

A1:A-unit electronic expansion valve B1:B-unit electronic expansion valve
C1:C-unit electronic expansion valve D1:D-unit electronic expansion valve
A2:A-unit gas pipe temperature sensor B2:B-unit gas pipe temperature sensor
C2:C-unit gas pipe temperature sensor D2:D-unit gas pipe temperature sensor
A3:A-unit liquid pipe temperature sensor B3:B-unit liquid pipe temperature sensor
C3:C-unit liquid pipe temperature sensor D3:D-unit liquid pipe temperature sensor

5. Electrical Part

5.1 Wiring Diagram

• Instruction

Symbol	Symbol Color	Symbol	Symbol Color	Symbol	Name
WH	White	GN	GREEN	COMP	Compressor
YE	Yellow	BN	Brown		Grounding wire
RD	Red	BU	Blue		
YEGN	Yellow/Green	BK	Black		
VT	Violet	OG	Orange		

• Outdoor Unit

Models:MS-E14AIN, MS-E18AIN

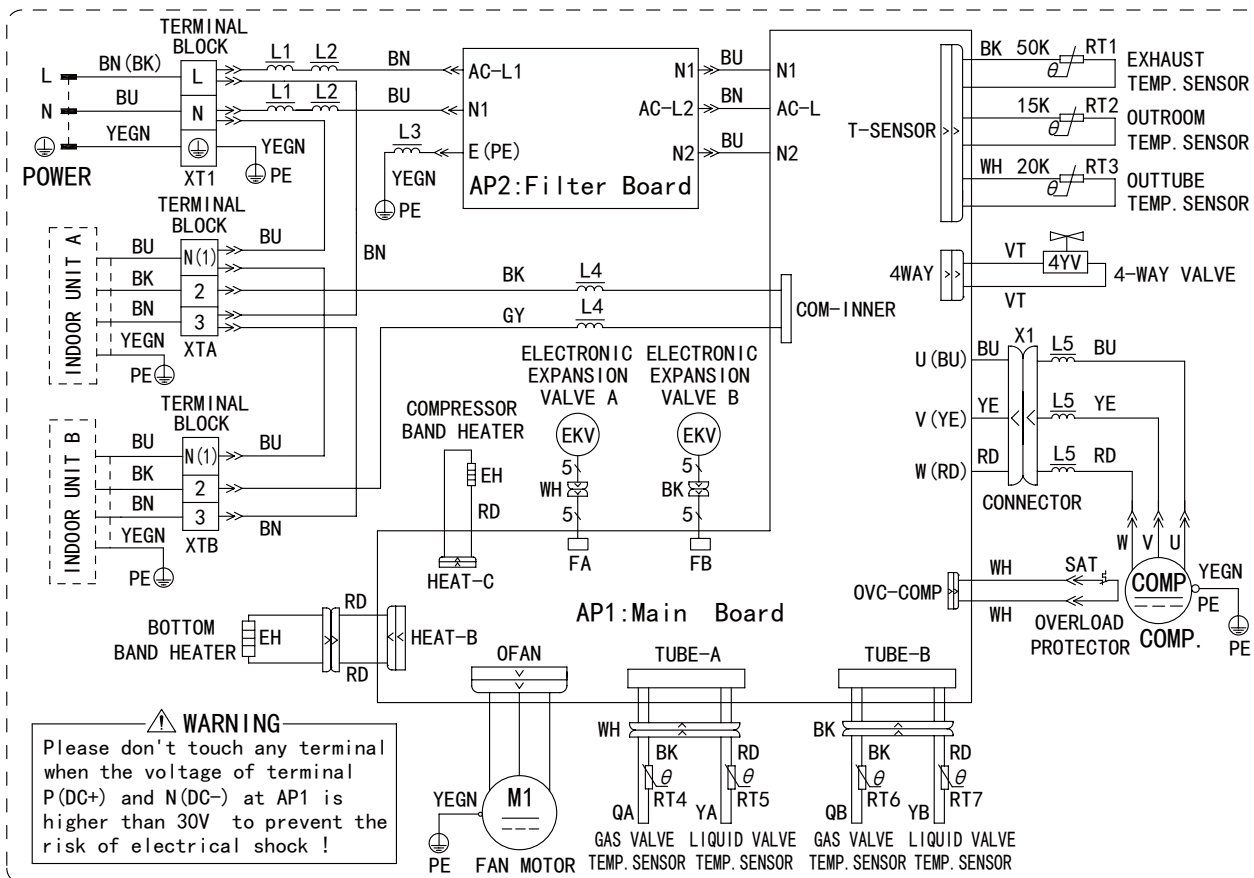

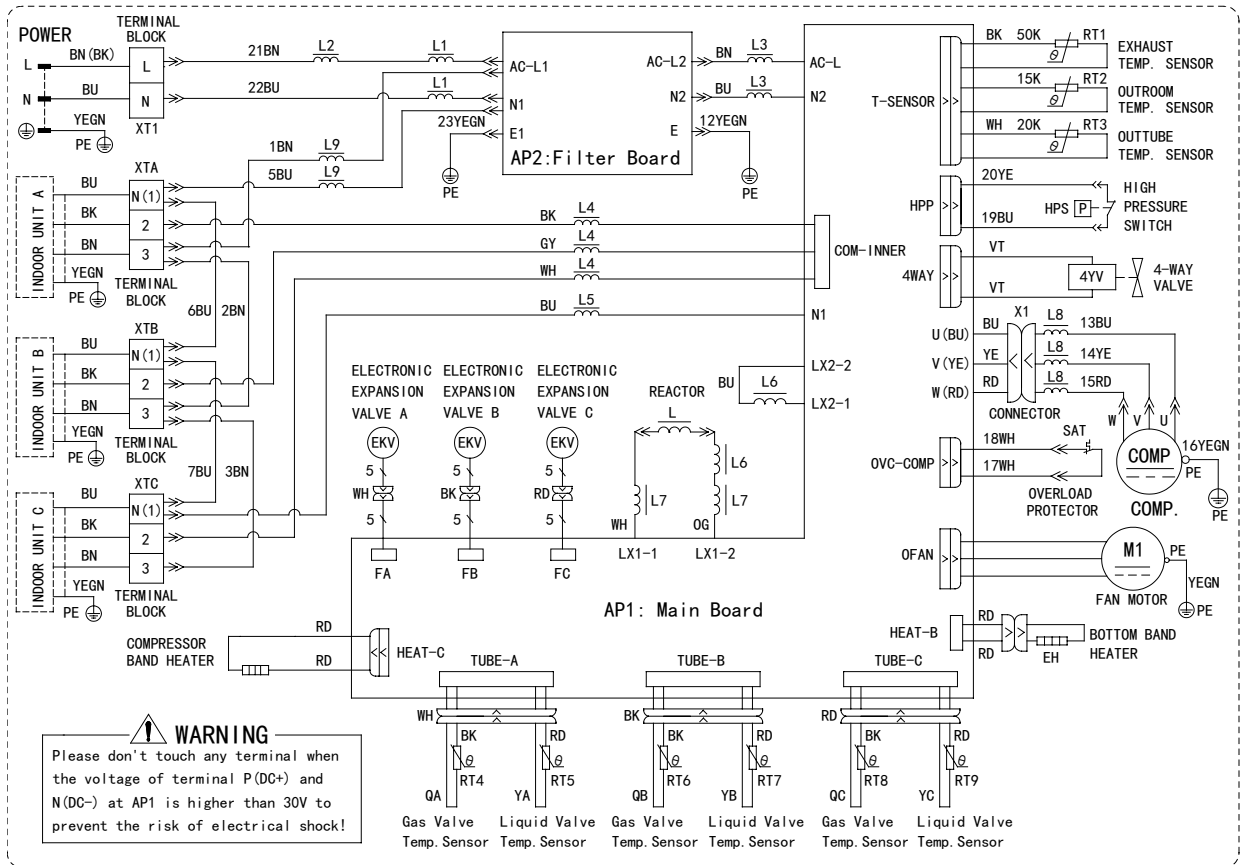

• Top view

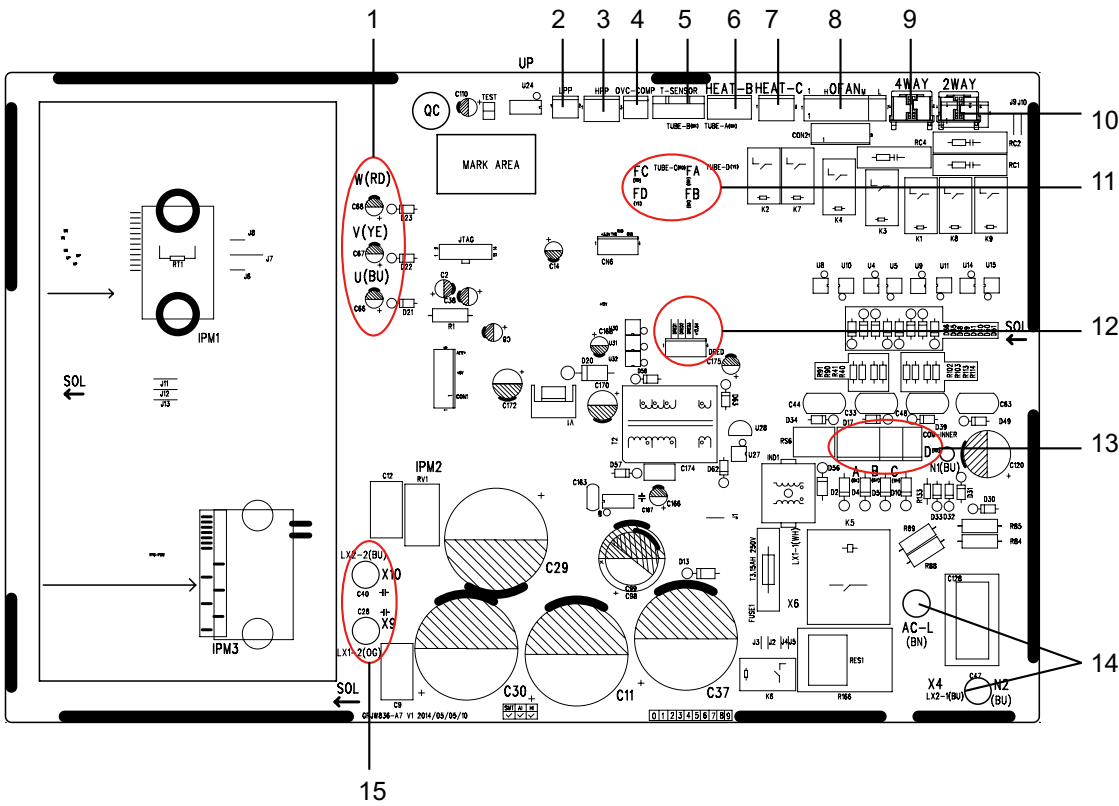

1	Terminal of compressor
2	Low-pressure protection terminal
3	High-pressure protection terminal
4	Overload protection terminal of compressor
5	Terminal of temperature sensor
6	Electric heating terminal of chassis
7	Electric heating terminal of compressor
8	Terminal of outdoor fan
9	4-way valve terminal
10	2-way valve terminal
11	气阀、液阀接口电路
12	DRED 网线接口
13	Terminal of neutral/live wire for communication
14	Terminal of neutral/live wire
15	PFC 电感线接口

• Bottom view

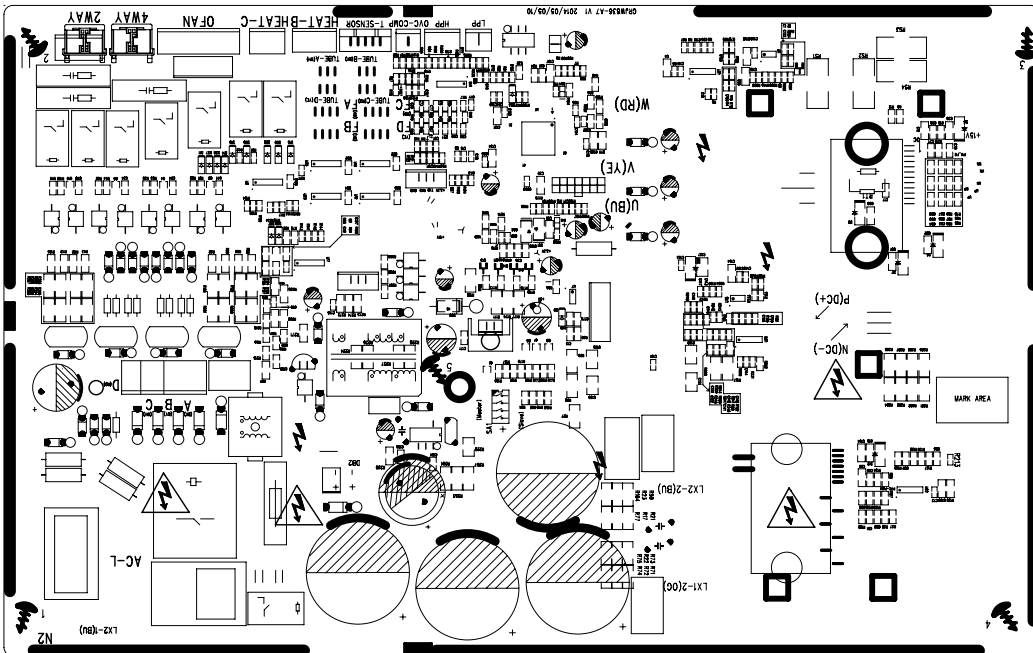

6. Function and Control

1 Basic functions of the system

1.1 Cooling Mode

1.1.1 Cooling conditions and process:

If the compressor is in stop status and start the unit for cooling operation, when one of the indoor units reaches the cooling operation condition, the unit start cooling operation; in this case, the electronic expansion valve, the outdoor fan and the compressor start operation.

1.1.2 Stop in cooling operation

1.1.2.1 Compressor stops

The compressor stops immediately, the outdoor fan stops after 1min.

1.1.2.2 Some of the indoor units reach the stop condition (the compressor does not stop)

The compressor operates immediately according to the required frequency. For the indoor unit with no requirement, the corresponding electronic expansion valve is closed to OP.

1.1.3 Cooling mode transfers to heating mode

When the unit transfers to heating mode, the 4-way valve is energized after the compressor stops for 2min. The other disposals are the same as stopping in cooling mode.

1.1.4 4-way valve: in this mode, the 4-way valve is closed.

1.1.5 Outdoor fan control in cooling mode

The outdoor fan starts before 5s of the starting of compressor. The outdoor fan will run in high speed for 3min after starting and then it will run in set speed. The fan shall run at every speed for at least 80s. (When the quantity of running indoor unit is changed, the unit will enter the control described in 1.3.5.1 and 1.3.5.2);

When the compressor stops, the outdoor fan runs at present speed and stops after 1min.

1.2 Dry Mode

1.2.1 The dry conditions and process are the same as those in cooling mode;

1.2.2 The status of 4-way valve: closed;

1.2.3 The temperature setting range: 16 ~ 30°C;

1.2.4 Protection function: the same as those in cooling mode;

1.2.5 In dry mode, the maximum value A of the capacity requirement percentage of single unit is 90% of that in cooling mode.

The open condition of the electronic expansion valve, outdoor fan and compressor is the same as those in cooling mode.

1.3 Heating Mode

1.3.1 Heating conditions and process:

When one of the indoor units reaches the heating operation condition, the unit starts heating operation.

1.3.2 Stop in heating operation:

1.3.2.1 When all the indoor units reach the stop condition, the compressor stops and the outdoor fan stops after 1min;

1.3.2.2 Some of the indoor units reach the stop condition

The compressor reduces the frequency immediately and operates according to the required frequency;

1.3.2.3 Heating mode transfers to cooling mode(dry mode), fan mode

a. The compressor stops; b. the power of 4-way valve is cut off after 2min; c. the outdoor fan stops after 1min; d. the status of 4-way valve: energized;

1.3.3 Outdoor fan control in heating mode

The outdoor fan starts before 5s of the starting of compressor and then it will run in high speed for 40s;

The fan shall run at every speed for at least 80s;

When the compressor stops, the outdoor fan stops after 1min.

1.3.4 Defrosting function

When the defrosting condition is met, the compressor stops; the electronic expansion valve of all indoor units open in big angle; the outdoor fan stops after 40s of the stop of compressor, meanwhile, the 4-way valve reverses the direction; after the 4-way valve reverses the direction, the compressor starts; then begin to calculate the time of defrosting, the frequency of the compressor rises to reach the defrosting frequency.

1.3.5 Oil-returned control in heating mode

1.3.5.1 Oil-returned condition

The whole unit is operating in low frequency for a long time

1.3.5.2 Oil-returned process in heating mode

The indoor unit displays "H1"

1.3.5.3 Oil-returned finished condition in heating mode

The duration reaches 5min

1.4 Fan Mode

The compressor, the outdoor fan and the 4-way valve are closed; temperature setting range is 16~30°C.

2. Protection Function

2.1 Mode Conflict Protection of indoor unit

When the setting mode is different of different indoor unit, the unit runs in below status:

- a. The mode of the first operating indoor unit is the basic mode, then compare the mode of the other indoor units to see if there is a conflict. Cooling mode (dry mode) is in conflict with heating mode.
- b. Fan mode is in conflict with heating mode and the heating mode is the basic mode. No matter which indoor unit operates first, the unit will run in heating mode.

2.2 Overload protection function

When the tube temperature is a little low, the compressor raises the operation frequency; when the tube temperature is a little high, the compressor frequency is restricted or lows down the operation frequency; when the tube temperature is too high, the compressor protection stops running.

If the discharge temperature protection continuously appears for 6 times, the compressor can't resume running. The compressor can resume running after cutting off the power and then putting through the power. (if the running time of the compressor is longer than 7min, the protection times record will be cleared)

2.3 Discharge Protection Function

When the discharge temperature is a little low, the compressor raises the operation frequency; when the discharge temperature is a little high, the compressor frequency is restricted or lows down the operation frequency; when the discharge temperature is too high, the compressor protection stops running.

If the discharge temperature protection continuously appears for 6 times, the compressor can't resume running. The compressor can resume running after cutting off the power and then putting through the power. (if the running time of the compressor is longer than 7min, the protection times record will be cleared)

2.4 Communication malfunction

Detection of the quantity of installed indoor units:

After 3min of energizing, if the outdoor unit does not receive the communication data of certain indoor unit, the outdoor unit will judge that indoor unit is not installed and will treat it as it is not installed. If the outdoor unit receives the communication data of that indoor unit later, the outdoor unit will treat that unit as it is installed.

2.5 Overcurrent Protection

a. Overcurrent protection of complete unit; b. phase wire current protection; c. compressor phase current protection

2.6 Compressor high-pressure protection

2.6.1 When the high-pressure switch is detected cut off for 3s continuously, the compressor will enter high-pressure protection as it stops when reaching set temperature. Meanwhile, the outdoor unit will send the signal of "high-pressure protection" to the indoor units;

2.6.2 After the appearance of high-pressure protection, when the high-pressure switch is detected closed for 6s continuously, the compressor can resume running only after cutting off the power and then putting through the power.

2.7 Compressor overload protection

If the compressor overload switch is detected having movement, the indoor unit will display the corresponding malfunction as it stops when the indoor temperature reaching set temperature. When the compressor stops for more than 3min and the compressor overload switch is reset, the unit will resume operation status automatically. If the protection appears for more than 6 times (if the running time of the compressor is longer than 30min, the protection times record will be cleared), the unit can not resume operation status automatically, but can resume running only after cutting off the power and then putting through the power.

2.8 Compressor Phase-lacking Protection

When the compressor starts, if one of the three phases is detected open, the compressor will enter phase-lacking protection. The malfunction will be cleared after 1min, the unit will restart and then detect if there is still has phase-lacking protection. If the phase-lacking protection is detected for 6 times continuously, the compressor will not restart but can resume running only after cutting off the power and then putting through the power. If the running time of the compressor is longer than 7min, the protection times record will be cleared.

2.9 IPM Protection

2.9.1 When the IPM module protection is detected, the unit will stop as the indoor temperature reaching set temperature, PFC is closed, display IPM protection malfunction. After the compressor stops for 3min, the unit will resume operation status automatically; if the IPM protection is detected for more than 6 times continuously (If the running time of the compressor is longer than 7min, the protection times record will be cleared), the system will stop and send the signal of module protection to indoor unit. The unit can not resume operation status automatically, but can resume running only after cutting off the power and then putting through the power.

2.9.2 IPM module overheating protection

2.9.2.1 When $T_{IPM} > 85^{\circ}\text{C}$, prohibit to raise frequency;

2.9.2.2 When $T_{IPM} \geq 90^{\circ}\text{C}$, the operation frequency of compressor lows down by 15% every 90s according to the present capacity requirement of the complete unit. It will keep 90s after lowing down the frequency. After lowing down the frequency, if $T_{IPM} \geq 90^{\circ}\text{C}$, the unit will circulate the above movement until reaching the minimum frequency; if $85^{\circ}\text{C} < T_{IPM} < 90^{\circ}\text{C}$, the unit will run at this frequency; when $T_{IPM} \leq 85^{\circ}\text{C}$, the unit will run at the frequency according to the capacity requirement;

2.9.2.3 When $T_{IPM} \geq 95^{\circ}\text{C}$, the compressor stops. After the compressor stops for 3min, if $T_{IPM} < 85^{\circ}\text{C}$, the compressor and the outdoor fan will resume operation.

Part II : Installation and Maintenance

7. Notes for Installation and Maintenance

Safety Precautions: Important!

Please read the safety precautions carefully before installation and maintenance.

The following contents are very important for installation and maintenance.

Please follow the instructions below.

- The installation or maintenance must accord with the instructions.
- Comply with all national electrical codes and local electrical codes.
- Pay attention to the warnings and cautions in this manual.
- All installation and maintenance shall be performed by distributor or qualified person.
- All electric work must be performed by a licensed technician according to local regulations and the instructions given in this manual.
- Be caution during installation and maintenance. Prohibit incorrect operation to prevent electric shock, casualty and other accidents.



Warnings

Electrical Safety Precautions:

1. Cut off the power supply of air conditioner before checking and maintenance.
2. The air condition must apply specialized circuit and prohibit share the same circuit with other appliances.
3. The air conditioner should be installed in suitable location and ensure the power plug is touchable.
4. Make sure each wiring terminal is connected firmly during installation and maintenance.
5. Have the unit adequately grounded. The grounding wire can't be used for other purposes.
6. Must apply protective accessories such as protective boards, cable-cross loop and wire clip.
7. The live wire, neutral wire and grounding wire of power supply must be corresponding to the live wire, neutral wire and grounding wire of the air conditioner.
8. The power cord and power connection wires can't be pressed by hard objects.
9. If power cord or connection wire is broken, it must be replaced by a qualified person.

10. If the power cord or connection wire is not long enough, please get the specialized power cord or connection wire from the manufacture or distributor. Prohibit prolong the wire by yourself.

11. For the air conditioner without plug, an air switch must be installed in the circuit. The air switch should be all-pole parting and the contact parting distance should be more than 3m.

12. Make sure all wires and pipes are connected properly and the valves are opened before energizing.

13. Check if there is electric leakage on the unit body. If yes, please eliminate the electric leakage.

14. Replace the fuse with a new one of the same specification if it is burnt down; don't replace it with a cooper wire or conducting wire.

15. If the unit is to be installed in a humid place, the circuit breaker must be installed.

Installation Safety Precautions:

1. Select the installation location according to the requirement of this manual.(See the requirements in installation part)
2. Handle unit transportation with care; the unit should not be carried by only one person if it is more than 20kg.
3. When installing the indoor unit and outdoor unit, a sufficient fixing bolt must be installed; make sure the installation support is firm.
4. Ware safety belt if the height of working is above 2m.
5. Use equipped components or appointed components during installation.
6. Make sure no foreign objects are left in the unit after finishing installation.

Refrigerant Safety Precautions:

1. Avoid contact between refrigerant and fire as it generates poisonous gas; Prohibit prolong the connection pipe by welding.
2. Apply specified refrigerant only. Never have it mixed with any other refrigerant. Never have air remain in the refrigerant line as it may lead to rupture or other hazards.
3. Make sure no refrigerant gas is leaking out when installation is completed.
4. If there is refrigerant leakage, please take sufficient measure to minimize the density of refrigerant.
5. Never touch the refrigerant piping or compressor without wearing glove to avoid scald or frostbite.

Improper installation may lead to fire hazard, explosion, electric shock or injury.

Main Tools for Installation and Maintenance

<p>1. Level meter, measuring tape</p> 	<p>2. Screw driver</p> 	<p>3. Impact drill, drill head, electric drill</p> 
<p>4. Electroprobe</p> 	<p>5. Universal meter</p> 	<p>6. Torque wrench, open-end wrench, inner hexagon spanner</p> 
<p>7. Electronic leakage detector</p> 	<p>8. Vacuum pump</p> 	<p>9. Pressure meter</p> 
<p>10. Pipe pliers, pipe cutter</p> 	<p>11. Pipe expander, pipe bender</p> 	<p>12. Soldering appliance, refrigerant container</p> 

8. Installation Manual

Installation procedures

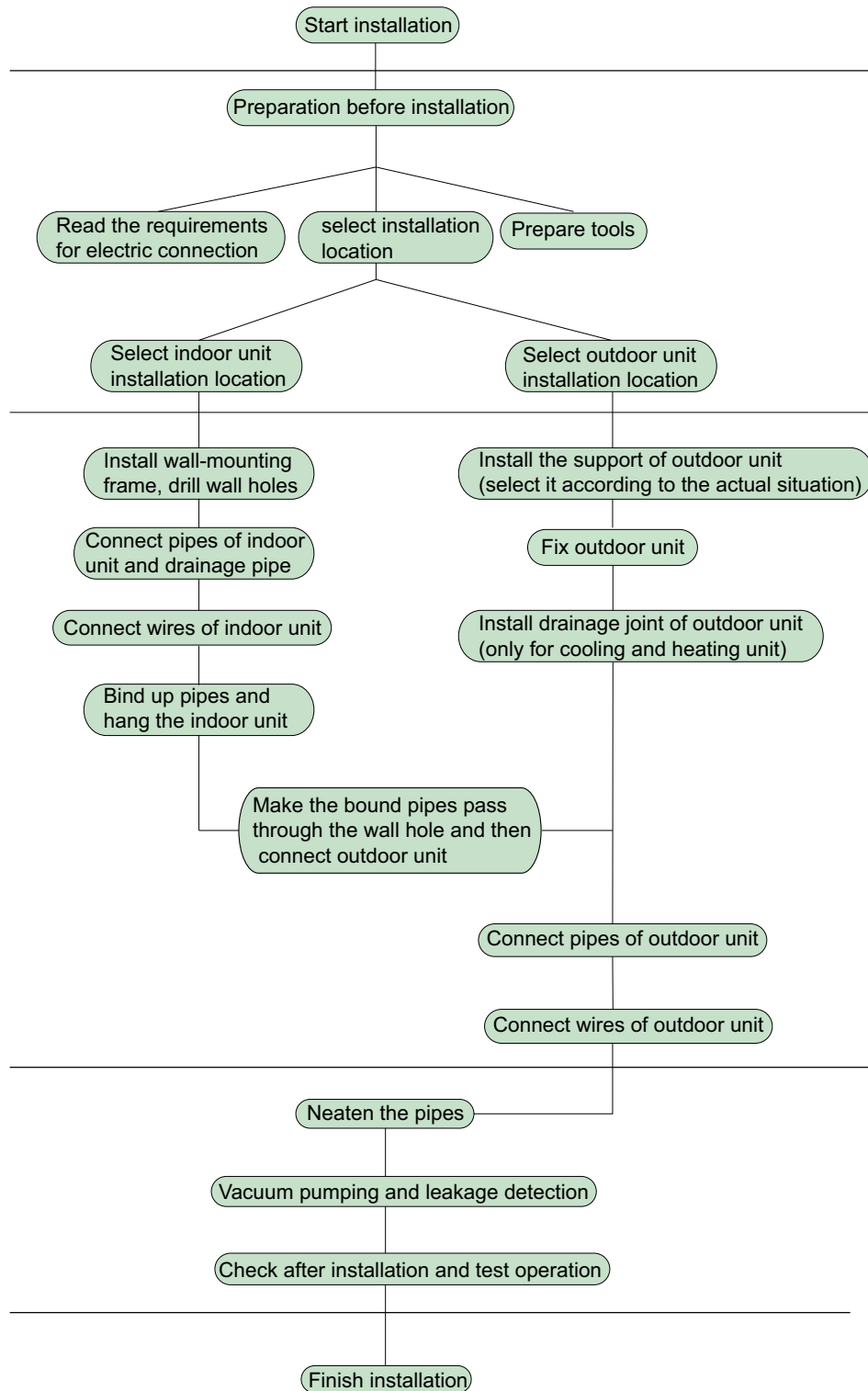

Note: this flow is only for reference; please find the more detailed installation steps in this section.

8.1 Electrical Connections

MS-E14AIN, MS-E18AIN

1. Remove the handle at the right side plate of the outdoor unit (one screw).
2. Remove the cable clamp, connect the power connection cable with the terminal at the row of connection and fix the connection. The fitting line distributing must be consistent with the indoor unit. terminal of line bank. Wiring should meet that of indoor unit.
3. Fix power connection wire by wire clamp.
4. Ensure wire has been fixed well.
5. Install the handle.

! Including an air switch with suitable capacity, please note the following table. Air switch should be included magnet buckle and heating buckle function, it can protect the circuit-short and overload. (Caution: please do not use the fuse only for protect the circuit)

Air-conditioner	Air switch capacity
MS-E14AIN	10A
MS-E18AIN	10A

! An all-pole disconnection switch having a contact separation of at least 3mm in all pole should be connected in fixed wiring.

! Wrong wire connection may cause malfunction of some electric components. After fixing cable, ensure that leads between connection to fixed point have some space.

! The connection pipes and the connecting wirings of the unit A and unit B must be corresponding to each other respective.

! The appliance shall be installed in accordance with national wiring regulations.

Note: the above figures are only intended to be a simple diagram of the appliance and may not correspond to the appearance of the units that have been purchased.

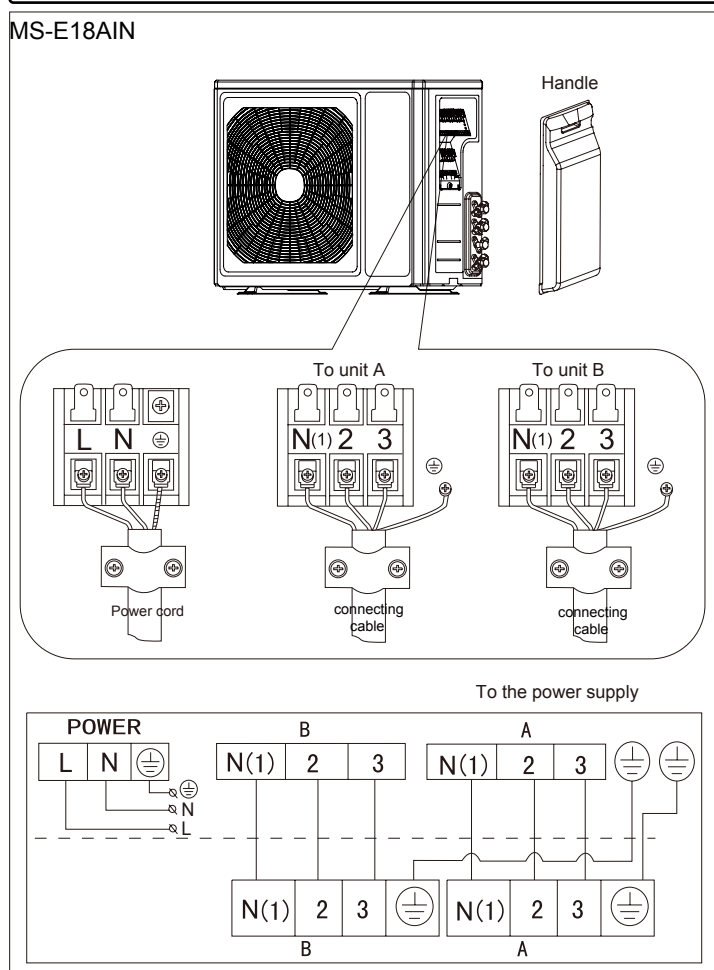
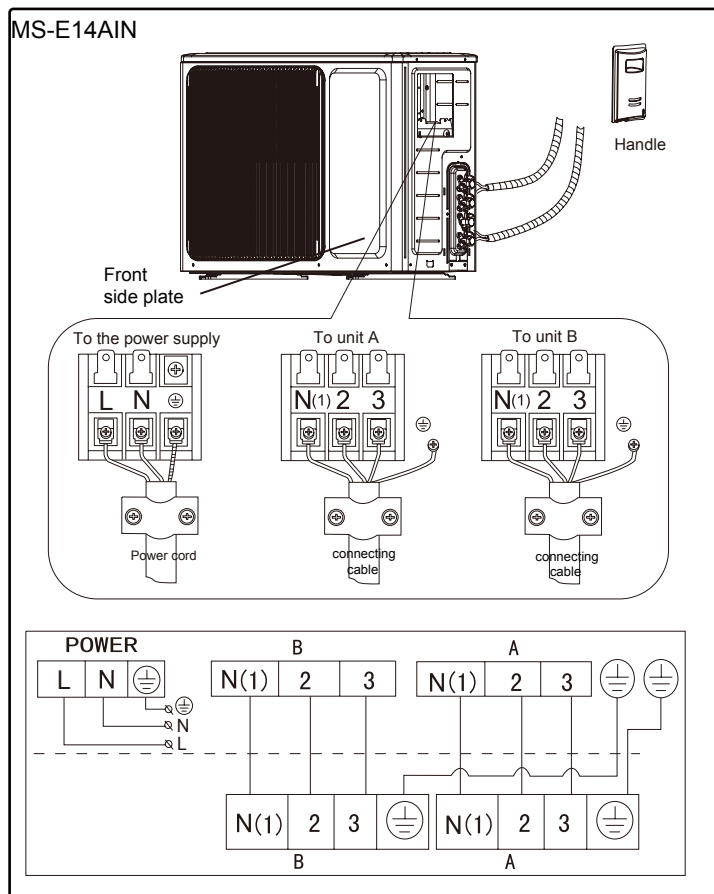

MS-E21AIN, MS-E24AIN

1. Remove the handle at the right side plate of the outdoor unit (one screw).
2. Remove the cable clamp, connect the power connection cable with the terminal at the row of connection and fix the connection. The fitting line distributing must be consistent with the indoor unit. terminal of line bank. Wiring should meet that of indoor unit.
3. Fix power connection wire by wire clamp.
4. Ensure wire has been fixed well.
5. Install the handle.

Including an air switch with suitable capacity, please note the following table. Air switch should be included magnet buckle and heating buckle function, it can protect the circuit-short and overload. (Caution: please do not use the fuse only for protect the circuit)

Air-conditioner	Air switch capacity
MS-E21AIN	25A
MS-E24AIN	25A

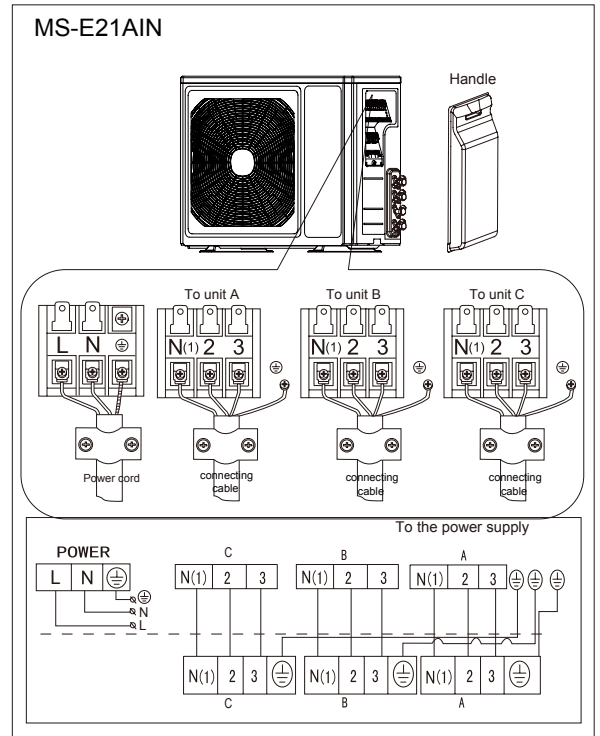

! An all-pole disconnection switch having a contact separation of at least 3mm in all pole should be connected in fixed wiring.

Wrong wire connection may cause malfunction of some electric components. After fixing cable, ensure that leads between connection to fixed point have some space.

The connection pipes and the connecting wirings of the unit A, unit B, unit C and unit D must be corresponding to each other respective.

The appliance shall be installed in accordance with national wiring regulations.

Note: The above figures are only intended to be a simple diagram of the appliance and may not correspond to the appearance of the units that have been purchased.

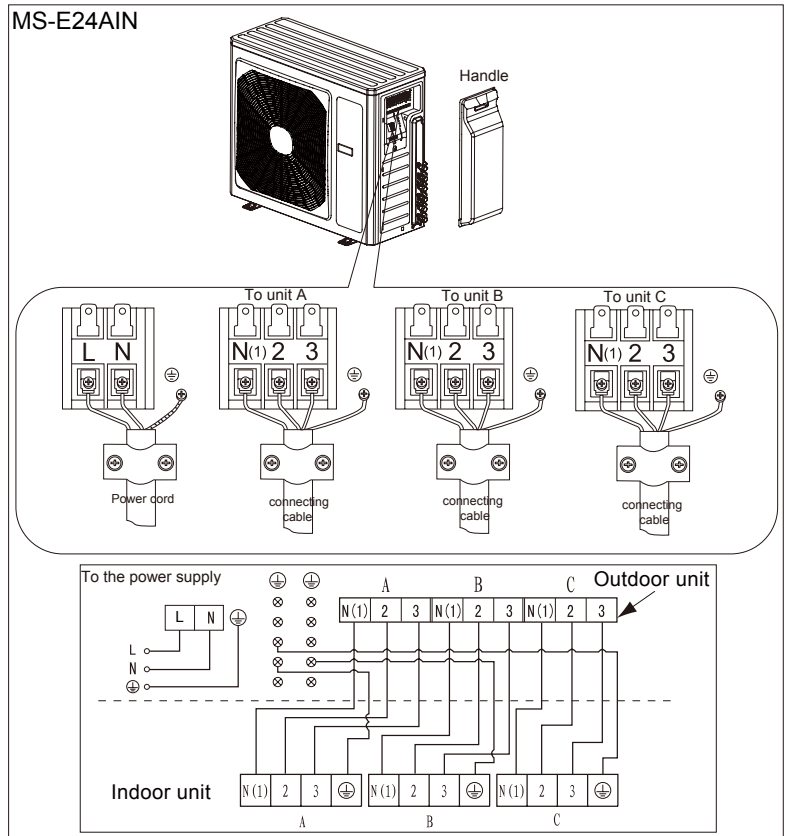

MS-E28AIN

1. Remove the handle at the right side plate of the outdoor unit (one screw).
2. Remove the cable clamp, connect the power connection cable with the terminal at the row of connection and fix the connection. The fitting line distributing must be consistent with the indoor unit. terminal of line bank. Wiring should meet that of indoor unit.
3. Fix power connection wire by wire clamp.
4. Ensure wire has been fixed well.
5. Install the handle.

Including an air switch with suitable capacity, please note the following table. Air switch should be included magnet buckle and heating buckle function, it can protect the circuit-short and overload. (Caution: please do not use the fuse only for protect the circuit)

Air-conditioner	Air switch capacity
MS-E28AIN	25A

An all-pole disconnection switch having a contact separation of at least 3mm in all pole should be connected in fixed wiring.

Wrong wire connection may cause malfunction of some electric components. After fixing cable, ensure that leads between connection to fixed point have some space.

The connection pipes and the connecting wirings of the unit A, unit B, unit C and unit D must be corresponding to each other respective.

The appliance shall be installed in accordance with national wiring regulations.

Note: The above figures are only intended to be a simple diagram of the appliance and may not correspond to the appearance of the units that have been purchased.

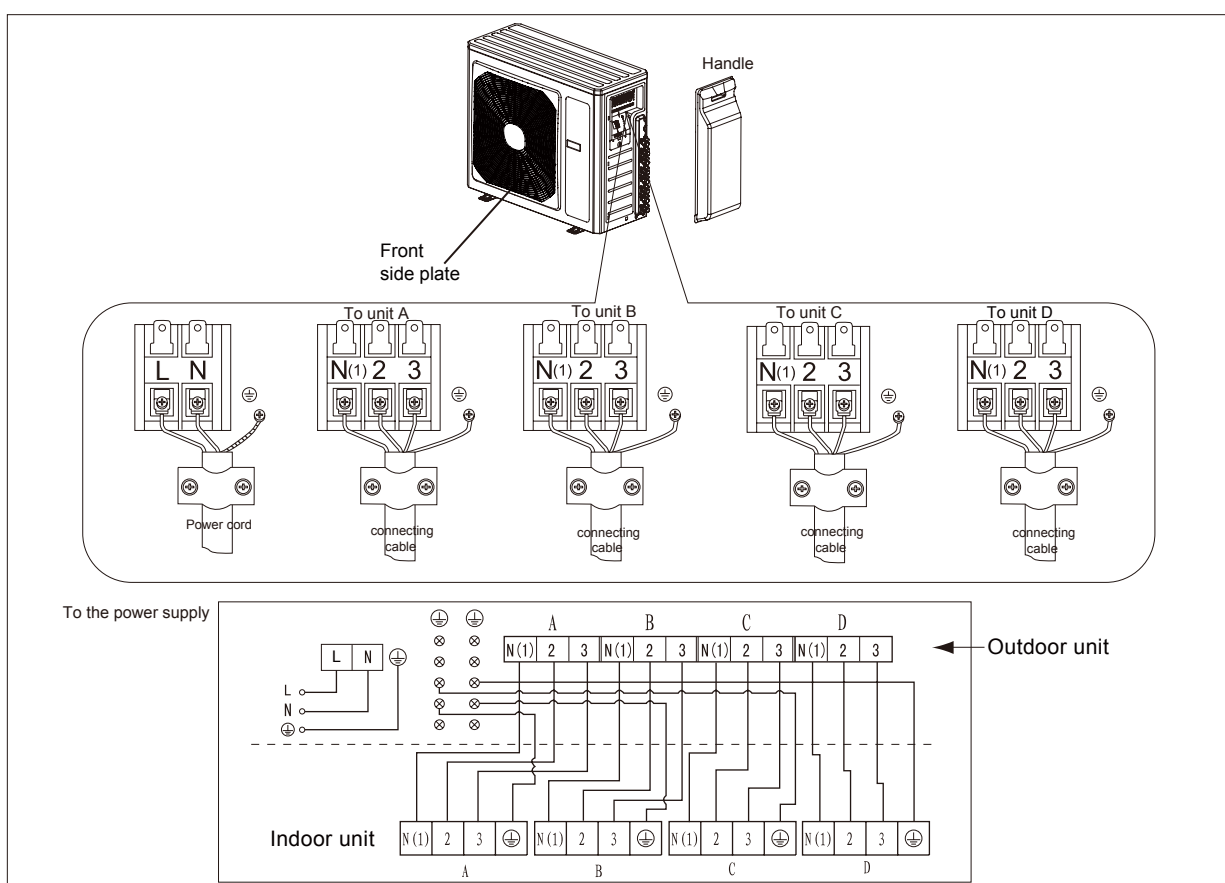

8.2 Installing the Outdoor Unit

- ⚠ Do not install the outdoor unit in pits or air vents
- When mounting the unit on a wall or the roof, make sure the support is firmly secured so that it cannot move in the event of intense vibrations or a strong wind.

Installing the pipes

- ⚠ Use suitable connecting pipes and equipment for the refrigerant R410A.

Models(m)	14/18K	21/24K	28K
Max. connection pipe length	20	60	70
Max. connection pipe length(Simpleone indoor unit)	10	20	20

The sum of the capacity codes of the indoor units should be among 50%-150% of that of the outdoor unit.

- ⚠ The refrigerant pipes must not exceed the maximum heights 5m(14K&18K)or 10m(21K, 24K, 28K).
- ⚠ Wrap all the refrigerant pipes and joints.
- ⚠ Tighten the connections using two wrenches working in opposite directions.by Authorized Personnel Only.

Caution: Installation Must be Performed in Accordance with the NEC/CEC by Authorized Personnel Only.

Humid air left inside the refrigerant circuit can cause compressor malfunction. After having connected the indoor and outdoor units, bleed the air and humidity from the refrigerant circuit using a vacuum pump.

- Unscrew and remove the caps from the 2-way and 3-way valves.
- Unscrew and remove the cap from the service valve.
- Connect the vacuum pump hose to the service valve.
- Operate the vacuum pump for 10-15 minutes until an absolute vacuum of 10 mm Hg has been reached.
- With the vacuum pump still in operation, close the low-pressure knob on the vacuum pump coupling. Stop the vacuum pump.
- Open the 2-way valve by 1/4 turn and then close it after 10 seconds. Check all the joints for leaks using liquid soap or an electronic leak device.
- Turn the body of the 2-way and 3-way valves. Disconnect the vacuum pump hose.
- Replace and tighten all the caps on the valves.

Diameter (mm)	Twisting moment (N.m)
Φ6	15-20
Φ9.52	35-40
Φ16	60-65
Φ12	45-50
Φ19	70-75

- If the specification of outdoor unit gas valve is 3/8",but customer needs to install 1/2"indoor unit so that it is need to use a "pipe joint subassembly" (Code 06643008) to make a conversion joint with outdoor unit gas valve and connection pipe, as show in following.

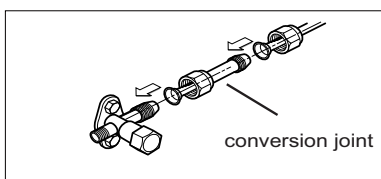

Install the drain fitting and the drain hose(for model with heat pump only)

Condensation is produced and flows from the outdoor unit when the appliance is operating in the heating mode. In order not to disturb neighbours and to respect the environment, install a drain fitting and a drain hose to channel the condensate water. Install the drain fitting and rubber washer on the outdoor unit chassis and connect a drain hose to it as shown in the figure.

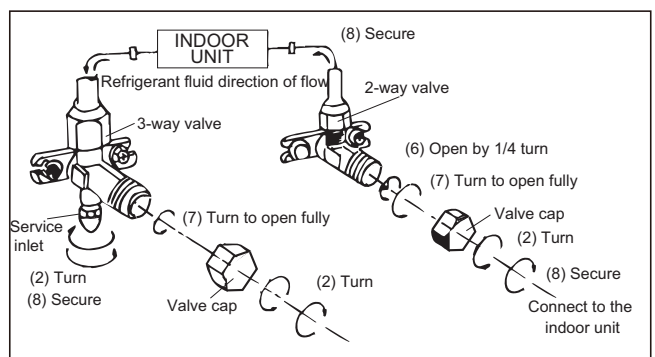
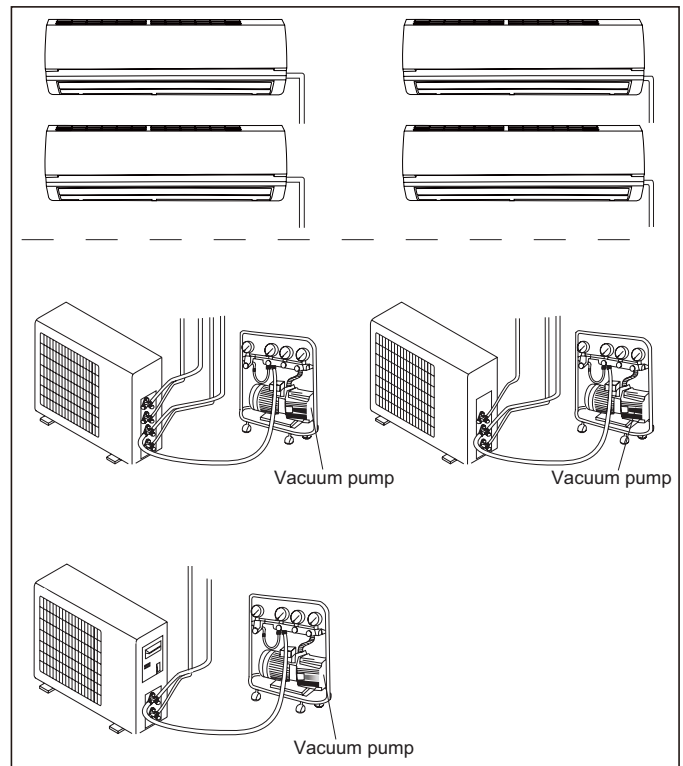
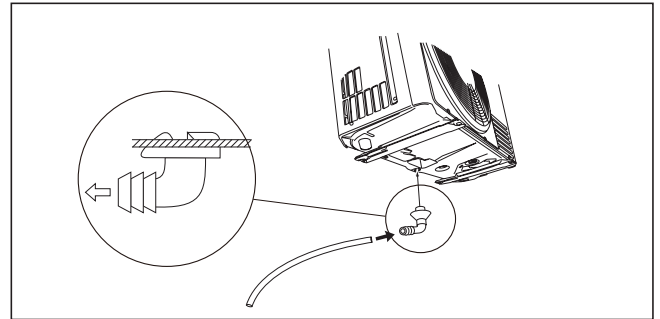



8.3 Installation Dimension Diagram

 Use suitable instruments for the refrigerant R410A.

- Do not use any other refrigerant than R410A.

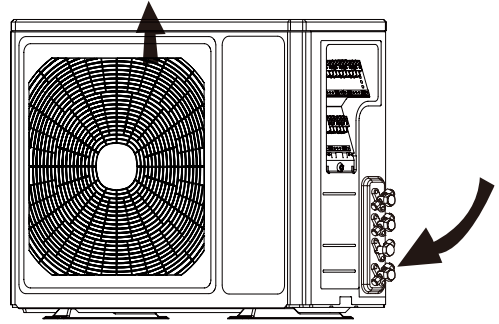
 Do not use mineral oils to clean the unit.



 The installation must be done by trained and qualified service personnel with reliability according to this manual.

 Contact service center before installation to avoid the malfunction due to unprofessional installation.

 When picking up and moving the units, you must be guided by trained and qualified person.

 Ensure that the recommended space is left around the appliance.

18/21K

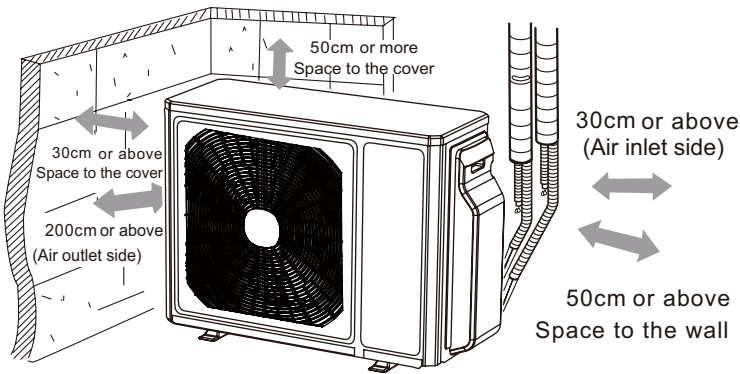

24/28K

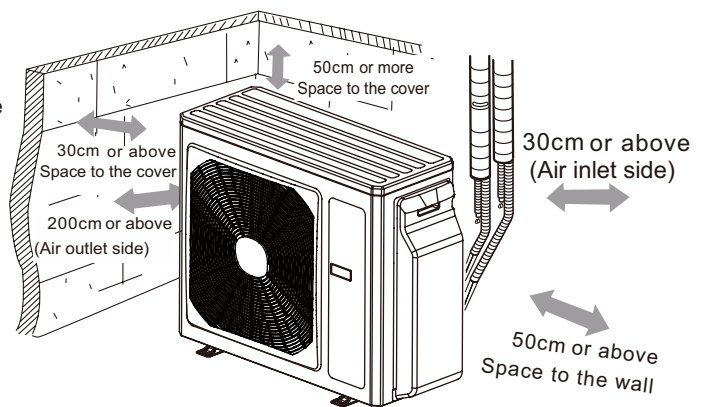

14K

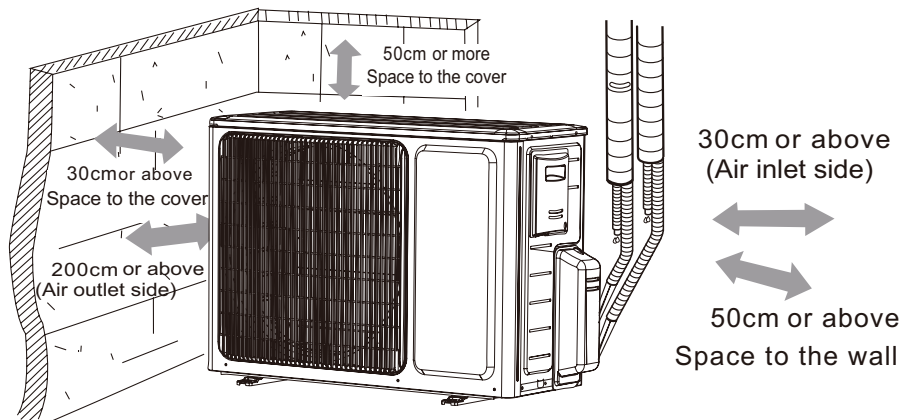

8.4 Check after Installation

Check Items	Problems Owing to Improper Installation
Is the installation reliable?	The unit may drop, vibrate or make noises
Has the gas leakage been checked?	May cause unsatisfactory cooling (heating) effect
Is the thermal insulation of the unit sufficient?	May cause condensation and water dropping
Is the drainage smooth?	May cause condensation and water dropping
Does the power supply voltage accord with the rated voltage specified on the nameplate?	The unit may bread down or the components may be burned out
Are the lines and pipelines correctly installed?	The unit may bread down or the components may be burned out
Has the unit been safely grounded?	Risk of electrical leakage
Are the models of lines in conformity with requirements?	The unit may bread down or the components may be burned out
Are there any obstacles near the air inlet and outlet of the indoor and outdoor units?	The unit may bread down or the components may be burned out
Have the length of refrigerating pipe and refrigerant charge amount been recorded?	It is not easy to decide the charge amount of refrigerant.

9. Maintenance

9.1 Precautions before Performing Inspection or Repair

There are high-capacity electrolytic capacitors on the outdoor mainboard. Thus, even the power is cut off, there is high voltage inside the capacitors and it needs more than 20min to reduce the voltage to safety value. Touching the electrolytic capacitor within 20min after cutting the power will cause electric shock. If maintenance is needed, follow the steps below to discharge electricity of electrolytic capacitor after power off.

(1) Open the top cover of outdoor unit and then remove the cover of electric box cover.

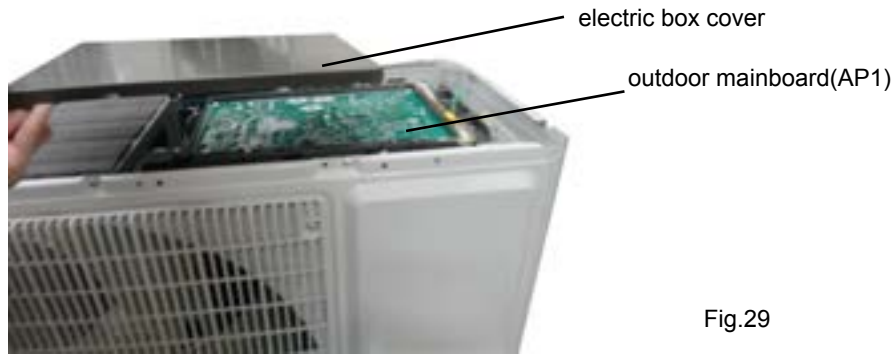

Fig.29

(2) As shown in the fig below, connect the plug of discharge resistance (about 100ohm, 20W) (if there is no discharge resistance, you can use the plug of soldering iron) to point A and B of electrolytic capacitor. There will be sparks when touching them. Press them forcibly for 30s to discharge electricity of electrolytic capacitor.



Fig.30

(3) After finish discharging electricity, measure the voltage between point A and B with universal meter to make sure if electricity discharging is completed, in order to prevent electric shock. If the voltage between the two points is below 20V, you can perform maintenance safely.

9.2 Flashing LED of Indoor/Outdoor Unit and Primary Judgement

1. Requirement of malfunction display

When several malfunctions happen at the same time, malfunction codes will be displayed circularly.

2. Malfunction display method

(1) Hardware malfunction: it will be displayed immediately, please refer to "Malfunction status sheet";

(2) Operation status: it will be displayed immediately, please refer to "Malfunction status sheet";

(3) Other malfunction: It will be displayed after the compressor has been stopped for 200s, please refer to "Malfunction status sheet".

(Note: when the compressor starts up again, malfunction display waiting time (200s) will be cleared.)

3. Malfunction display control

Indoor unit displays malfunction code as shown in the sheet below. ODU communication light will be off for 1s and then blink for 1s circularly.

4. Viewing malfunction code through remote controller

Enter viewing malfunction code: pressing light button for 6 times within 3S to view malfunction code;

Exit viewing malfunction code: pressing light button for 6 times within 3S or after the malfunction code is displayed for 5min.

Malfunction status sheet		
Malfunction name	Malfunction type	Nixie tube
Zero cross detection circuit malfunction	Hardware malfunction	U8
Malfunction protection of jumper cap	Hardware malfunction	C5
Feedback of without IDU motor	Hardware malfunction	H6
Indoor ambient temperature sensor is open/short circuited	Hardware malfunction	F1
Indoor evaporator temperature sensor is open/short circuited	Hardware malfunction	F2
Liquid valve temperature sensor is open/short circuited	Hardware malfunction	b5
Gas valve temperature sensor is open/short circuited	Hardware malfunction	b7
Modular temperature sensor is open/short circuited	Hardware malfunction	P7
Outdoor ambient temperature sensor is open/short circuited	Hardware malfunction	F4
Outdoor condenser inlet pipe temperature sensor is open/short circuited (commercial)	Hardware malfunction	A5
Outdoor condenser middle pipe temperature sensor is open/short circuited	Hardware malfunction	F4
Outdoor condenser outlet pipe temperature sensor is open/short circuited (commercial)	Hardware malfunction	A7
Outdoor discharge temperature sensor is open/short circuited	Hardware malfunction	F5
Communication malfunction	Hardware malfunction	E6
Malfunction of phase current detection circuit for compressor	Hardware malfunction	U1
Compressor demagnetization protection	Viewing malfunction code through remote controller within 200s; displayed directly on nixietube after 200s	HE
Malfunction of voltage dropping for DC bus-bar		U3
Module high temperature protection		P8
Refrigerant lacking or blockage protection of system (not available for residential ODU)		F0
Charging malfunction of capacitor	Hardware malfunction	PU
High pressure protection of system	Hardware malfunction	E1
Low pressure protection of system (reserved)	Hardware malfunction	E3

Compressor overload protection	Viewing malfunction code through remote controller within 200s; displayed directly on nixietube after 200s	H3
Indoor unit and outdoor unit do not match	Hardware malfunction	LP
Malfunction of memory chip	Hardware malfunction	EE
Wrong connection of communication wire or malfunction of electronic expansion valve	Hardware malfunction	dn
Malfunction of complete units current detection	Hardware malfunction	U5
Malfunction protection of outdoor fan 1	Hardware malfunction	L3
Detection status of wrong connection of communication wire or malfunction of electronic expansion valve	Operation status	dd
Mode conflict	Operation status	E7
Refrigerant recycling mode	Operation status	Fo
X-fan	Operation status	AL
Defrosting or oil return in heating mode	Operation status	H1
Start failure of compressor	Viewing malfunction code through remote controller within 200s; displayed directly on nixietube after 200s	Lc
High discharge temperature protection of compressor		E4
Overload protection		E8
Whole unit overcurrent protection		E5
Compressor phase current protection		P5
Compressor desynchronizing		H7
Compressor phase-lacking/phase-inverse protection		Ld
IPM modular protection		H5
DC bus-bar low voltage protection		PL
DC bus-bar high voltage protection		PH
PFC protection		HC
The four-way valve is abnormal		U7

9.3 Malfunction Checking and Elimination **H5**

1 IPM protection malfunction:

Main checking point:

- If the input voltage of the unit is within normal range?
- If the connection wire of compressor is connected well? Is it loose? If the connection sequence is correct?
- If the resistance of compressor coil is normal? If the isolation of compressor coil with copper pipe is good?
- If the unit is overloaded? If the heat radiation of the unit is good?
- If the refrigerant charge is suitable?

Flow chart:

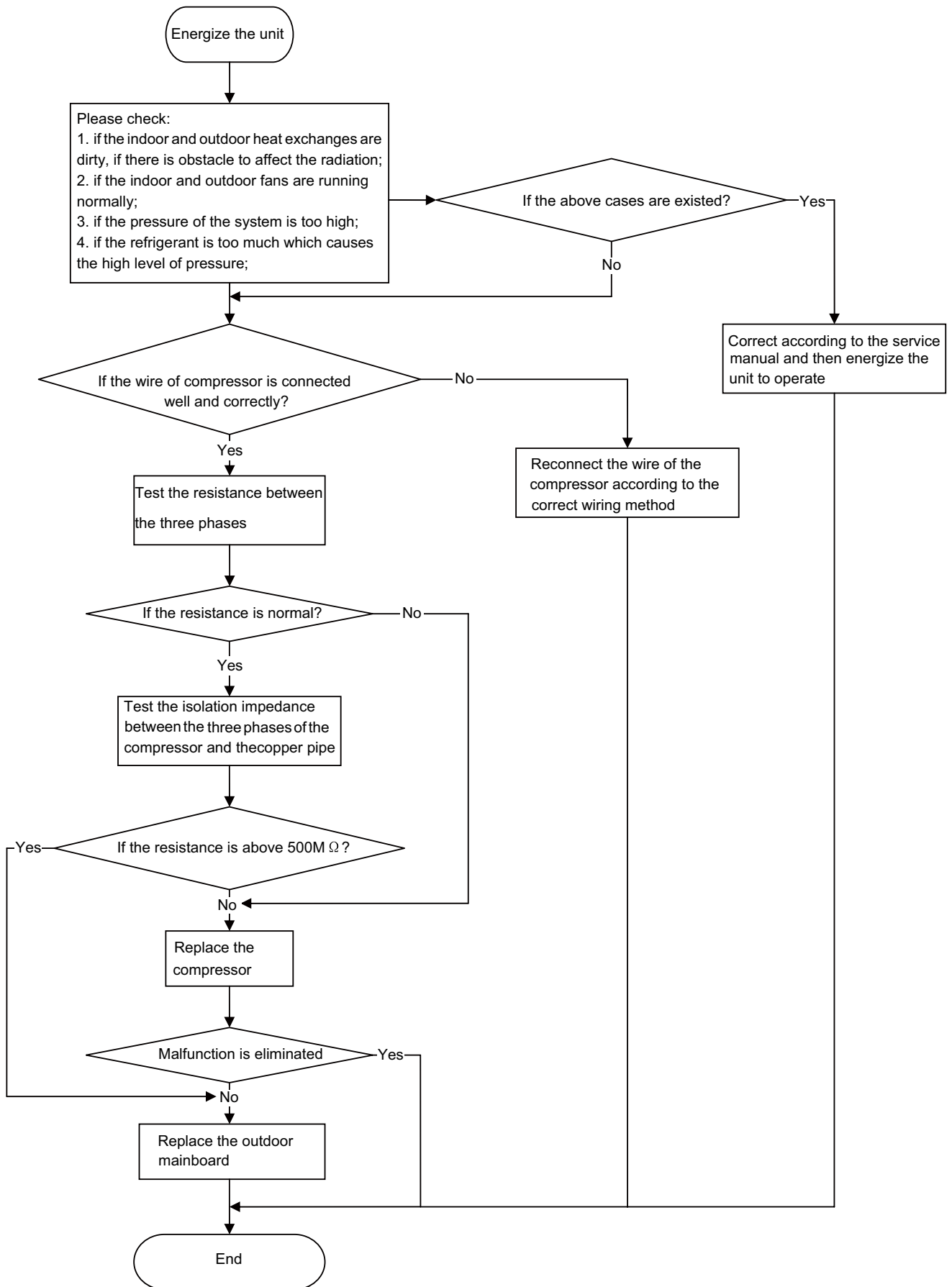

2. PFC protection malfunction, capacity charging malfunction

HC

Main checking points:

- If the wiring of the induction is connected well and if the induction is broken;
- If the mainboard is broken;

Flow chart:

For 14/18K

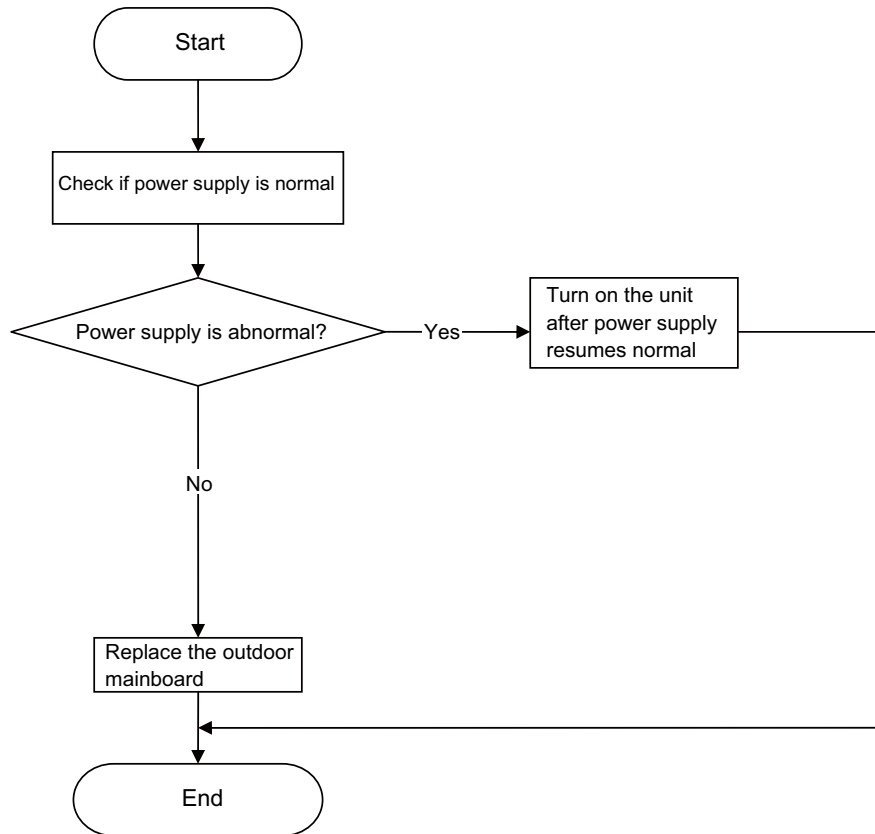

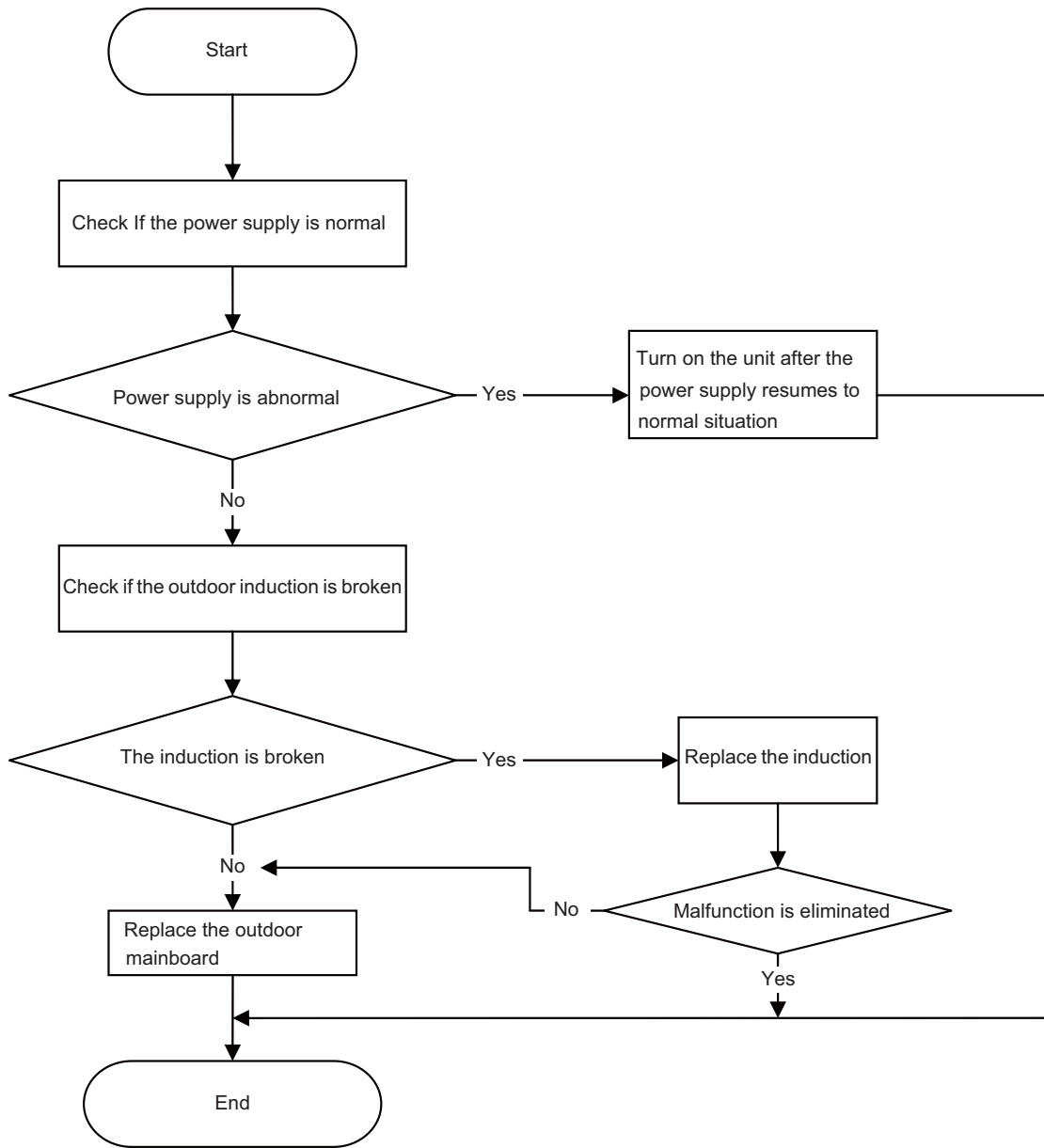

3. Compressor desynchronizing malfunction

H7

Main checking points:

- If the pressure of the system is too high;
- If the electric expansion valve is working normally or it is broken;
- If the radiation of the unit is good;

Flow chart:



H7

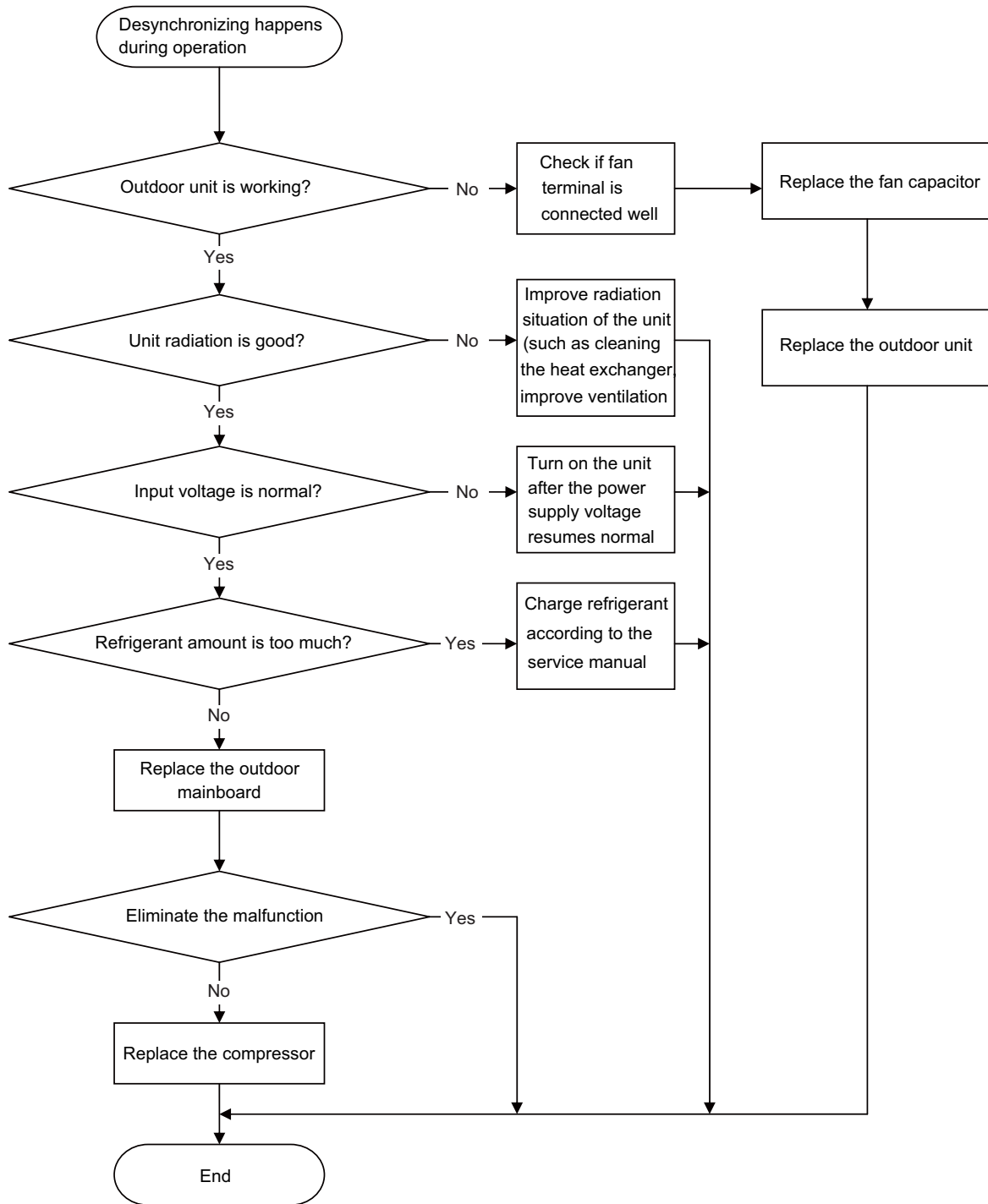

4. Compressor overload, discharge protection malfunction

E4, E8

Main checking points:

- If the electric expansion valve is connected well or it is broken;
- If there is refrigerant leakage;
- If the overload protector is broken;

Flow chart:

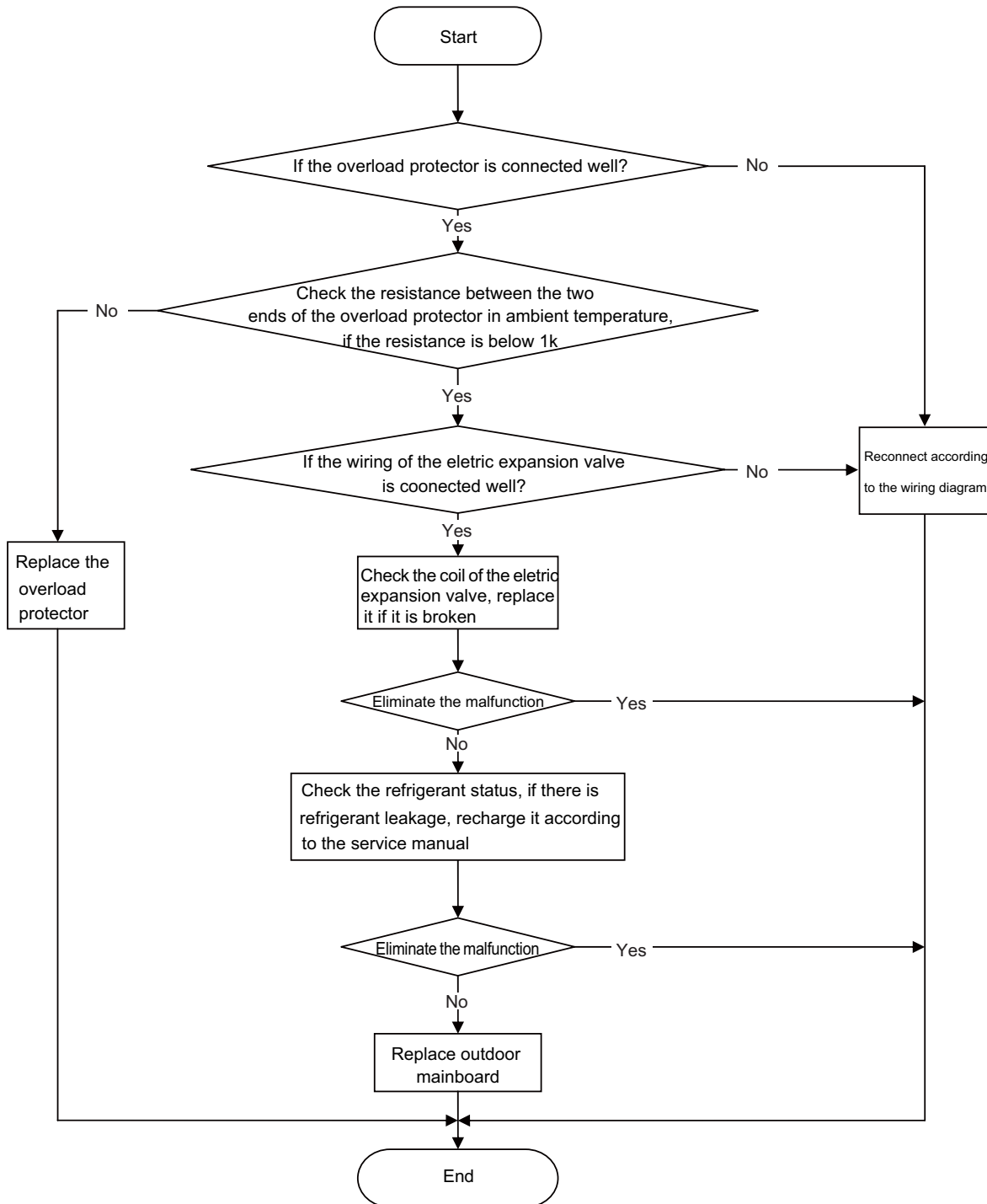

Note: the detection method of the coil of the electric expansion valve: there is five pieces of coil of the electric expansion valve, the resistance of one of them (the leftmost or the rightmost one) is almost the same as the resistance of other terminal (within 100 Ω). Judge the condition of the electronic expansion valve through detecting these resistance.

5. Start failure malfunction

Main checking points:

- If the connection wire of the compressor is connected properly;
- If the stop duration of the compressor is sufficient;
- If the compressor is broken;
- If the refrigerant charging amount is too much;

Flow chart:

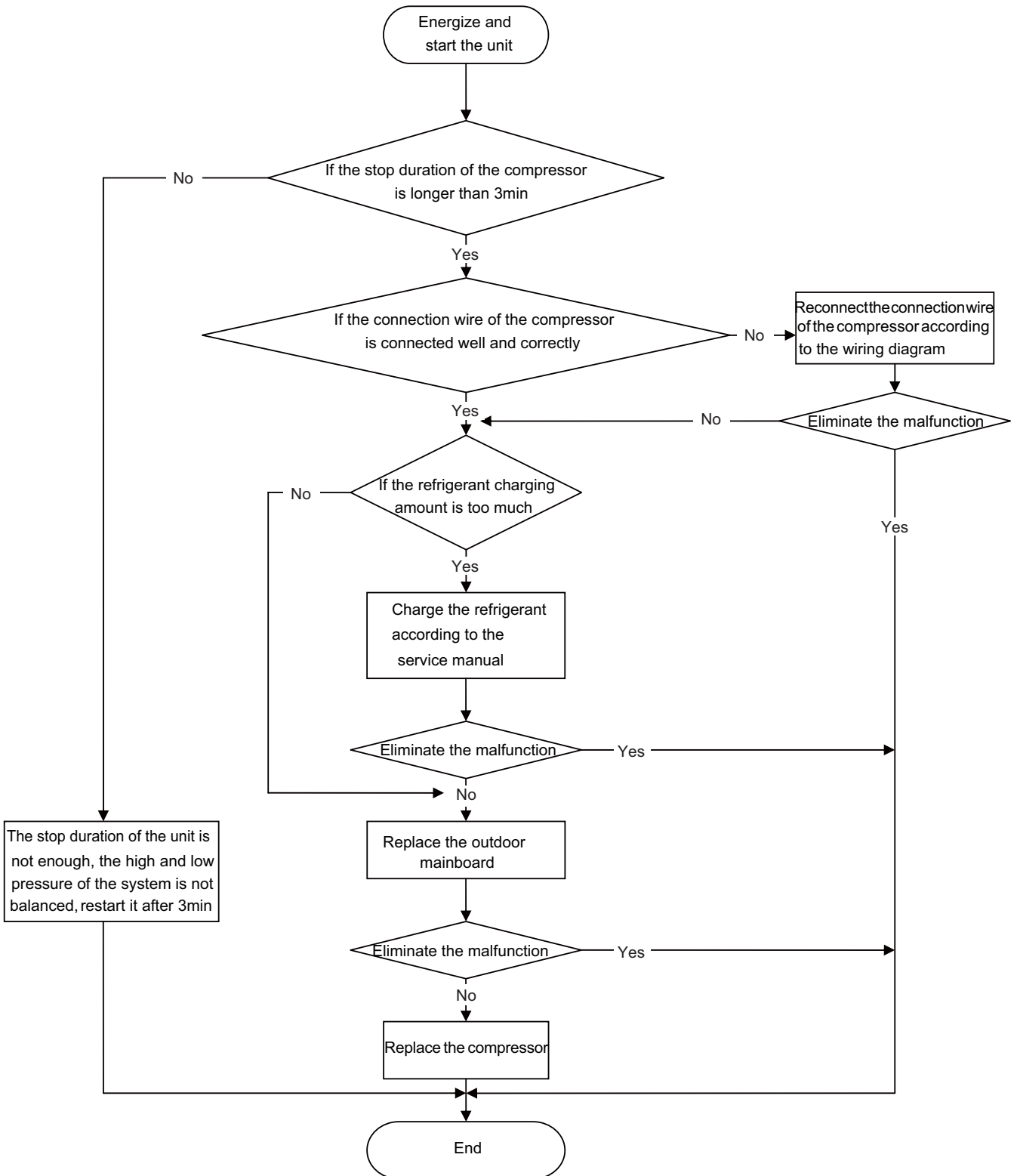

6. Temperature sensor malfunction

F1-5

Main checking points:

- If the temperature sensor is damaged or broken
- If the terminal of the temperature sensor is loosened or not connected;
- If the mainboard is broken;

Flow chart:

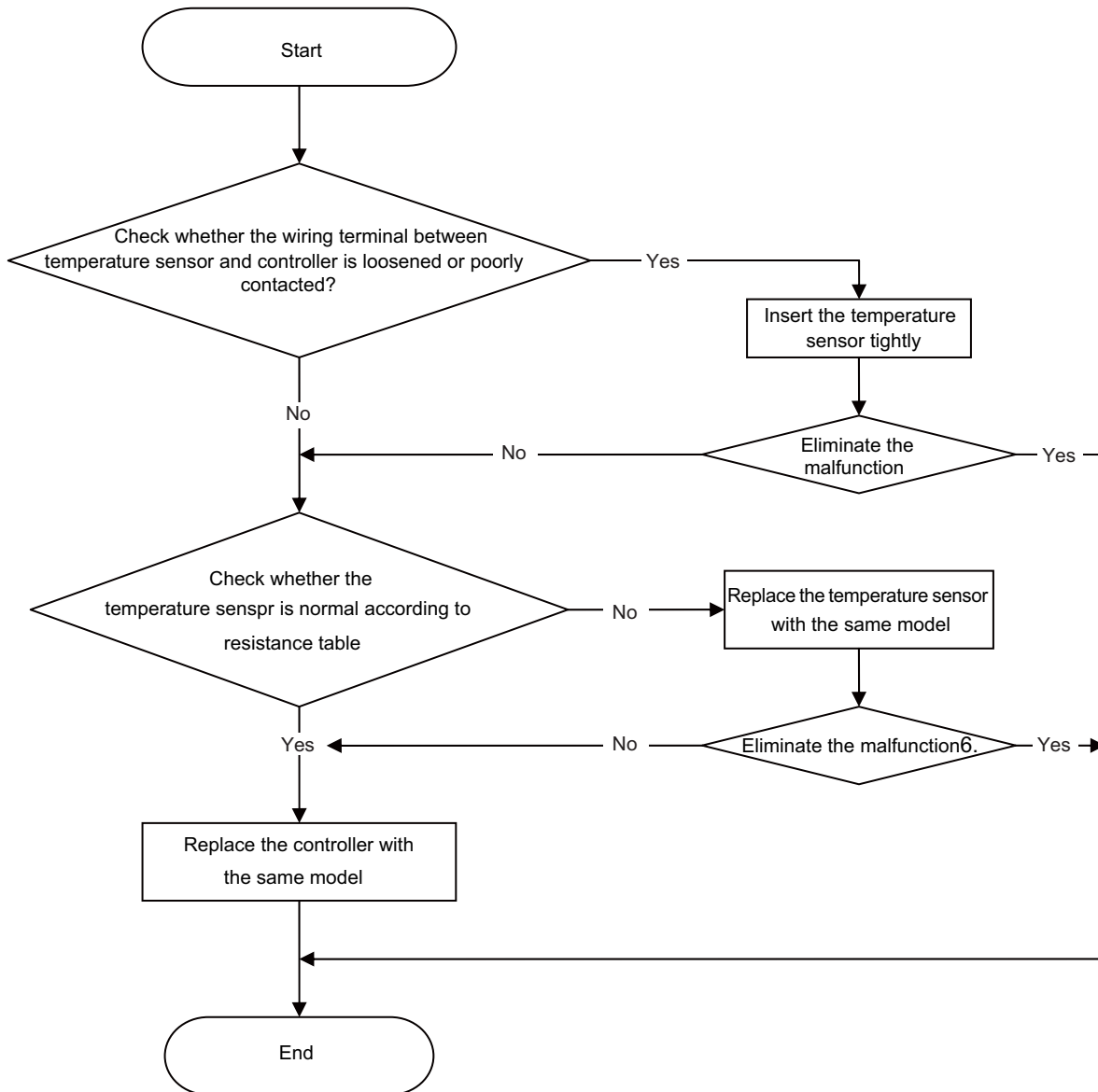

7. DC fan malfunction

Main checking points:

- If the outdoor fan is blocked by foreign objects;
- The connection wire of DC fan is connected reliably? If it is loose?

Flow chart:

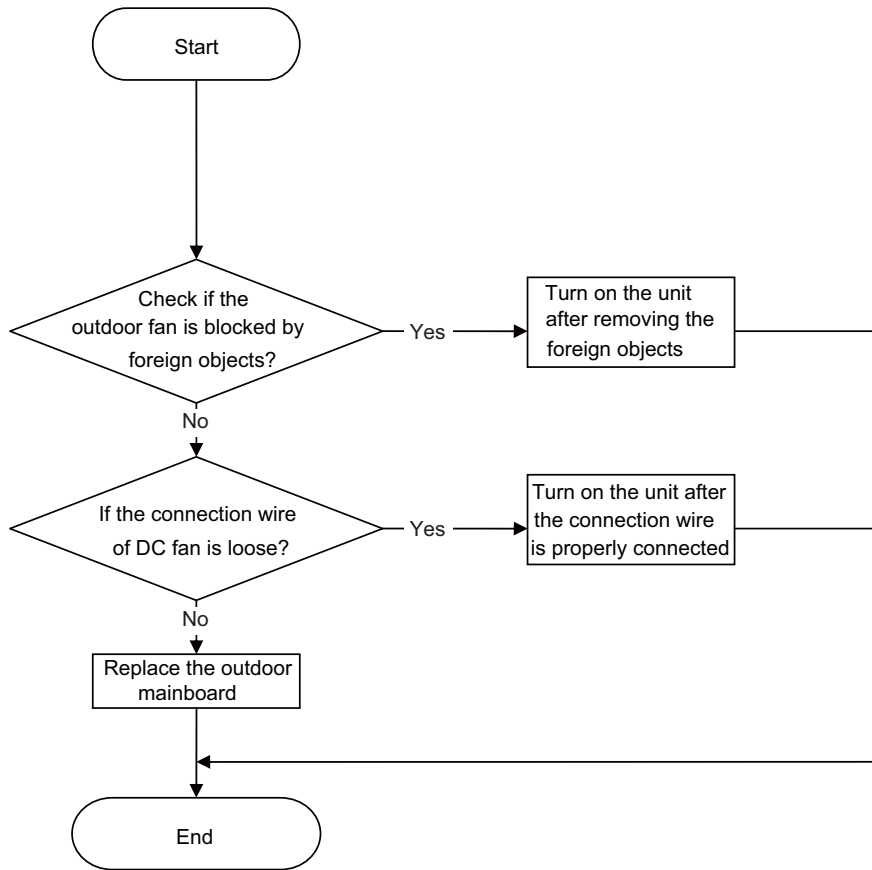

8. Communication malfunction

E6

Main checking points:

- If the connection wire between the indoor unit and outdoor unit is connected well, if the wires inside the unit is connected well;
- If the indoor mainboard or outdoor main board is broken;

Flow chart:

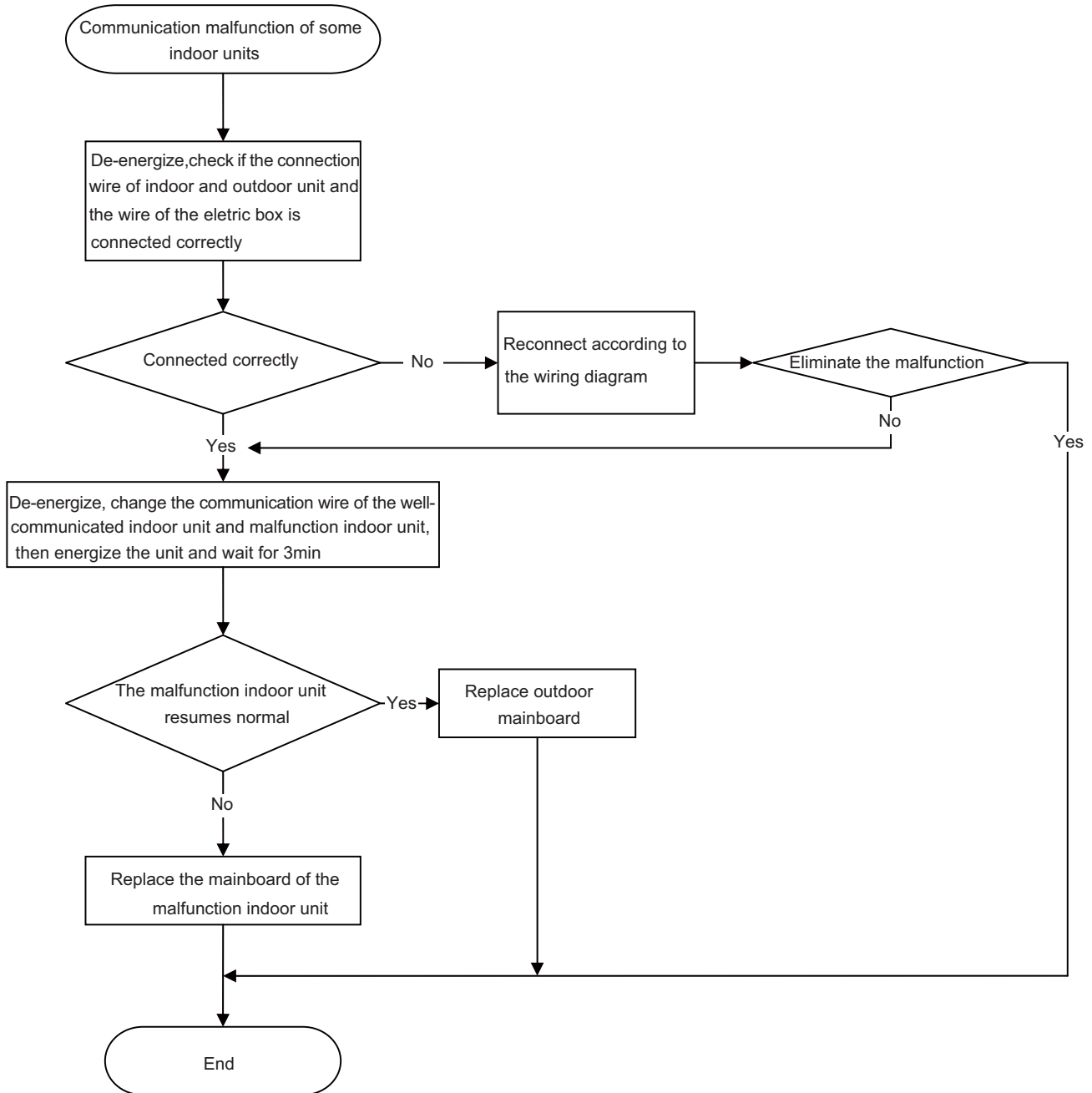

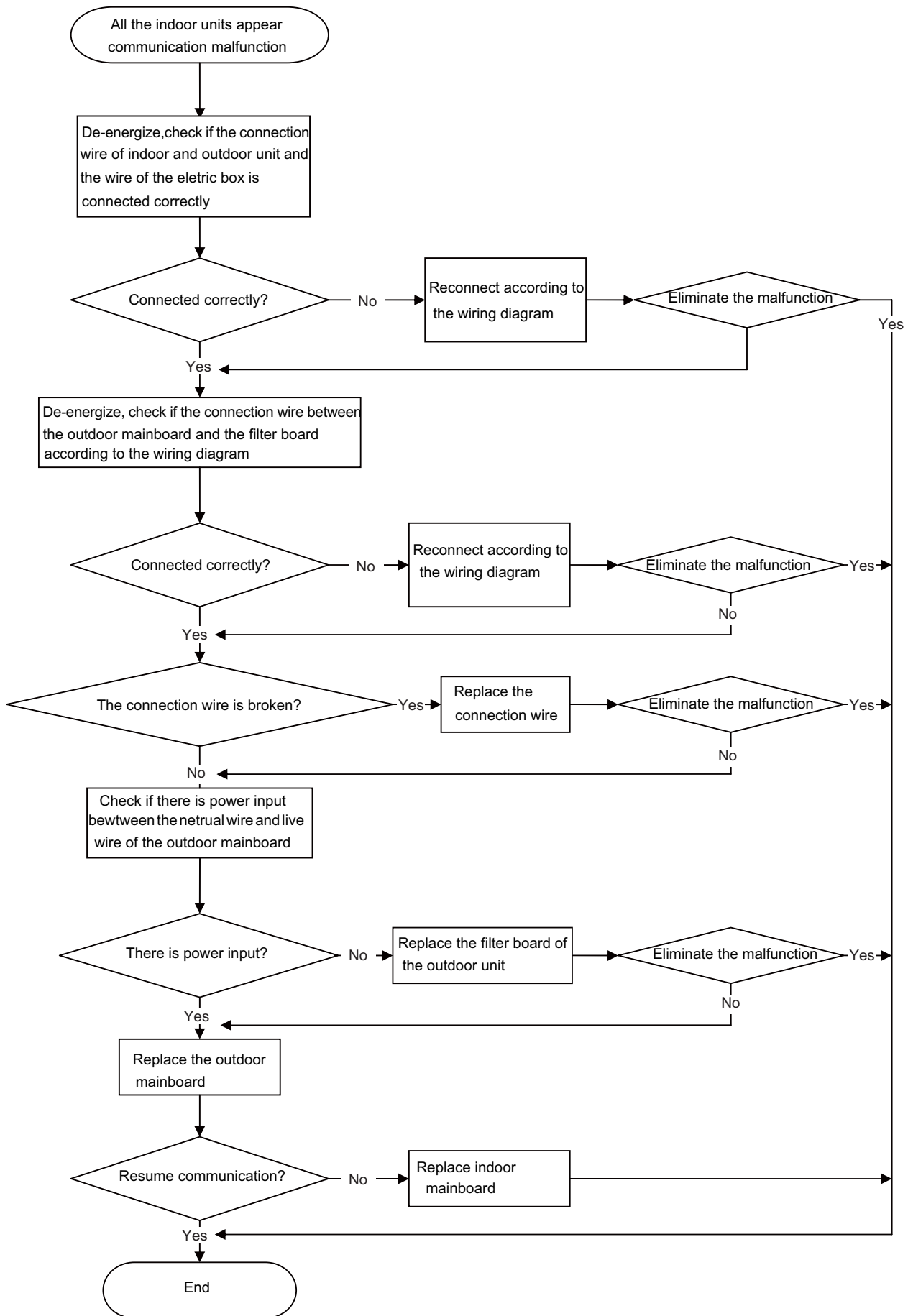

9. Anti-high temperature and overload malfunction

Main checking points:

- If the outdoor ambient temperature is within the normal range;
- If the indoor fan and outdoor fan are running normally;
- If the indoor and outdoor radiation environment is good;

Flow chart:

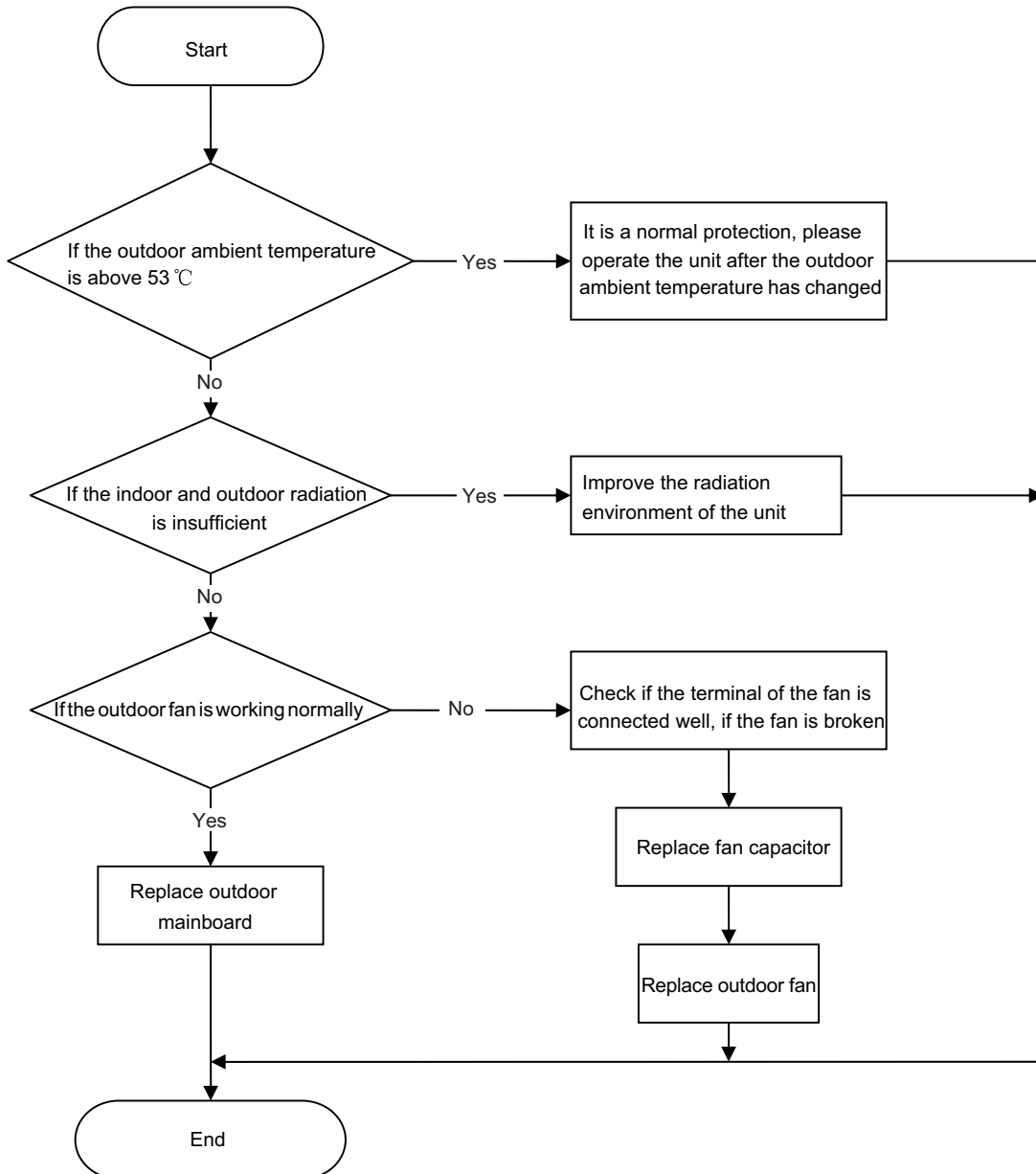

9.4 Maintenance Method for Normal Malfunction

1. Air Conditioner Can't be Started Up

Possible Causes	Discriminating Method (Air conditioner Status)	Troubleshooting
No power supply, or poor connection for power plug	After energization, operation indicator isn't bright and the buzzer can't give out sound	Confirm whether it's due to power failure. If yes, wait for power recovery. If not, check power supply circuit and make sure the power plug is connected well.
Wrong wire connection between indoor unit and outdoor unit, or poor connection for wiring terminals	Under normal power supply circumstances, operation indicator isn't bright after energization	Check the circuit according to circuit diagram and connect wires correctly. Make sure all wiring terminals are connected firmly
Electric leakage for air conditioner	After energization, room circuit breaker trips off at once	Make sure the air conditioner is grounded reliably Make sure wires of air conditioner is connected correctly Check the wiring inside air conditioner. Check whether the insulation layer of power cord is damaged; if yes, place the power cord.
Model selection for air switch is improper	After energization, air switch trips off	Select proper air switch
Malfunction of remote controller	After energization, operation indicator is bright, while no display on remote controller or buttons have no action.	Replace batteries for remote controller Repair or replace remote controller

2. Poor Cooling (Heating) for Air Conditioner

Possible Causes	Discriminating Method (Air conditioner Status)	Troubleshooting
Set temperature is improper	Observe the set temperature on remote controller	Adjust the set temperature
Rotation speed of the IDU fan motor is set too low	Small wind blow	Set the fan speed at high or medium
Filter of indoor unit is blocked	Check the filter to see it's blocked	Clean the filter
Installation position for indoor unit and outdoor unit is improper	Check whether the installation position is proper according to installation requirement for air conditioner	Adjust the installation position, and install the rainproof and sunproof for outdoor unit
Refrigerant is leaking	Discharged air temperature during cooling is higher than normal discharged wind temperature; Discharged air temperature during heating is lower than normal discharged wind temperature; Unit's pressure is much lower than regulated range	Find out the leakage causes and deal with it. Add refrigerant.
Malfunction of 4-way valve	Blow cold wind during heating	Replace the 4-way valve
Malfunction of capillary	Discharged air temperature during cooling is higher than normal discharged wind temperature; Discharged air temperature during heating is lower than normal discharged wind temperature; Unit's pressure is much lower than regulated range. If refrigerant isn't leaking, part of capillary is blocked	Replace the capillary
Flow volume of valve is insufficient	The pressure of valves is much lower than that stated in the specification	Open the valve completely
Malfunction of horizontal louver	Horizontal louver can't swing	Refer to point 3 of maintenance method for details
Malfunction of the IDU fan motor	The IDU fan motor can't operate	Refer to troubleshooting for H6 for maintenance method in details
Malfunction of the ODU fan motor	The ODU fan motor can't operate	Refer to point 4 of maintenance method for details
Malfunction of compressor	Compressor can't operate	Refer to point 5 of maintenance method for details

3. Horizontal Louver Can't Swing

Possible Causes	Discriminating Method (Air conditioner Status)	Troubleshooting
Wrong wire connection, or poor connection	Check the wiring status according to circuit diagram	Connect wires according to wiring diagram to make sure all wiring terminals are connected firmly
Stepping motor is damaged	Stepping motor can't operate	Repair or replace stepping motor
Main board is damaged	Others are all normal, while horizontal louver can't operate	Replace the main board with the same model

4. ODU Fan Motor Can't Operate

Possible causes	Discriminating method (air conditioner status)	Troubleshooting
Wrong wire connection, or poor connection	Check the wiring status according to circuit diagram	Connect wires according to wiring diagram to make sure all wiring terminals are connected firmly
Capacity of the ODU fan motor is damaged	Measure the capacity of fan capacitor with an universal meter and find that the capacity is out of the deviation range indicated on the nameplate of fan capacitor.	Replace the capacity of fan
Power voltage is a little low or high	Use universal meter to measure the power supply voltage. The voltage is a little high or low	Suggest to equip with voltage regulator
Motor of outdoor unit is damaged	When unit is on, cooling/heating performance is bad and ODU compressor generates a lot of noise and heat.	Change compressor oil and refrigerant. If no better, replace the compressor with a new one

5. Compressor Can't Operate

Possible causes	Discriminating method (air conditioner status)	Troubleshooting
Wrong wire connection, or poor connection	Check the wiring status according to circuit diagram	Connect wires according to wiring diagram to make sure all wiring terminals are connected firmly
Capacity of compressor is damaged	Measure the capacity of fan capacitor with an universal meter and find that the capacity is out of the deviation range indicated on the nameplate of fan capacitor.	Replace the compressor capacitor
Power voltage is a little low or high	Use universal meter to measure the power supply voltage. The voltage is a little high or low	Suggest to equip with voltage regulator
Coil of compressor is burnt out	Use universal meter to measure the resistance between compressor terminals and it's 0	Repair or replace compressor
Cylinder of compressor is blocked	Compressor can't operate	Repair or replace compressor

6. Air Conditioner is Leaking

Possible causes	Discriminating method (air conditioner status)	Troubleshooting
Drain pipe is blocked	Water leaking from indoor unit	Eliminate the foreign objects inside the drain pipe
Drain pipe is broken	Water leaking from drain pipe	Replace drain pipe
Wrapping is not tight	Water leaking from the pipe connection place of indoor unit	Wrap it again and bundle it tightly

7. Abnormal Sound and Vibration

Possible causes	Discriminating method (air conditioner status)	Troubleshooting
When turn on or turn off the unit, the panel and other parts will expand and there's abnormal sound	There's the sound of "PAPA"	Normal phenomenon. Abnormal sound will disappear after a few minutes.
When turn on or turn off the unit, there's abnormal sound due to flow of refrigerant inside air conditioner	Water-running sound can be heard	Normal phenomenon. Abnormal sound will disappear after a few minutes.
Foreign objects inside the indoor unit or there're parts touching together inside the indoor unit	There's abnormal sound fro indoor unit	Remove foreign objects. Adjust all parts' position of indoor unit, tighten screws and stick damping plaster between connected parts
Foreign objects inside the outdoor unit or there're parts touching together inside the outdoor unit	There's abnormal sound fro outdoor unit	Remove foreign objects. Adjust all parts' position of outdoor unit, tighten screws and stick damping plaster between connected parts
Short circuit inside the magnetic coil	During heating, the way valve has abnormal electromagnetic sound	Replace magnetic coil
Abnormal shake of compressor	Outdoor unit gives out abnormal sound	Adjust the support foot mat of compressor, tighten the bolts
Abnormal sound inside the compressor	Abnormal sound inside the compressor	If add too much refrigerant during maintenance, please reduce refrigerant properly. Replace compressor for other circumstances.

11. Removal Procedure



Warning: Be sure to wait for a minimum of 20 minutes after turning off all power supplies and discharge the refrigerant completely before removal.

MS-E14AIN

NOTE: only grille has some differences

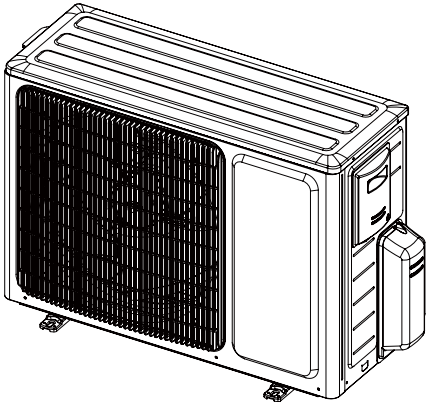
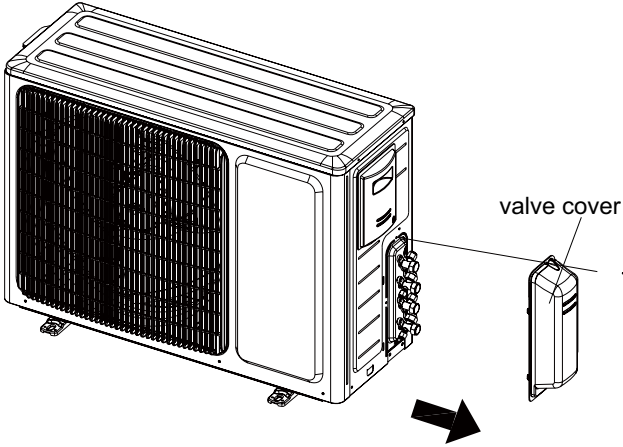
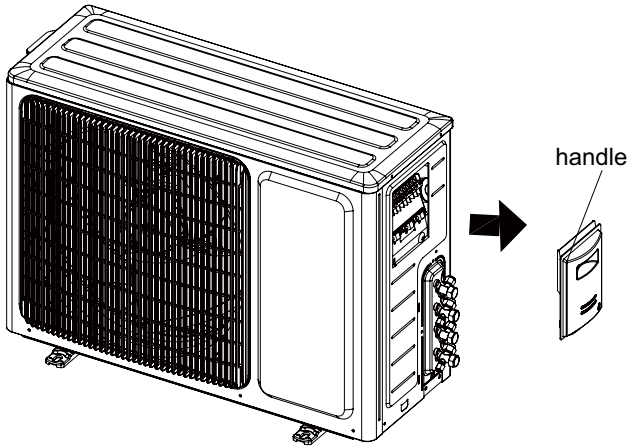
Steps	Procedure	
1. Before disassembly	Complete axonometric drawing.	
2. Remove valve cover	Remove the connection screw fixing the valve cover and then remove the valve cover.	
3. Remove handle	Remove the connection screw fixing the handle and the right side plate, and then remove the handle.	

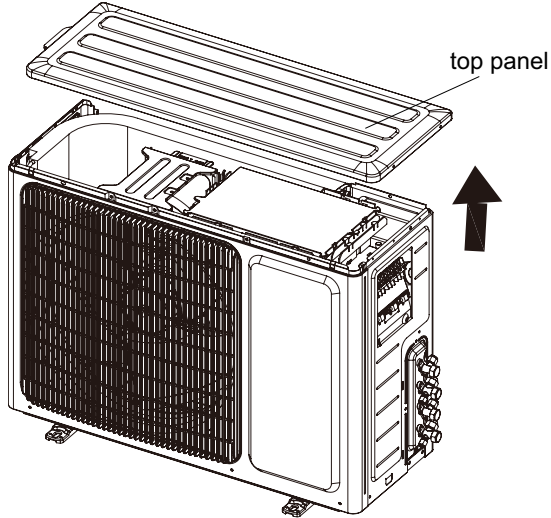
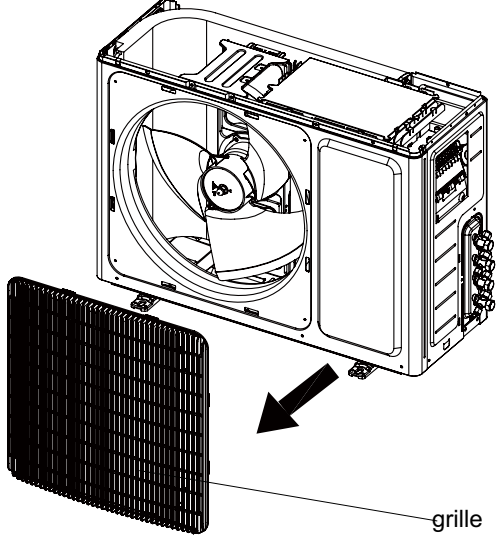
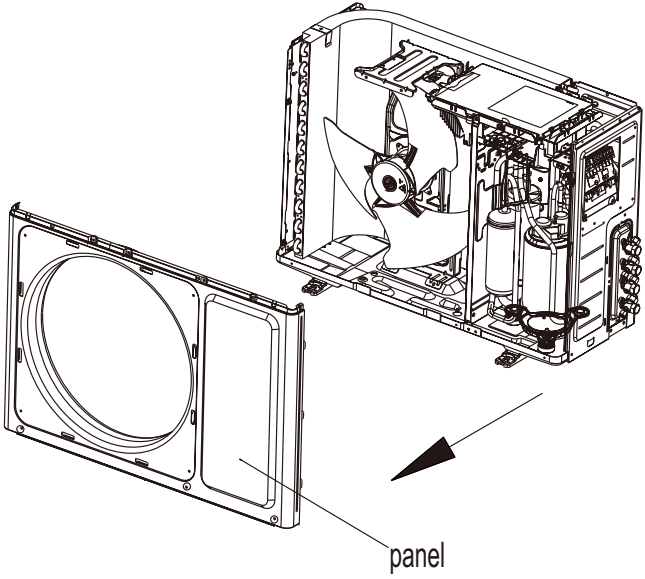
Steps	Procedure
4. Remove top panel	<p>Remove the connection screws connecting the top panel and the front panel, and then remove the top panel.</p> 
5. Remove front grille	<p>Remove the connection screws connecting the front grille and the front panel, and then loosen the clasp to remove the front grille.</p> 
6. Remove front panel	<p>Remove the screws connecting the front panel and then remove the front panel.</p> 

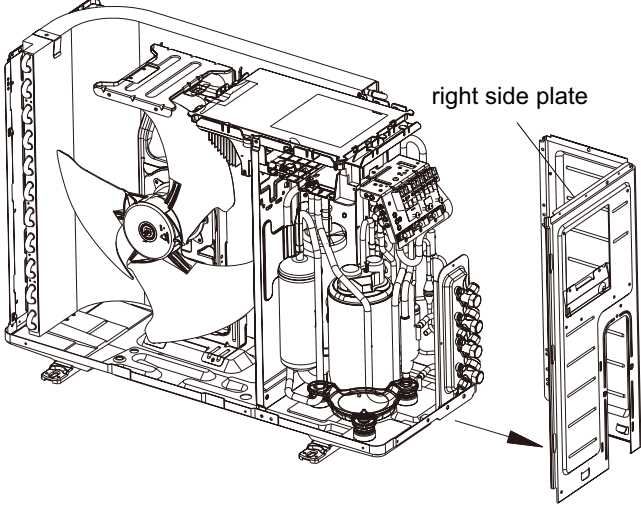
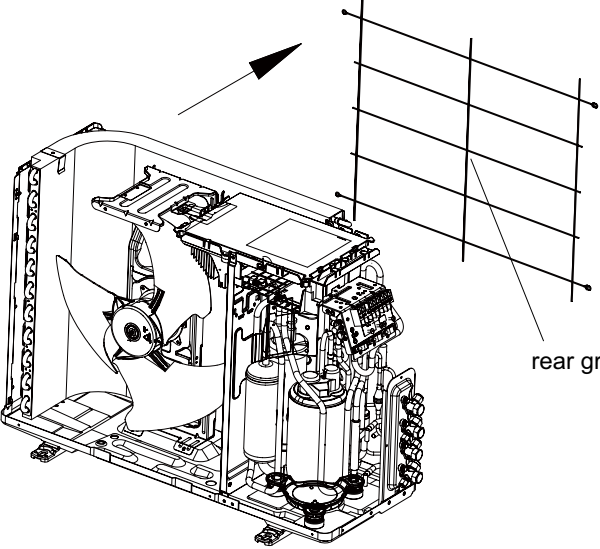
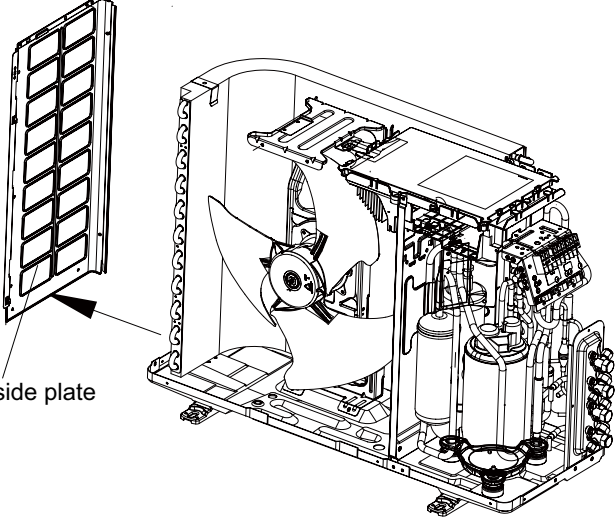
Steps	Procedure
7. Remove right side plate	<p data-bbox="240 454 750 563">Remove the screws connecting the right side plate with the chassis and the valve support. Then remove the right side plate.</p>  <p data-bbox="1320 351 1479 377">right side plate</p>
8. Remove rear grill	<p data-bbox="240 1000 750 1109">Remove the screws connecting the rear grill and left side plate, and then remove the rear grill.</p>  <p data-bbox="1417 1137 1511 1164">rear grill</p>
9. Remove left side plate	<p data-bbox="240 1574 750 1683">Remove the screws fixing the left side plate with the chassis and the condenser support, and then remove the left side plate.</p>  <p data-bbox="865 1782 1008 1808">left side plate</p>

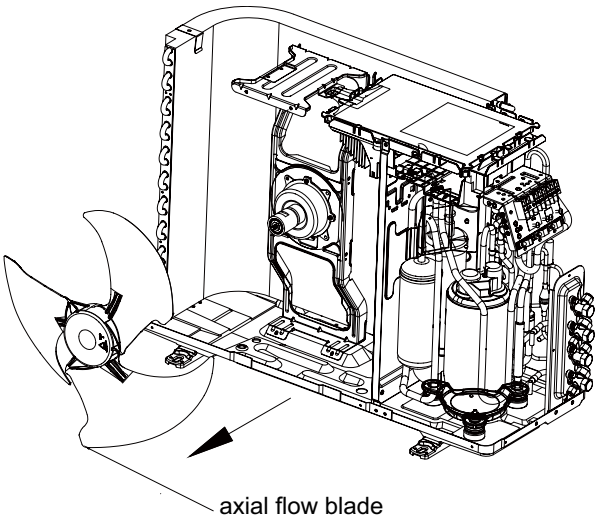
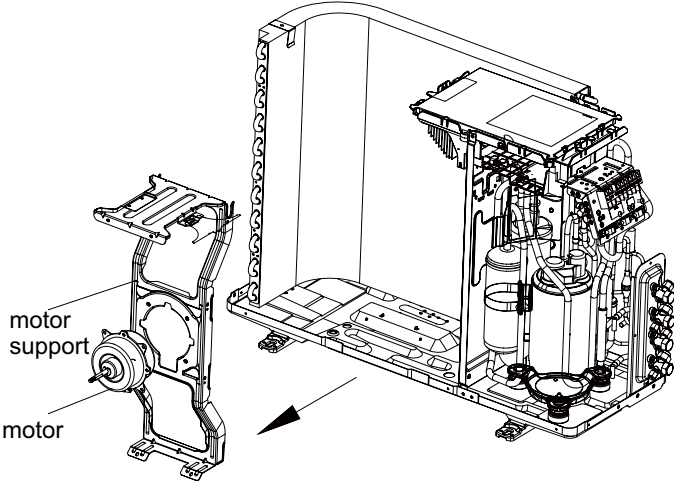
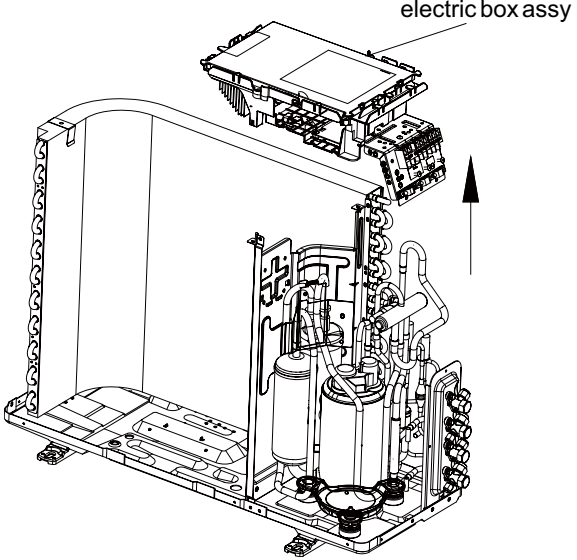
Steps	Procedure	
10. Remove axial flow blade	<p>Remove the nut on the blade and then remove the axial flow blade.</p>	 <p>The diagram shows a side view of the engine assembly with the axial flow blade being removed. An arrow points to the blade, which is labeled "axial flow blade".</p>
11. Remove motor and motor support	<p>Remove the 4 tapping screws fixing the motor and disconnect the leading wire insert of the motor. Then remove the motor. Remove the 2 tapping screws fixing the motor support and chassis, and then lift the motor support to remove it.</p>	 <p>The diagram shows the motor and motor support being removed from the engine assembly. Arrows point to the "motor support" and "motor" components.</p>
12. Remove electric box assy	<p>Remove the screws fixing the electric box assy and the middle isolation sheet, loosen the wire bundle, unplug the wiring terminals, and then lift the electric box assy to remove it.</p>	 <p>The diagram shows the electric box assembly being lifted from the engine assembly. An arrow points to the "electric box assy" component.</p>

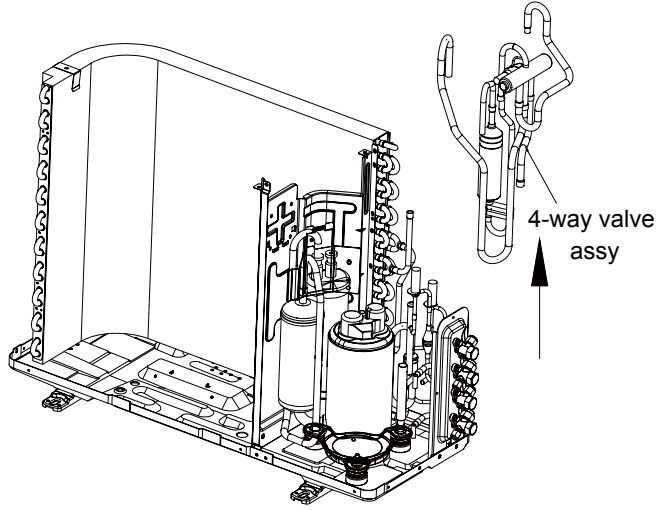
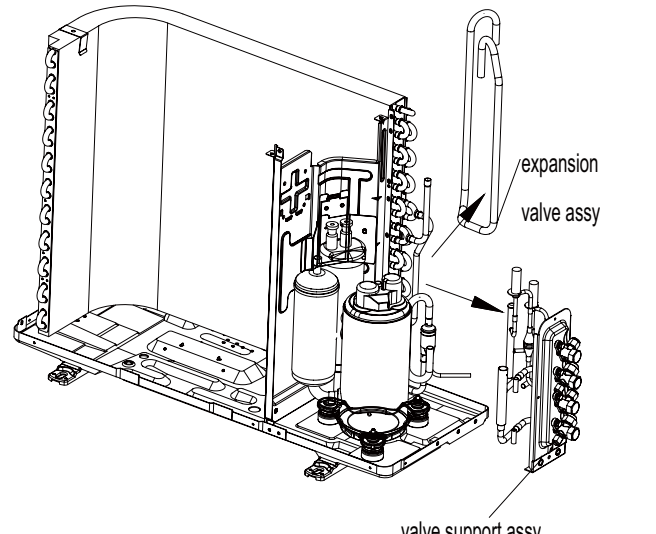
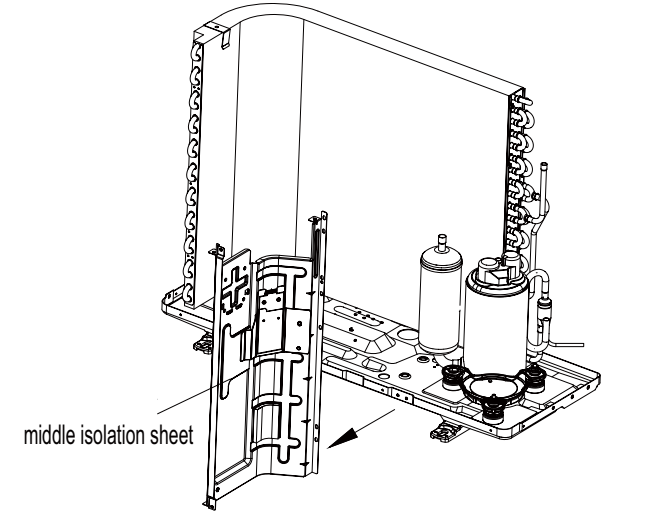
Steps	Procedure	
13. Remove 4-way valve assy	<p>Unsolder the welding joint connecting the 4-way valve assy with compressor suction and discharge port, the valve with the outlet pipe of condenser. Then lift the 4-way valve assy to remove it. (NOTE: Discharge the refrigerant completely before unsoldering.)</p>	 <p>4-way valve assy</p>
14. Remove valve support sub-assy and expansion valve assy	<p>Remove the screw connecting the valve support and the chassis, and then remove the valve support assy. Unsolder the welding joint connecting the electronic expansion valve assy with the cut-off valve and the condenser connection pipe, and then remove the expansion valve assy.</p>	 <p>expansion valve assy</p> <p>valve support assy</p>
15. Remove middle isolation sheet	<p>Remove the screws connecting the middle isolation sheet with the chassis assy and the condenser assy, and then remove the middle isolation sheet.</p>	 <p>middle isolation sheet</p>

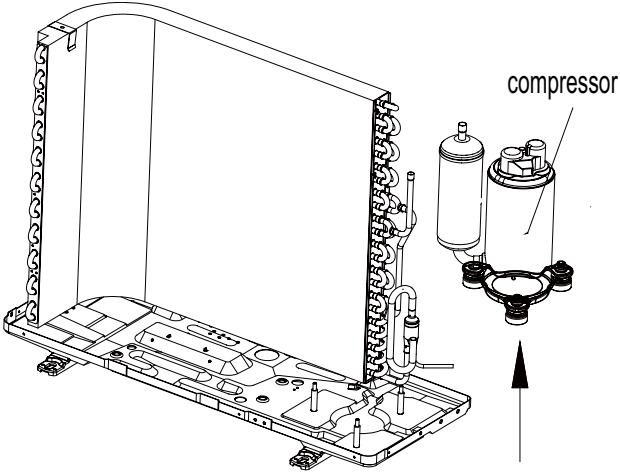
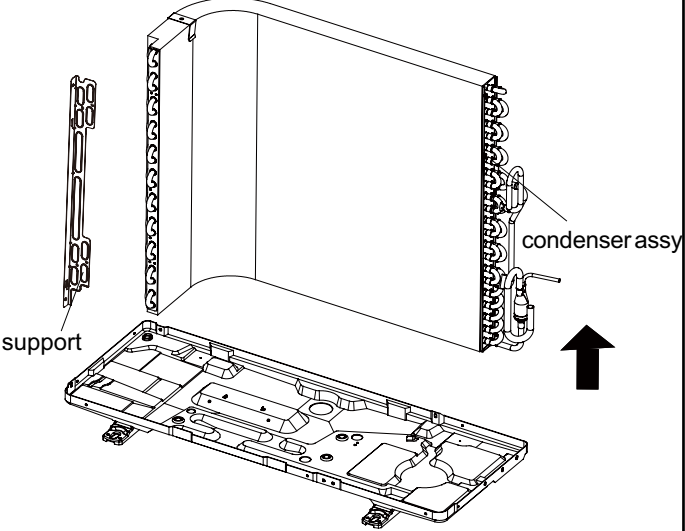
Steps	Procedure
16. Remove compressor	<p data-bbox="224 432 732 504">Remove the 3 foot nuts fixing the compressor and then remove the compressor.</p> 
17. Remove condenser assy	<p data-bbox="224 1057 732 1166">Remove the screws fixing the condenser support and then remove the condenser support.</p> <p data-bbox="224 1181 732 1290">Remove the screws connecting the condenser support and the chassis assy, and then remove the condenser assy.</p> 

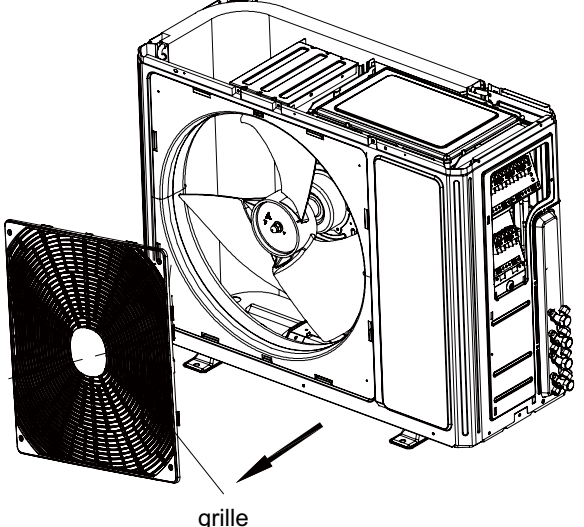
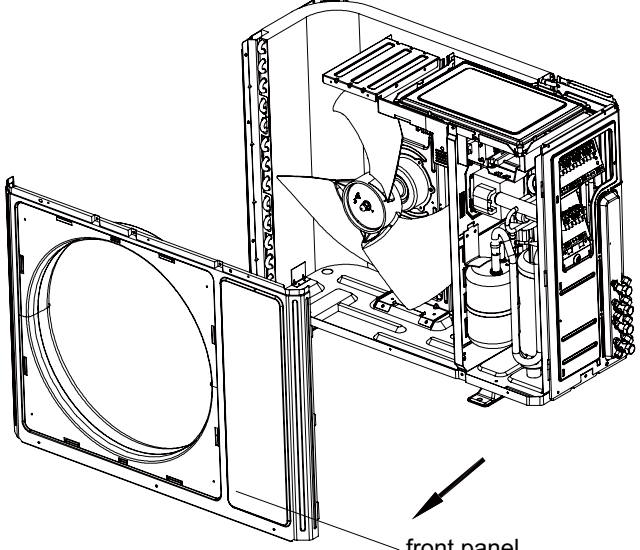
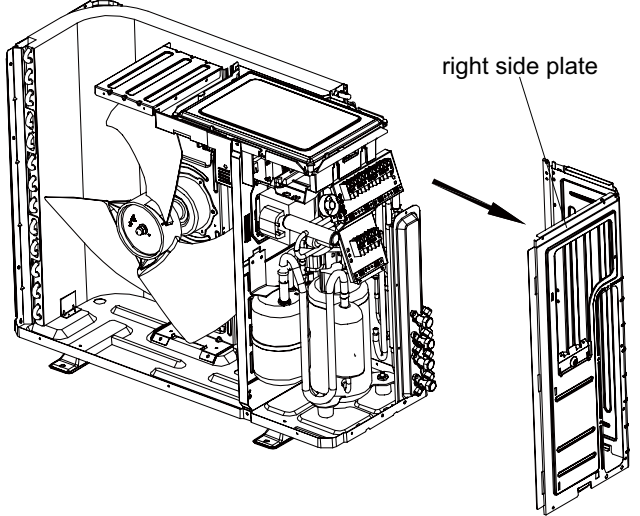
Steps	Procedure
4. Remove front grille	
	<p>Remove the connection screws connecting the front grille and the front panel, and then loosen the clasp to remove the front grille.</p>
 <p style="text-align: right;">grille</p>	
5. Remove front panel	
	<p>Remove the screws connecting the front panel and then remove the front panel.</p>
 <p style="text-align: right;">front panel</p>	
6. Remove right side plate	
	<p>Remove the screws connecting the right side plate with the chassis and the valve support. Then remove the right side plate.</p>
 <p style="text-align: right;">right side plate</p>	

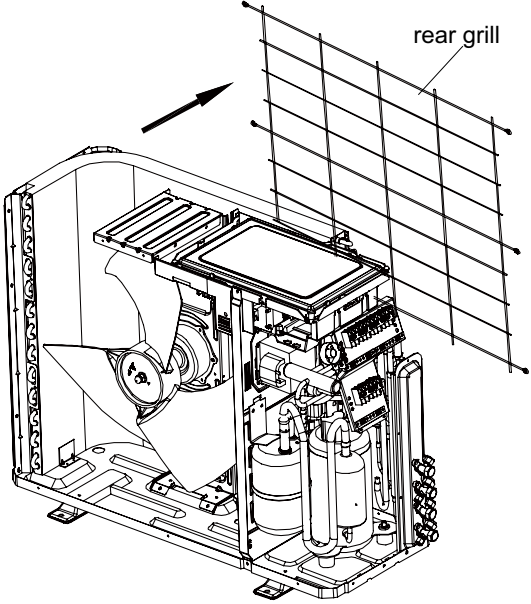
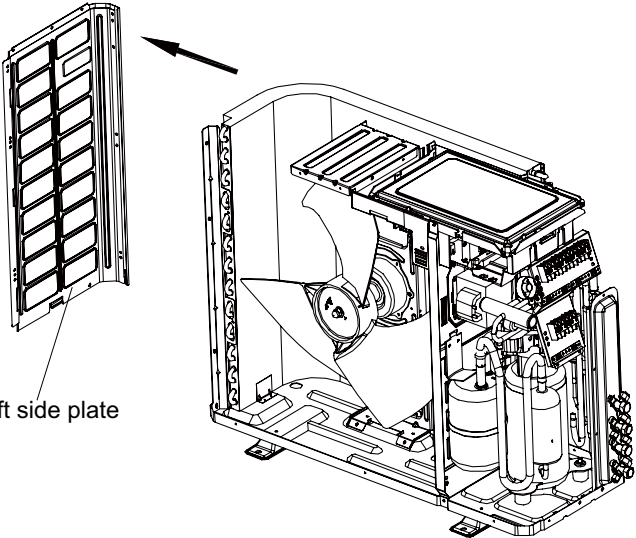
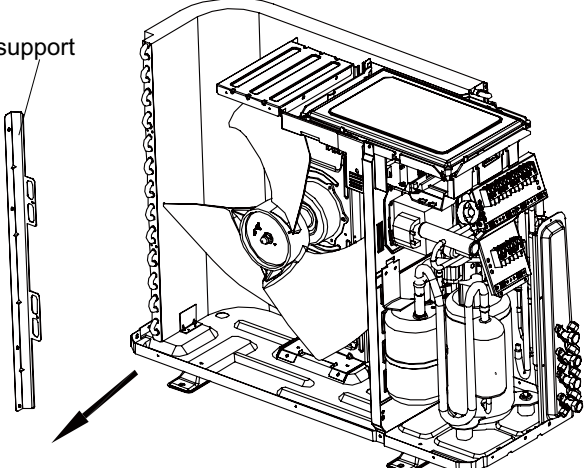
Steps	Procedure
7. Remove rear grill	<p data-bbox="224 504 748 559">Remove the screws connecting the rear grill and the left side plate, and then remove the rear grill.</p> 
8. Remove left side plate	<p data-bbox="224 1196 748 1284">Remove the screws fixing the left side plate with the chassis and the condenser support, and then remove the left side plate.</p> 
9. Remove condenser support	<p data-bbox="224 1742 727 1830">Remove the connection screws connecting the condenser support and the chassis, and then remove the condenser support.</p> 

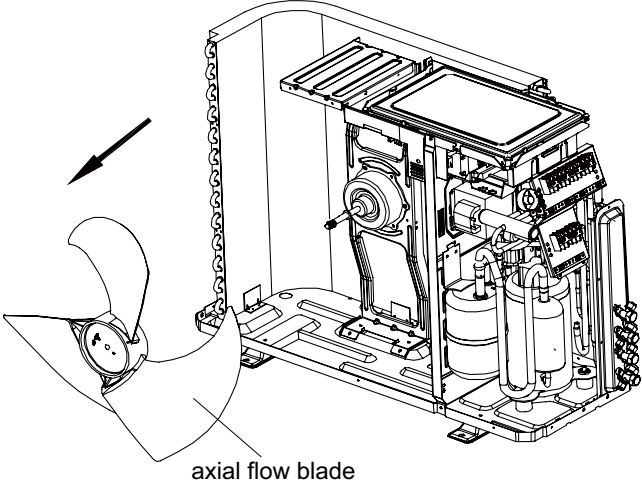
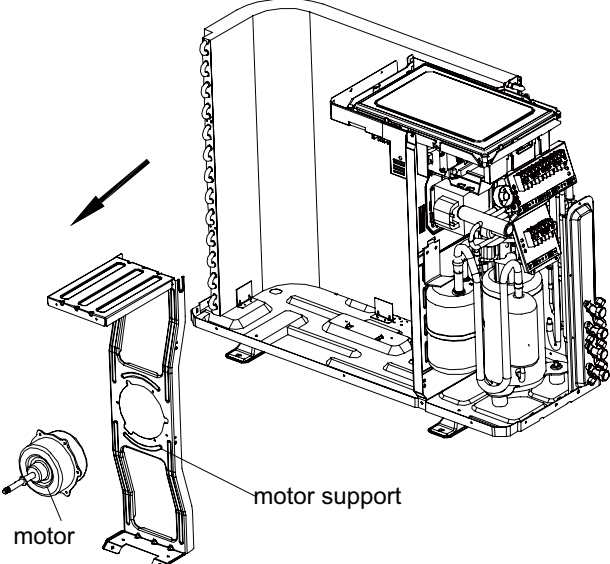
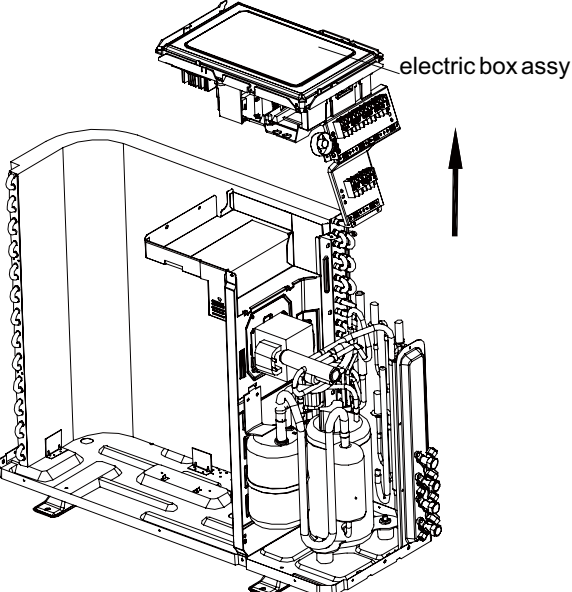
Steps	Procedure
10. Remove axial flow blade	<p data-bbox="235 526 776 580">Remove the nut on the blade and then remove the axial flow blade.</p>  <p data-bbox="1047 744 1214 770">axial flow blade</p>
11. Remove motor and motor support	<p data-bbox="235 1098 776 1240">Remove the 4 tapping screws fixing the motor and disconnect the leading wire insert of the motor. Then remove the motor. Remove the 2 tapping screws fixing the motor support and chassis, and then lift the motor support to remove it.</p>  <p data-bbox="885 1334 950 1360">motor</p> <p data-bbox="1128 1290 1279 1316">motor support</p>
12. Remove electric box assy	<p data-bbox="235 1742 787 1819">Remove the screws fixing the electric box assy and the middle isolation sheet, and then lift the electric box assy to remove it.</p>  <p data-bbox="1356 1465 1523 1491">electric box assy</p>

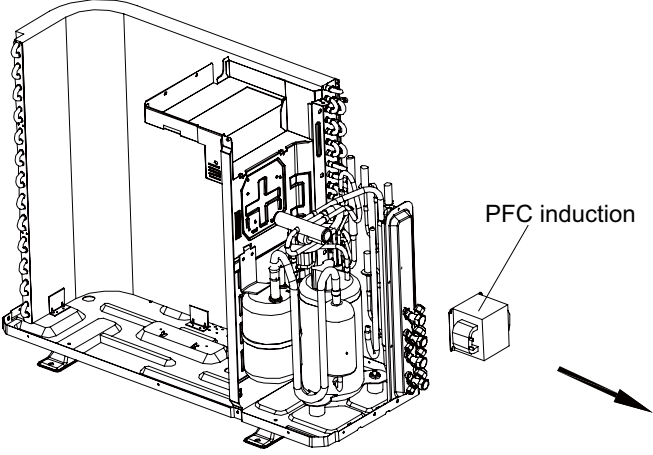
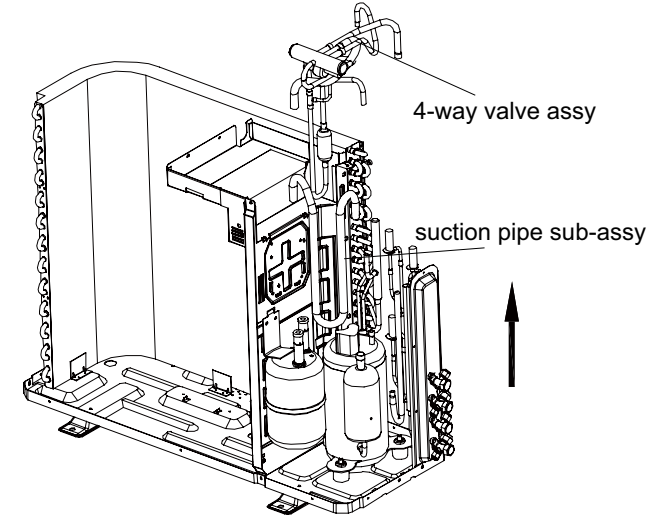
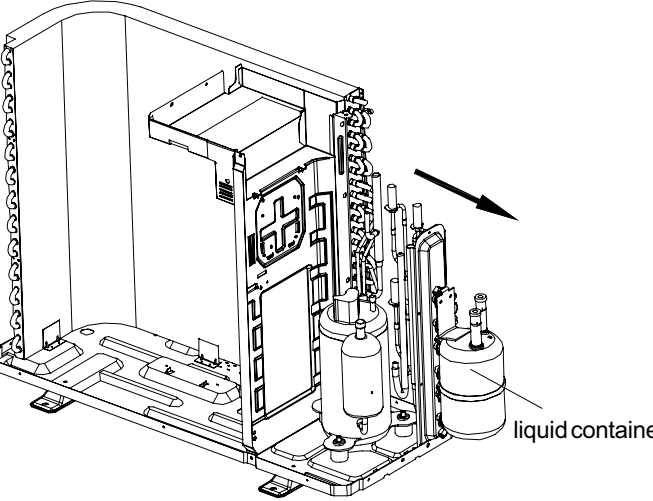
Steps	Procedure
13. Remove PFC induction	<p>Remove the screw connecting the PFC induction and middle isolation sheet, and then remove the PFC induction.</p>  <p>PFC induction</p>
14. Remove 4-way valve assy and suction pipe sub-assy	<p>Unsolder the welding joint connecting the 4-way valve assy with compressor suction and discharge port, the valve with the outlet pipe of condenser. Then lift the 4-way valve assy to remove it. (NOTE: Discharge the refrigerant completely before unsoldering.) Unsolder the welding joint connecting the suction pipe sub-assy with compressor and liquid container, and then remove the suction pipe sub-assy.</p>  <p>4-way valve assy</p> <p>suction pipe sub-assy</p>
15. Remove liquid container	<p>Remove the screws connecting the isolation plate sub-assy and the liquid container, and then lift the liquid container to remove it.</p>  <p>liquid container</p>

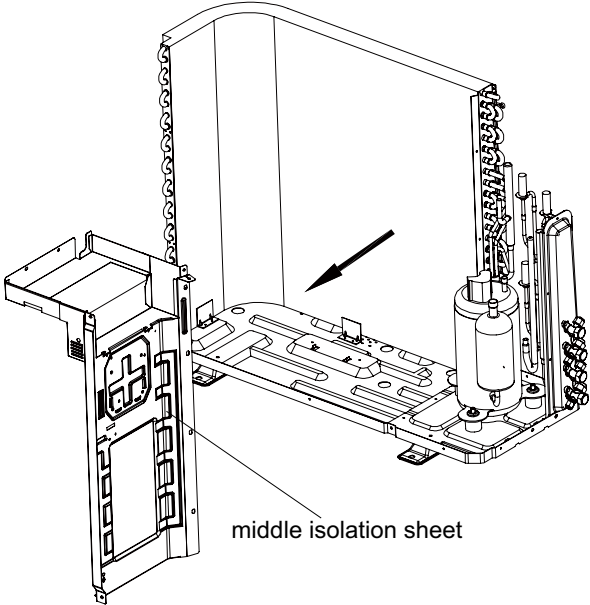
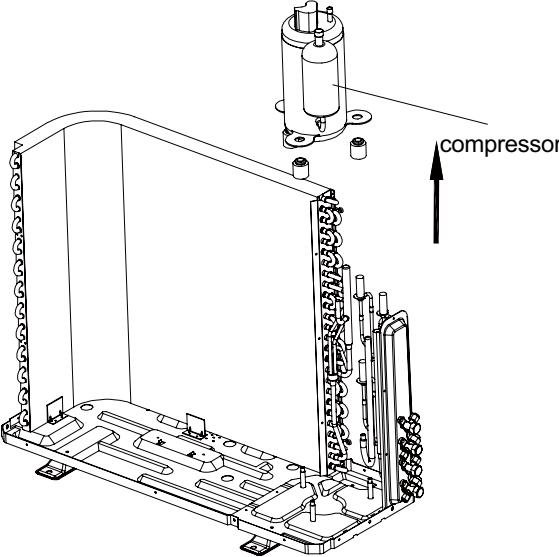
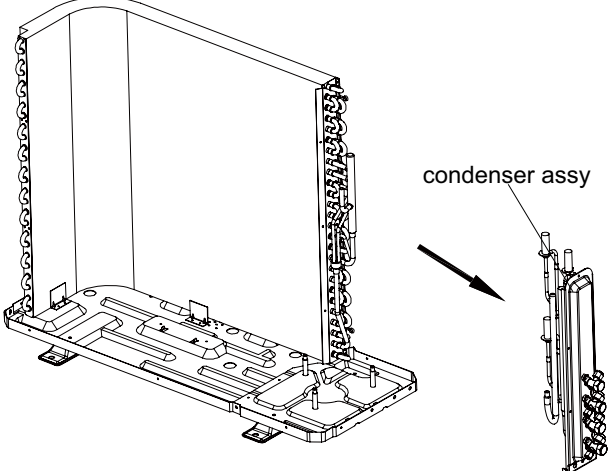
Steps	Procedure
16. Remove middle isolation sheet	<p data-bbox="232 467 797 552">Remove the screws connecting the middle isolation sheet with the chassis assy and the condenser assy, and then remove the middle isolation sheet.</p> 
17. Remove compressor	<p data-bbox="232 1159 768 1214">Remove the 3 foot nuts fixing the compressor and then remove the compressor.</p> 
18. Remove valve support sub-assy	<p data-bbox="232 1777 756 1862">Remove the screw connecting the valve support assy and the chassis sub-assy, and then remove the valve support assy.</p> 

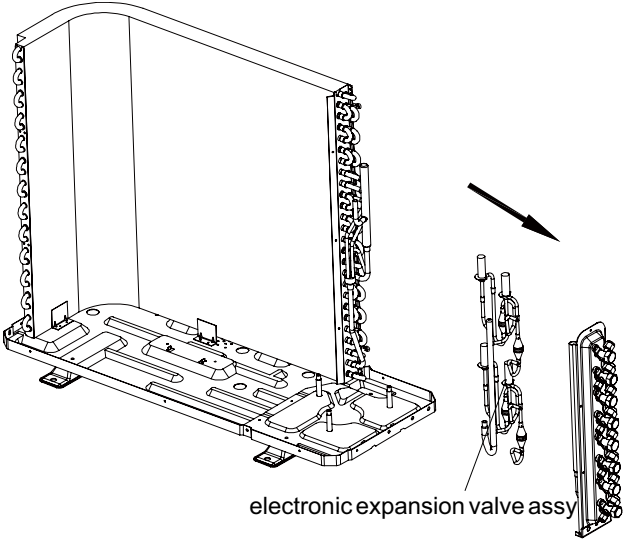
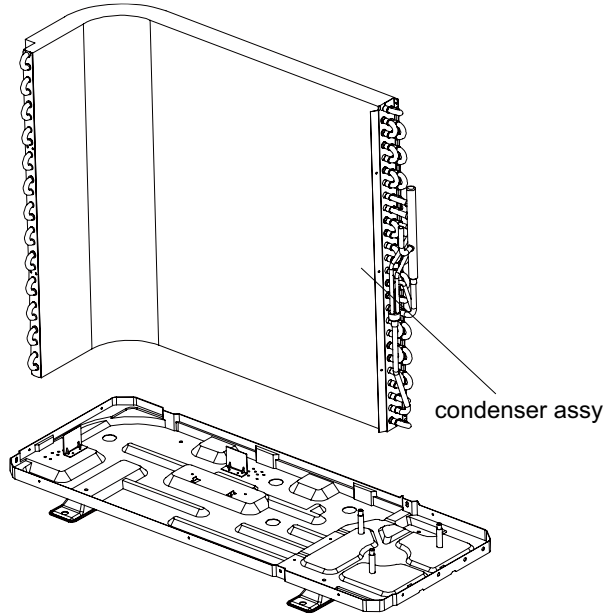
Steps	Procedure
<p>19. Remove electronic expansion valve assy</p>	<p>Unsolder the welding joint connecting the electronic expansion valve sub-assy with the gas collection pipe, and then remove the electronic expansion valve assy. (Note: when unsoldering, wrap the gas valve with a wet cloth completely to avoid damage to the valve caused by high temperature).</p>  <p>electronic expansion valve assy</p>
<p>20. Remove condenser assy</p>	<p>Remove the screws connecting the condenser assy and the chassis assy, and then remove the condenser assy.</p>  <p>condenser assy</p>

MS-E24AIN, MS-E28AIN

NOTE: Only cut-off valve of valve support, electronic expansion valve and coil have some differences

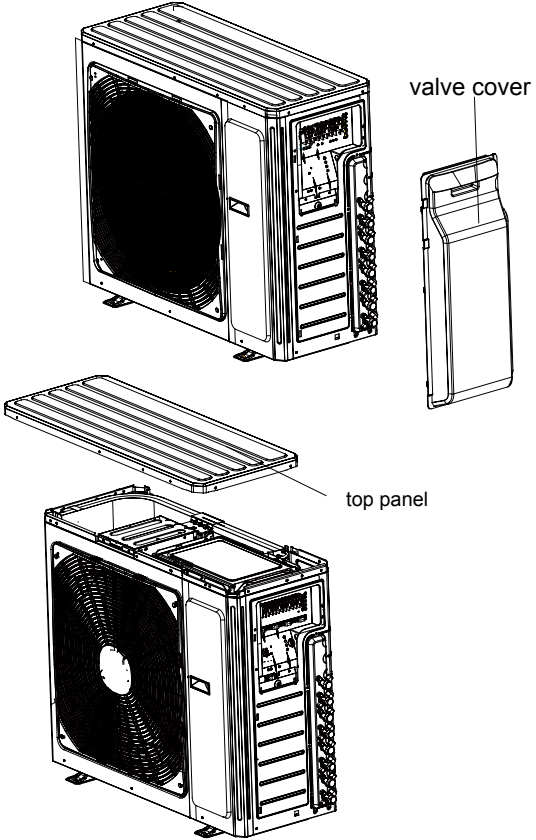
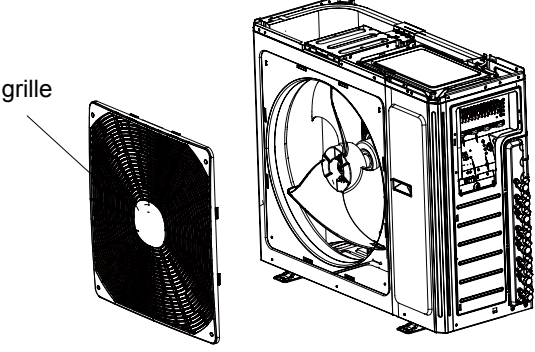
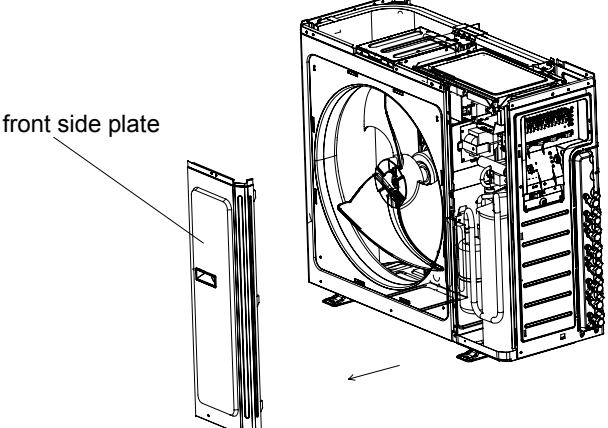
Steps	Procedure	
1. Remove valve cover and top panel		
1	Twist off the screws used for fixing and valve cover, pull valve cover up ward to remove it.	 <p>valve cover</p> <p>top panel</p>
2	Remove the 3 screws connecting the top panel with the front panel and the right side plate, and then remove the top panel.	
2. Remove grille, front side plate and panel.		
1	Remove the 2 screws connecting the grille and the panel, and then remove the grille.	 <p>grille</p>
2	Remove the 1 screw connecting the front side plate and the panel, and then remove the front side plate.	 <p>front side plate</p>

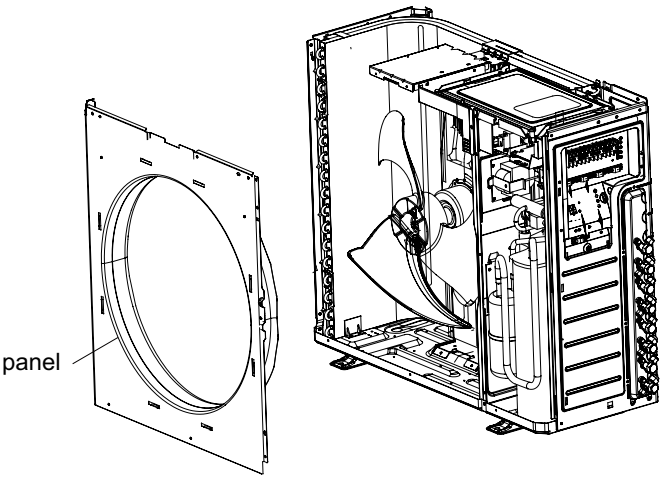
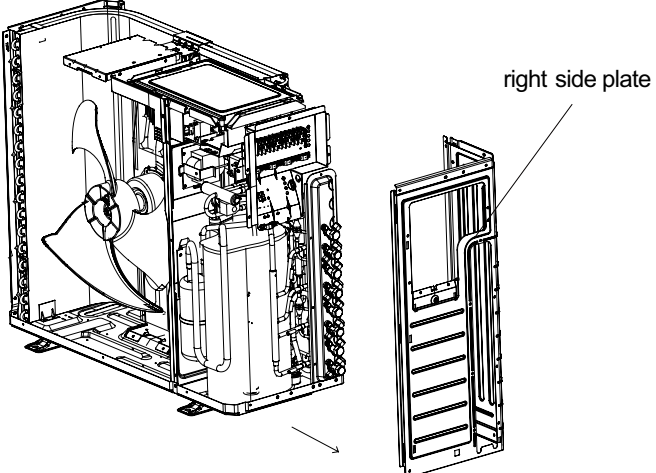
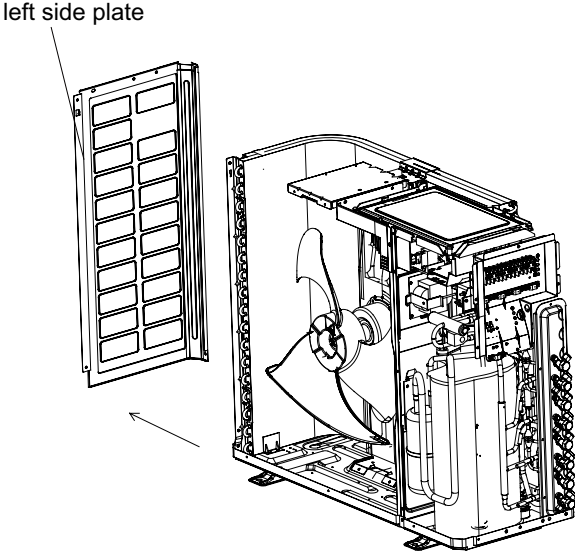
Steps	Procedure	
3	Remove the 5 screws connecting the panel with the chassis and the motor support, and then remove the panel.	 <p>panel</p>
3. Remove right side plate and left side plate		
1	Remove the screws connecting the right side plate with the chassis, the valve support and the electric box, and then remove the right side plate assy.	 <p>right side plate</p>
2	Remove the screws connecting the left side plate and the chassis, and then remove the left side plate assy.	 <p>left side plate</p>

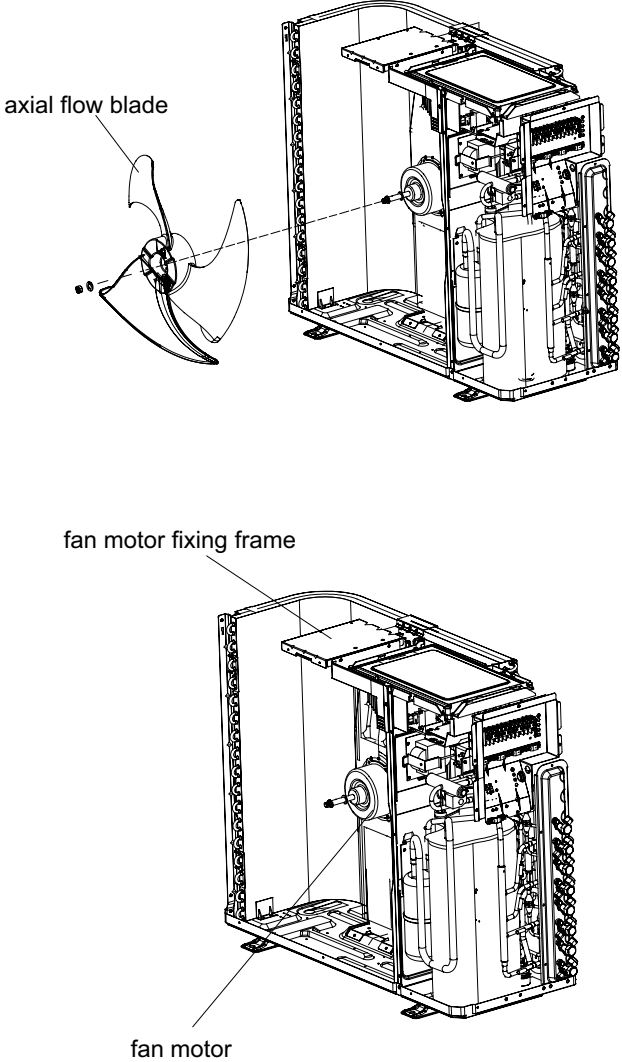
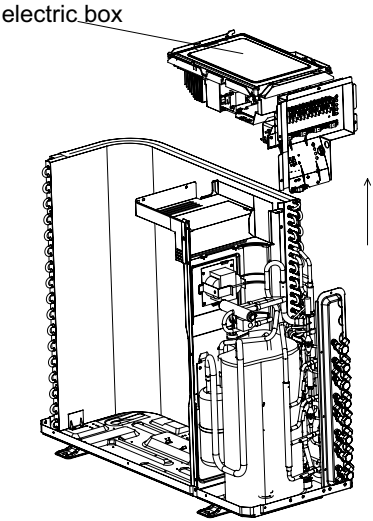
Steps	Procedure	
<p data-bbox="94 214 571 242">4. Remove fan motor and axial flow blade</p> <p data-bbox="120 417 134 445">1</p> <p data-bbox="224 401 691 467">Remove the nuts fixing the blade and then remove the axial flow blade.</p> <p data-bbox="125 1072 142 1100">2</p> <p data-bbox="217 1072 678 1306">Remove the 4 tapping screws fixing the motor; disconnect the leading wire insert of the motor and then remove the motor. Remove the 2 tapping screws fixing the motor support and then pull the motor support upwards to remove it.</p>		 <p data-bbox="846 395 1013 423">axial flow blade</p> <p data-bbox="906 825 1143 853">fan motor fixing frame</p> <p data-bbox="976 1334 1078 1362">fan motor</p>
<p data-bbox="94 1430 367 1458">5. Remove electric box</p>	<p data-bbox="217 1605 678 1758">Remove the screws fixing the electric box sub-assy; loosen the wire bundle; pull out the wiring terminals and then pull the electric box upwards to remove it.</p>	 <p data-bbox="1052 1443 1175 1472">electric box</p>

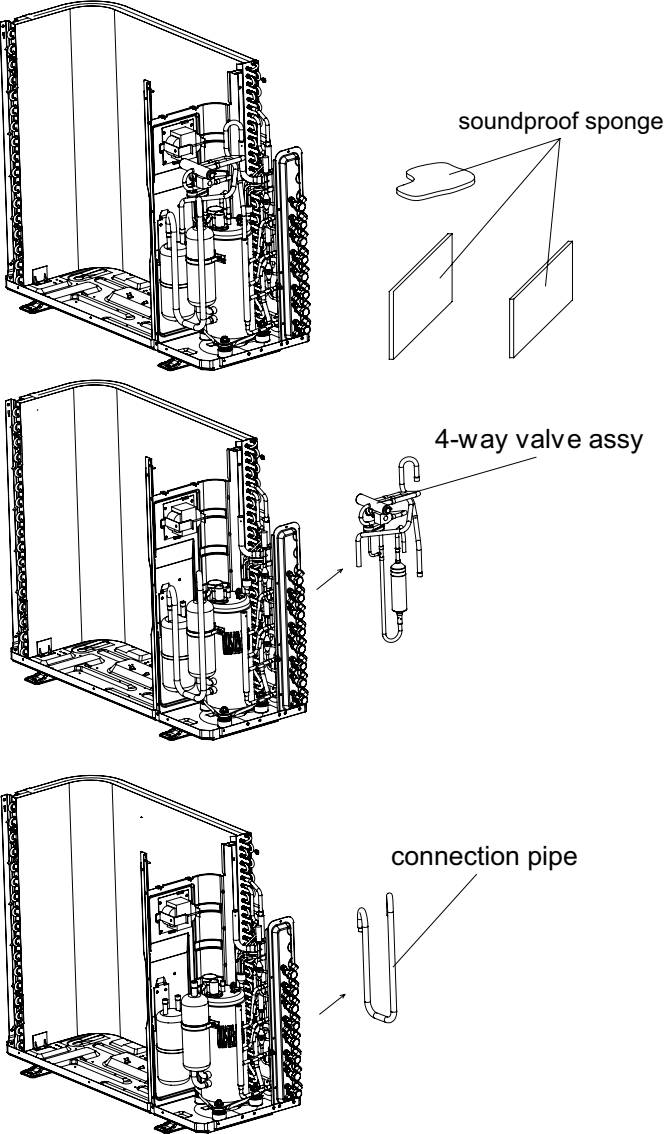
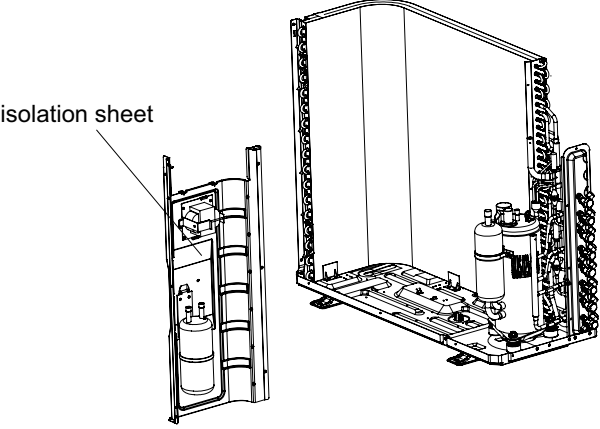
Steps	Procedure
<p data-bbox="115 242 716 275">6.Remove soundproof sponge and 4-way valve assy</p> <p data-bbox="142 384 776 428">1 Since the piping ports on the soundproof sponge are torn easily, remove the soundproof sponge carefully</p> <p data-bbox="142 880 727 995">2 Discharge the refrigerant completely;unsolder the pipelines connecting the compressor and the condenser assy,and then remove the 4-way valve assy.</p>	 <p>The diagrams illustrate the removal process in three stages:</p> <ul style="list-style-type: none"> Top diagram: Shows the soundproof sponge being removed from the unit. A callout labeled "soundproof sponge" points to the sponge and its corresponding cutouts in the cabinet panels. Middle diagram: Shows the 4-way valve assembly being removed. A callout labeled "4-way valve assy" points to the valve component. Bottom diagram: Shows a connection pipe being removed. A callout labeled "connection pipe" points to the U-shaped pipe.
<p data-bbox="115 1430 407 1463">7. Remove Isolation sheet</p>	<p data-bbox="212 1589 740 1644">Remove the 3 screws fixing the isolation sheet and then remove the Isolation sheet.</p>  <p>The diagram shows the isolation sheet being removed from the unit. A callout labeled "isolation sheet" points to the sheet and the screws that hold it in place.</p>

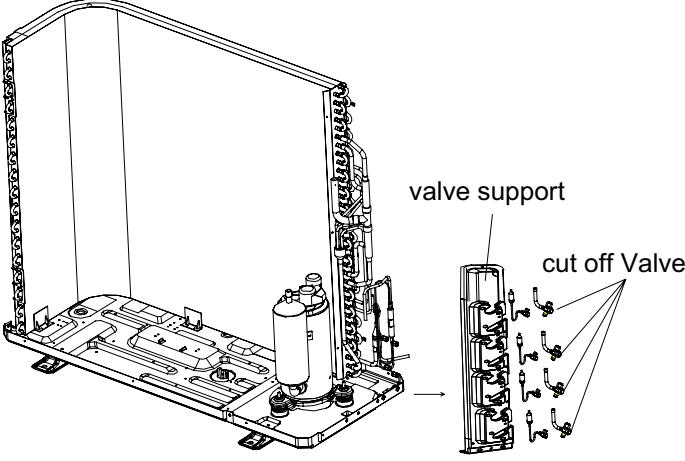
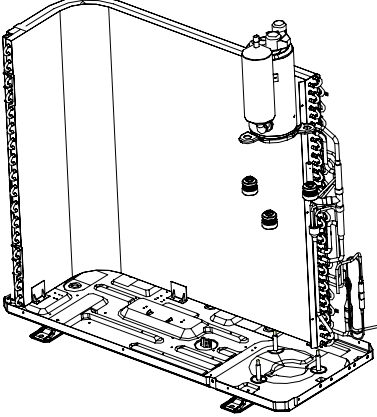
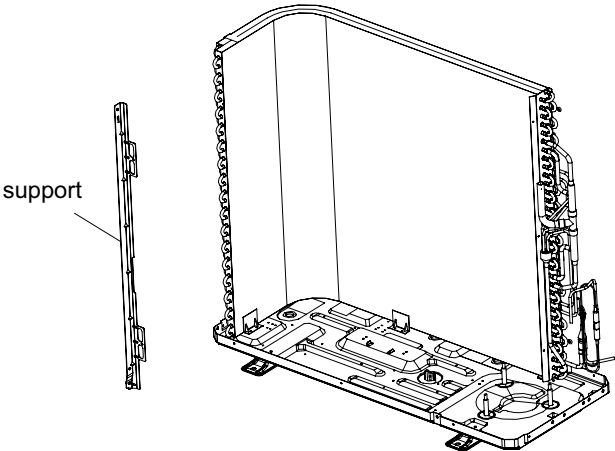
Steps	Procedure	
8. Remove Cut off Valve and Valve Support	<p>Remove the 2 bolts fixing the valve subassemblies. Unsolder the welding joint connecting the gas valve and the return air pipe. Remove the gas valve. (Note: When unsoldering the soldering joint, wrap the gas valve with wet cloth completely to avoid damage to the valve caused by high temperature.) Unsolder the welding joint connecting the liquid valve and the connecting pipe. Remove the liquid valve. Remove screws fixing valve support and then remove the valve support.</p>	 <p>The diagram illustrates the removal of the cut off valve and valve support. It shows a perspective view of the main assembly with a callout showing the valve support and cut off valve components. Labels include 'valve support' and 'cut off Valve'.</p>
9. Remove compressor	<p>Remove the 3 foot nuts fixing the compressor and then remove the compressor.</p>	 <p>The diagram shows the removal of the compressor. It depicts the main assembly with the compressor unit highlighted, indicating its position and the location of the foot nuts to be removed.</p>
10. Remove support	<p>1 Remove the screws connecting the support and condenser assy, and then remove the support.</p>	 <p>The diagram illustrates the removal of the support. It shows the main assembly with the support component highlighted. A label 'support' points to the component being removed.</p>

Steps	
11.Remove condenser sub-assy	
	<p data-bbox="212 467 704 532">Remove the chassis sub-assy and condenser sub-assy.</p>

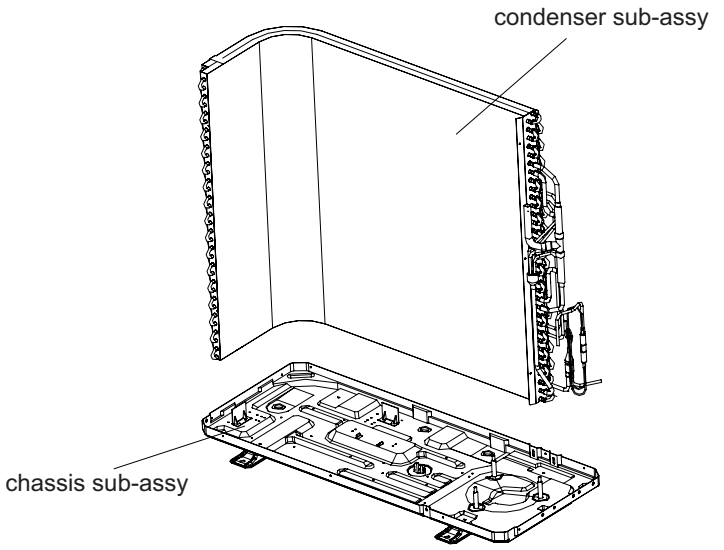

Appendix:

Appendix 1: Reference Sheet of Celsius and Fahrenheit

Conversion formula for Fahrenheit degree and Celsius degree: $T_f = T_c \times 1.8 + 32$

Set temperature

Fahrenheit display temperature (°F)	Fahrenheit (°F)	Celsius (°C)	Fahrenheit display temperature (°F)	Fahrenheit (°F)	Celsius (°C)	Fahrenheit display temperature (°F)	Fahrenheit (°F)	Celsius (°C)
61	60.8	16	69/70	69.8	21	78/79	78.8	26
62/63	62.6	17	71/72	71.6	22	80/81	80.6	27
64/65	64.4	18	73/74	73.4	23	82/83	82.4	28
66/67	66.2	19	75/76	75.2	24	84/85	84.2	29
68	68	20	77	77	25	86	86	30

Ambient temperature

Fahrenheit display temperature (°F)	Fahrenheit (°F)	Celsius (°C)	Fahrenheit display temperature (°F)	Fahrenheit (°F)	Celsius (°C)	Fahrenheit display temperature (°F)	Fahrenheit (°F)	Celsius (°C)
32/33	32	0	55/56	55.4	13	79/80	78.8	26
34/35	33.8	1	57/58	57.2	14	81	80.6	27
36	35.6	2	59/60	59	15	82/83	82.4	28
37/38	37.4	3	61/62	60.8	16	84/85	84.2	29
39/40	39.2	4	63	62.6	17	86/87	86	30
41/42	41	5	64/65	64.4	18	88/89	87.8	31
43/44	42.8	6	66/67	66.2	19	90	89.6	32
45	44.6	7	68/69	68	20	91/92	91.4	33
46/47	46.4	8	70/71	69.8	21	93/94	93.2	34
48/49	48.2	9	72	71.6	22	95/96	95	35
50/51	50	10	73/74	73.4	23	97/98	96.8	36
52/53	51.8	11	75/76	75.2	24	99	98.6	37
54	53.6	12	77/78	77	25			

Appendix 2: Configuration of Connection Pipe

1. Standard length of connection pipe

- 16.4ft, 24.6ft, 26.2ft.

2. Min. length of connection pipe is 9.84ft.

3. Max. length of connection pipe and max. high difference.

4. The additional refrigerant oil and refrigerant charging required after prolonging connection pipe

- After the length of connection pipe is prolonged for 32.8ft at the basis of standard length, you should add 5ml of refrigerant oil for each additional 16.4ft of connection pipe.

- The calculation method of additional refrigerant charging amount (on the basis of liquid pipe):

- When the length of connection pipe is above 16.4ft, add refrigerant according to the prolonged length of liquid pipe. The additional refrigerant charging amount per meter is different according to the diameter of liquid pipe. See the following sheet.

- Additional refrigerant charging amount = prolonged length of liquid pipe X additional refrigerant charging amount per meter

Cooling capacity	Max length of connection pipe	Max height difference
5000 Btu/h(1465 W)	49.2 ft	16.4 ft
7000 Btu/h(2051 W)	49.2 ft	16.4 ft
9000 Btu/h(2637 W)	49.2 ft	32.8 ft
12000 Btu/h(3516 W)	65.6 ft	32.8 ft
18000 Btu/h(5274 W)	82.0 ft	32.8 ft
24000 Btu/h(7032 W)	82.0 ft	32.8 ft
28000 Btu/h(8204 W)	98.4 ft	32.8 ft
36000 Btu/h(10548 W)	98.4 ft	65.6 ft
42000 Btu/h(12306 W)	98.4 ft	65.6 ft
48000 Btu/h(14064 W)	98.4 ft	65.6 ft

Additional refrigerant charging amount for R22, R407C, R410A and R134a			
Diameter of connection pipe		Outdoor unit throttle	
Liquid pipe(inch)	Gas pipe(inch)	Cooling only(oz/ft)	Cooling and heating(oz/ft)
Φ0.23	Φ0.37 or Φ0.47	0.53	0.71
Φ0.23 or Φ0.37	Φ0.63 or Φ0.75	0.53	0.71
Φ0.47	Φ0.75 or Φ0.84	1.06	4.23
Φ0.63	Φ1.0 or Φ1.25	2.12	4.23
Φ0.75	/	8.82	8.11
Φ0.84	/	12.34	12.34

Appendix 3: Pipe Expanding Method

⚠ Note:

Improper pipe expanding is the main cause of refrigerant leakage. Please expand the pipe according to the following steps:

A: Cut the pipe

- Confirm the pipe length according to the distance of indoor unit and outdoor unit.
- Cut the required pipe with pipe cutter.

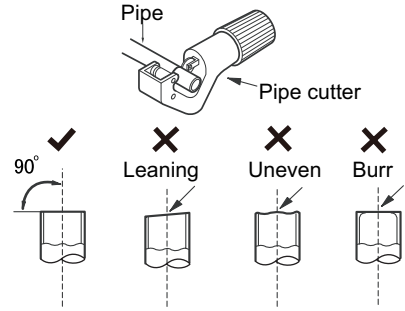

B: Remove the burrs

- Remove the burrs with shaper and prevent the burrs from getting into the pipe.

C: Put on suitable insulating pipe

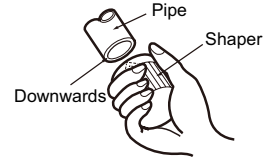

D: Put on the union nut

- Remove the union nut on the indoor connection pipe and outdoor valve; install the union nut on the pipe.

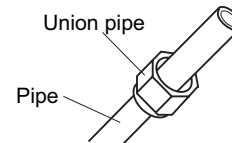

E: Expand the port

- Expand the port with expander.

⚠ Note:

- "A" is different according to the diameter, please refer to the sheet below:

Outer diameter(inch)	A(inch)	
	Max	Min
Φ0.23 - 0.25 (1/4")	0.051	0.028
Φ9.52 (3/8")	0.063	0.039
Φ0.37 - 0.5 (1/2")	0.071	0.039
Φ0.63 (5/8")	0.095	0.087

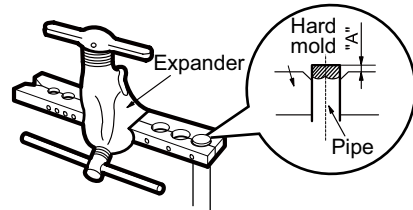

F: Inspection

- Check the quality of expanding port. If there is any blemish, expand the port again according to the steps above.

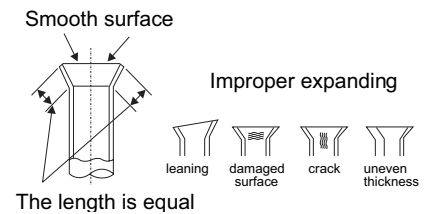

Appendix 4: List of Resistance for Temperature Sensor

Resistance Table of Ambient Temperature Sensor for Indoor and Outdoor Units(15K)

Temp(°C)	Resistance(kΩ)	Temp(°C)	Resistance(kΩ)	Temp(°C)	Resistance(kΩ)	Temp(°C)	Resistance(kΩ)
-19	138.1	20	18.75	59	3.848	98	1.071
-18	128.6	21	17.93	60	3.711	99	1.039
-17	121.6	22	17.14	61	3.579	100	1.009
-16	115	23	16.39	62	3.454	101	0.98
-15	108.7	24	15.68	63	3.333	102	0.952
-14	102.9	25	15	64	3.217	103	0.925
-13	97.4	26	14.36	65	3.105	104	0.898
-12	92.22	27	13.74	66	2.998	105	0.873
-11	87.35	28	13.16	67	2.896	106	0.848
-10	82.75	29	12.6	68	2.797	107	0.825
-9	78.43	30	12.07	69	2.702	108	0.802
-8	74.35	31	11.57	70	2.611	109	0.779
-7	70.5	32	11.09	71	2.523	110	0.758
-6	66.88	33	10.63	72	2.439	111	0.737
-5	63.46	34	10.2	73	2.358	112	0.717
-4	60.23	35	9.779	74	2.28	113	0.697
-3	57.18	36	9.382	75	2.206	114	0.678
-2	54.31	37	9.003	76	2.133	115	0.66
-1	51.59	38	8.642	77	2.064	116	0.642
0	49.02	39	8.297	78	1.997	117	0.625
1	46.6	40	7.967	79	1.933	118	0.608
2	44.31	41	7.653	80	1.871	119	0.592
3	42.14	42	7.352	81	1.811	120	0.577
4	40.09	43	7.065	82	1.754	121	0.561
5	38.15	44	6.791	83	1.699	122	0.547
6	36.32	45	6.529	84	1.645	123	0.532
7	34.58	46	6.278	85	1.594	124	0.519
8	32.94	47	6.038	86	1.544	125	0.505
9	31.38	48	5.809	87	1.497	126	0.492
10	29.9	49	5.589	88	1.451	127	0.48
11	28.51	50	5.379	89	1.408	128	0.467
12	27.18	51	5.197	90	1.363	129	0.456
13	25.92	52	4.986	91	1.322	130	0.444
14	24.73	53	4.802	92	1.282	131	0.433
15	23.6	54	4.625	93	1.244	132	0.422
16	22.53	55	4.456	94	1.207	133	0.412
17	21.51	56	4.294	95	1.171	134	0.401
18	20.54	57	4.139	96	1.136	135	0.391
19	19.63	58	3.99	97	1.103	136	0.382

Resistance Table of Tube Temperature Sensors for Indoor and Outdoor (20K)

Temp(°C)	Resistance(kΩ)	Temp(°C)	Resistance(kΩ)	Temp(°C)	Resistance(kΩ)	Temp(°C)	Resistance(kΩ)
-19	181.4	20	25.01	59	5.13	98	1.427
-18	171.4	21	23.9	60	4.948	99	1.386
-17	162.1	22	22.85	61	4.773	100	1.346
-16	153.3	23	21.85	62	4.605	101	1.307
-15	145	24	20.9	63	4.443	102	1.269
-14	137.2	25	20	64	4.289	103	1.233
-13	129.9	26	19.14	65	4.14	104	1.198
-12	123	27	18.13	66	3.998	105	1.164
-11	116.5	28	17.55	67	3.861	106	1.131
-10	110.3	29	16.8	68	3.729	107	1.099
-9	104.6	30	16.1	69	3.603	108	1.069
-8	99.13	31	15.43	70	3.481	109	1.039
-7	94	32	14.79	71	3.364	110	1.01
-6	89.17	33	14.18	72	3.252	111	0.983
-5	84.61	34	13.59	73	3.144	112	0.956
-4	80.31	35	13.04	74	3.04	113	0.93
-3	76.24	36	12.51	75	2.94	114	0.904
-2	72.41	37	12	76	2.844	115	0.88
-1	68.79	38	11.52	77	2.752	116	0.856
0	65.37	39	11.06	78	2.663	117	0.833
1	62.13	40	10.62	79	2.577	118	0.811
2	59.08	41	10.2	80	2.495	119	0.77
3	56.19	42	9.803	81	2.415	120	0.769
4	53.46	43	9.42	82	2.339	121	0.746
5	50.87	44	9.054	83	2.265	122	0.729
6	48.42	45	8.705	84	2.194	123	0.71
7	46.11	46	8.37	85	2.125	124	0.692
8	43.92	47	8.051	86	2.059	125	0.674
9	41.84	48	7.745	87	1.996	126	0.658
10	39.87	49	7.453	88	1.934	127	0.64
11	38.01	50	7.173	89	1.875	128	0.623
12	36.24	51	6.905	90	1.818	129	0.607
13	34.57	52	6.648	91	1.736	130	0.592
14	32.98	53	6.403	92	1.71	131	0.577
15	31.47	54	6.167	93	1.658	132	0.563
16	30.04	55	5.942	94	1.609	133	0.549
17	28.68	56	5.726	95	1.561	134	0.535
18	27.39	57	5.519	96	1.515	135	0.521
19	26.17	58	5.32	97	1.47	136	0.509

Resistance Table of Discharge Temperature Sensor for Outdoor(50K)

Temp(°C)	Resistance(kΩ)	Temp(°C)	Resistance(kΩ)	Temp(°C)	Resistance(kΩ)	Temp(°C)	Resistance(kΩ)
-29	853.5	10	98	49	18.34	88	4.75
-28	799.8	11	93.42	50	17.65	89	4.61
-27	750	12	89.07	51	16.99	90	4.47
-26	703.8	13	84.95	52	16.36	91	4.33
-25	660.8	14	81.05	53	15.75	92	4.20
-24	620.8	15	77.35	54	15.17	93	4.08
-23	580.6	16	73.83	55	14.62	94	3.96
-22	548.9	17	70.5	56	14.09	95	3.84
-21	516.6	18	67.34	57	13.58	96	3.73
-20	486.5	19	64.33	58	13.09	97	3.62
-19	458.3	20	61.48	59	12.62	98	3.51
-18	432	21	58.77	60	12.17	99	3.41
-17	407.4	22	56.19	61	11.74	100	3.32
-16	384.5	23	53.74	62	11.32	101	3.22
-15	362.9	24	51.41	63	10.93	102	3.13
-14	342.8	25	49.19	64	10.54	103	3.04
-13	323.9	26	47.08	65	10.18	104	2.96
-12	306.2	27	45.07	66	9.83	105	2.87
-11	289.6	28	43.16	67	9.49	106	2.79
-10	274	29	41.34	68	9.17	107	2.72
-9	259.3	30	39.61	69	8.85	108	2.64
-8	245.6	31	37.96	70	8.56	109	2.57
-7	232.6	32	36.38	71	8.27	110	2.50
-6	220.5	33	34.88	72	7.99	111	2.43
-5	209	34	33.45	73	7.73	112	2.37
-4	198.3	35	32.09	74	7.47	113	2.30
-3	199.1	36	30.79	75	7.22	114	2.24
-2	178.5	37	29.54	76	7.00	115	2.18
-1	169.5	38	28.36	77	6.76	116	2.12
0	161	39	27.23	78	6.54	117	2.07
1	153	40	26.15	79	6.33	118	2.02
2	145.4	41	25.11	80	6.13	119	1.96
3	138.3	42	24.13	81	5.93	120	1.91
4	131.5	43	23.19	82	5.75	121	1.86
5	125.1	44	22.29	83	5.57	122	1.82
6	119.1	45	21.43	84	5.39	123	1.77
7	113.4	46	20.6	85	5.22	124	1.73
8	108	47	19.81	86	5.06	125	1.68
9	102.8	48	19.06	87	4.90	126	1.64

PARTS GUIDE

NEW MULTI SYSTEM SERIES

**MS-E14AIN, MS-E18AIN, MS-E21AIN,
MS-E24AIN, MS-E28AIN**



NO.	Description	Part Code	Qty
		MS-E14AIN	
1	Front Grill	22413046	1
2	Cabinet	01433034P	1
3	Chassis Sub-assy	01700000013P	1
4	Gas-liquid Separator	07223048	1
5	Drainage Joint	26113009	1
6	Compressor Gasket	76710247	3
7	Compressor and fittings	00105249G	1
8	Magnet Coil	4300040045	1
9	4-way Valve Assy	03015200041	1
10	Temperature Sensor	39000073	1
11	Temperature Sensor	3900007301	1
12	Cut off Valve	07130239	1
13	Cut off Valve	071302391	1
14	Valve cover	22242101	1
15	Big Handle	26233048	1
16	Electric expand valve fitting	43000084	1
17	Electric expand valve fitting	4300008401	1
18	Clapboard Sub-Assy	01233206	1
19	Temperature Sensor	3900030901	1
20	Rear Grill	01473060	1
21	Condenser Assy	01124309	1
22	Coping	01253034P	1
23	Motor Support Sub-Assy	01703238	1
24	Left Side Plate	01303169P	1
25	Electric Box Assy	10000201928	1
26	Connecting Cable	4002050421	0
27	Fan Motor	1501308507	1
28	Axial Flow Fan	10333022	1

Above data is subject to change without notice.

NO.	Description	Part Code	Qty
		MS-E18AIN	
1	Front Grill	22413045	1
2	Front Panel	01535013P	1
3	Chassis Sub-assy	02803263P	1
4	Drainage Connector	06123401	1
5	Drainage hole Cap	06813401	1
6	Gas-liquid Separator Assy	07225017	1
7	Compressor and fittings	00105249G	1
8	Electrical Heater	7651300403	1
9	Magnet Coil	4300040045	1
10	4-Way Valve Assy	03073156	1
11	Right Side Plate	01303268P	1
12	Valve Support Assy	07133845	1
13	Electronic Expansion Valve assy	07133846	1
14	Valve Support Sub-Assy	0171312802P	1
15	Cut off Valve	07130239	1
16	Cut off Valve	071302391	1
17	Valve Cover	20123029	1
18	Electric Expand Valve Fitting	43000084	1
19	Electric Expand Valve Fitting	4300008401	1
20	Temperature Sensor	39000073	1
21	Temperature Sensor	3900007301	1
22	Wiring Clamp	26115004	1
23	Temperature Sensor	3900030901	1
24	Rear Grill	01473043	1
25	Condenser Assy	01163938	1
26	Clapboard Assy	0123315301	1
27	Coping	01255005P	1
28	Supporting Board(Condenser)	01795010	1
29	Motor Support Sub-Assy	01705036	1
30	Fan Motor	1501506402	1
31	Left Side Plate	01305093P	1
32	Axial Flow Fan	10335008	1
33	handle	26233053	1
34	Connecting Cable	4002050421	0
35	Electric Box Assy	10000201927	1
36	Electric Box	20113027	1
37	Radiator	49010252	1
38	Main Board	30138000731	1

Above data is subject to change without notice.

NO.	Description	Part Code	Qty
		MS-E21AIN	
1	Front grill	22413045	1
2	Front Panel	01535013P	1
3	Chassis Sub-assy	01700000120P	1
4	Drainage Connector	06123401	1
5	Compressor and fittings	0010524501	1
6	Compressor Gasket	76713066	3
7	Gas-liquid Separator Assy	07225017	1
8	Inhalation Tube	03500600586	1
9	Right Side Plate	01303268P	1
10	Valve support assy	0713395501	1
11	Cut off Valve	07130239	1
12	Cut off Valve	071302391	1
13	Valve cover	20123029	1
14	Temperature Sensor	3900007302	1
15	Temperature Sensor	3900007301	1
16	Temperature Sensor	39000073	1
17	Electric expand valve fitting	4300008402	1
18	Electronic Expansion Valve assy	0713395601	1
19	Electric expand valve fitting	4300008401	1
20	Electric expand valve fitting	43000084	1
21	Magnet Coil	4300040045	1
22	4-way Valve Assy	03073380	1
23	Wiring clamp	26115004	1
24	Clapboard assy	01233116	1
25	Temperature Sensor	3900030901	1
26	Rear Grill	01473043	1
27	Condenser Assy	01163875	1
28	Coping	01255005P	1
29	Motor Support Sub-Assy	0170512001	1
30	Condenser support plate	01173415	1
31	Left Side Plate	01305093P	1
32	Handle	26233053	1
33	Electric box (fireproofing)	01413148	1
34	Electric Box Assy	10000201930	1
35	Connecting Cable	400205405	0
36	Fan Motor	1501506402	1
37	Axial Flow Fan	10335008	1

Above data is subject to change without notice.

NO.	Description	Part Code	Qty
		MS-E24AIN	
1	Front Grill	22413026	1
2	Cabinet	01435004P	1
3	Left Handle	26235401	1
4	Front Side Plate	01305086P	1
5	Electrical Heater (Chassis)	7651000411	1
6	Drainage Connector	06123401	1
7	Chassis Sub-assy	02803280P	1
8	Gas-liquid Separator Assy	07225017	1
9	Compressor and Fittings	0010524501	1
10	Electric Heater(Compressor)	7651873215	1
11	Tube Connector Sub-assy	06643008	2
12	4-Way Valve Assy	03073181	1
13	Connection Pipe	05113723	1
14	Magnet Coil	4300040045	1
15	Electronic Expansion Valve assy	0713395301	1
16	Valve Support Assy	0713395401	1
17	Cut off Valve	07130239	1
18	Cut off Valve	071302391	1
19	Right Side Plate	01314100009P	1
20	Valve Cover	26904100012	1
21	Electric Expand Valve Fitting	4300008402	1
22	Electric Expand Valve Fitting	4300008401	1
23	Electric Expand Valve Fitting	43000084	1
24	Temperature Sensor	3900007306	1
25	Temperature Sensor	3900007305	1
26	Temperature Sensor	39000073	1
27	Wiring Clamp	26115004	1
28	Temperature Sensor	3900030901	1
29	Rear Grill	01574100003	1
30	Condenser Assy	01163980	1
31	Electric Box (Fireproofing)	01413426	1
32	Clapboard Sub-Assy	01233190	1
33	Motor Support Sub-Assy	01705025	1
34	Coping	01255006P	1
35	Fan Motor	1501403402	1
36	Condenser Support Plate	01175092	1
37	Axial Flow Fan	10335014	1
38	Left Side Plate	01305043P	1
39	Connecting Cable	4002054026	0
40	Electric Box Assy	10000201933	1
41	Terminal Board	420111041	3
42	Connection Support	01703211	1
43	Electric Box	20113015	1
44	Main Board	30138000732	1
45	Electric Box Cover Sub-Assy	02603217	1

Above data is subject to change without notice.

NO.	Description	Part Code	Qty
		MS-E28AIN	
1	Front Grill	22413048	1
2	Cabinet	01435004P	1
3	Left Handle	26235401	1
4	Front Side Plate	01305086P	1
5	Electrical Heater (Chassis)	7651000411	1
6	Drainage Connector	06123401	1
7	Chassis Sub-assy	02803280P	1
8	Gas-liquid Separator Assy	07225017	1
9	Compressor and Fittings	0010524501	1
10	Electric Heater(Compressor)	7651873215	1
11	Tube Connector Sub-assy	06643008	2
12	4-Way Valve Assy	03073181	1
13	Connection Pipe	05113723	1
14	Magnet Coil	4300040045	1
15	Electronic Expansion Valve assy	07133953	1
16	Valve Support Assy	07133954	1
17	Cut off Valve	07130239	1
18	Cut off Valve	071302391	1
19	Right Side Plate	01314100009P	1
20	Valve Cover	26904100012	1
21	Electric Expand Valve Fitting	4300008403	1
22	Electric Expand Valve Fitting	4300008402	1
23	Electric Expand Valve Fitting	4300008401	1
24	Electric Expand Valve Fitting	43000084	1
25	Temperature Sensor	3900007307	1
26	Temperature Sensor	3900007306	1
27	Temperature Sensor	3900007305	1
28	Temperature Sensor	39000073	1
29	Wiring Clamp	26115004	1
30	Temperature Sensor	3900030901	1
31	Rear Grill	01574100003	1
32	Condenser Assy	01163980	1
33	Electric Box (Fireproofing)	01413426A	1
34	Clapboard Sub-Assy	01233190	1
35	Motor Support Sub-Assy	01705025	1
36	Coping	01255006P	1
37	Fan Motor	1501403402	1
38	Condenser Support Plate	01175092	1
39	Axial Flow Fan	10335014	1
40	Left Side Plate	01305043P	1
41	Connecting Cable	4002054026	0
42	Electric Box Assy	10000201934	1
43	Terminal Board	420111041	4
44	Connection Support	01703211	1
45	Electric Box	20113015	1
46	Main Board	30138000737	1
47	Electric Box Cover Sub-Assy	02603217	1

Above data is subject to change without notice.